



INSTRUCTIONS

J06424

2017-10-23



SOFTAIL EXTENDED REACH CONTROLS KITS

GENERAL

Kit Number

50500839

Models

For model fitment information, see the P&A Retail Catalog or the Parts and Accessories section of www.harley-davidson.com (English only).

Additional Parts

In addition to the parts from the kit, DOT 4 BRAKE FLUID (41800219) is also required for installation.

For accessories and kit part numbers see your local Harley-Davidson dealer, www.harley-davidson.com or your Harley-Davidson Genuine Motor Parts and Accessories catalog.

▲ WARNING

Rider and passenger safety depend upon the correct installation of this kit. Use the appropriate service manual procedures. If the procedure is not within your capabilities or you do not have the correct tools, have a Harley-Davidson dealer perform the installation. Improper installation of this kit could result in death or serious injury. (00333b)

NOTE

This instruction sheet references service manual information. A service manual for your model motorcycle is required for this installation and is available from a Harley-Davidson dealer.

Kit Contents

See Figure 4 and Table 1.

PREPARE THE MOTORCYCLE

1. **For models equipped with saddlebags:** Remove right side saddlebag following instructions in the appropriate service manual.
2. Remove the seat following the directions in the service manual.

▲ WARNING

To prevent accidental vehicle start-up, which could cause death or serious injury, remove main fuse before proceeding. (00251b)

3. Remove main fuse. See service manual.

4. Secure motorcycle in upright position.

NOTE

This kit is not compatible with engine guards.

5. If the engine guard is present, remove and discard it.

LEFT SIDE

Component Removal

1. See Figure 1. Remove the left side foot support bracket, and shifter rod following the instructions in the appropriate service manual.
2. Remove and discard plastic plug for engine guard fastener if present.

Component Installation

1. See Figure 4. Select left hand mounting bracket (3) from the kit.
2. See Figure 1. Install left hand mounting bracket (8) to frame. Tighten mounting screws (6).
Torque: 54–61 N·m (40–45 ft-lbs) *Left-hand mounting bracket screws*
3. Assemble foot support bracket (7) to left hand mounting bracket. Tighten mounting screws (9).
Torque: 54–61 N·m (40–45 ft-lbs) *Left-hand foot support screws*
4. Assemble shifter rod from the kit.
5. Install shifter rod to shifter rod lever (5) at the transmission. Tighten screw (2).
Torque: 13.5–19 N·m (120–170 **in-lbs**) *Shifter rod screw*
6. Install shifter rod to shifter arm (1) with a screw and nut. Tighten.
Torque: 13.5–19 N·m (120–170 **in-lbs**) *Shifter rod screw*
7. Adjust shifter rod ends (3) for rider posture and tighten jam nuts (4).
Torque: 9–13.5 N·m (80–120 **in-lbs**) *Shifter rod jam nuts*



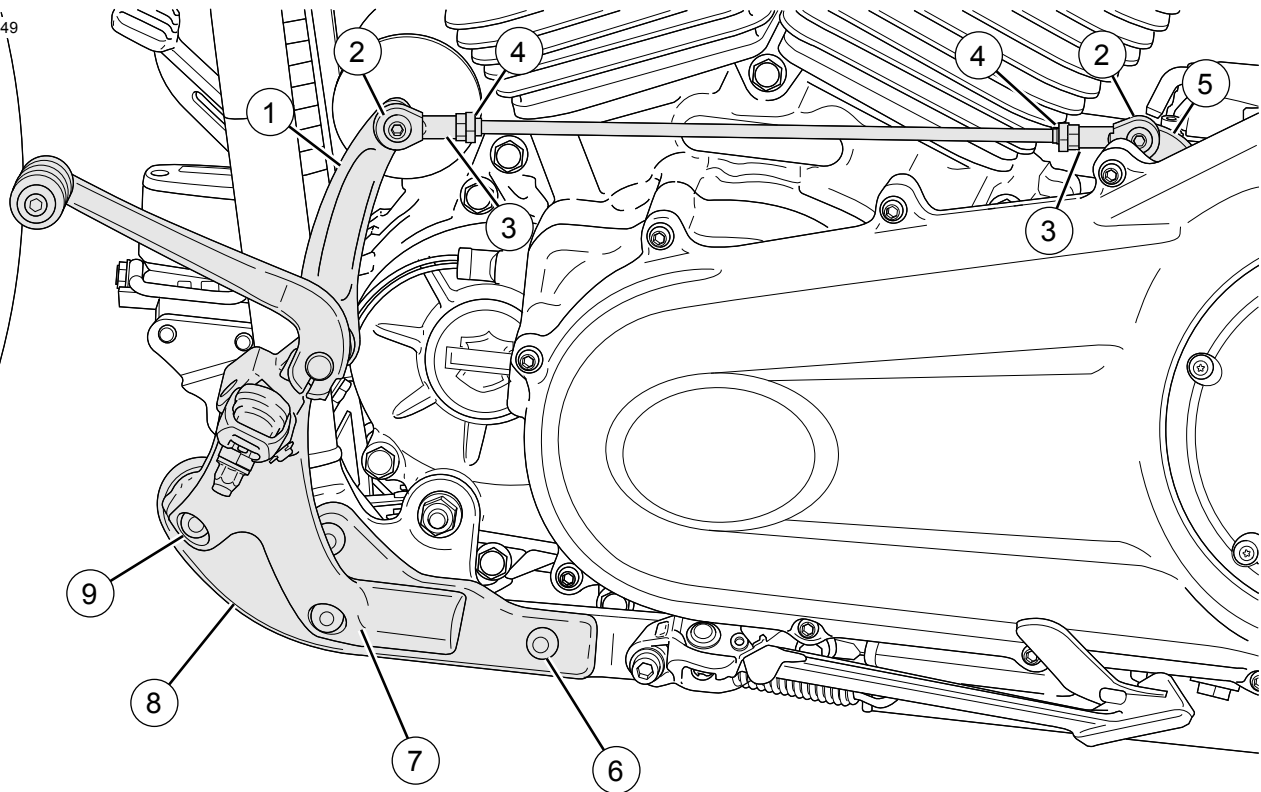

- | | |
|------------------------|---------------------------------------|
| 1. Shifter arm | 6. Bracket screw (2) |
| 2. Screw (2) | 7. Foot support bracket |
| 3. Shifter rod end (2) | 8. Left-hand mounting bracket |
| 4. Jam nut (2) | 9. Foot support screw with washer (2) |
| 5. Shifter rod lever | |

Figure 1. Extended Reach Controls - Left Side

RIGHT SIDE

Removal of Components

1. Remove right side foot control support, rear brake line, rear brake lever, and rear master cylinder following instructions in the appropriate service manual.
2. See Figure 2. Pull wire lead connectors (1) and disconnect stoplamp switch (2).

NOTICE

Remove brake line components carefully. Damage to seating surfaces can cause leakage. (00320a)

⚠ WARNING

Be sure that no lubricants or fluids get on tires, wheels or brakes when changing fluid. Traction can be adversely affected, which could result in loss of control of the motorcycle and death or serious injury. (00047d)

3. Remove rear brake line following the instructions in the appropriate service manual.

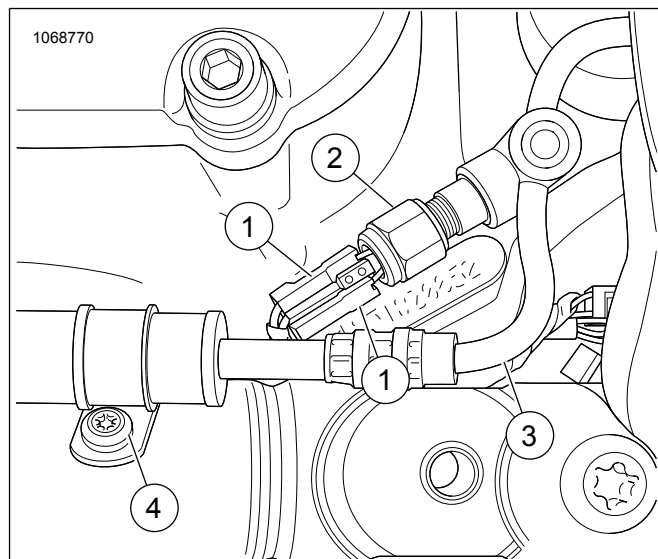

1. Connector (2)
2. Stop lamp switch
3. Rear brake line
4. Rear brake line mounting fastener

Figure 2. Rear Stop Lamp Switch

Installation of Components

1. See Figure 3. Install right hand mounting bracket (4) to frame. Tighten mounting screws (5).
Torque: 54–61 N·m (40–45 ft-lbs) *Mounting bracket screws*
2. Install rear master cylinder (2) to right hand mounting bracket. Tighten mounting screws (7).
Torque: 24–30 N·m (18–22 ft-lbs) *Rear master cylinder mounting screws*
3. Install rear brake lever (1), and foot support bracket (3) following instructions in the appropriate service manual.

4. **NOTE**

Route rear brake line in the original location. Verify that brake line runs parallel to rear of brake lever bracket and

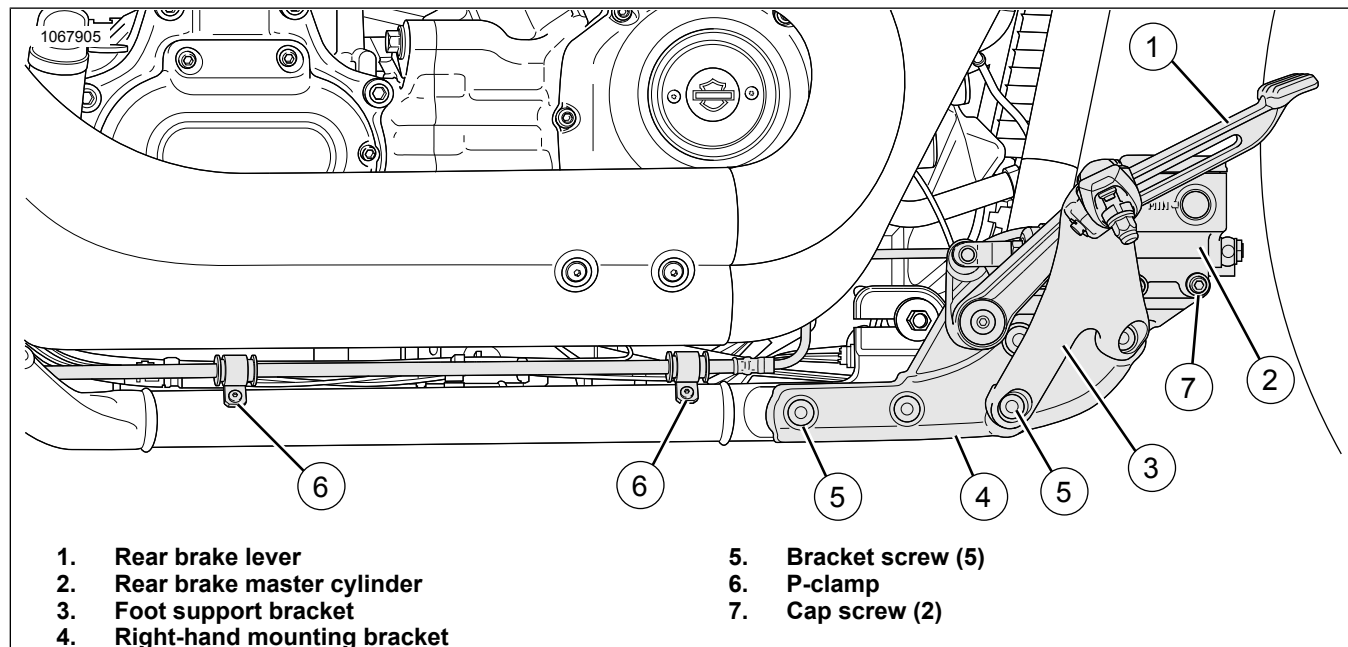

Figure 3. Extended Reach Controls - Right Side

BLEEDING THE REAR BRAKE

⚠ WARNING

Be sure that no lubricants or fluids get on tires, wheels or brakes when changing fluid. Traction can be adversely affected, which could result in loss of control of the motorcycle and death or serious injury. (00047d)

1. Check brake fluid level and refill if necessary following instructions in the service manual.

NOTE

Hydraulic brake fluid bladder-type pressure equipment can be used to fill brake master cylinder through the bleeder valve. Remove the master cylinder reservoir cover so that the system cannot pressurize. Do not use pressure bleeding equipment when the hydraulic system is sealed with master cylinder reservoir cover and gasket in place.

that the brake line does not rub against any part of the bracket.

See Figure 2. Install rear brake line and stoplamp switch following instructions in the appropriate service manual.

⚠ WARNING

Use denatured alcohol to clean brake system components. Do not use mineral-based solvents (such as gasoline or paint thinner), which will deteriorate rubber parts even after assembly. Deterioration of these components can cause brake failure, which could result in death or serious injury. (00291a)

NOTICE

DOT 4 brake fluid will damage painted and body panel surfaces it comes in contact with. Always use caution and protect surfaces from spills whenever brake work is performed. Failure to comply can result in cosmetic damage. (00239c)

⚠ WARNING

Clean reservoir filler cap or cover before removing. Use only DOT 4 brake fluid from a sealed container. Contaminated fluid can adversely affect braking or clutch disengagement, which could result in death or serious injury. (00504d)

▲ WARNING

Contact with DOT 4 brake fluid can have serious health effects. Failure to wear proper skin and eye protection could result in death or serious injury.

- **If inhaled:** Keep calm, remove to fresh air, seek medical attention.
- **If on skin:** Remove contaminated clothing. Rinse skin immediately with plenty of water for 15-20 minutes. If irritation develops, seek medical attention.
- **If in eyes:** Wash affected eyes for at least 15 minutes under running water with eye lids held open. If irritation develops, seek medical attention.
- **If swallowed:** Rinse mouth and then drink plenty of water. Do not induce vomiting. Contact Poison Control. Immediate medical attention required.
- See Safety Data Sheet (SDS) for more details available at sds.harley-davidson.com

(00240e)

2. Bleed brakes following instructions in the appropriate service manual.

RETURN TO SERVICE

1. **For models equipped with saddlebags:** Install right side saddlebag following instructions in the appropriate service manual.
2. Install main fuse. See service manual.
3. Install left side cover. See service manual.
4. Install seat. After installing seat, pull up on seat to verify it is secure. See service manual.
5. With the OFF/RUN switch turned to RUN, actuate the rear brake pedal to verify operation of the brake lamp.

▲ WARNING

After repairing the brake system, test brakes at low speed. If brakes are not operating properly, testing at high speeds can cause loss of control, which could result in death or serious injury. (00289a)

6. Test ride the motorcycle. If the brake feels soft, repeat the rear brake bleeding procedure.

Service Parts

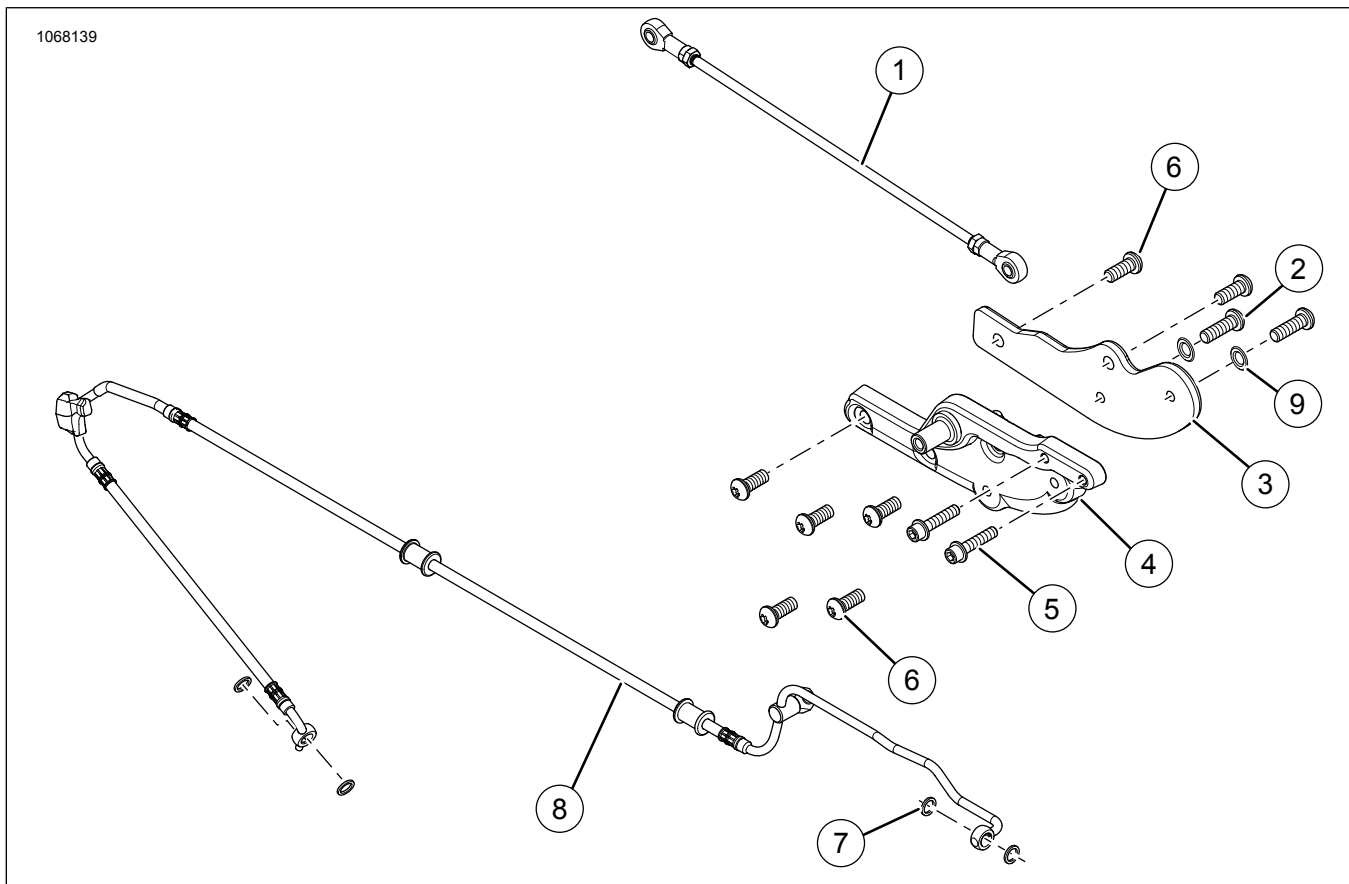

Figure 4. Service Parts: Extended Reach Controls Kit

Table 1. Service Parts

Item	Description (Quantity)	Part Number
1	Shift rod	33600170
2	Cap screw, button head, 3/8-16 X 1.25 inch (2)	4044
3	Left hand mounting bracket	Not Sold Separately
4	Right hand mounting bracket	Not Sold Separately
5	Cap screw, socket head (2)	10500022
6	Cap screw, button head, 3/8-16 X 1 inch (7)	4512A
7	Brake line gasket (4)	41751-06A
8	Extended rear brake line, non ABS	Not Sold Separately
9	Washer (2)	6874