



# INSTRUCTIONS

J03241

2022-09-23



## QUICK RELEASE DETACHABLE WINDSHIELD KIT

### GENERAL

#### Kit Number

Table 1. Kits

Kits	Models
59802-05	Standard height, clear
58751-05	Standard height, smoke
57199-05	Compact low profile, smoke
58360-09	Standard height, clear, black braces
58376-09	Compact, low profile, smoke, black braces

### Models

For model fitment information, see the P&A Retail Catalog or the Parts and Accessories section of [www.harley-davidson.com](http://www.harley-davidson.com) (English only).

#### ⚠ WARNING

Rider and passenger safety depend upon the correct installation of this kit. Use the appropriate service manual procedures. If the procedure is not within your capabilities or you do not have the correct tools, have a Harley-Davidson dealer perform the installation. Improper installation of this kit could result in death or serious injury. (00333b)

### Kit Contents

See Figure 6 and Table 2.

### INSTALLATION

#### Prepare Motorcycle - All Models Except FXSTB

##### NOTE

Cover the front fender and the front of the fuel tank with clean shop towels to prevent scratching. Damage to the finish could result.

1. Relocate clutch cable to the inside of the handlebars as follows:
2. See Figure 1. Slide rubber boot off cable adjuster. Adjuster is located approximately halfway along clutch cable by the front frame downtube.
3. Holding cable adjuster with 1/2 inch wrench, loosen jam nut using a 9/16 inch wrench. Back jam nut away from cable adjuster. Move adjuster toward jam nut to introduce a large amount of free play at the hand lever.

4. Remove small snap ring from pivot pin groove at bottom of clutch lever bracket. Remove pivot pin and clutch hand lever from bracket. Remove anchor pin and clutch cable eyelet from clutch hand lever.
5. See Figure 2. Reroute clutch cable to the inside of the handlebars and reconnect clutch cable to clutch lever.
6. See Figure 3. Turn cable adjuster away from jam nut until slack is eliminated at hand lever. Pull clutch cable ferrule away from clutch lever bracket to check free play. Turn cable adjuster as necessary to obtain 1/16 to 1/8 inch (1.6-3.2 mm) free play between end of cable ferrule and clutch lever bracket.
7. Hold adjuster with 1/2 inch wrench. Using 9/16 inch wrench, tighten jam nut against cable adjuster. Cover cable adjuster mechanism with rubber boot.

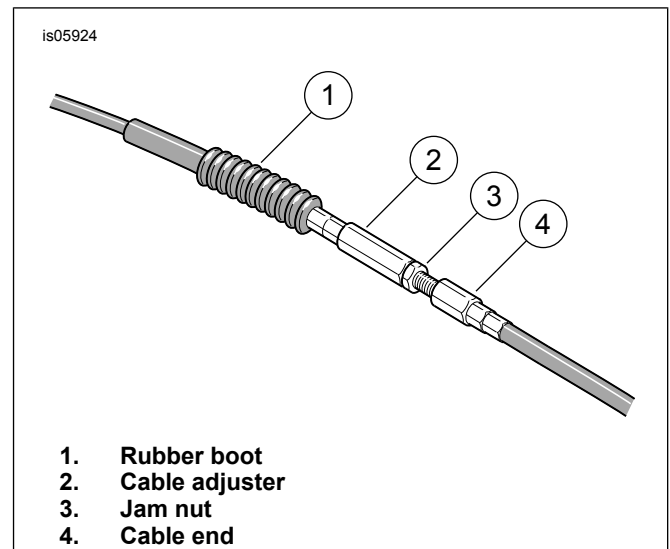
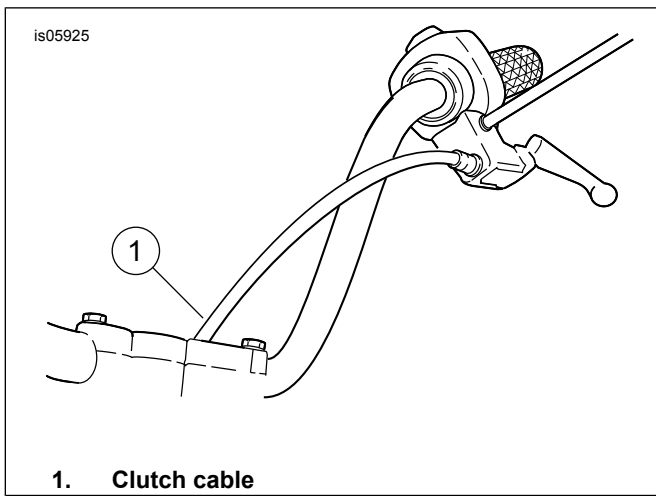

Figure 1. Clutch Cable Adjuster





1. Clutch cable  
Figure 2. New Clutch Cable Routing

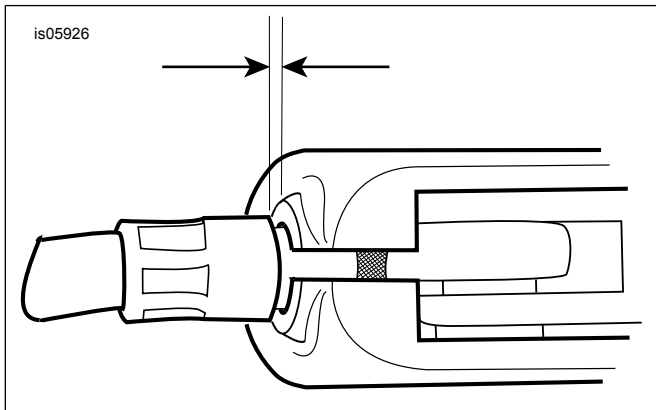

Figure 3. 1/16 - 1/8 inch (1.6 - 3.2 mm) Clutch Cable Free Play

8. If necessary, reposition the clutch cable mount ties attached to the frame downtube to best allow the clutch cable to move naturally when the handlebars turn fully from left to right fork locks. Cycle the hand lever several times to confirm.

**▲ WARNING**

After relocating clutch cable, check that clutch hand lever opens and closes smoothly when handlebars are turned fully left or right. Slow clutch lever response could result in loss of control and death or serious injury (00424d)

**▲ WARNING**

Be sure that steering is smooth and free without interference. Interference with steering could result in loss of vehicle control and death or serious injury. (00371a)

9. See Figure 6 and Table 2. Relocate the turn signals according to the instructions included in the Turn Signal Relocation Kit (23).

### Install the Windshield - All Models

1. See Figure 4. Remove the windshield sub-assembly from the packaging and place face down on a clean, soft surface with the mount brackets facing upward.

2. See Figure 6 and Table 2. Remove both the clamp and hardware kits from the packaging, and separate similar parts in preparation for assembly. Note that the lower clamps are exactly alike, and the left and right upper clamps can be identified by extensions that point upwards.
3. See Figure 5. Assemble the clamp assemblies and hardware stacks.

**▲ WARNING**

The cupped side of the Belleville (cone) washers must face each other and sandwich the windshield mount brackets at each mount point. Failure to orient washers correctly can reduce windshield's ability to break away in a collision, which could result in death or serious injury. (00422b)

4. One clamp at a time, with the clamp facing upward and inboard of the windshield bracket (2), tighten the shoulder bolts (1) enough to hold the clamp orientation to the windshield during mounting of the windshield to the motorcycle. The bolts will be fully tightened later.

*NOTE*

Keep front wheel straight to prevent brackets from scratching fuel tank.

5. Make sure all four clamps are in the open position, then bring the windshield (with the clamp side away from you) to the front of the motorcycle.

*NOTE*

The polycarbonate windshield is fairly flexible and can be bent to spread the clamps away from the headlamp to ease installation to the motorcycle. Take care not to scratch the headlamp housing with the clamps while positioning the windshield to the fork sliders.

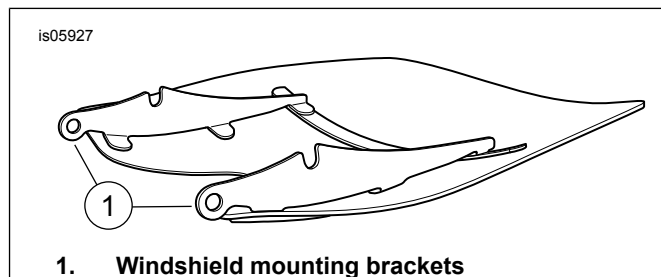

1. Windshield mounting brackets  
Figure 4. Windshield Mounting Brackets

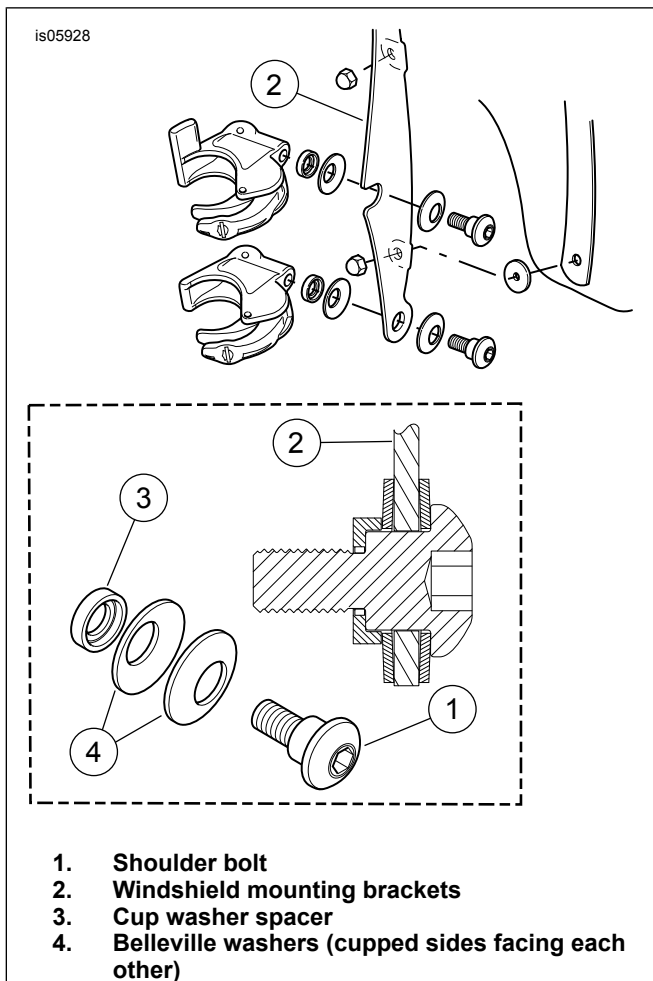

**Figure 5. Windshield Mounting Clamp**

6. Straddle the front fender. Center the windshield around the headlamp and seat the clamps onto the fork sliders.
7. Starting at the bottom (either side) and with the shoulder bolts just a little more than finger tight, close each clamp, taking note that the clamps self-align to the fork sliders and to each other.

**NOTICE**

**Do not exceed recommended torque when installing mounting screws. Damage to windshield can result. (00385a)**

8. With the windshield clamps now clamped to the fork sliders, make sure that the shoulder portion of the shoulder bolts are fully seated in each windshield bracket location. Torque.  
Torque: 6.7 N·m (60 in-lbs)
9. Turn the handlebars fully to the left and right fork stops to confirm that the throttle cables move freely.

### Removing the Windshield - All Models

1. To remove the windshield, open the four clamps in any sequence. Take care to not scratch the headlamp housing or fuel tank as noted during installation.
2. When storing the windshield, place in a location where the windshield clamps will receive the greatest protection. Keep from locations where the windshield may be impacted or dropped. Do not stack anything on top of the assembly.
3. Prior to re-installation after any storage period, inspect the clamps and hardware for fastener preload and cleanliness. Each clamp should have a pair of rubber gaskets in the clamp saddle that mates to the fork slider, and should cycle open and closed freely.

### Care and Cleaning

**NOTICE**

**Polycarbonate windshields/wind deflectors require proper attention and care to maintain. Failure to maintain polycarbonate properly can result in damage to the windshield/wind deflector. (00483e)**

- Do not use benzene, paint thinner, gasoline or any other type of harsh cleaner on the windscreen/windshield. Doing so will damage the surface.
- Do not clean polycarbonate in hot sun or high temperature.
- Powdered, abrasive or alkaline cleanser will damage the windscreen/windshield..
- Sunlight reflections off of the inside curvature of a windscreen/windshield can, at certain times of the day, cause extreme heat build-up on motorcycle instruments. Exercise care in parking. Park facing the sun, place an opaque object over the instruments, or adjust the windscreen/windshield to avoid reflections.
- Do not use benzene, paint thinner, gasoline or any other cleaning agents on the rubber bushings. Doing so will damage the bushing surfaces.

*NOTE*

*Covering the windshield with a clean, wet cloth for about 15 minutes before washing will make dried bug removal easier.*

# SERVICE PARTS

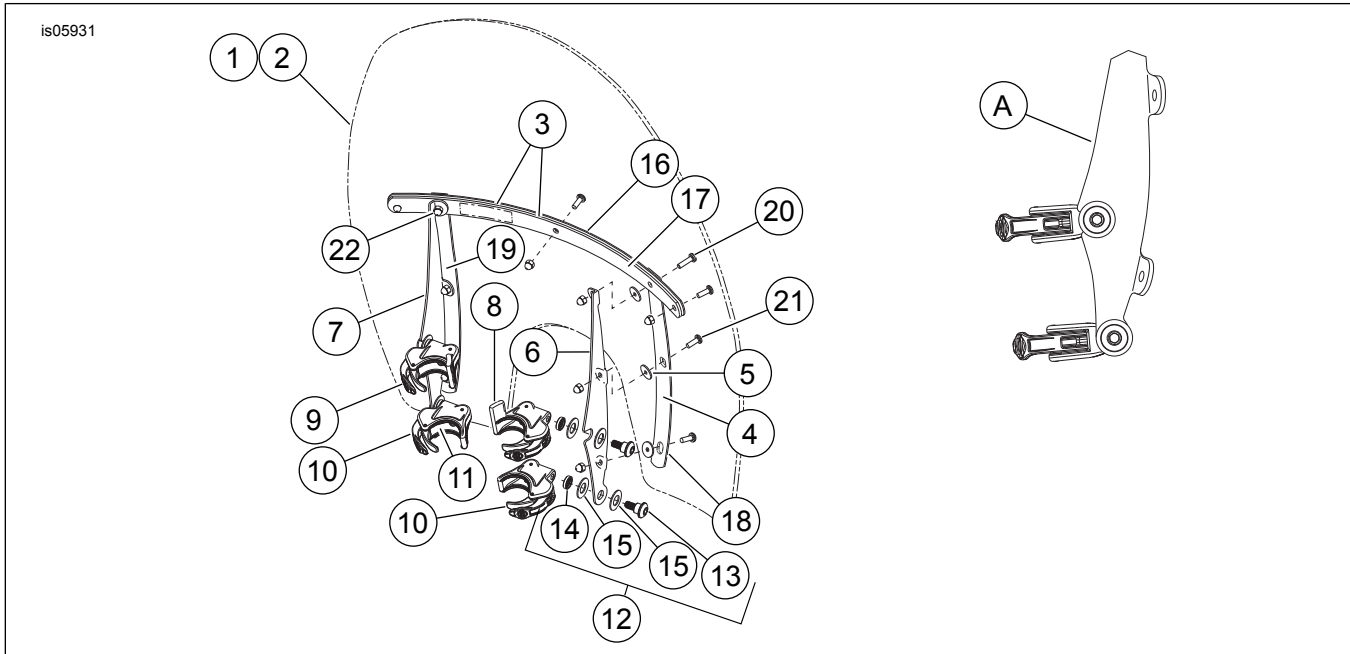

**Figure 6. Service Parts: Quick Release Detachable Windshield Kits**

**Table 2. Service Parts: Quick Release Detachable Windshield Kits**

Item	Description (Quantity)	Part Number	Item	Description (Quantity)	Part Number
1	Windshield service kit (includes items 2-5) for Kits 59802-05 & 58360-09 for Kit 58751-05 for Kits 57199-05 & 58376-09	58750-05 58777-05 57201-05	12	Hardware kit, windshield mount (4) (includes items 13 through 15)	58790-04
2	Windshield (included in item 1)		13	Shoulder screw, button head	Not Sold Separately
3	Tape, horizontal (2)	58052-78	14	Spacer, cup washer	Not Sold Separately
4	Tape, vertical	59804-05	15	Belleville washer (2)	Not Sold Separately
5	Washer, rubber, black	58152-96	16	Brace, horizontal, outer Brace, horizontal, outer, black	58051-78A 58069-09
6	Bracket, windshield mount, right Bracket, windshield mount, right, black	59855-05 58399-09	17	Brace, horizontal, inner Brace, horizontal, inner, black	58050-78A 58068-09
7	Bracket, windshield mount, left Bracket, windshield mount, left, black	59844-05 58398-09	18	Brace, vertical, right Brace, vertical, right, black	59809-05 58616-09
8	Clamp assembly, right upper (includes two of item 11)	59868-05	19	Brace, vertical, left Brace, vertical, left, black	59808-05 58388-09
9	Clamp assembly, left upper (includes two of item 11)	59859-05	20	Screw, button head, TORX®, lock patch, 12-24 x 13/16 inch (2)	2452
10	Clamp assembly (2) (includes two of item 11)	58740-05	21	Screw, button head TORX, lock patch, 12-24 x 5/8 inch (7)	2921A
11	Gasket (8) (two per clamp)	58791-04	22	Acorn nut, 12-24 (chrome) (9)	7651
			23	Turn signal relocation kit (not shown)	58742-05
			A	Side view of clamps assembled to bracket.	
			NOTE: Appearance of actual components may vary from illustration.		