



INSTRUCTIONS

J05288

2017-08-22



DETACHABLE WINDSHIELD KIT

GENERAL

Kit Number

57400053

Models

For model fitment information, see the P&A Retail Catalog or the Parts and Accessories section of www.harley-davidson.com (English only).

NOTE

See the P&A Retail Catalog or the Parts and Accessories section of www.harley-davidson.com (English only) for a collection of matching Genuine Motor Accessory items that are available. These can be easily installed at the same time as this kit.

Additional Parts Required

DOCKING HARDWARE KIT 58164-96A

On models equipped with passing lamps, the turn signals may be relocated under the passing lamps using **Turn Signal Relocation Kit 68603-01**, available separately from any Harley-Davidson dealer. Refer to the Instruction Sheet provided with that kit for relocation procedures, then go to "Windshield Installation" in this Instruction Sheet.

▲ WARNING

Rider and passenger safety depend upon the correct installation of this kit. Use the appropriate service manual procedures. If the procedure is not within your capabilities or you do not have the correct tools, have a Harley-Davidson dealer perform the installation. Improper installation of this kit could result in death or serious injury. (00333b)

NOTE

This instruction sheet references Service Manual information. A Service Manual for your model motorcycle is required for this installation and is available from a Harley-Davidson Dealer.

Kit Contents

See the Service Parts Illustration and Table for your kit.

INSTALLATION

Windshield Installation

NOTE

Place shop rags on the headlamp, front fender and front of the fuel tank to prevent scratches to these components. Be sure the windshield assembly does not contact chrome or painted parts. Contact will cause scratches to chrome or painted parts.

1. Install the four mounting clamps to the front forks but do not tighten.
2. Attach windshield to clamps by rotating the bushings onto the windshield brackets one at a time.
3. See Figure 1. Use the wireform (1) from the Docking Hardware Kit to secure the throttle cables to the upper mounting clamp as shown. Place the chrome washer (2) from the kit between the wireform and the mounting clamp nut.
4. See the Docking Hardware Service Parts illustration. Assemble the hardware for the upper windshield mounting as shown. Leave the clamp nuts loose so the clamps can be slid up and down the fork tubes to allow for proper adjustment.
5. Hook the two lower windshield assembly jaws into the grooves of the lower bushings, then slide the upper clamp assemblies into place until the upper bushings fit firmly into the upper windshield jaws.

▲ WARNING

Improper installation of accessories or loading of cargo can affect motorcycle stability and handling, which could result in death or serious injury. (00455b)

▲ WARNING

Failure to provide adequate clearance between stationary and moving parts can cause loss of control, which could result in death or serious injury. (00378a)

6. With the windshield in place, tighten the clamp nuts to 10 ft-lbs (14 Nm). Be sure the clamp does not rotate during tightening (the mounting bushing must be parallel to the windshield brackets).

NOTE

Inspect the windshield for proper adjustment in relation to the headlamp opening. If necessary, adjust the mounting clamps up or down for proper headlamp to windshield relationship.

NOTE

Check mounting hardware periodically. Never ride with loose mounts. A loose mounting causes extra stress on all other mounts, as well as the windshield itself, and could result in premature failure of components.



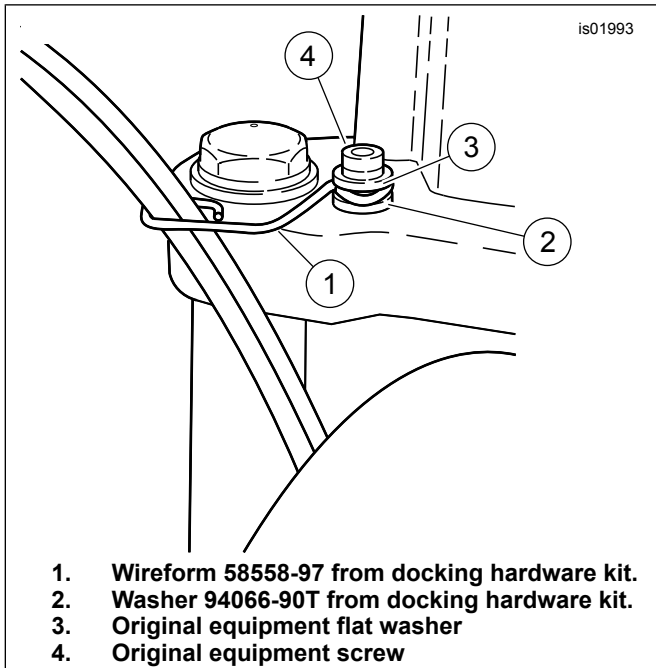

Figure 1. Throttle Cable Attachment

Care and Cleaning

NOTE

Sunlight reflections off of the inside curvature of a windshield can, at certain times of the day, cause extreme heat build-up on motorcycle instruments. Exercise care in parking. Park facing the sun, place an opaque object over the instruments, or adjust the windshield to avoid reflections.

NOTICE

Polycarbonate windshields/wind deflectors require proper attention and care to maintain. Failure to maintain polycarbonate properly can result in damage to the windshield/wind deflector. (00483e)

NOTE

Do not clean polycarbonate windshield in hot sun or high temperature. Powdered, abrasive or alkaline cleanser will damage the windshield. Never scrape the windshield with a razor blade or other sharp instruments because permanent damage will result.

NOTICE

Use only Harley-Davidson recommended products on Harley-Davidson windshields. Do not use harsh chemicals or rain sheeting products, which can cause windshield surface damage, such as dulling or hazing. (00231c)

- Do not use benzine, paint thinner, gasoline, lubricants (including Armorall®), or other cleaning agents on the rubber bushings. They will damage the bushing surfaces.

NOTE

Covering the windshield with a clean, wet cloth for about 15 minutes before washing will make dried bug removal easier.

⚠ WARNING

Before starting engine, be sure throttle control will snap back to idle position when released. A throttle control that prevents engine from automatically returning to idle can lead to loss of control, which could result in death or serious injury. (00390a)

⚠ WARNING

Be sure that steering is smooth and free without interference. Interference with steering could result in loss of vehicle control and death or serious injury. (00371a)

SERVICE PARTS

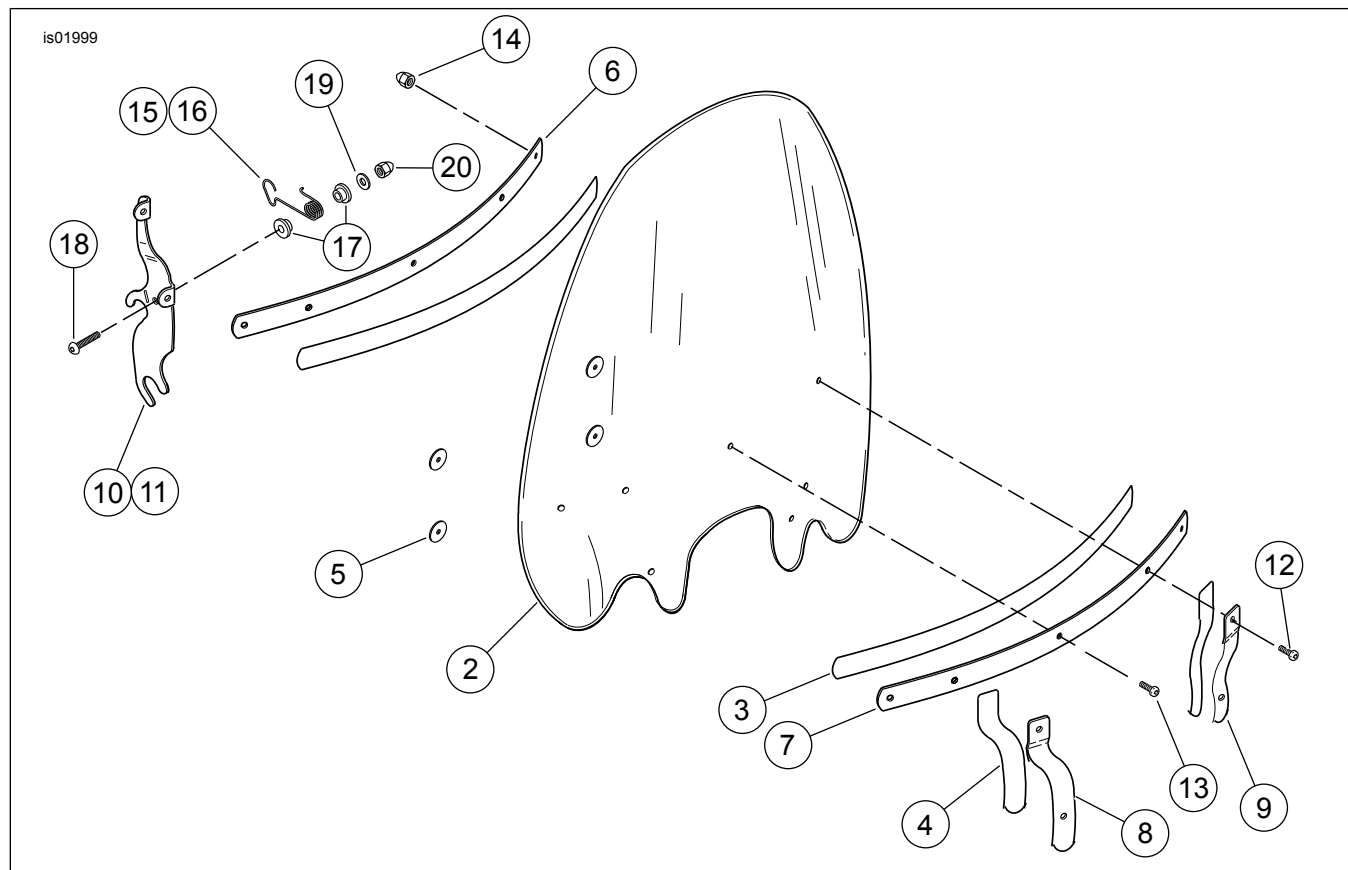

Figure 2. Service Parts: Windshield Kit

Table 1. Service Parts Table

Item	Description (Quantity)	Part Number	Item	Description (Quantity)	Part Number
Kit 57400053					
1	Windshield service kit (includes items 2 through 5)	57400054	11	Brace, windshield (left)	12700018
2	Windshield	Not Sold Separately	12	Screw, pan head, Torx (2) #12-24 x 13/16 in. long	2452
3	Tape, horizontal (2)	58052-78	13	Screw, pan head, Torx (5) #12-24 x 5/8 in. long	2921A
4	Tape, vertical (2)	57714-01	14	Acorn nut, #12-24 (chrome) (7)	7651A
5	Washer, black rubber (4)	58152-96	15	Windshield retainer, wireform (right)	58580-96A
6	Brace, windshield horizontal (inner)	58050-78A	16	Windshield retainer, wireform (left)	58579-96A
7	Brace, windshield horizontal (outer)	58051-78A	17	Bushing, Nylon (4)	58272-95
8	Brace, windshield outer (right)	57712-01	18	Screw, button head (chrome) (2)	94426-95
9	Brace, windshield outer (left)	57713-01	19	Flat washer, 1/4 in. (silver) (2)	6703
10	Brace, windshield (right)	12700017	20	Acorn nut, 1/4-20 (chrome) (2)	94004-90T