



INSTRUCTIONS

J06307

2022-02-23



SCREAMIN' EAGLE MILWAUKEE-EIGHT STAGE 2 KIT

GENERAL

Kit Number

92500047, 92500058, 92500074, 92500075

Models

For model fitment information, see the P&A Retail Catalog or the Parts and Accessories section of www.harley-davidson.com (English only).

Ensure you are using the most current version of the instruction sheet which is available at: www.harley-davidson.com/isheets

Installation Requirements

These items are available at a Harley-Davidson dealership.

- **2017-2019:** Separate purchase of Oil Pump Assembly kit (Part No. 62400247-Oil Cooled) or (Part No. 62400248-Twin Cooled) is required.
- Separate purchase of Cam Drive Retention kit (Part No. 25566-06).
- Separate purchase of Screamin Eagle High Flow Air Cleaner kit.
- Separate purchase of Cam Spacer Kit (Part No. 25928-06) is recommended. This kit contains five different spacers to achieve proper sprocket alignment.

See Harley-Davidson Genuine Motor Parts and Accessories catalog or Screamin Eagle Pro catalog for available kits.

See appropriate sections in service manual for the special tools required to install this kit.

Proper installation of this kit also requires ECM recalibration, contact a Harley-Davidson dealer.

⚠ WARNING

Rider and passenger safety depend upon the correct installation of this kit. Use the appropriate service manual procedures. If the procedure is not within your capabilities or you do not have the correct tools, have a Harley-Davidson dealer perform the installation. Improper installation of this kit could result in death or serious injury. (00333b)

NOTE

This instruction sheet references service manual information. A service manual for your model vehicle is required for this installation and is available from a Harley-Davidson dealer.

EO Label

This product information label is required in the state of California only. **PRODUCT INFORMATION LABEL IS**

REQUIRED TO PASS THE CALIFORNIA SMOG CHECK PROGRAM.

1. Place information label on right down tube of frame directly below Vehicle Identification Number (VIN) label.
2. **Do Not** install this product label over other product information labels.
3. This product information label **must not be installed** on other vehicles than specified.

Reference Table 1 for EO number.

Table 1. California EO Label

Description	EO Label Part Number
Label, Environmental Protection Agency (EPA), EO	14002143A

Kit Contents

See Figure 3 to Figure 4, and Table 2 to Table 3.

NOTE

Engine-related performance parts are intended FOR THE EXPERIENCED RIDER ONLY.

REMOVAL

Prepare for Service

1. Raise the vehicle.

NOTE

See owner's manual and disarm security system.

⚠ WARNING

When servicing the fuel system, do not smoke or allow open flame or sparks in the vicinity. Gasoline is extremely flammable and highly explosive, which could result in death or serious injury. (00330a)

2. Remove main fuse. Refer to the service manual.

Remove Engine Components

1. Remove existing air cleaner assembly. Refer to AIR CLEANER REMOVAL in service manual.
2. Remove existing exhaust system. Refer to EXHAUST SYSTEM REMOVAL in service manual.

NOTE

When removing the stock pushrods, do not cut pushrods using a method that creates metal debris (such as using a hacksaw)



or die grinder). Metal debris in the engine causes severe damage.

3. Remove stock pushrods using a bolt cutter.
4. Remove cam cover.
5. Remove front and rear cylinder spark plugs from left side of vehicle.
6. With the vehicle on a lift, raise the rear wheel off ground.
7. With the vehicle in 5th gear, rotate rear wheel to rotate engine and align camshaft/crankshaft timing marks.
8. Using CRANKSHAFT/CAMSHAFT SPROCKET LOCKING TOOL (PART NUMBER: HD-47941) lock camshaft and crankshaft. Refer to ENGINE in service manual.
9. Remove cam components and camshaft. Refer to ENGINE in service manual.
10. Remove and inspect the oil pump. Refer to ENGINE in service manual.

NOTE

It is recommended to install Oil Pump Cover with Seal (6) if it is not present.

INSTALLATION

Install Engine Components

1. See Figure 4. Install oil pump. Refer to ENGINE in service manual.
2. Inspect camshaft components and replace if necessary. Refer to ENGINE in service manual.
3. Install camshaft and cam components. Refer to ENGINE in service manual.
4. Verify camshaft to crankshaft timing marks are properly aligned.
5. With transmission in gear use rear wheel to turn engine over until both front cylinder tappets are at their lowest point.
6. See Figure 1. Loosen locknut on all of the pushrods and adjust them to their shortest length.

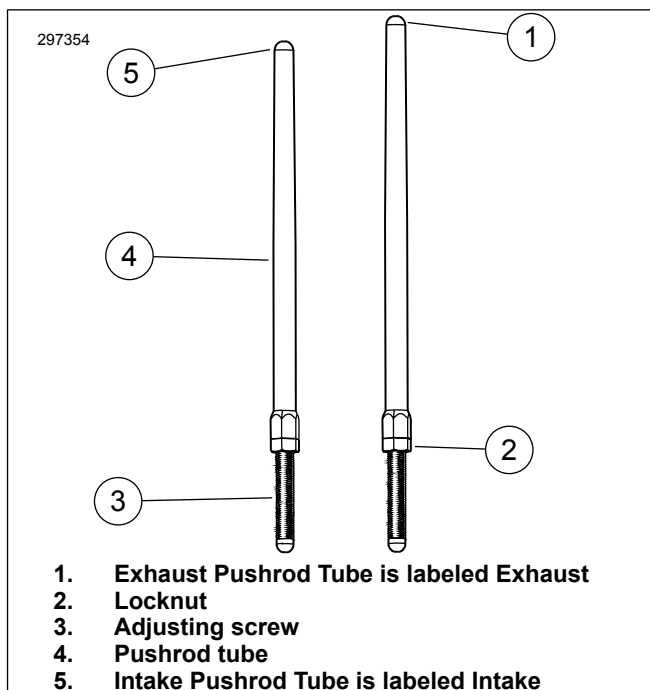

Figure 1. Adjustable Pushrod

7. See Figure 2. Install the intake pushrods into the pushrod covers. Replace O-rings, lower pushrod cover and spring cover keeper with new components supplied in kit. Be sure adjuster end of pushrod is down.

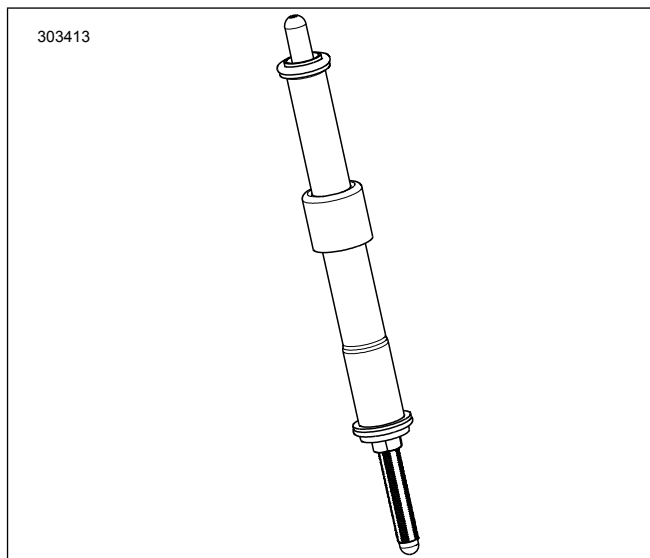

Figure 2. Pushrod Installed into Pushrod Cover

8. Insert the pushrod (within the pushrod tube) into the front cylinder head intake pushrod hole (hole closest to the cylinder) then slip the adjuster end of the pushrod into the tappet block.

NOTE

Pushrod adjustment must be made with engine cold.

9. Adjust pushrods.
 - a. Adjust pushrod length to zero clearance by hand.

- b. With the pushrod adjusting screw kept from rotating with a 5/16 in. wrench, slowly turn the pushrod tube with a 1/2 in. wrench, 2-1/2 complete turns clockwise (lengthening the pushrod) as viewed from the bottom. (There is a dot on the flats of the pushrod tube that can be used as a reference.)
- c. Hold adjusting screw and tighten locknut with 1/2 in. open end wrench against the pushrod tube. If pushrod turns with locknut use three open end wrenches, one to hold the pushrod tube, one to hold adjusting screw and one to turn locknut.
- d. Repeat steps 5 through step C for the exhaust pushrod.

NOTE

Wait ten minutes before turning engine over after adjusting front or rear cylinder pushrods. This wait allows tappets to bleed down and prevents bending pushrods or valves. Pushrods should turn freely and valves must be on their seats (closed) before turning over engine.

- e. Wait ten minutes. With transmission in gear, use rear wheel to turn engine over until both rear cylinder tappets are at their lowest position.
- f. Repeat steps 5 through step D for the rear cylinder.
- g. Install pushrod spring cap retainers on pushrod covers. Install spark plugs and return transmission to neutral.

10. Install camshaft cover.
11. Install exhaust system. Refer to EXHAUST SYSTEM INSTALLATION in service manual.
12. Install air cleaner assembly. Refer to instruction sheet included with separately purchased SE high flow air cleaner kit.

Final Assembly

1. Verify that the vehicle is in neutral.
2. Run engine. Repeat several times to verify proper operation.
3. Recalibrate ECM with proper calibration for configuration. See Dealer for details.

NOTICE

You must recalibrate the ECM when installing this kit. Failure to properly recalibrate the ECM can result in severe engine damage. (00399b)

4. Run engine. Repeat several times to verify proper operation.

Operation

Refer to BREAK-IN RIDING RULES in the owner's manual for instructions to break in the vehicle.

SERVICE PARTS

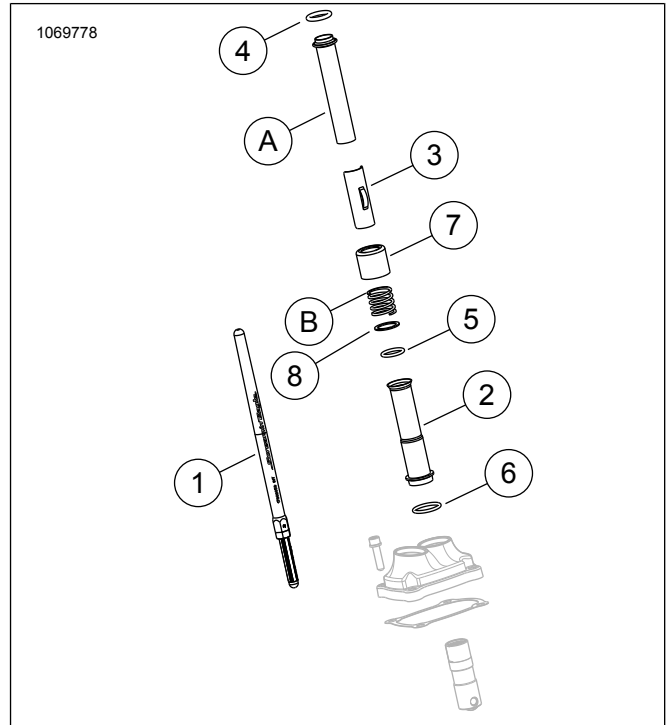

Figure 3. Service Parts

Table 2. Service Parts Table

Item	Description (Quantity)	Part Number
1	Pushrod assembly (Intake) (2)	Not Sold Separately
1	Pushrod assembly (Exhaust) (2)	Not Sold Separately
2	Pushrod cover, lower, chrome (4) Pushrod cover, lower, gloss black (4)	17938-83 Not Sold Separately
3	Keeper, pushrod spring cover, chrome (4) Keeper, pushrod spring cover, gloss black (4)	Not Sold Separately
4	O-ring, pushrod cover, upper (4)	11293
5	O-ring, pushrod cover, lower (4)	11145A
6	O-ring, pushrod cover, middle (4)	11132A
7	Pushrod tube collar, chrome (4) Pushrod tube collar, gloss black (set of 4)	17945-36B 17900076
8	Washer (2)	6762D
OE items and above item 7 Pushrod tube collar, chrome (ONLY) reused during final assembly		
A	Upper pushrod cover (2)	
B	Cover spring (2)	

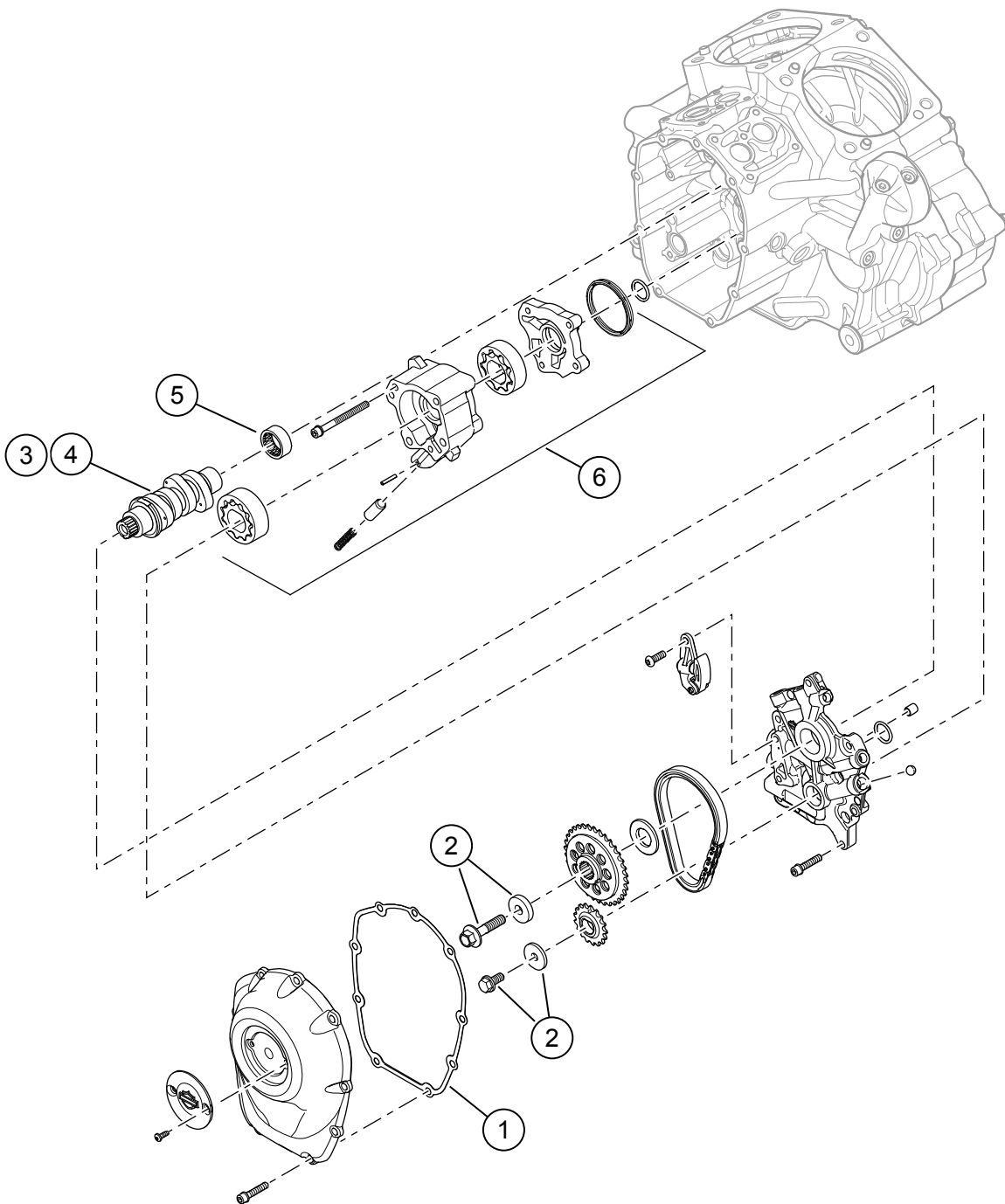

Figure 4. Service Parts: Screamin' Eagle Milwaukee-eight Stage 2 Kit

Table 3. Service Parts: Screamin' Eagle Milwaukee-eight Stage 2 Kit

Item	Description (Quantity)	Part Number
1	Gasket, cam cover	25700370
2	Camshaft drive sprocket retention kit	25566-06
3	Camshaft, SE8-447 (in Stage 2 Kit 92500047, chrome / 92500074, gloss black)	25400199
4	Camshaft, SE8-462 (in Stage 2 Kit 92500058, chrome / 92500075, gloss black)	25400200
5	Bearing, needle (1) (must be purchased separately, if needed)	9215
6	Oil pump assembly (must be purchased separately, if needed)	62400247 or 62400248