



# INSTRUCTIONS

J06666

2018-08-20



## TOMAHAWK REAR WHEELS

### GENERAL

#### ▲ WARNING

Install only wheels and installation kits approved for your model motorcycle. Contact a Harley-Davidson dealer to verify fitment. Mismatching wheels and installation kits or installing wheels not approved for your model can cause loss of control, which could result in death or serious injury. (00610c)

### Kit Number

40900623 and 40900624

### Models

For model fitment information, see the P&A Retail Catalog or the Parts and Accessories section of [www.harley-davidson.com](http://www.harley-davidson.com) (English only).

### Kit Contents

These kits include the custom wheel only.

See Figure 1 and Table 1.

### Installation Requirements

Proper installation of this kit requires the separate purchase of tire 44006-09.

Proper installation of these kits require the separate purchase of the following parts which are available at a Harley-Davidson dealer.

- Wheel Installation Kit (See Table 2 and Table 3 to determine required installation kit.)
- 5 stock Brake Disk Screws (43567-92) or a Chrome Screw Kit (46647-05) which includes 5 screws.
- Wheel Bearing Remover and Installer (94134-09A)

#### ▲ WARNING

Rider and passenger safety depend upon the correct installation of this kit. Use the appropriate service manual procedures. If the procedure is not within your capabilities or you do not have the correct tools, have a Harley-Davidson dealer perform the installation. Improper installation of this kit could result in death or serious injury. (00333b)

#### NOTE

This instruction sheet references service manual information. A service manual for your model motorcycle is required for this installation and is available from a Harley-Davidson dealer.

### Recommended Products

The following Harley-Davidson Genuine Motor Accessories are recommended for proper maintenance and cleaning:

- Chrome Clean & Shine (93600031 (US) / 93600082 (International))
- Glaze Poly Sealant (93600026 (US) / 93600079 (International))
- Harley® Wheel and Spoke Brush (43078-99)
- Wheel & Tire Cleaner (93600024 (US) / 93600076 (International))

### INSTALLATION

1. Remove existing rear wheel assembly. Save axle, axle nut, brake disc and wheel spacers for kit installation. Refer to the service manual.

#### NOTE

Prior to removing or installing the wheel, the rear brake caliper must be removed.

The cotter pin or spring clip for the axle nut must be replaced. They are available for purchase from a dealer. See a dealer for the correct part number.

#### NOTE

Install short valve stem (43157-83A) included in the installation kit. Discard all other valve stems.

2. See Figure 1. Install valve stem assembly (H) on wheel. Refer to the service manual.

#### NOTICE

**Do not re-use brake disc/rotor screws. Re-using these screws can result in torque loss and damage to brake components. (00319c)**

3. Assemble wheel installation kit components, stock brake disc and sprocket to wheel using the appropriate service parts table. Refer to the service manual.

#### NOTE

Install the primary bearing first using appropriate service manual and WHEEL BEARING REMOVER/INSTALLER.

The brake side of the wheel is the primary side.

The bearing shims provided in the installation kits are not required for these kits and can be discarded.

4. Install rear wheel (1), stock axle and stock spacers to motorcycle. Refer to REAR WHEEL in service manual.



## MAINTENANCE AND CLEANING

Chrome parts must be maintained regularly to keep their original shine and luster.

1. Clean heavily-soiled wheel surfaces using Harley-Davidson Wheel and Tire Cleaner, applied with Harley Wheel and Spoke Brush.
2. Thoroughly clean chrome with a good quality chrome cleaner, such as Harley Bright Chrome Cleaner.
3. After cleaning and polishing, seal the finish with a good quality sealer, such as Harley Glaze Polish and Sealant.

## SERVICE PARTS

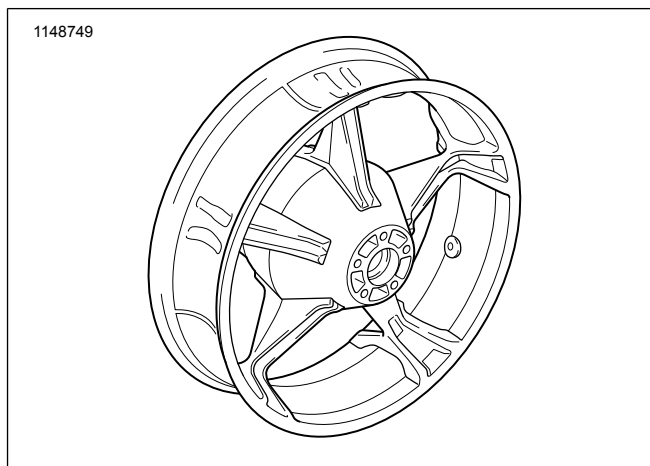

Figure 1. Service Parts: Aggressor Rear Wheels

Table 1. Service Parts and Wheel Kit Contents

Kit	Item	Description (Quantity)	Part Number
40900623 and 40900624	1	Wheel	Not Sold Separately

Table 2. REAR 25mm Bearing Wheel Installation Kit (41456-08C)

REAR 25 MM Bearing Wheel Installation Kit (41456-08C)		ITEM (Quantity Used and Description)				
Fitment	Wheel Size	A	C	H	I	J
2014 and later Touring without ABS	18 x 5.0 in	2	1	*	*	0
Installation kits are designed to work with many different wheel styles and A Bearing, regular (2) 9276A fitments. Contact a Harley-Davidson dealer to verify that the wheel and installation kits are both designed and approved for the motorcycle they are being installed on. NOTES: *See NOTE above valve installation step in INSTALLATION to determine which valve stem to use for your particular kit. Discard other valve stem(s). **See INSTALLATION to determine if shim is required.		A	Bearing, regular (2)		9276A	
		C	Axle sleeve		41349-07	
		H	Valve stem, short		43157-83A	
		I	Valve stem, long		43206-01	
		J	Valve stem, pull thru		40999-87	

Table 3. REAR 25 MM Bearing ABS Wheel Installation Kit (41453-08C)

REAR 25 MM Bearing ABS Wheel Installation Kit (41453-08C)		ITEM (Quantity Used and Description)					
Fitment	Wheel Size	A	B	C	H	I	J
2014 and later Touring with ABS	18 x 5.0 in	1	1	1	*	*	0
Installation kits are designed to work with many different wheel A Bearing, regular 9276A styles and fitments. Contact a Harley-Davidson dealer to verify that the wheel and installation kits are both designed and approved for the motorcycle they are being installed on. NOTES: *See NOTE above valve installation step in INSTALLATION to determine which valve stem to use for your particular kit. Discard other valve stem(s). **Primary bearing. Bearing must be installed with red side facing the wheel.		A	Bearing, regular		9276A		
		B	Bearing, ABS**		9252		
		C	Axle sleeve		41349-07		
		H	Valve stem, short		43157-83A		
		I	Valve stem, long		43206-01		
		J	Valve stem, pull thru		40999-87		