



INSTRUCTIONS

J06567

2018-08-21



MILWAUKEE-EIGHT DOMINION ROCKER BOX COVER KIT

GENERAL

Kit Number

25700779, 25700780

Models

For model fitment information, see the P&A Retail Catalog or the Parts and Accessories section of www.harley-davidson.com (English only).

Installation Requirements

Proper installation of this kit requires the separate purchase of two gaskets (Part No. 25700372), four O-rings (Part No. 11900090), and the use of LOCTITE 243 MEDIUM STRENGTH THREADLOCKER AND SEALANT (BLUE) (99642-97).

⚠ WARNING

Rider and passenger safety depend upon the correct installation of this kit. Use the appropriate service manual procedures. If the procedure is not within your capabilities or you do not have the correct tools, have a Harley-Davidson dealer perform the installation. Improper installation of this kit could result in death or serious injury. (00333b)

NOTE

This instruction sheet references service manual information. A service manual for your model motorcycle is required for this installation and is available from a Harley-Davidson dealer.

Kit Contents

See Figure 2, Figure 3 and Table 1

PREPARE

NOTE

The following directions assume the engine is installed into the frame. If the engine is removed, greater access to the covers can be obtained and some of the techniques outlined below may not be applicable.

NOTE

See service manual for information about the following procedures:

1. Remove seat.
2. Remove fuel tank.
3. Remove upper cooling lines.
4. Disconnect sensors.

INSTALLATION

1. Remove Original Equipment (OE) rocker box cover following instructions in the service manual.

2. Install new rocker cover gasket (A) and rocker cover (1).

3. **NOTE**

See service manual to chase and clean threads of bolts.

Apply threadlocker and install the bolts.

Consumable: LOCTITE 243 MEDIUM STRENGTH THREADLOCKER AND SEALANT (BLUE) (99642-97)

4. **NOTE**

Hold hex of center stud with an open end wrench while tightening center bolt.

Follow the torque sequence shown in Figure 1 and secure bolts. Tighten.

Torque: 13.6–15.8 N·m (120–140 in-lbs)

5. Repeat procedure for other cylinder head.

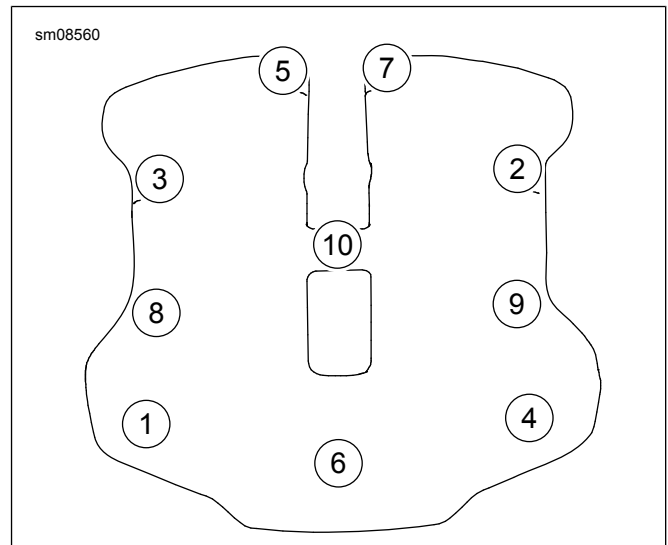

Figure 1.

Complete

NOTE

See service manual for information about the following procedures:

1. Connect sensors.



2. See Figure 3. Install upper cooling lines with **new** O-rings (C).
3. Install fuel tank.
4. Install seat.

INSERT INSTALLATION (Optional)

1. Remove screws (2) from insert pockets and retain.
2. Clean surface for adhesive.
3. Remove adhesive liner.
4. Place on rocker cover (1)
5. Install insert (B) with screws (2). Tighten.
Torque: 2.03 N·m (18 in-lbs)

SERVICE PARTS

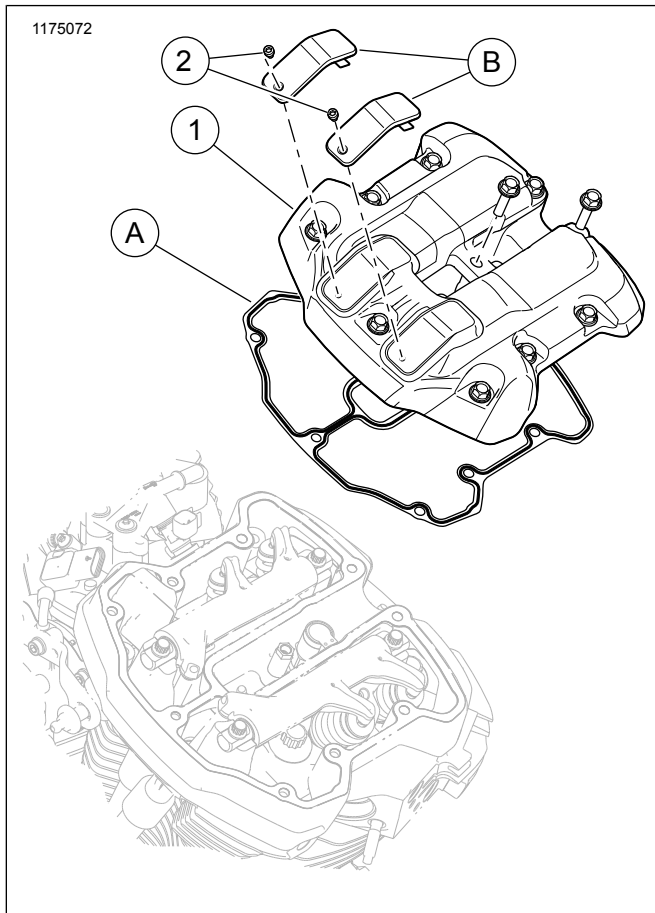

Figure 2. Service Parts: Rocker Box Cover Kit

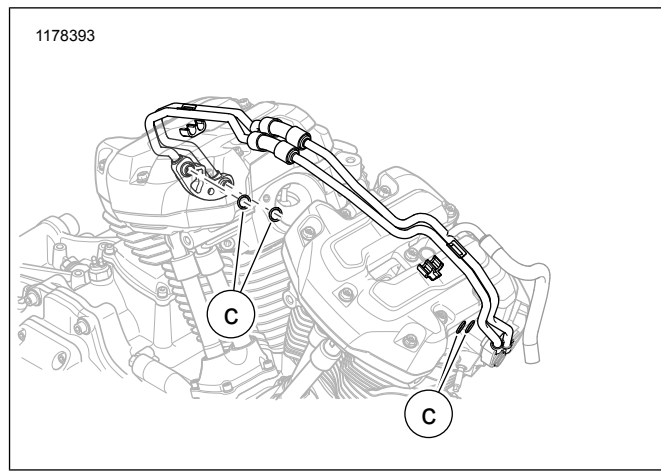

Figure 3. Service Parts: O-ring Location

Table 1. Service Parts

Item	Description (Quantity)	Part Number
1	Rocker cover (2)	Not sold separately
2	Screw (4)	10200611
Service Parts Required Sold Separately		
A	Gasket (2)	25700372
B	Inserts (optional) (4)	
	Black	25700791
	Bronze	25700792
	Orange	25700793
C	O-ring (4)	11900090