



INSTRUCTIONS

J05540

2018-07-27



AIR CLEANER COVER

GENERAL

Kit Number

61300120, 61300128

Models

For model fitment information, see the P&A retail catalog or the Parts and Accessories section of www.harley-davidson.com (English only).

Additional Parts Required

NOTE

Screamin' Eagle Air Cleaner Assemblies can be purchased separately or as a component part of a Screamin' Eagle Stage Kit. Contact your Harley-Davidson dealer for information.

Kit Contents

See Figure 1 and Table 1.

SERVICE PARTS

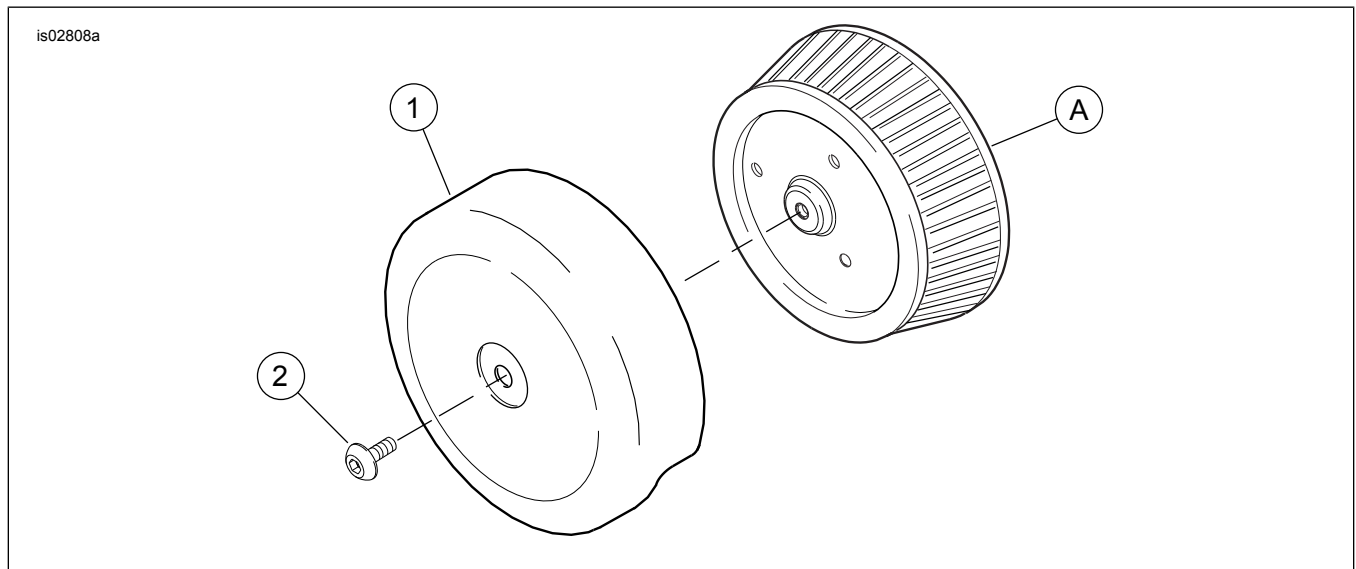

Figure 1. Service Parts: Air Cleaner Cover

Table 1. Service Parts Table

Item	Description (Quantity)	Part Number
1	Air Cleaner Cover	Not sold separately
2	Screw	94599-98
Items mentioned in text but not included in kit:		
A	Air filter	

INSTALLATION

1. Remove air cleaner cover screw and air cleaner cover.

NOTE

Before installing screw (2), apply LOCTITE 243 MEDIUM STRENGTH THREADLOCKER AND SEALANT (BLUE) (99642-97) to screw threads.

2. Install new air cleaner cover (1) (with cutout facing down). Use screw (2) to secure cover in place. Tighten.

Torque: 4–7 N·m (3–5 ft-lbs)

3. If removing the Original Equipment (OE) intake you must apply the provided Warning Label in a clearly visible area. We suggest attaching the sticker to the following:

- a. **Softail:** Right side lower fender
- b. **Dyna:** Right side swing arm.
- c. **Touring/Trike:** Inner primary topside or side cover.

