



INSTRUCTIONS

J05803

2019-08-21



ILLUMINATED HAND CONTROL SWITCH KITS

GENERAL

Kit Numbers

71500248C, 71500250B, 71500561

Models

For model fitment information, see the P&A retail catalog or the Parts and Accessories section of www.harley-davidson.com (English only).

These hand controls are a direct replacement for the original equipment (OE) hand controls, and install the same way.

Installation Requirements

⚠ WARNING

Rider and passenger safety depend upon the correct installation of this kit. Use the appropriate service manual procedures. If the procedure is not within your capabilities or you do not have the correct tools, have a Harley-Davidson dealer perform the installation. Improper installation of this kit could result in death or serious injury. (00333b)

NOTE

This instruction sheet refers to service manual information. A service manual for this year/model motorcycle is required for this installation. One is available from a Harley-Davidson dealer.

ELECTRICAL OVERLOAD

NOTICE

It is possible to overload the vehicle's charging system by adding too many electrical accessories. If the combined electrical accessories operating at any one time consume more electrical current than the vehicle's charging system can produce, the electrical consumption can discharge the battery and cause damage to the vehicle's electrical system. (00211d)

⚠ WARNING

When installing any electrical accessory, be certain not to exceed the maximum amperage rating of the fuse or circuit breaker protecting the affected circuit being modified. Exceeding the maximum amperage can lead to electrical failures, which could result in death or serious injury. (00310a)

This kit requires up to 14 mA more current from the electrical system.

Kit Contents

See Figure 2 and Table 1.

PREPARATION

Thoroughly review the entire HAND CONTROL MODULES section of the service manual before installing this kit.

⚠ WARNING

To prevent accidental vehicle start-up, which could cause death or serious injury, remove main fuse before proceeding. (00251b)

NOTE

- **WITH security siren:** With security fob present, turn ignition switch ON. See the service manual. Disarm security system. Turn ignition switch OFF. **IMMEDIATELY** remove the main fuse.
- **WITHOUT security siren:** See the service manual. Remove main fuse.

INSTALLATION

NOTE

- Refer to the service manual for specific information on the following generalized steps.
- Record wire harness paths inside switch packs before removal.

1. Remove one hand control module.
 - a. Remove two screws and the handlebar clamp.
 - b. Remove hand control lever assembly.
 - c. **For CLUTCH side only:** Gently pry up trigger finger switch cap with a small, flat blade screwdriver. Slide cap left to remove.
 - d. **For EITHER side:** Loosen switch housing captive screws. Remove switch housing.
 - e. See Figure 1. Pull up on ratchet retainer (1). Rotate switch pack segments (2, 3) apart.

NOTE

Connector latches are fragile. Use care.



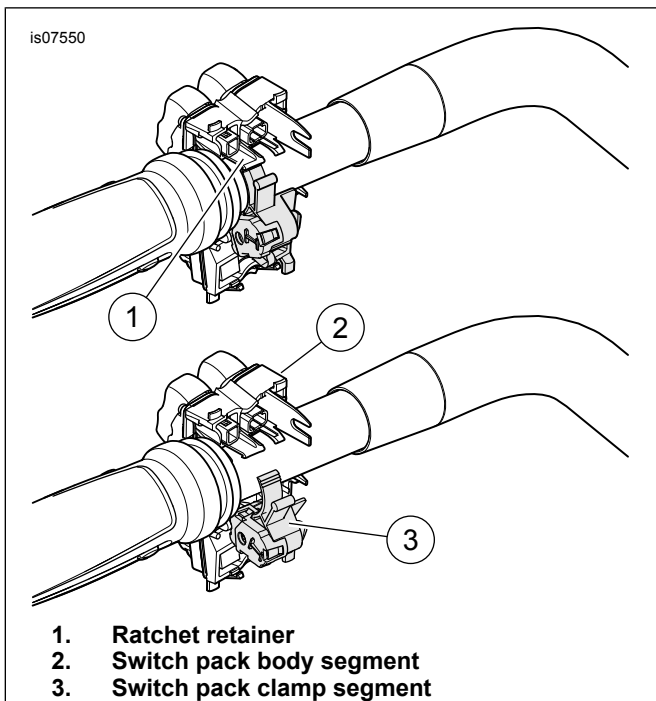

Figure 1. Remove Hand Control Switch Pack

2. Unplug switch pack wire connectors. Discard the switch pack.
3. See Figure 2. Get the correct **new** switch pack (1-4, 18-19) from the kit.

NOTE

Kit 71500248C (left, with audio controls): Two switch caps are provided loose in this kit.

- **Two-wheel models** use cap (11) with "horn" icon.
- **FLHTCUTG models** use cap (12) with "R" and "horn" icons.

Kit 71500561 (right side): Two switch caps are provided loose in this kit.

- **Trike models** use cap (20) with hazard, start, and reverse icons.
- **Models without radio** use cap (7) with 'Information' and right arrow icons.

Install the correct cap to the switch pack per service manual instructions.

4. **ALL models:** Install switch pack per the service manual. Verify that harness is correctly routed to avoid damage. Close the switch pack segments around the handlebar until hearing two definite "clicks". Verify that the shield (Figure 2, Item A or B) is in correct position.

NOTE

Refer to the service manual for specific information on the following generalized steps.

5. Install the hand control lever assembly.
 - a. Install switch housing. Tighten switch housing captive screws until snug.

- b. Install hand control lever assembly.
 - c. Install handlebar clamp with two screws removed earlier, but do not tighten. Position hand control lever assembly and switch housing for rider comfort. Tighten hand control clamp screws to 8.1–12.2 N·m (72–108 in-lbs).
 - d. Tighten switch housing screws to 4–5 N·m (35–45 in-lbs).
 - e. **For brake side only:** Verify free hand grip rotation and slight inboard-outboard free play. **For clutch side only:** Slide trigger finger switch cap right to install.
6. Repeat for the remaining hand control module.

COMPLETION

NOTE

Verify that ignition switch is **OFF** before installing main fuse.

1. See the service manual. Install main fuse.
2. Turn ignition switch ON. Verify that hand control module switches are illuminated.
3. Test switches for proper operation.
4. Turn ignition switch OFF. Verify that hand control module switches are not illuminated.

⚠ WARNING

The left hand control switch pack controls the clutch interlock. A motorcycle with the wrong switch pack installed can start in gear causing loss of control, which could result in death or serious injury. Verify clutch interlock function whenever switch pack is replaced. (00632b)

5. Verify clutch interlock function. Perform the following steps in order. **Do not skip any steps. If any test fails, stop and diagnose the condition before proceeding.**
 - a. Remove spark plug cables from spark plugs.
 - b. Straddle vehicle. Press and hold the rear brake pedal.
 - c. Turn ignition switch ON. Turn the run/stop switch to RUN.
 - d. Shift into neutral and release the clutch lever. Briefly push the start switch. The starter operates.
 - e. Shift into the highest gear. Pull in the clutch lever and briefly press the start switch. The starter operates.
 - f. With the clutch lever released and transmission in gear, briefly press the start switch. The starter does not operate.
 - g. Turn off the ignition and run/stop switches.
 - h. Install spark plug cables.

SERVICE PARTS

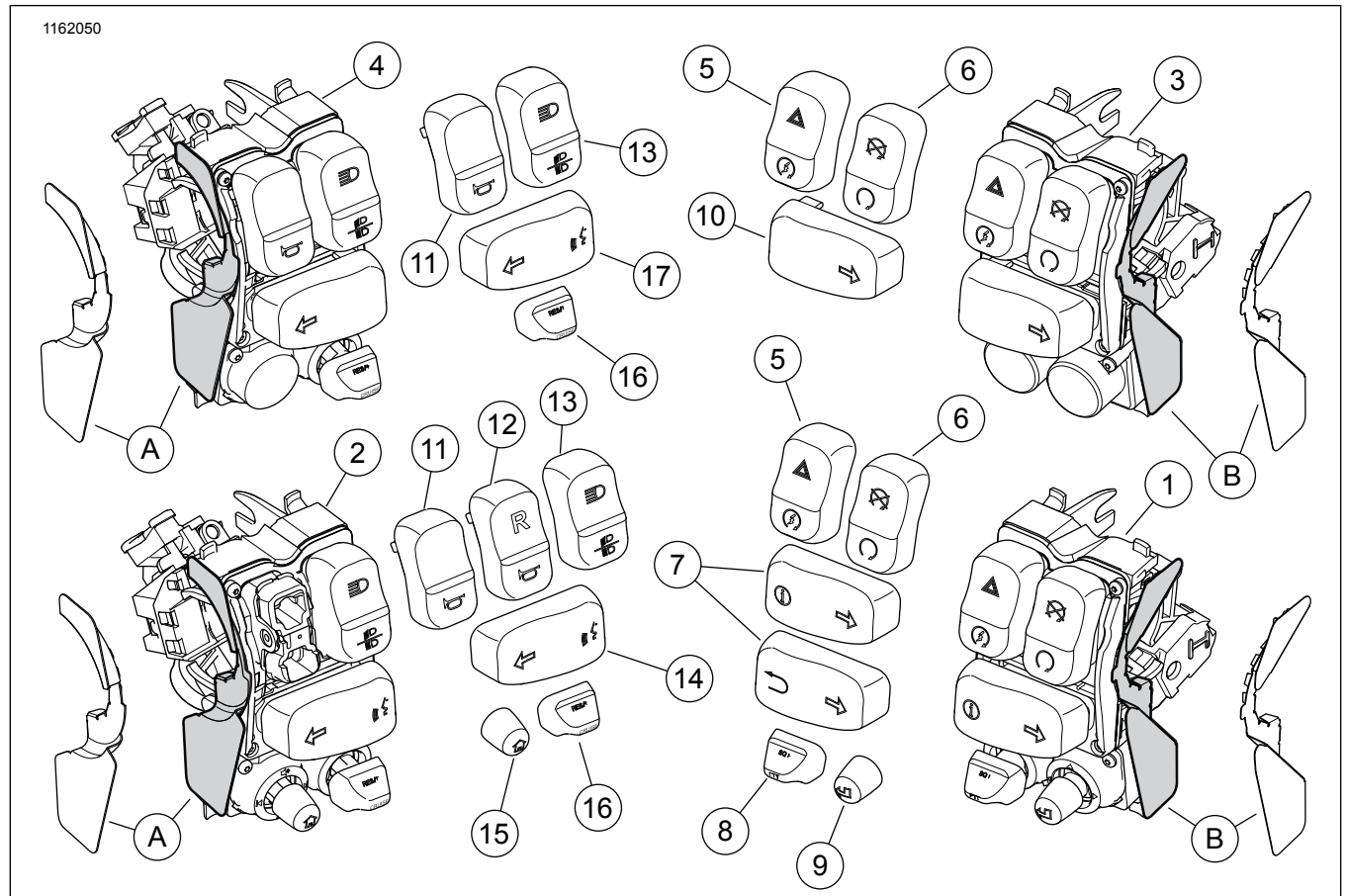

Figure 2. Service Parts, Illuminated Hand Control Switch Kits (without traction control)

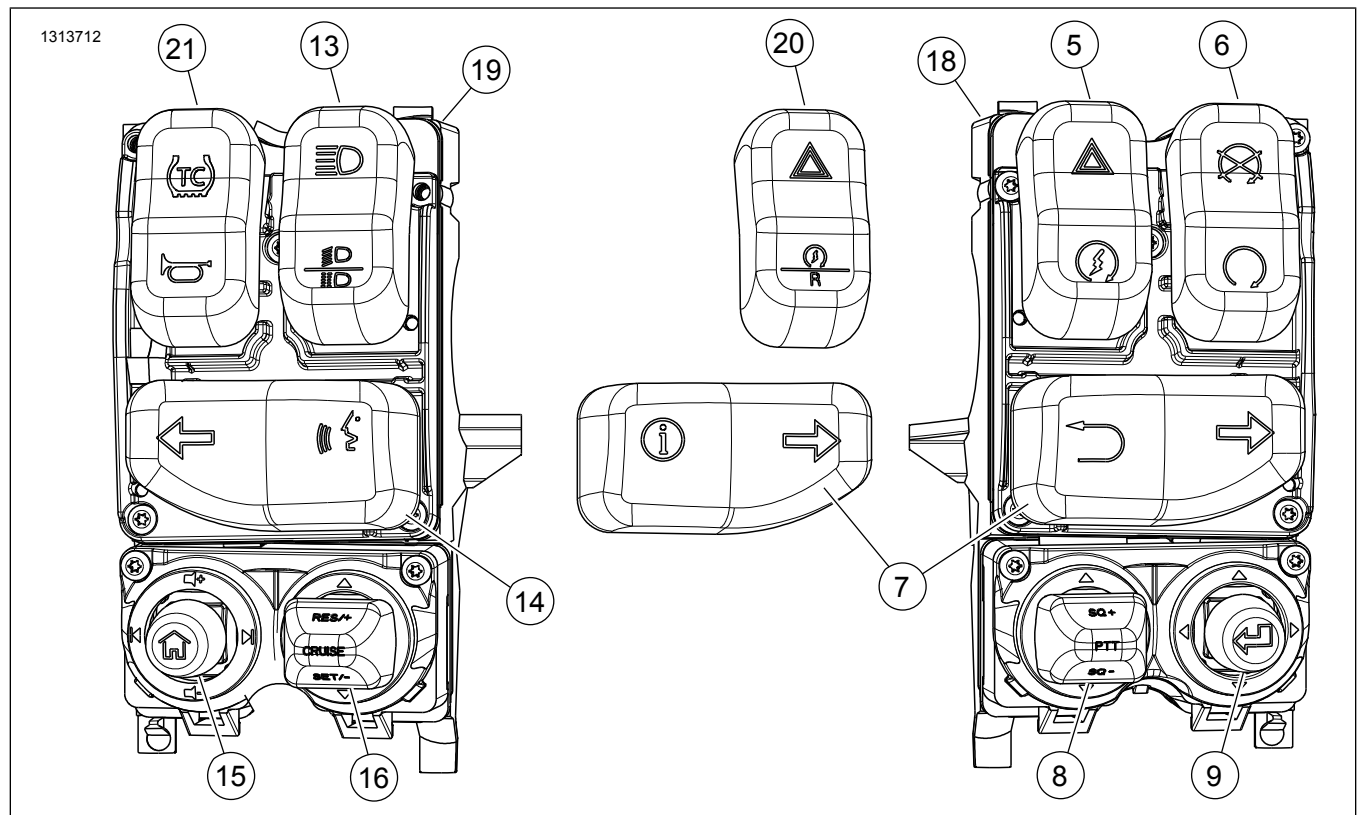

Figure 3. Service Parts, Illuminated Hand Control Switch Kits (with traction control)

SERVICE PARTS

Table 1. Service Parts

Kit	Item	Description (Quantity)	Part Number	
Kit 71500248C, for models WITH audio controls	1	Switch pack, right side, black, with white icons (includes Items 5-9)	71500083	
	2	Switch pack, left side, black, with white icons (includes Items 11-16)	71500084	
	5	• Key cap, vertical, black, with white "start" and "hazard" icons	71500168	
	6	• Key cap, vertical, black, with white "run" and "stop" icons	71500169	
	7	• Key cap, horizontal, black, with white "right turn" and information "i" icons	71500170	
		• Key cap, horizontal, black, with white "right turn" and "back" icons	71500484	
	8	• Key cap, three-way, CB, black, with white "PTT", "SQ+", "SQ-" labels	71500225	
	9	• Button cap, five-way (joystick), black, with white "selection arrow" icon	71500227	
	11	• Key cap, vertical, black, with white "horn" icon (except Trike)	71500165	
	12	• Key cap, vertical, black, with white "R" and "horn" icons (Trike)	71500426	
	13	• Key cap, vertical, black, with white headlamp "high", "low", "flash to pass" icons	71500166	
	14	• Key cap, horizontal, black, with white "left turn" and "voice recognition" icons	71500167	
	15	• Button cap, five-way (joystick), black, with white "home" icon	71500226	
	16	• Key cap, three-way, black, with white "CRUISE", "RES/+", "SET/-" labels	71500224	
	Kit 71500250B, for models WITHOUT audio controls	3	Switch pack, right side, black, with white icons (includes Items 5, 6, 10)	71500163
		4	Switch pack, left side, black, with white icons (includes Items 11, 13, 16, 17)	71500249
5		• Key cap, vertical, black, with white "start" and "hazard" icons	71500168	
6		• Key cap, vertical, black, with white "run" and "stop" icons	71500169	
10		• Key cap, horizontal, black, with white "right turn" icon	71500176	
11		• Key cap, vertical, black, with white "horn" icon	71500165	
13		• Key cap, vertical, black, with white headlamp "high", "low", "flash to pass" icons	71500166	
16		• Key cap, three-way, black, with white "CRUISE", "RES/+" and "SET/-" labels	71500224	
Kit 71500561, for models WITH traction control	5	• Key cap, vertical, black, with white "start" and "hazard" icons	71500168	
	6	• Key cap, vertical, black, with white "run" and "stop" icons	71500169	
	7	• Key cap, horizontal, black, with white "right turn" and information "i" icons	71500170	
		• Key cap, horizontal, black, with white "right turn" and "back" icons	71500484	
	8	• Key cap, three-way, CB, black, with white "PTT", "SQ+", "SQ-" labels	71500225	
	9	• Button cap, five-way (joystick), black, with white "selection arrow" icon	71500227	
	13	• Key cap, vertical, black, with white headlamp "high", "low", "flash to pass" icons	71500166	
	14	• Key cap, horizontal, black, with white "left turn" and "voice recognition" icons	71500167	
	15	• Button cap, five-way (joystick), black, with white "home" icon	71500226	
	16	• Key cap, three-way, black, with white "CRUISE", "RES/+" and "SET/-" labels	71500224	
	18	Switch pack, right side, black, with white icons (includes Items 5-9, 20)	71500485	
	19	Switch pack, left side, black, with white icons (includes Items 13-16, 21)	71500529	
20	• Key cap, vertical, black, with white "hazard" and "start/reverse" icons (Trike)	71500553		
21	• Key cap, vertical, black, with white "Traction Control" and "horn" icons	71500533		
Items mentioned in text:				
	A	Shield, left. (Comes assembled to switch pack. Also shown exploded away for identification.)	Not sold separately	
	B	Shield, right. (Comes assembled to switch pack. Also shown exploded away for identification.)	Not sold separately	