



INSTRUCTIONS

J06765

2019-08-21



TALL RISER KITS

Table 1.

Kits	Suggested Tools	Skill Level ⁽¹⁾	Time
55800852, 55800854	Safety Glasses, Torque Wrench		3 hours

(1) Tightening to torque value or other moderate tools and techniques required

KIT CONTENTS

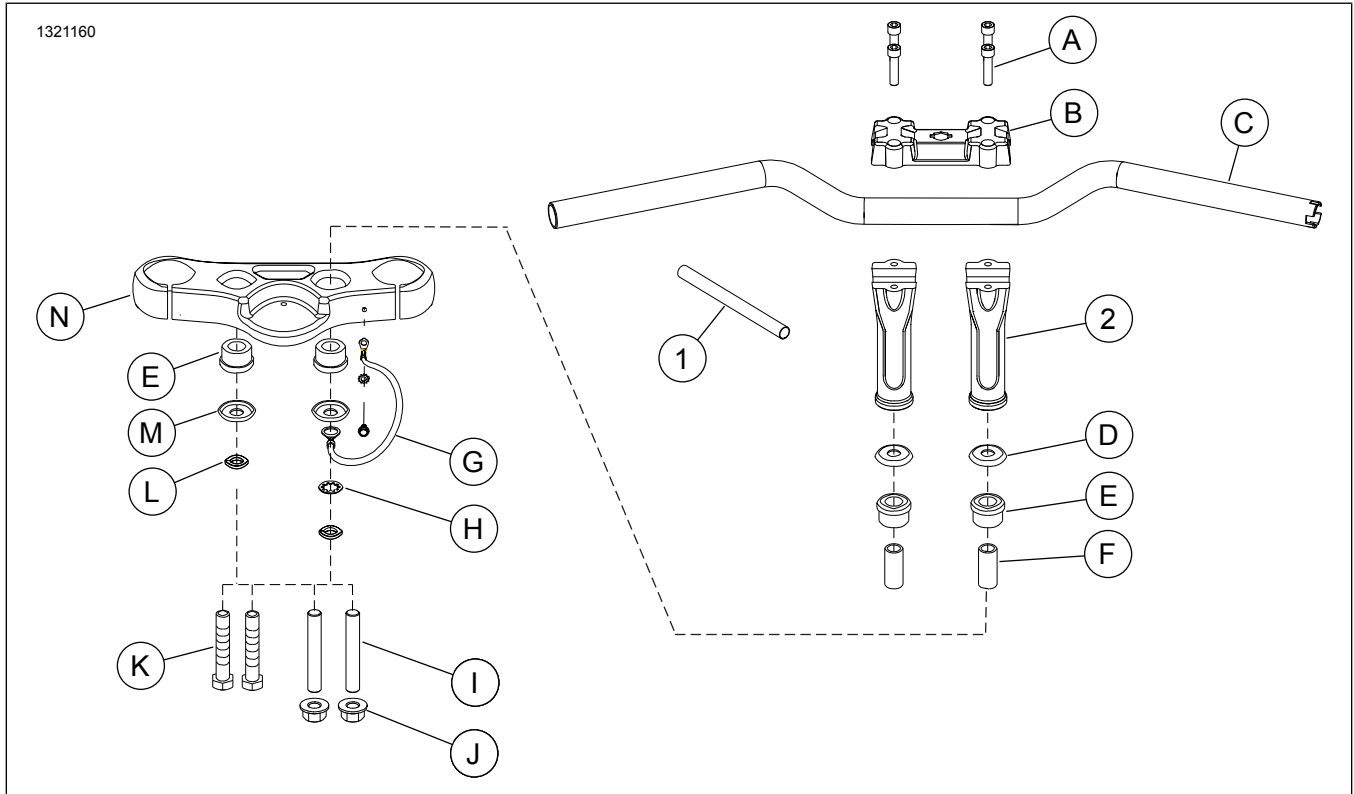

Figure 1. Service Parts List: Tall Riser Kits

Table 2. Kit Contents: Tall Riser Kits

<input checked="" type="checkbox"/>	Item	Qty	Description	Part No.	Notes
<input type="checkbox"/>	1	1	Mesh conduit	69202334	
<input type="checkbox"/>	2	2	Riser, black, 1 inch	Not sold separately	Kit 55800852
<input type="checkbox"/>		2	Riser, black, 1.25 inch	Not sold separately	Kit 55800854
Items mentioned in text but not included in kit:					
<input type="checkbox"/>	A	4	Screw		
<input type="checkbox"/>	B	1	Top clamp		
<input type="checkbox"/>	C	1	Handlebar		
<input type="checkbox"/>	D	2	Upper cup washer		
<input type="checkbox"/>	E	4	Bushing		
<input type="checkbox"/>	F	2	Spacer		
<input type="checkbox"/>	G	1	Ground cable		Touring models only. Install right side.
<input type="checkbox"/>	H	1	Internal tooth lock washer		Touring models only. Install right side.
<input type="checkbox"/>	I	2	Threaded stud		Softail only
<input type="checkbox"/>	J	2	Nut		Softail only
<input type="checkbox"/>	K	2	Riser screw		Road King only.
<input type="checkbox"/>	L	2	Lockwasher		
<input type="checkbox"/>	M	2	Lower cup washer		
<input type="checkbox"/>	N	1	Upper fork bracket		

GENERAL

NOTE

Verify all contents are present in the kit before installing or removing items from vehicle.

Models

Ask a Harley-Davidson dealer or refer to the latest Harley-Davidson Genuine Motor Accessories and Genuine Motor Parts catalog to determine if this riser kit can be installed on your vehicle.

Make sure that you are using the most current version of the instruction sheet which is available at:
www.harley-davidson.com/isheets

Contact Harley-Davidson Customer Support Center at 1-800-258-2464 (U.S. only) or 1-414-343-4056.

NOTE

This instruction sheet references service manual information. A service manual for your model motorcycle is required for this installation and is available from a Harley-Davidson dealer.

Installation Requirements

Proper installation of this kit requires the prior or concurrent installation of an appropriate Harley-Davidson handlebar kit. Contact a Harley-Davidson dealer to determine which kits will fit your model motorcycle.

Separate purchase of additional parts or accessories may be required for proper installation of this kit on your vehicle. Refer to the latest **Harley-Davidson Handlebar Fitment Guide** for a list of required parts.

Loctite® 271 (Red) Threadlocker and Sealant (H-D Part Number 99671-97) is required for the proper installation of this kit.

▲ WARNING

Rider and passenger safety depend upon the correct installation of this kit. Use the appropriate service manual procedures. If the procedure is not within your capabilities or you do not have the correct tools, have a Harley-Davidson dealer perform the installation. Improper installation of this kit could result in death or serious injury. (00333b)

REMOVE

NOTE

Cover fuel tank to prevent damage.

Road King

1. Disassemble handlebar risers.
 - a. Remove and retain two riser screws (K) and lockwashers (L) from underside of upper fork bracket (N).
 - b. Remove and discard four screws (A).
 - c. Remove clamp (B).
 - d. Remove handlebar (C) from risers.
 - e. Remove risers from vehicle.
2. Carefully set handlebar (C) to rest on fuel tank.
 - a. If replacing handlebar, refer to service manual to remove controls, hand levers, handlebar and risers.

Softail

1. Disassemble handlebar risers.
 - a. Remove two nuts (J) and lockwashers (L) from underside of upper fork bracket (N). Retain lockwashers (L).
 - b. Remove and discard four screws (A).
 - c. Remove clamp (B).
 - d. Remove handlebar (C) from risers.
 - e. Remove risers with threaded studs (I) from vehicle.
2. Carefully set handlebar (C) to rest on fuel tank.
 - a. If replacing handlebar, refer to service manual to remove controls, hand levers, handlebar and risers.

INSTALL

Road King and Softail

1.

NOTE

Road King ground cable (G) and internal tooth lock washer (H) are installed on the right side.

Install risers to upper fork bracket.

- a. Align components as shown in Figure 1.
- b. Install riser screws (K). Do not tighten screws at this time.

2. Install Harley-Davidson handlebar:
 - a. Install new handlebar according to Instruction Sheet included with kit.
3. Install riser clamp.
 - a. See Figure 1. Loosely install riser clamp (B) with Bar & Shield facing rider onto handlebar and risers.
 - b. See Figure 2. Install screws 1 and 2.
 - c. Check the gap between the clamp and risers. The gap should only be at the rear of the handlebar (4). There should be no gap at the front of the handlebar (3).
4. Tighten clamp screws.
 - a. Adjust handlebar to desired position.
 - b. Verify handlebar is centered on risers
 - c. See Figure 2. Tighten front screws (1).
Torque: 16–20 N·m (12–15 ft-lbs) *Front top clamp screw*
 - d. Tighten rear screws (2).
Torque: 16–20 N·m (12–15 ft-lbs) *Rear top clamp screw*
5. See Figure 1. Apply threadlocker to riser screws.
 - a. Remove one riser screw (K).
 - b. Apply threadlocker to screw threads.
LOCTITE 271 HIGH STRENGTH THREADLOCKER AND SEALANT (RED) (Loctite 271)
 - c. Install screw.
 - d. Repeat procedure for other screw.
 - e. Check that risers (2) are properly aligned with handlebar (C).
 - f. Tighten screws (K). See service manual.

NOTICE

Improperly aligned handlebars or components can contact the fuel tank when turned to the left or right. Contact with the fuel tank can cause cosmetic damage. (00372b)

6. Turn handlebar full right and left. Check that:
 - a. Handlebar and triple tree clamps do not contact the fuel tank.
 - b. Steering stops function properly.
 - c. Wiring and brake line are not pinched or kinked in the steering assembly.

- d. Throttle returns from full open to close at both fork stops.

⚠ WARNING

Install proper length brake lines. Incorrect brake line length can adversely affect motorcycle operation, which could cause loss of control resulting in death or serious injury. (00325a)

⚠ WARNING

Be sure that steering is smooth and free without interference. Interference with steering could result in loss of vehicle control and death or serious injury. (00371a)

- If you are installing different handlebars, measure the change in distance that will be required from the end of the stock brake line to the brake master cylinder.
- If the line is more than 2.0 in (50.8 mm) longer or more than 1.0 in (25.4 mm) shorter than the above measured distance, see a Harley-Davidson dealer for the correct brake line length.
- Be sure wires, clutch cables, throttle/idle cables and brake lines do not pull tight when handlebars are turned fully to left or right fork stops.

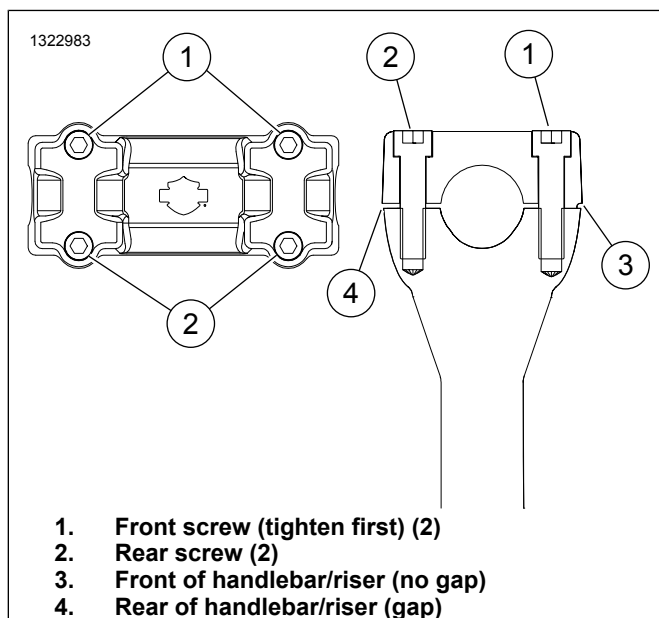

Figure 2. Handlebar Mounting