



INSTRUCTIONS

J04402

2020-01-31



HEATED SEAT KIT

GENERAL

Kit Number

52633-08, 52000004A, 52000135, 52000127, 52000177, 52000564, 52000565

Models

For model fitment information, see the P&A Retail Catalog or the Parts and Accessories section of www.harley-davidson.com (English only).

Installation Requirements

If another accessory is already using the accessory circuit connector (under the seat, See Figure 4.), then a Switched Circuit Adapter Harness (part number 70264-94A) is required.

2014-2016 models: Separate purchase of harness extension (Part No. 69200722) is required to locate the accessory circuit connector.

2017 and later models: Separate purchase of harness extension (Part No. 69201599) is required to locate the accessory circuit connector.

Electrical Overload

NOTICE

It is possible to overload the vehicle's charging system by adding too many electrical accessories. If the combined electrical accessories operating at any one time consume more electrical current than the vehicle's charging system can produce, the electrical consumption can discharge the battery and cause damage to the vehicle's electrical system. (00211d)

⚠ WARNING

When installing any electrical accessory, be certain not to exceed the maximum amperage rating of the fuse or circuit breaker protecting the affected circuit being modified. Exceeding the maximum amperage can lead to electrical failures, which could result in death or serious injury. (00310a)

The Heated Seat requires up to **4.2 Amps** of current from the electrical system.

Kit Contents

See Figure 7 and Table 1 for kit contents.

REMOVAL

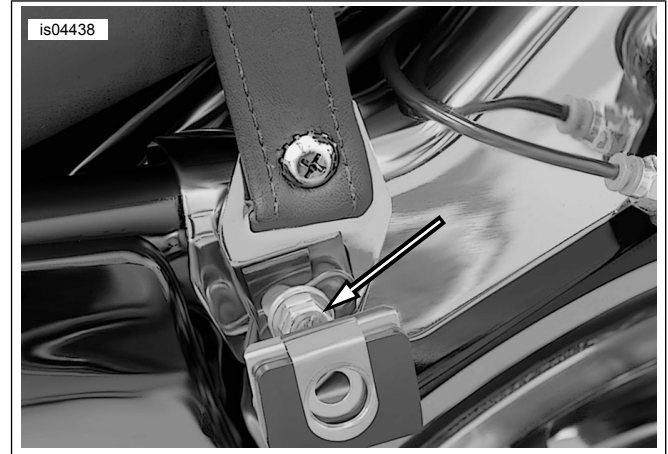

Figure 1. Passenger Grab Strap Removal (2008 Shown)

NOTE

When performing the following procedures, avoid scratching painted surfaces with tools or metal seat tabs.

Grab Strap Removal: 2013 and Earlier Models

1. See the owner's manual. Remove saddlebags. Save all hardware for installation.

2.

NOTE

Before removing the saddlebag-mounting bracket attaching bolts, note the mounting orientation of the saddlebag mounting brackets.

3. See Figure 1. Remove the **left side** forward saddlebag-mounting bracket attaching bolt and washer to remove the bracket and disconnect the currently installed passenger grab strap.
3. Use the bolt and washer to assemble the saddlebag mounting bracket to the vehicle in the same orientation as removed. Snug the bolt enough to hold the bracket in place. Do not fully tighten.
4. Remove the **right side** forward saddlebag-mounting bracket attaching bolt and washer. Remove and discard the grab strap.
5. Assemble the bracket to the vehicle in the same orientation as removed. Snug the bolt enough to hold the bracket in place. Do not fully tighten.



Grab Strap Removal: 2014 and Later Models

1. See Figure 7. Remove screw (D), washer (E) and grab strap end. Save hardware for later installation.
2. Repeat previous step on opposite side.

Seat Removal

1. **Tour-Pak® models:** Open Tour-Pak lid. Lift front pad to access seat mounting.
2. See Figure 7. Remove the Phillips-head screw with lockwasher (A) from the rear of the currently installed seat. Pull the seat rearward to remove the seat. Retain the screw
3. **Fender Strips:** Remove fender trim strips:
 - a. Cover the tip of a regular screwdriver with a piece of tape to protect chrome and painted surfaces.
 - b. See Figure 2. Insert the tip of the screwdriver between the chrome bezel and the rubber trim strip.
 - c. Pry up the bezel. Pull it up and away from the rubber trim strip.
 - d. Starting at either end, peel the rubber trim strip away from the fender.
 - e. Clean with a mixture of 50 percent isopropyl alcohol and 50 percent distilled water.

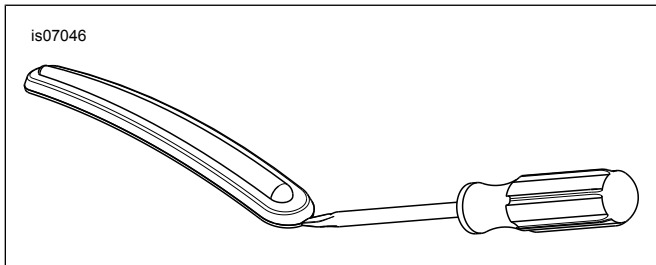

Figure 2. Remove Fender Trim Strip

INSTALLATION

New Seat and Grab Strap Installation

NOTE

Models with a grab rail do not require the installation of a grab strap.

2013 and earlier models: Grab strap is installed before the seat.
2014 and later models: Grab strap is installed after the seat.

1. **2014 and Later Models:** Go to step 3. **2013 and Earlier Models:** See Figure 3. Remove the two hex nuts (2) from the studs near the front of the rear fender.
2. Install **new** grab strap (1) onto the studs as shown, using the two outermost holes on straps with multiple holes. Secure the grab strap to the studs with the nuts. Tighten.
Torque: 6.8–10.8 N·m (5–8 ft-lbs)

▲ WARNING

To prevent accidental vehicle start-up, which could cause death or serious injury, disconnect negative (-) battery cable before proceeding. (00048a)

3. Follow the instructions in the owner's manual to remove the negative (-) battery cable from the battery.

NOTE

2014-2016 models: Installation of Kit 69200722 is required to locate the accessory circuit connector under the seat.

2017 and later models: Installation of Kit 69201599 is required to locate the accessory circuit connector under the seat.

4. See Figure 4. Identify and remove the plug from the accessory circuit connector (1) in front of the battery.

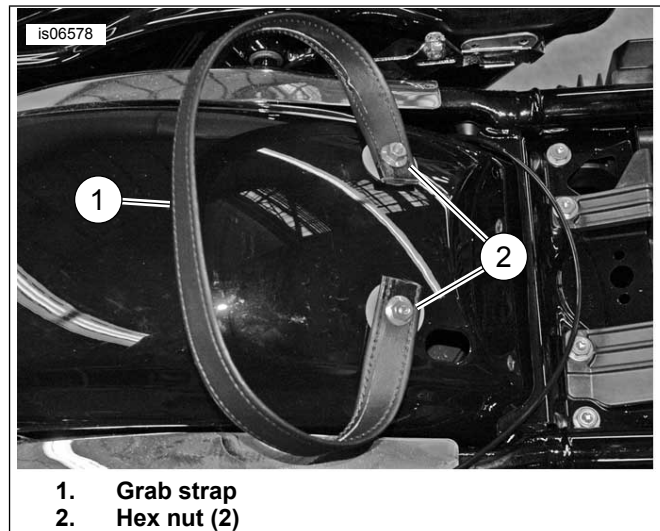

1. Grab strap
2. Hex nut (2)

Figure 3. Grab Strap Installation

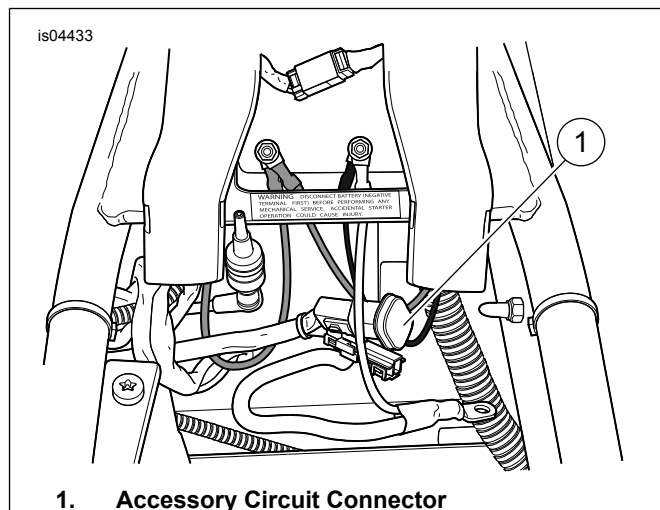

1. Accessory Circuit Connector

Figure 4. Accessory Circuit Connector

5. Locate the heated seat connector on the underside of the **new** seat.

NOTE

2014-2016 models: If another accessory is already using the accessory circuit connector, use a Switched Circuit

Adapter Harness (part number 70264-94A, available separately) as a "Y" adapter.

2017 and later models: If another accessory is already using the accessory circuit connector, use a Switched Circuit Adapter Harness (part number 69201706, available separately) as a "Y" adapter.

6. Connect the heated seat connector to the accessory circuit connector (1).
7. See the owner's manual. Connect the negative (-) battery cable.
8. Guide the wiring into the space beneath the seat so that the wiring will not be crimped when the seat is installed.
9. See Figure 5. If already installed, slide the rear of the seat through the grab strap, from the front, until the slot (2) on the front underside of the seat is behind the seat mounting tongue (1) on the fuel tank rear bracket.

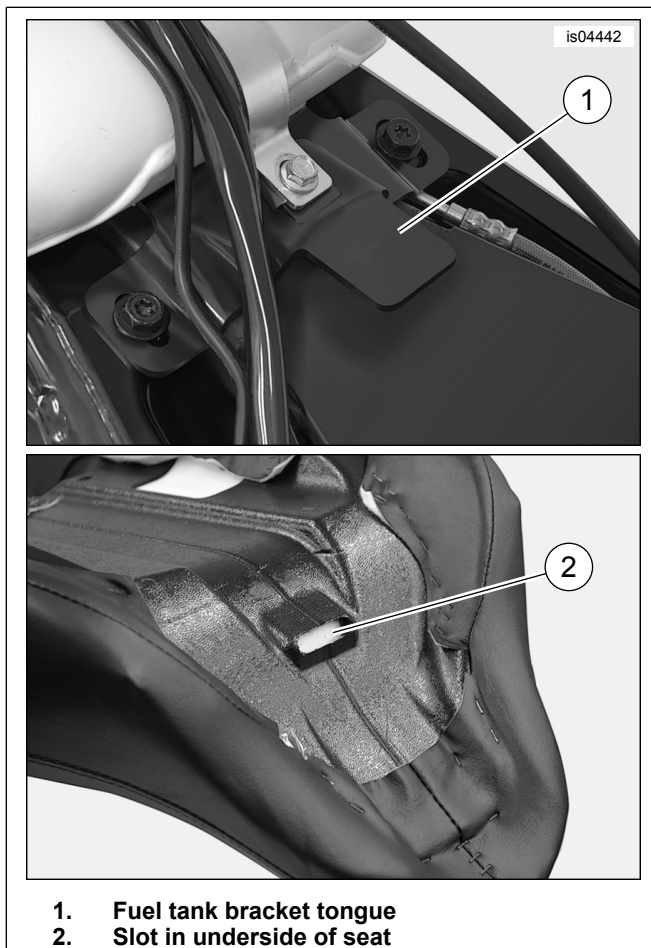

Figure 5. Seat Front Mounting

10. Press the seat down onto the frame backbone. Slide the seat toward the front of the motorcycle until the fuel tank bracket tongue fully engages into the slot under the seat.
11. Secure the seat onto the rear fender using the Phillips-head screw (with lockwasher) removed in Seat Removal. Tighten.
Torque: 5.4–8.1 N·m (4–6 ft-lbs)

12. See service manual. Install seat. After installing seat, pull up on the seat to verify that it is secure.

13. **2014 and Later Models:** Install grab strap.

- a. Install grab strap end into grab strap bracket slot. Align the grab strap hole with the bracket hole.
- b. See Figure 7. Install grab strap screw (D) and washer (E). Tighten.
Torque: 5.4–8.1 N·m (4.0–6.0 ft-lbs)
- c. Repeat steps for the opposite side.

NOTE

The molded rubber insert at the bottom of the saddlebags must fit snugly on the lower saddlebag support rails.

14. If removed, install the saddlebags to the motorcycle per the instructions in the owner's manual. Secure with the original bail head studs and flat washers.

15. Tighten the forward saddlebag mounting bolts. Tighten.

Torque: 7–11 N·m (62.0–97.4 in-lbs)

OPERATION

NOTE

The accessory switch is a rocker switch found on the inner fairing switch panel.

1. With the ignition/key switch at IGNITION or ACCESS, open the circuit to the heated seat by flipping the accessory switch from OFF to ON.
2. Two switches on the side of the seat control the rider and passenger heating areas independently. The forward switch controls the rider area, and the rearward switch controls the passenger area.
 - In the center position, the heat to that area of the seat is OFF.
 - Pressing the lower part of the switch in toward the seat turns the heat in that area ON at the LOW setting.
 - Pressing the upper part of the switch in toward the seat turns the heat in that area ON at the HIGH setting.

NOTE

If the accessory switch is left ON and a seat heater rocker switch is left in either the LOW or HIGH position when the motorcycle is turned off, the seat will begin heating when the ignition/key switch is turned to the IGNITION or ACCESS position.

A seat heater in operation while the motorcycle engine is turned off or running below normal operating speed can quickly discharge the vehicle battery, which could lead to a subsequent failure to start, and could damage the electrical system.

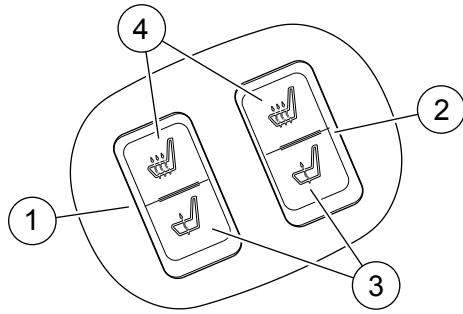

1. Rider section heat control switch
2. Passenger section heat control switch
3. Low heat position
4. High heat position

Figure 6. Seat Heating Control Switches

SERVICE PARTS

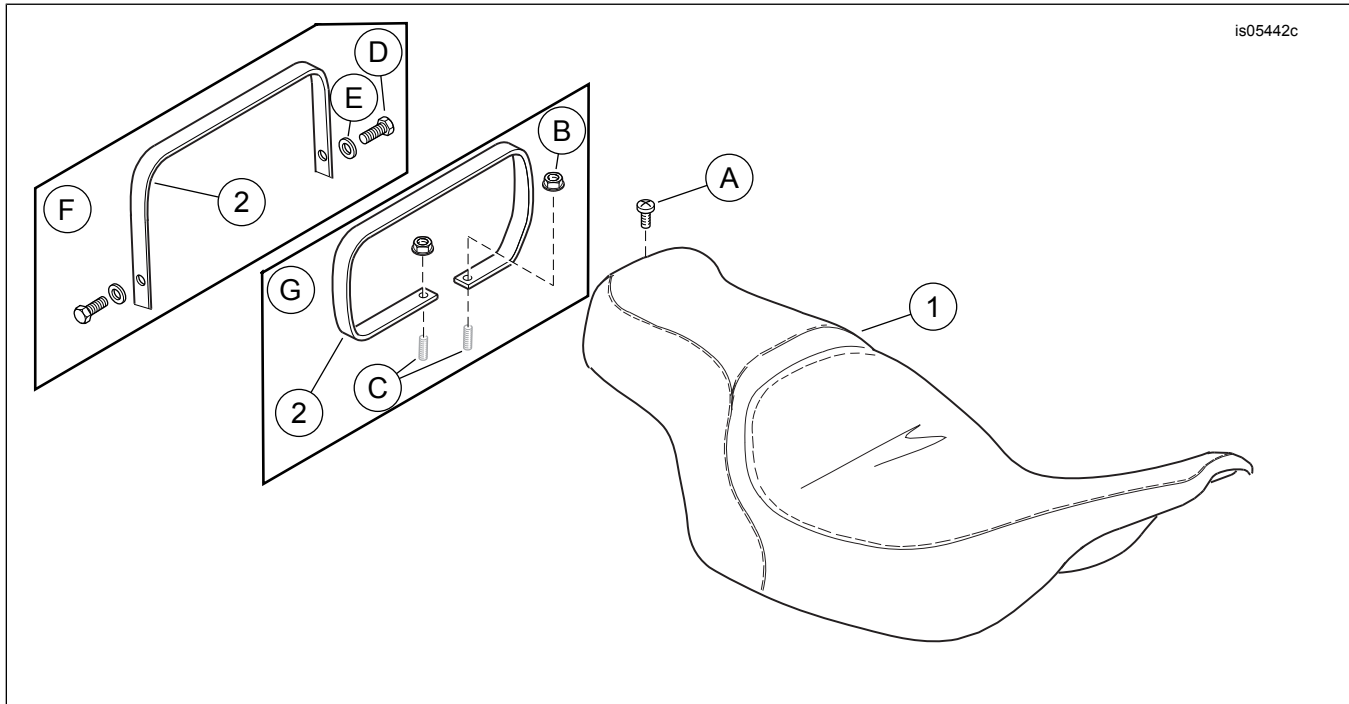

Figure 7. Service Parts: Heated Seat

Table 1. Service Parts Table

Item	Description (Quantity)	Part Number
1	Seat (plain pattern shown)	Not sold separately
2	Grab strap (Kit 52633-08)	51188-86
	Grab strap (Kits 5200004A, 52000177, 52000564 and 52000565)	52400005
	Grab strap (Kits 52000127 and 52000135)	52400015
Items mentioned in text, but not included in kit:		
A	Original equipment (OE) Phillips-head screw	2952A
B	OE flanged nut (2)	7499
C	OE stud (2)	Not sold separately
D	OE Grab strap screw (2)	2952A
E	OE Grab strap washer (2)	6703
F	2014 and later model configuration	
G	2013 and earlier model configuration	