



INSTRUCTIONS

94100051

2022-02-24



TOP CASE MOUNTING KIT

GENERAL INFORMATION

Table 1. General Information

Kits	Suggested Tools	Skill Level ⁽¹⁾
53000800	Safety Glasses, Torque Wrench	

(1) Tightening to torque value or other moderate tools and techniques required

KIT CONTENTS

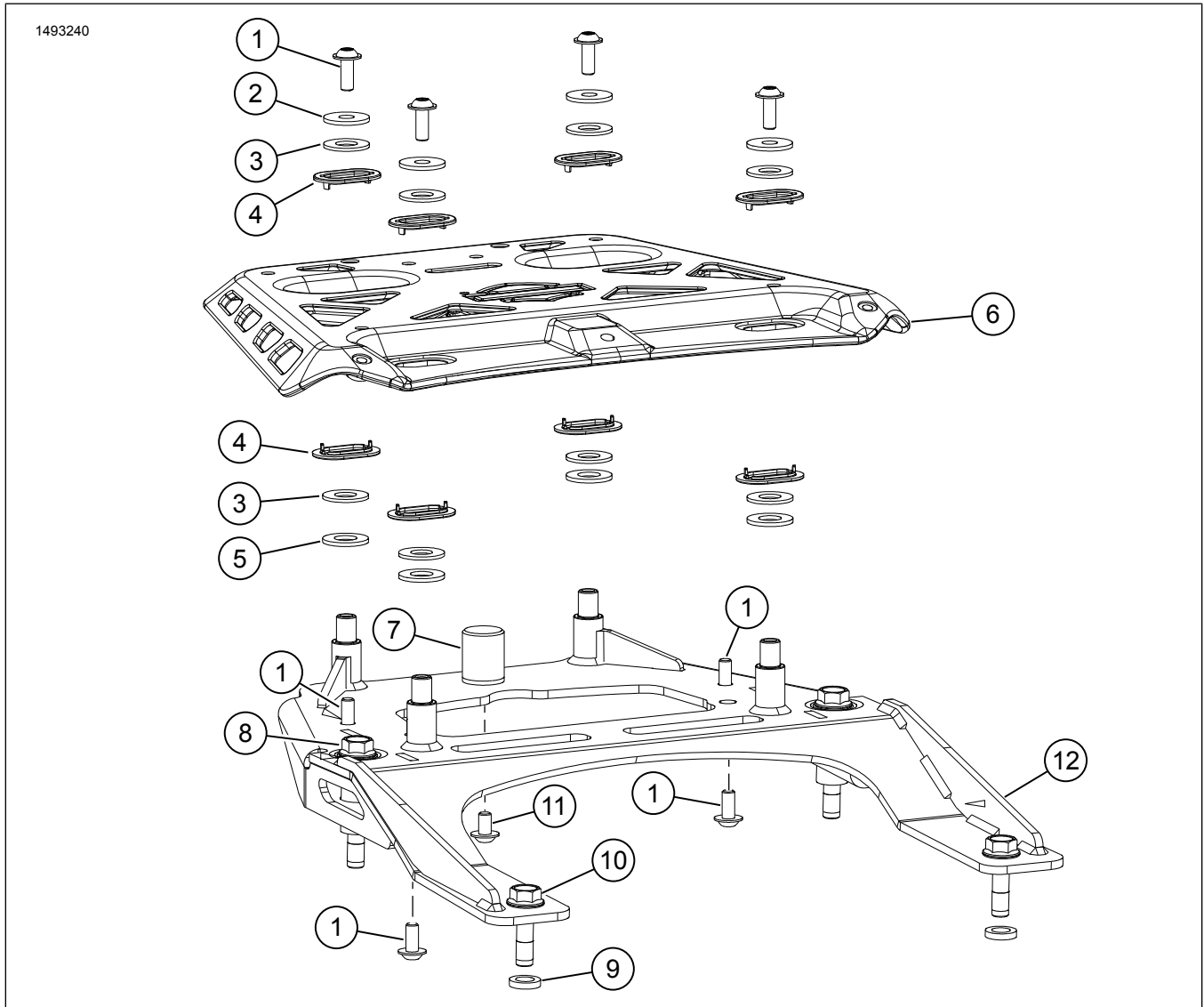

Figure 1. Kit Contents: Top Case Mounting

Table 2. Kit Contents: Top Case Mounting

<input checked="" type="checkbox"/>	Verify that all contents are present in the kit before installing or removing items from vehicle.				
Item	Qty	Description	Part No.	Notes	
<input type="checkbox"/>	1	8	Flange button head screw, M6 x 1.0 x 16	10200924	
<input type="checkbox"/>	2	4	Washer, flat, M6	53000800_17	Part of service kit (Part No. 53000902)
<input type="checkbox"/>	3	8	Washer, plastic	53000800_12	Part of service kit (Part No. 53000902)
<input type="checkbox"/>	4	8	Plastic slide	53000800_09	Part of service kit (Part No. 53000902)
<input type="checkbox"/>	5	4	Washer, custom, M10	53000800_27	Part of service kit (Part No. 53000902)
<input type="checkbox"/>	6	1	Top plate	53000850	
<input type="checkbox"/>	7	1	Bumper	53000918	Not serviced individually
<input type="checkbox"/>	8	2	Hex flange screw, M8 x 60	10201265	
<input type="checkbox"/>	9	2	Spacer	12400219	
<input type="checkbox"/>	10	2	Hex flange screw, M8 x 30	10201294	
<input type="checkbox"/>	11	1	Flange button head screw, M6 x 1.0 x 10	10201050	
<input type="checkbox"/>	12	1	Mounting bracket	53000844	Not serviced individually

GENERAL

Models

For model fitment information, see the Parts and Accessories (P&A) Retail Catalog or the Parts and Accessories section of www.harley-davidson.com.

Verify that the most current version of the instruction sheet is used. It is available at: h-d.com/isheets

Contact Harley-Davidson Customer Support Center at 1-800-258-2464 (U.S. only) or 1-414-343-4056.

Installation Requirements

▲ WARNING

Rider and passenger safety depend upon the correct installation of this kit. Use the appropriate service manual procedures. If the procedure is not within your capabilities or you do not have the correct tools, have a Harley-Davidson dealer perform the installation. Improper installation of this kit could result in death or serious injury. (00333b)

NOTE

This instruction sheet references service manual information. A service manual for the year and model motorcycle is required for this installation and is available from:

- A Harley-Davidson dealer.
- H-D Service Information Portal, a subscription-based access available for most 2001 and newer models. For more information see *Frequently ask questions about subscriptions*.

PREPARE

1. See Figure 2. Remove seat pillion (1) and seat (2). See service manual.

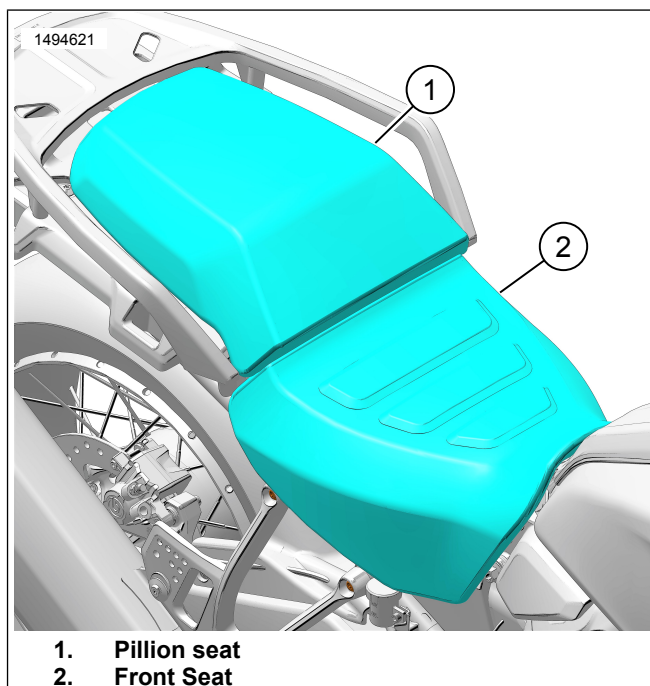

Figure 2. Seat

REMOVE

NOTE

Tail light harness and latch cable are attached to handhold base with cable straps.

1. See Figure 3. Remove handhold base screws (3).
2. See Figure 4. Remove and discard cable straps (2).
3. See Figure 4. Remove tail light (3).
 - a. Disconnect tail light connector (5)
 - b. See Figure 3. Remove screws (1).
4. See Figure 4. Remove seat latch (6).
 - a. See Figure 3. Remove seat latch screws (2).
5. See Figure 4. Remove handhold (1) from handhold base (7).
 - a. Remove handhold screw (4).
6. See Figure 5. Drill clearance holes (1).
 - a. Drill four pilot holes.
3 mm (0.125 in)
 - b. Drill four holes.
20 mm (0.787 in)

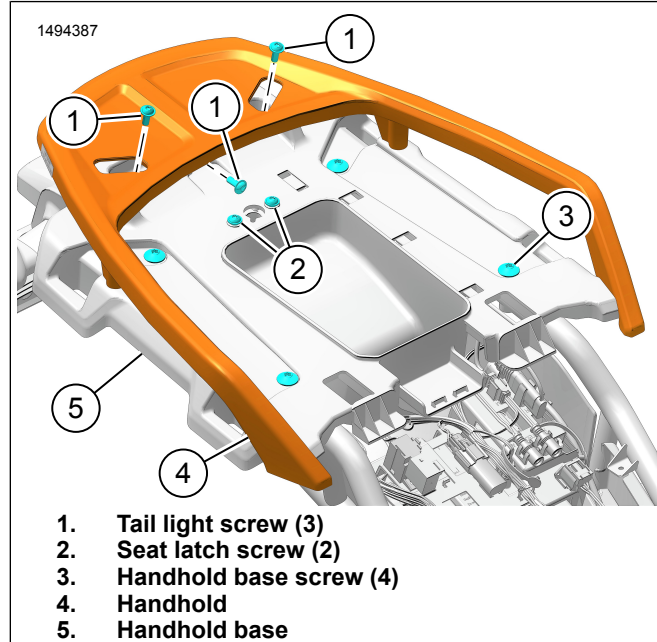

Figure 3. Hand Hold

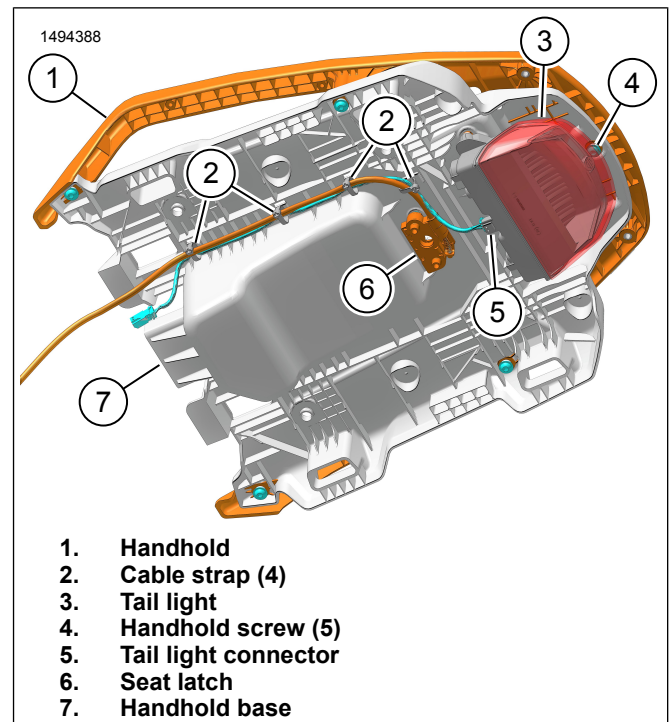

Figure 4. Disassemble Handhold Base

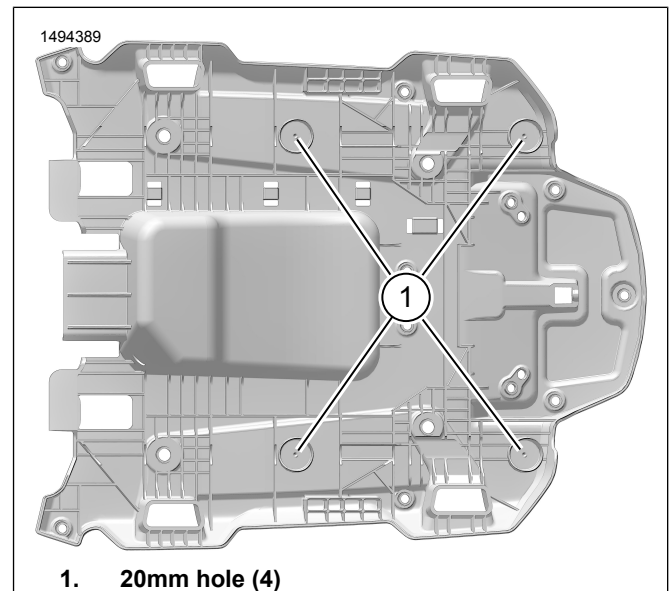

Figure 5. Handhold Base Holes

INSTALL

1. See Figure 4. Install seat latch (6).
 - a. See Figure 6. Install seat latch screws (3). Tighten.
Torque: 8–10 N·m (5.9–7.4 ft-lbs) *Seat latch screws*
2. See Figure 4. Install tail light (3).
 - a. See Figure 6. Install tail light screws (2). Tighten.
Torque: 7–9 N·m (5.2–6.6 ft-lbs) *Tail light screws*
 - b. Connect tail light connector (5)

3. See Figure 4. Route seat latch cable and tail light harness. Secure with **new** cable straps (2).

4. See Figure 6. Install handhold base (1).

a. Install handhold base screws (4). Tighten.

Torque: 28.5–32.5 N·m (21.0–24.0 ft-lbs) *Handhold base screws*

5. See Figure 8. Install bumper (2) and screw (1) to mounting bracket (3).

a. Tighten screw (1).

Torque: 9–11.5 N·m (6.6–8.5 ft-lbs) *Bumper screw*

6. See Figure 7. Install spacers (2) into handhold base (1).

7. See Figure 8. Install mounting bracket (3).

a. Loosely install screws (4, 5).

b. See Figure 9. Install handhold base to mounting bracket screws (5). Tighten.

Torque: 9–11.5 N·m (6.6–8.5 ft-lbs) *Handhold base to mounting bracket screws*

c. See Figure 8. Tighten screws (4, 5).

Torque: 32.5 N·m (24.0 ft-lbs) *Mounting bracket screws*

8. See Figure 10. Install handhold (2).

a. Loosely install screws (1) on both sides.

b. See Figure 9. Install handhold base to handhold screws (4).

c. Tighten all screws.

Torque: 7–8 N·m (5.2–5.9 ft-lbs) *Handhold screws*

9. **NOTE**

Follow the torque specification for the top plate installation. The top case will have some side-to-side movement by design. Failure to follow instructions could result in damage to components.

See Figure 11. Install top plate.

a. Install custom washers (6), plastic washers (5) and plastic slides (4) onto mounting bracket (7).

b. Install top plate (8).

c. Install plastic slides (4), plastic washers (3), flat washers (2) and screws (1).

d. Tighten screws (1).

Torque: 9.5 N·m (7.0 ft-lbs) *Top plate screws*

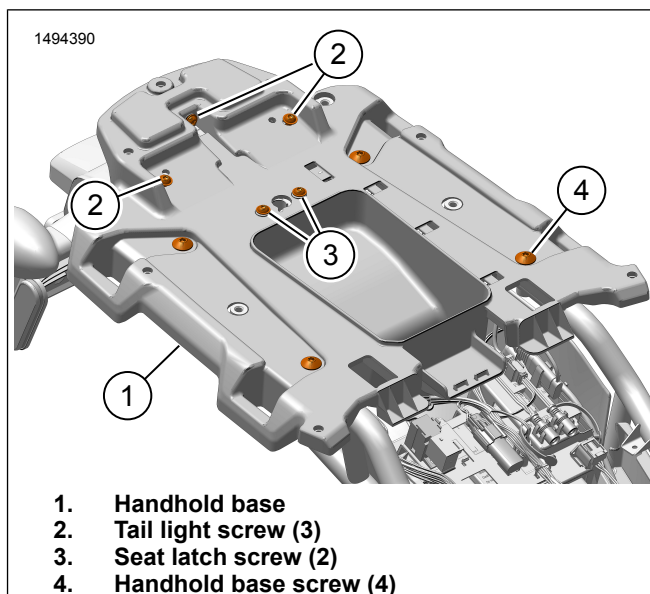

Figure 6. Install Handhold Base

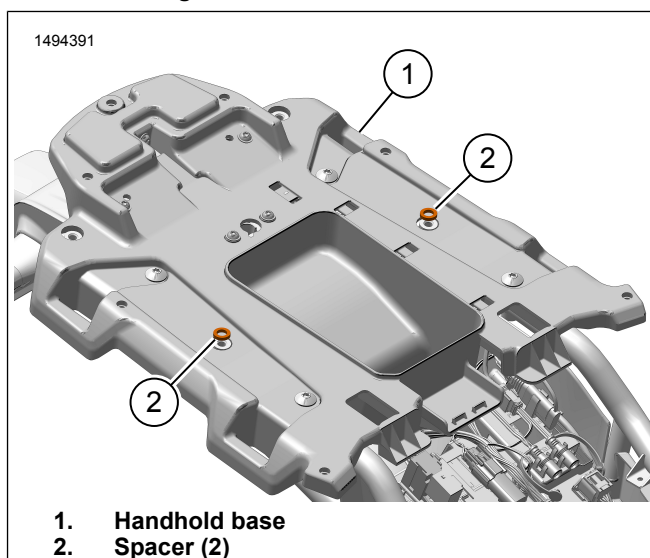

Figure 7. Spacers

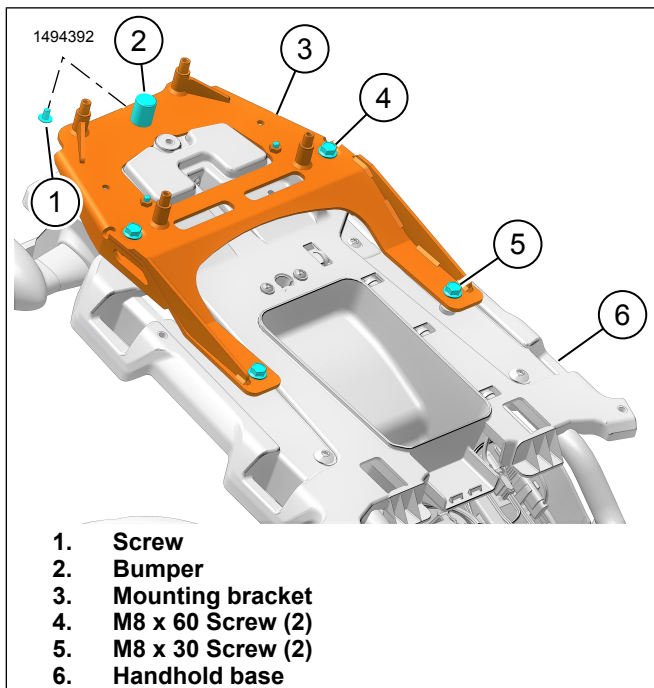

Figure 8. Mounting Bracket

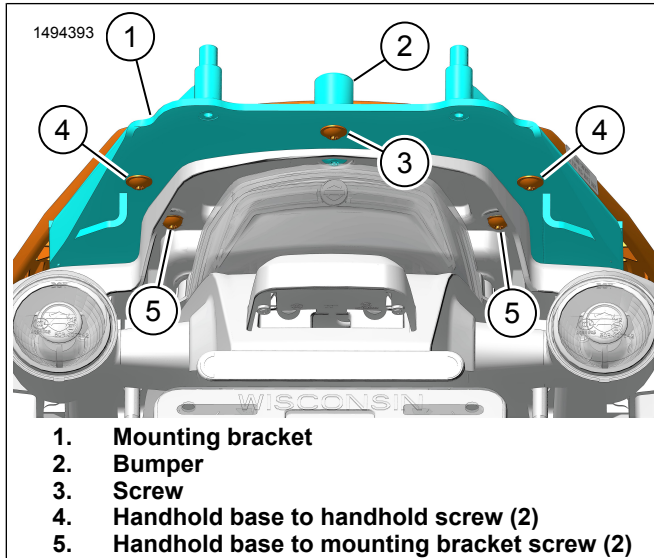

Figure 9. Rear Mounting Screws

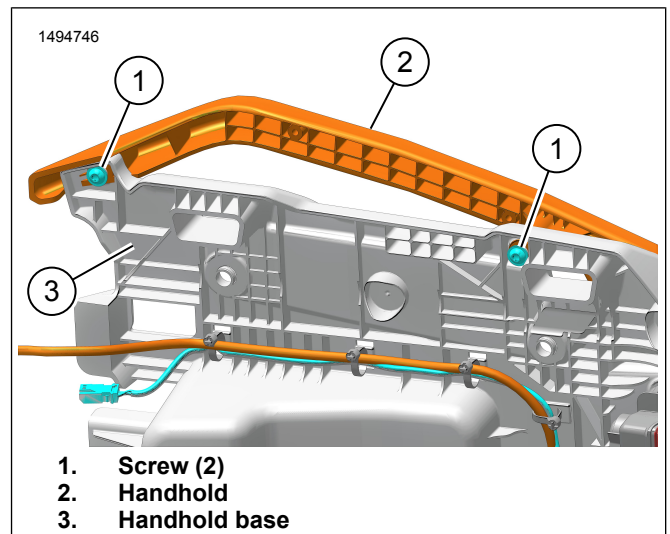

Figure 10. Handhold

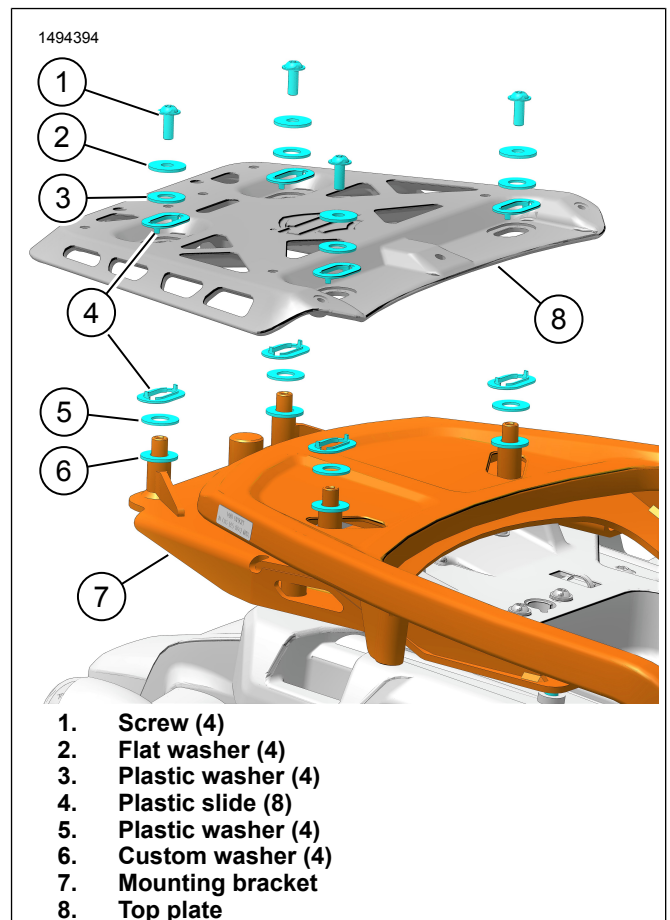

Figure 11. Top Plate Hardware

COMPLETE

1. See Figure 2. Install seat (2) and seat pillion (1). After installing seat, pull up on seat to verify that it is secure. See service manual.