



# INSTRUCTIONS

94100423

2023-01-09



## 120TH ANNIVERSARY AIR CLEANER COVER MEDALLION

### GENERAL INFORMATION

Table 1. General Information

Kits	Suggested Tools	Skill Level <sup>(1)</sup>
61301327	Safety Glasses, Torque Wrench	

(1) Tightening to torque value or other moderate tools and techniques required

### KIT CONTENTS

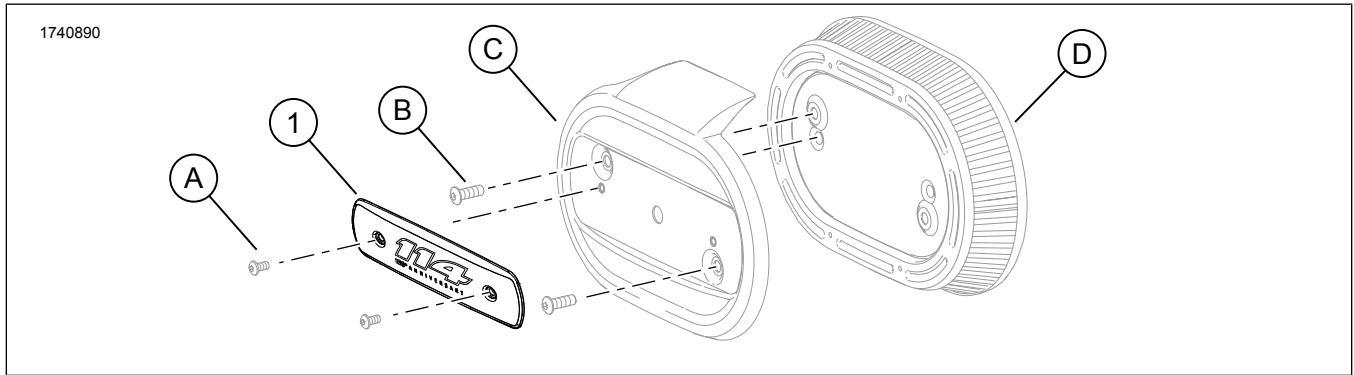

Figure 1. Kit Contents: 120th Anniversary Air Cleaner Cover Medallion

Table 2. Kit Contents: 120th Anniversary Air Cleaner Cover Medallion Kit

Verify that all contents are present in the kit before installing or removing items from vehicle.					
<input checked="" type="checkbox"/>	Item	Qty	Description	Part No.	Notes
<input type="checkbox"/>	1	1	Insert, 120th anniversary	Not sold separately	
<b>Items mentioned in text, but not included in kit</b>					
<input checked="" type="checkbox"/>	A	2	Original Equipment (OE) screw, insert		
<input checked="" type="checkbox"/>	B	2	OE screw, air cleaner cover		
<input checked="" type="checkbox"/>	C	1	OE air cleaner cover		
<input checked="" type="checkbox"/>	D	1	OE air cleaner element		

### GENERAL

#### Models

For model fitment information, see the Parts and Accessories (P&A) Retail Catalog or the Parts and Accessories section of [www.harley-davidson.com](http://www.harley-davidson.com).

Verify that the most current version of the instruction sheet is used. It is available at: [h-d.com/isheets](http://h-d.com/isheets)

Contact Harley-Davidson Customer Support Center at 1-800-258-2464 (U.S. only) or 1-414-343-4056.

### Installation Requirements

#### ⚠ WARNING

Rider and passenger safety depend upon the correct installation of this kit. Use the appropriate service manual procedures. If the procedure is not within your capabilities or you do not have the correct tools, have a Harley-Davidson dealer perform the installation. Improper installation of this kit could result in death or serious injury. (00333b)

#### NOTE

This instruction sheet references service manual information. A service manual for the year and model motorcycle is required for this installation and is available from:

- *A Harley-Davidson dealer.*
- *H-D Service Information Portal, a subscription-based access available for most 2001 and newer models. For more information see Frequently ask questions about subscriptions.*

## **REMOVE**

1. Remove main fuse. See service manual.
2. Carefully remove OE screws (A) and air cleaner cover insert (1) from air cleaner. Discard cover insert.

## **INSTALL**

1. Position **new** air cleaner cover insert (1).
2. Install OE screws (A). Tighten.  
Torque: 3.1–3.6 N·m (27–32 **in-lbs**)

## **COMPLETE**

1. Install main fuse. See service manual.