



# INSTRUCTIONS

94100394

2024-07-10



## HEATED HAND GRIPS

### GENERAL INFORMATION

Table 1. General Information

Kits	Suggested Tools	Skill Level <sup>(1)</sup>
56100574, 56100575, 56100619, 56100713, 56100714	Safety Glasses, Torque Wrench	
<i>(1) Tightening to torque value or other moderate tools and techniques required</i>		

### KIT CONTENTS

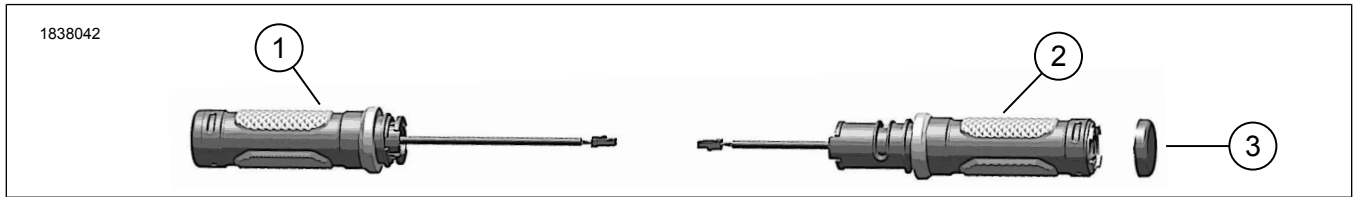

Figure 1. Kit Contents: Heated Hand Grips

Table 2. Kit Contents: Heated Hand Grips Kit

<input checked="" type="checkbox"/>	Verify that all contents are present in the kit before installing or removing items from vehicle.					
	Kit	Item	Qty	Description	Part No.	Notes
<input type="checkbox"/>	56100574, Switch-back, heated (black)	1	1	Grip, left, black	56100578	
<input type="checkbox"/>		2	1	Grip, right, black	56100576	
<input type="checkbox"/>		3	1	End cap, right	56100598	
<input type="checkbox"/>	56100575, Switch-back, heated (silver)	1	1	Grip, left	56100579	
<input type="checkbox"/>		2	1	Grip, right	56100577	
<input type="checkbox"/>		3	1	End cap, right	56100599	
<input type="checkbox"/>	56100619 (black)	1	1	Grip, left	56100580A	
<input type="checkbox"/>		2	1	Grip, right	56100581A	
<input type="checkbox"/>		3	1	End cap, right	Not sold separately	
<input type="checkbox"/>	56100713, Kahuna, heated (black)	1	1	Grip, left	56100717	
<input type="checkbox"/>		2	1	Grip, right	56100715	
<input type="checkbox"/>		3	1	End cap, right	56100337	
<input type="checkbox"/>	56100714, Kahuna, heated (chrome)	1	1	Grip, left	56100718	
<input type="checkbox"/>		2	1	Grip, right	56100716	
<input type="checkbox"/>		3	1	End cap, right	56100329	

## GENERAL

Instruction sheet is also available electronically. To verify you are using the most current version available, do one of the following:

- Go to [h-d.com/isheets](http://h-d.com/isheets)
- Scan QR code in upper left corner of the instruction sheet

### NOTE

This instruction sheet **may have a Supplemental Video** to assist installer in clarifying a certain part of the assembly. A linked video would be located at the end of this instruction sheet.

## Models

For model fitment information, see the Parts and Accessories (P&A) Retail Catalog or the Parts and Accessories section of [www.harley-davidson.com](http://www.harley-davidson.com).

Contact Harley-Davidson Customer Support Center at 1-800-258-2464 (U.S. only) or 1-414-343-4056.

## Installation Requirements

### ▲ WARNING

Rider and passenger safety depend upon the correct installation of this kit. Use the appropriate service manual procedures. If the procedure is not within your capabilities or you do not have the correct tools, have a Harley-Davidson dealer perform the installation. Improper installation of this kit could result in death or serious injury. (00333b)

Heated Hand Grips are a Plug-n-Play item and DIGITAL TECHNICIAN II (PART NUMBER: HD-48650) is not required.

- Some 2024 CVO™ Road Glide® ST, Street Glide and Road Glide models may require a Digital Technician update by Harley-Davidson dealer. Refer to PLUG and PLAY HAND CONTROL SOFTWARE CONFIRMATION.

### NOTE

This instruction sheet references service manual information. A service manual for the year and model motorcycle is required for this installation and is available from:

- A Harley-Davidson dealer.
- H-D Service Information Portal, a subscription-based access available for most 2001 and newer models. For more information see Frequently ask questions about subscriptions.

## PLUG and PLAY HAND CONTROL SOFTWARE CONFIRMATION

### NOTE

**2024 Models Affected:** Street Glide (FLHX), Road Glide (FLTRX), CVO Road Glide ST (FLTRXSTSE)

1. Remove cover from Right Hand Control Module (RHCM) or Left Hand Control Module (LHCM). See service manual.

2. Locate label with two rows of numbers (1).
  - a. If the top number has a suffix letter, Auto-Learn for heated hand grips is enabled.
  - b. If the top number does not have a suffix letter, then a re-flash is required using:  
Special Tool: DIGITAL TECHNICIAN II (HD-48650)
  - c. Connect the motorcycle to Digital Technician II (DT II).
  - d. Proceed to Toolbox at the top menu.
  - e. **Select:** Vehicle Setup. Located in left side menu.
  - f. **Select:** LHCM/RHCM Customization.
  - g. **Select:** Enabled. For Heated Grips on both Right and Left Hand Control Modules (R&LHCMs).
  - h. **Select:** Update Vehicle. Located at bottom of screen.
  - i. Disconnect vehicle from DT II.
3. Install cover to RHCM or LHCM. See service manual.

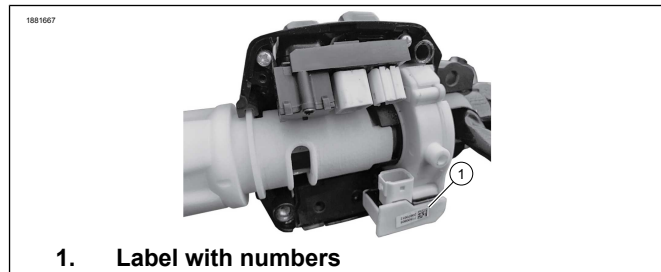

1. Label with numbers

Figure 2. Right Hand Control Module

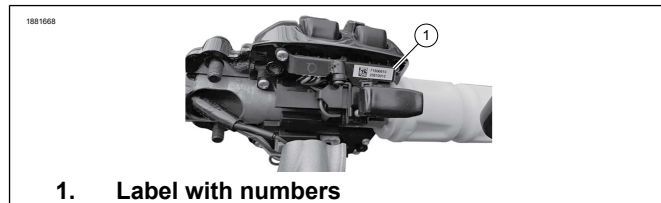

1. Label with numbers

Figure 3. Left Hand Control Module

## PREPARE

1. Remove left saddlebag. See service manual.
2. Remove left side cover. See service manual.
3. Remove main fuse. See service manual.
4. Remove clutch handle assembly. See service manual.
5. Remove white plastic shipping sleeve from inside both right and left heated grips.

## REMOVE

### Left

1. See Figure 4. Remove clutch lever bracket.
  - a. Slide rubber boot (5) back.
  - b. Disconnect clutch switch connector (4).
  - c. Remove screws (1).
  - d. Remove washers (2).
  - e. Remove clutch lever bracket (3).
  - f. Secure bracket out of the way.

#### NOTE

*Protect cosmetic surfaces.*

2. See Figure 5. Remove LHCM cover.
  - a. Remove screws (3).
  - b. Remove cover (2).
3. See Figure 6. Disconnect connectors.
  - a. Disconnect LHCM connector (7).
  - b. Disconnect heated hand grip connector (6).
  - c. Remove cables (1,3) from LHCM cable guide (2).
4. See Figure 7. Remove left heated hand grip (2) while feeding heated hand grip connector (3) through cable opening (4).
5. Remove LHCM (1).

### Right

1. See Figure 8. Remove brake lever bracket.
  - a. Slide rubber boot (3) off connector.
  - b. Disconnect brake switch connector (4).
  - c. Remove screws (2).
  - d. Remove washers (1).
  - e. Remove brake lever bracket (5).

#### NOTE

*Do not allow master cylinder to be positioned upside down.*

- f. Secure bracket out of the way.
2. See Figure 9. Remove RHCM cover.
    - a. Remove screws (1).

- b. Remove cover (2).

3. See Figure 10. Disconnect connectors.
  - a. Disconnect brake lever switch connector (6).
  - b. Disconnect heated hand grip connector (5).
  - c. Disconnect twist grip sensor connector (3).
4. See Figure 11. Remove right heated hand grip.
  - a. Open wire bridge (5).
  - b. Remove hand grip (1) while feeding hand grip connector (4) through cable opening (3).
  - c. Remove hand grip (1).
5. Remove RHCM (2).

## INSTALL

#### NOTE

- *When routing and closing Right and Left Hand Control Modules (R&LHCMs), verify there are no pinched wires. Do not over tighten rear switch housings. See service manual.*
- *Protect cosmetic surfaces.*

### Left

1. Install left heated hand grip.
  - a. Feed heated handle bar cable through handle bar while guiding left heated hand grip (2).
  - b. Pull heated hand grip connector (3) out through cable opening (4).
  - c. See Figure 6. Install lip of grip in groove (4) on LHCM.
2. See Figure 7. Install LHCM (1) on handlebar.
3. See Figure 6. Connect connectors.
  - a. Connect heated hand grip connector (6).
  - b. Route LHCM cable (3) onto LHCM cable guide (2).
  - c. Connect LHCM connector (7).
4. See Figure 5. Install cover.
  - a. Guide clutch switch cable (1) through cover opening (5).

#### NOTE

*Carefully install clutch lever to not damage the clutch switch. See service manual.*

- b. Install LHCM rear cover (2).

#### NOTE

*Do not remove alignment screw.*

- c. Align alignment screw (4) with alignment hole in handlebar.
- d. Verify alignment screw is properly engaged into hole in handle bar.

**NOTE**

*Failure to do this may result in damage to cover.*

- e. Install screws (3). Tighten.  
Torque: 4–5.1 N·m (35–45 in-lbs) *Do not over tighten.*
- f. If alignment screw was removed install and snug alignment screw (4).

5. See Figure 4. Install clutch lever bracket.

- a. Place clutch lever bracket (3) on LHCM bracket.
- b. Install screws (1) and align gap (6) with alignment Mark (7).

**NOTE**

*Gap on LHCM must not be rotated past alignment mark.*

- c. Tighten top screw first.  
Torque: 10–11 N·m (89–97 in-lbs)
- d. Tighten bottom screw.  
Torque: 10–11 N·m (89–97 in-lbs)
- e. Connect clutch switch connector (4).
- f. Slide rubber boot (5) over connector.

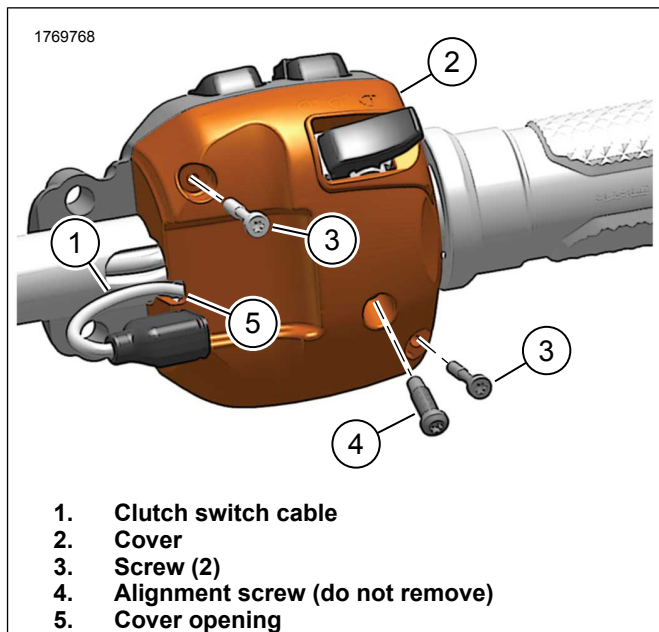

**Figure 5. LHCM Cover**

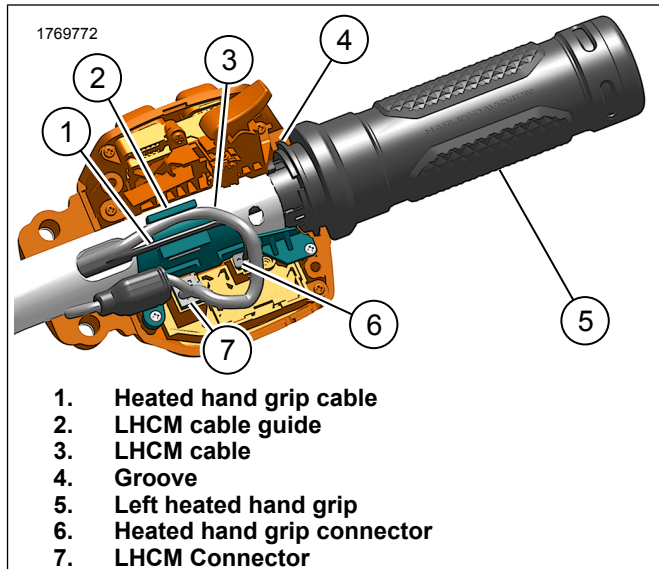

**Figure 6. LHCM Connections**

**NOTE**

*LHCM and grip will not go together unless pre-assembled as shown in Figure 6.*

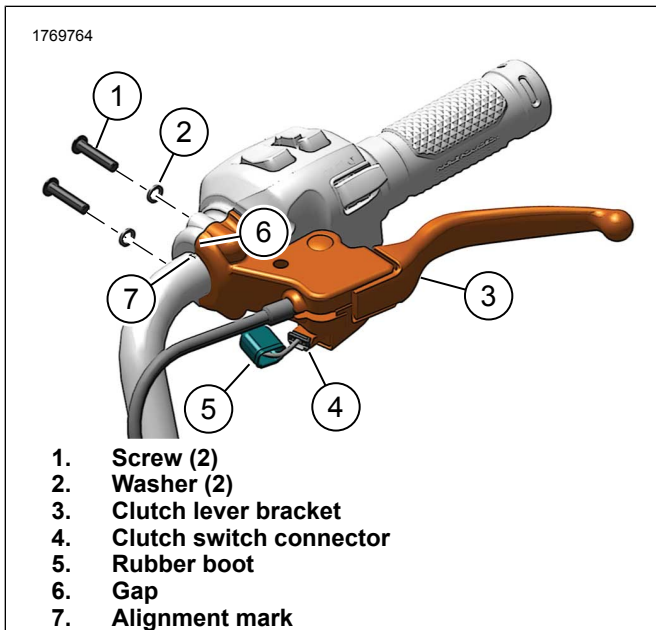

**Figure 4. Clutch Lever Bracket**

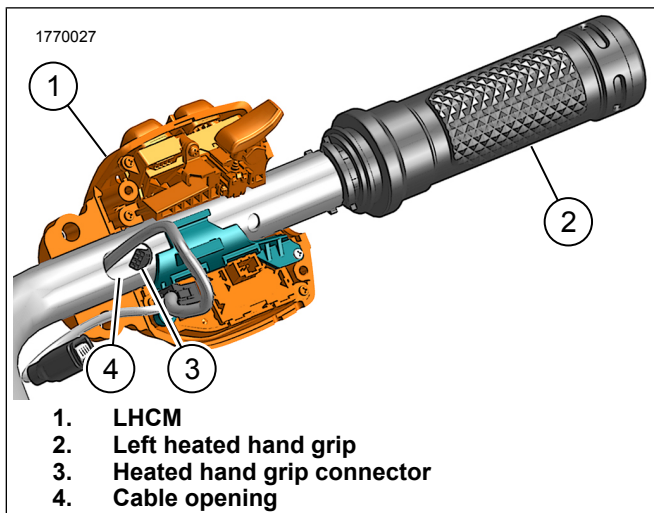

Figure 7. Left Grip Removal/Install

## Right

1. See Figure 11. Install right heated hand grip.
  - a. Feed hand grip cable through handle bar while guiding right hand grip (1).
  - b. Pull hand grip connector (4) out through cable opening (3).
  - c. See Figure 10. Install lip (2) of grip in groove (1) on RHCM.
  - d. Close wire bridge (8).
2. Install RHCM (2) on handlebar.
3. See Figure 10. Connect connectors.
  - a. Connect twist grip sensor connector (3).
  - b. Connect brake lever switch connector (6).
  - c. Connect heated hand grip connector (5).
4. Install cover.
  - a. See Figure 10. Verify cables are between cover supports (7).
  - b. See Figure 9. Guide cables through cover opening (3).
  - c. Install cover (2).
  - d. Install screws (1). Tighten.  
Torque: 4–5.1 N·m (35–45 in-lbs) *Do not over tighten.*
5. See Figure 8. Install brake lever bracket.
  - a. Place brake lever bracket (5) on RHCM bracket.
  - b. Install washers (1).

- c. Install screws (2) and align gap (6) with alignment mark (7).

### NOTE

- When installing RHCM, verify throttle end play is set correctly. See service manual.
- Gap must not be rotated past alignment mark. Do not push master cylinder control assembly inboard past alignment mark.

- d. Tighten top screw first.  
Torque: 10–11 N·m (89–97 in-lbs)
- e. Tighten bottom screw.  
Torque: 10–11 N·m (89–97 in-lbs)
- f. Connect brake switch connector (4).
- g. Slide rubber boot (3) over connector.

6. Verify throttle function.

### NOTE

*Vehicle must not be running for this step.*

- a. Rotate throttle wide open.
- b. Release throttle.
- c. Throttle should rotate freely with no binding, dragging or slowing.

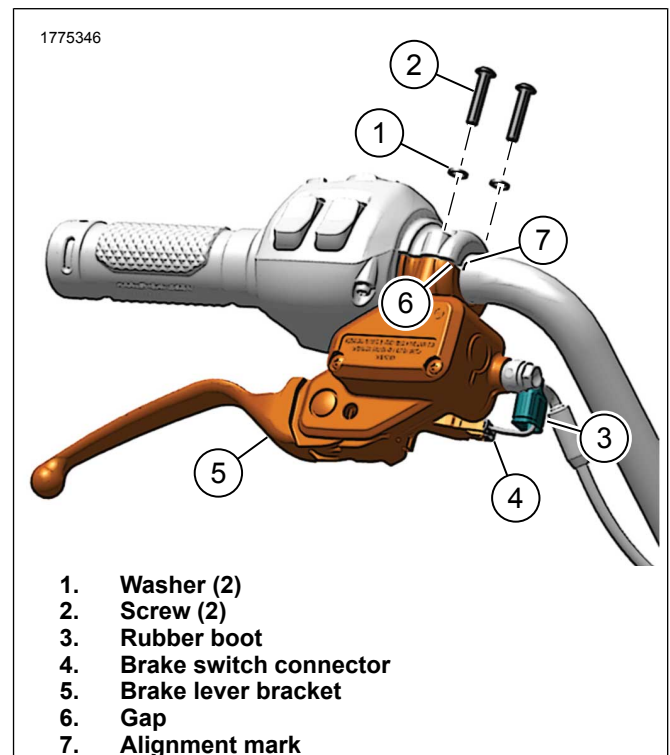

Figure 8. Brake Lever Bracket (typical)

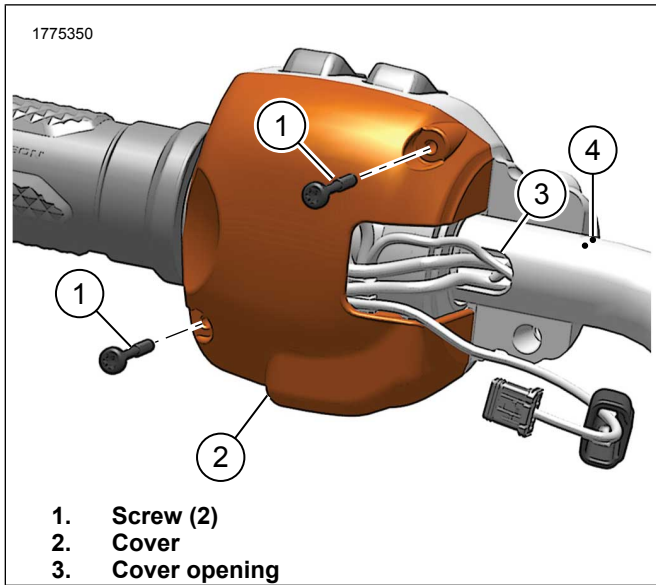

Figure 9. RHCM Cover

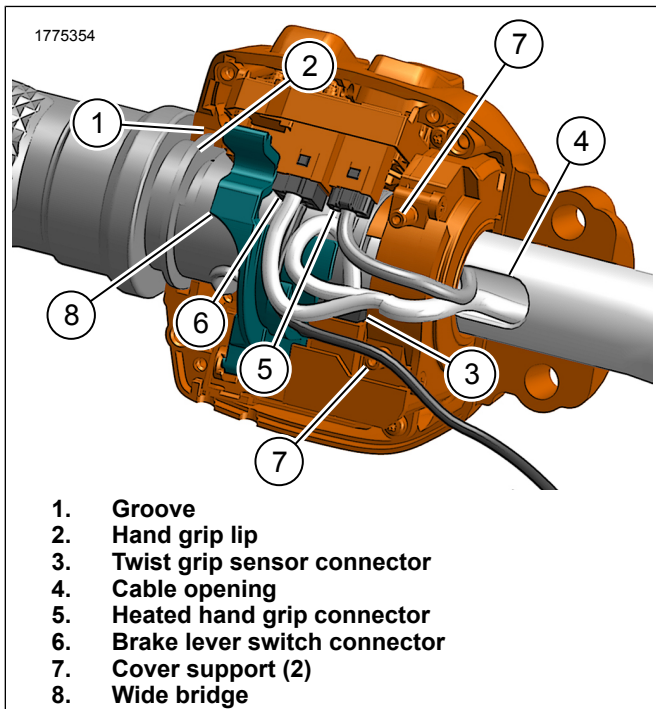

Figure 10. RHCM Connections

**NOTE**

This ridge should be pre-assembled into RHCM groove at this point when it's being slid onto the handlebar as shown in Figure 10.

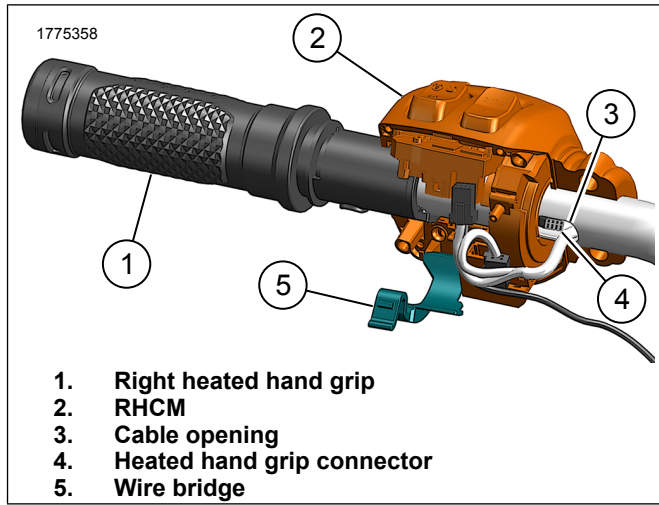

Figure 11. Right Grip Removal/Install

**COMPLETE**

1. Install main fuse. See service manual.
2. Install left side cover. See service manual.
3. Install left saddlebag. See service manual.

**NOTE**

Upon initial installation, it may take up to five minutes for the hand controls to write software updates to the heated grips. Heated grips will **NOT** function until this is complete. Do not press the Left button to turn on the grips until this occurs.

The vehicle must be running to operate the heated grips.