



INSTRUCTIONS

J06223

2023-02-28



XL QUICK RELEASE WINDSHIELD

GENERAL

Kit Numbers

57400318, 57400319

Models

For model fitment information, see the P&A retail catalog or the Parts and Accessories section of www.harley-davidson.com (English only).

⚠ WARNING

Rider and passenger safety depend upon the correct installation of this kit. If the procedure is not within your capabilities or you do not have the correct tools, have a Harley-Davidson dealer perform the installation. Improper installation of this kit could result in death or serious injury. (00308b)

Kit Contents

See Figure 2 and Table 1.

INSTALLATION

Clamp Assembly to Windshield

1. Remove the windshield sub-assembly from the packaging, and place face down on a clean, soft surface with the mount brackets facing upward.

⚠ WARNING

The cupped side of the Belleville (cone) washers must face each other and sandwich the windshield mount brackets at each mount point. Failure to orient washers correctly can reduce windshield's ability to break away in a collision, which could result in death or serious injury. (00422b)

2. See Figure 1. Loosely install clamp assemblies to the windshield mount brackets (2). Secure with shoulder bolt (1), Belleville washers (4) and cup washer (3) as shown.

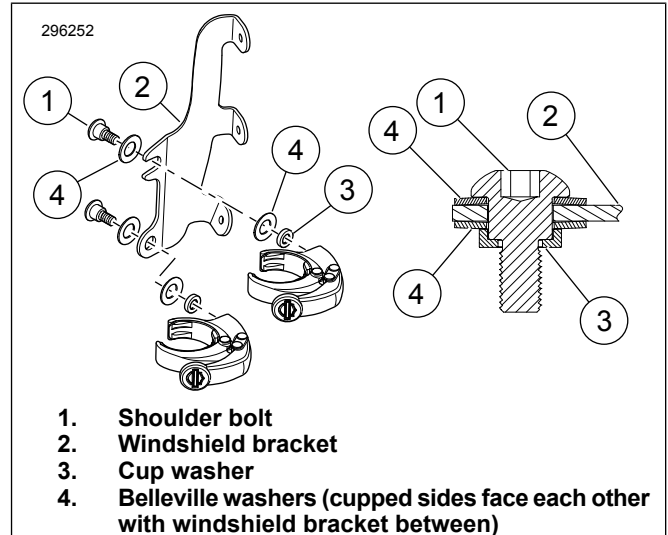

Figure 1. Windshield Mounting Clamp

3. With the clamp facing upward and outboard of the windshield bracket (2), tighten the shoulder bolts (1) enough to hold the clamps in place. The bolts will be fully tightened later.

Windshield Installation

NOTE

Keep the front wheel straight to prevent the brackets from scratching the fuel tank.

1. Make sure that all four clamps are in the "open" position.

NOTE

The polycarbonate windshield is fairly flexible and can be bent to spread the clamps away from the headlamp to ease installation to the motorcycle.

Do not scratch the headlamp housing with the clamps while positioning the windshield to the fork tubes.

⚠ WARNING

Pinched throttle cables can restrict throttle response, which could result in loss of control and death or serious injury. (00423b)

2. Position throttle cables between the windshield clamp mounting locations.
3. Center the windshield around the headlamp, and seat the clamps onto the fork tubes.

▲ WARNING

Be sure that steering is smooth and free without interference. Interference with steering could result in loss of vehicle control and death or serious injury. (00371a)

- See Figure 2. Snap the throttle cable clip (11) around the right side fork tube, and route the throttle cables through the guide opening.
- Cables should not catch on headlamp hardware or pass in front of headlamp.
 - Cables should not catch on turn signal mounting hardware or turn signals.
 - Cables should not catch on fuel cap or fuel gauge.
 - Cables should not catch on speedometer or tachometer.
 - Make sure cables are not pinched between the frame and/or forks.
 - Make sure clutch cables do not pull tight when handlebars are turned fully to the left or right fork stops.
- With the shoulder bolts still loosely threaded and starting at the bottom, close one clamp at a time over the fork tubes, noting that the clamps self-align to the tubes and to each other.

NOTE

Do not tighten the shoulder bolts beyond the recommended torque. Over-tightening may cause the clamp to twist on the fork tube, leading to insufficient grip which could cause the windshield to come loose during use.

- Make sure that the shoulders of the bolts are fully seated in each windshield bracket location. Tighten.
Torque: 5.4–8.1 N·m (48–72 **in-lbs**) *Hex socket head bolt*
- Turn the handlebars fully to the left and right fork stops to confirm that the throttle cables move freely. If interference occurs, adjust the windshield as needed until proper clearance is obtained.

NOTE

Have an experienced Harley-Davidson technician correct any problems before riding with this accessory installed.

Windshield Removal and Storage

To remove the windshield, open the four clamps and reverse the installation procedures found in **Windshield Installation**.

Take care to avoid scratching the headlamp housing or fuel tank as noted during installation.

Store the windshield in a location where the windshield clamps will receive the greatest protection. Keep from locations where the windshield may be bumped or dropped. Do not stack anything on top of the windshield assembly.

Before installation after storage, inspect the clamps and hardware for fastener preload and cleanliness. Clamps should cycle open and closed freely, and each clamp should have a pair of rubber gaskets (see Table 1) in the clamp saddle where it contacts the fork tube.

CARE AND CLEANING

Check the windshield mounting hardware periodically. Never ride with loose mounts. A loose mount causes extra stress on the remaining mounts, as well as the windshield itself, and could result in premature failure of components.

NOTICE

Polycarbonate windshields/wind deflectors require proper attention and care to maintain. Failure to maintain polycarbonate properly can result in damage to the windshield/wind deflector. (00483e)

- Sunlight reflections off of the inside curvature of a windshield can, at certain times of the day, cause extreme heat build-up on motorcycle instruments. Exercise care in parking. Park facing the sun, place an opaque object over the instruments, or adjust the windshield to avoid reflections.
- Do not clean in hot sun or high temperature.
- Powdered, abrasive or alkaline cleanser will damage the windshield.
- Never scrape the windshield with a razor blade or other sharp instrument, as permanent damage will result.

NOTICE

Use only Harley-Davidson recommended products on Harley-Davidson windshields. Do not use harsh chemicals or rain sheeting products, which can cause windshield surface damage, such as dulling or hazing. (00231c)

- Do not use benzine, paint thinner, gasoline, lubricants (including Armorall®), or other cleaning agents on the rubber bushings. Doing so will damage the bushing surfaces.

NOTE

Covering the windshield with a clean, wet cloth for about 15 minutes before washing will make dried bug removal easier.

SERVICE PARTS

1581821

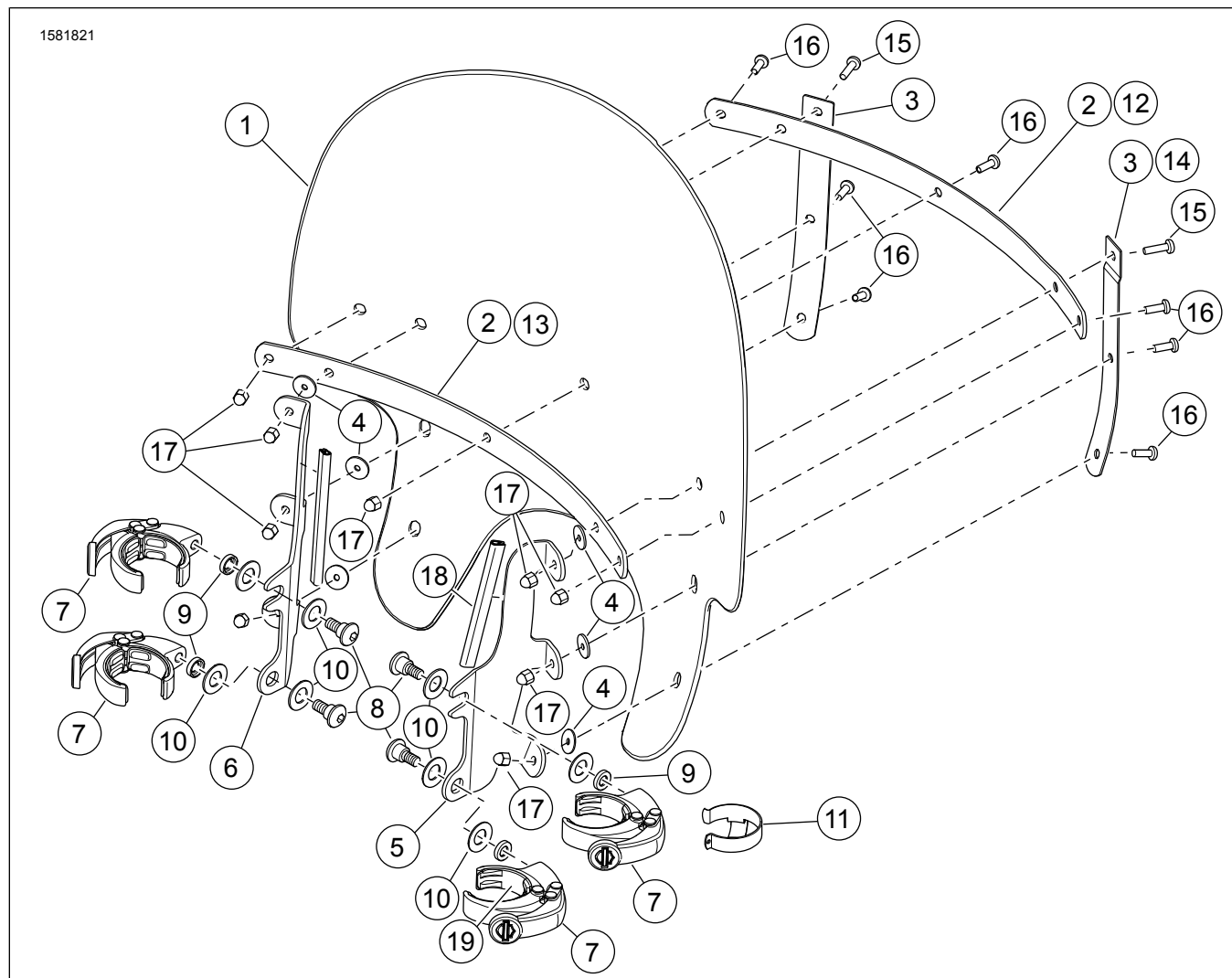

Figure 2. Service Parts: XL Quick Release Windshield

Table 1. Service Parts

Item	Description (Quantity)	Part Number
1	Windshield	Not Sold Separately
2	Tape, horizontal (2)	58052-78
3	Tape, vertical (2)	58415-08
4	Washer, black rubber (6)	58152-96
5	Bracket, windshield mount, black (right)	57300068
6	Bracket, windshield mount, black (left)	57300069
7	Quick clamp assembly, 49 mm (4)	57400468
	Hardware kit, windshield mount (includes items 8 through 11)	57300071
8	• Shoulder bolt	Not sold separately
9	• Spacer, cup washer	Not sold separately
10	• Belleville washer (2)	Not sold separately
11	• Clip, throttle cable	10800107
12	Brace, horizontal, outer (black)	58069-09
13	Brace, horizontal, inner (black)	58068-09
14	Brace, vertical (black) (2)	Not sold separately
15	Screw, button head, TORX®, #12-24 x 13/16 in. (20.6 mm) long, with lock patch (2)	2452
16	Screw, button head, TORX, #12-24 x 5/8 in. (15.9 mm) long, with lock patch (7)	2921A
17	Acorn nut, #12-24 (chrome) (9)	7651A
18	Edge protection (2)	62540-83
19	Gasket, clamp (2)	57299-07