



INSTRUCTIONS

J04757

2016-08-22



H-D DETACHABLES TOURING SOLO TOUR-PAK RACK

GENERAL

Kit Number

53260-09B

Models

For model fitment information, see the P&A retail catalog or the Parts and Accessories section of www.harley-davidson.com (English only).

Installation Requirements

Separate purchase of extra parts or accessories may be required for proper installation of this kit on your model motorcycle. See the P&A retail catalog or the Parts and Accessories section of www.harley-davidson.com (English only) for a list of required parts or accessories.

⚠ WARNING

Rider and passenger safety depend upon the correct installation of this kit. If the procedure is not within your capabilities or you do not have the correct tools, have a Harley-Davidson dealer perform the installation. Improper installation of this kit could result in death or serious injury. (00308b)

⚠ WARNING

Do not exceed Tour-Pak weight capacity. Too much weight can cause loss of control, which could result in death or serious injury. (00401c)

NOTE

See label inside Tour-Pak, operator's manual, Tour-Pak installation instructions for weight capacity limits.

Maximum Tour-Pak **luggage rack** weight capacity is 10 pounds (4.5 Kg).

Kit Contents

Figure 3 and Table 1

INSTALLATION

Tour-Pak Installation to Rack

1. Open the Tour-Pak lid and, if necessary, remove all items from inside the Tour-Pak. **Models with rubber mat:** Remove the mat. **Models with molded liner:** Open the map pocket. Remove the acorn nuts with flat washers. Remove the map pocket and liner. **ALL models:** Close the lid.

NOTE

Figure 1 When installing the Tour-Pak to the rack in the following steps, note holes in the Tour-Pak mounting plate

- (1) provide forward (3) and rearward (2) positions for mounting the Tour-Pak.

2. Place the Tour-Pak on the Tour-Pak rack, and open the lid. Align the forward or rearward holes in the Tour-Pak mounting plate with the holes in the rack.

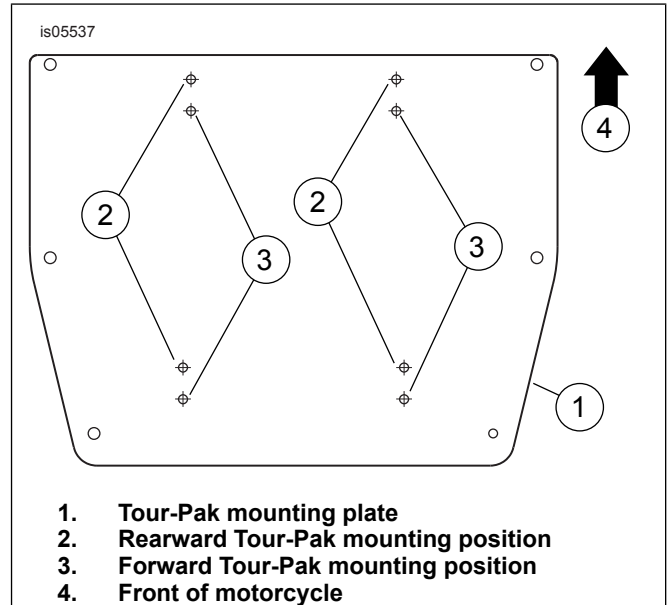

Figure 1. Tour-Pak Mounting Plate

3. Figure 3 Obtain the hex head cap screws (10), locknuts (12) and plain washers (11) from the kit. Place a washer over the threads of each screw. Insert the screw threads down through the Tour-Pak mounting plate and floor, and into the holes in the rack.

NOTE

Always install the mounting screws from inside the Tour-Pak to avoid damaging the Tour-Pak contents.

4. From the underside of the rack, install a washer and locknut onto the threads of each screw. In a crosswise pattern, alternately tighten each screw to 13.5 N·m (120 in-lbs).
5. Install the rubber mat or molded liner into the Tour-Pak. Close and latch the Tour-Pak lid.
6. Install the H-D Detachables Docking Hardware Kit to the vehicle per the instructions in that kit.

Rack Installation to Docking Points

NOTE

The Solo Detachable Tour-Pak Rack can be installed on either a **two-point** or **four-point** Docking Kit.



1. Figure 3 **Mounting to TWO-POINT docking plate:** Stand behind the motorcycle. Place the left side and right side front Tour-Pak rack notches (B, with bushings in place) onto the docking points inboard of the upper shock absorber mounts. Make sure the notch bushings (9) seat fully into the shock absorber docking points. **Mounting to FOUR-POINT docking plate:** Stand behind the motorcycle. Place the left side and right side front Tour-Pak rack notches (B, with bushings in place) onto the front docking points on the docking plates (D). Make sure the notch bushings (9) seat fully into the front docking points.
2. **ALL installations:** Figure 3 arrow (E) and Figure 2 Position the rotary latches (4) over the rear docking points (3). Check the rack sides (1) and latches fit into the neck (7) of the rear docking points as shown. This may require some gentle squeezing or spreading of the rack sides.
3. Push the rear of the rack downward. Close the latches by pressing the latch lever as far forward as it will go. You hear a "CLICK" when the latch is in place. If the latch does not easily close, do not force. Check the rack alignment again, as described earlier in this section.

NOTE

After installing the Tour-Pak rack, check to verify the Tour-Pak and rack are secure. The front and rear docking points must be fully engaged. For correct engagement, Figure 2

4. **To remove the Tour-Pak and rack,** press the release button (G) on each side. Pull the latch levers back. Carefully lift the rear of the Tour-Pak rack up. Pull the rack out of the front docking points.

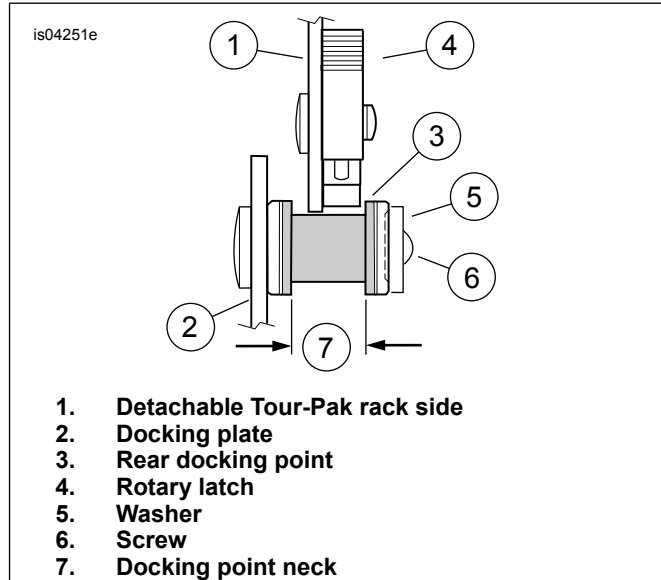

Figure 2. Proper Alignment of Latch in Rear Docking Point, View in Direction of Arrow (E)

SERVICE PARTS

Table 1. Service Parts

Item	Description (Quantity)	Part Number
1	Detachable solo Tour-Pak rack assembly (includes items 2- 4)	Not sold separately
2	• Rack weldment	Not sold separately
3	• Pivot stud (2)	Not sold separately
4	• Rotary latch kit (2)	50300108
5	• Rotary latch assembly	Not sold separately
6	• Wave washer	6828
7	• Flat washer, stainless steel	6827
8	• Screw, button head	2957
9	Bushing (2)	52682-09
10	Hex head cap screw (4)	3802W
11	Flat washer (8)	6703
12	Hex lock nut (4)	7887
Items mentioned in text, but not included in kit:		
A	Mounting locations for Tour-Pak luggage	
B	Front Tour-Pak rack notch (2)	
C	Rear Tour-Pak rack notch (2)	
D	Four-point docking plate assembly (2)	
E	To front of vehicle (view direction for Figure 2)	
F	Two-point docking plate assembly (2)	
G	Rotary latch release button (2)	

