



# INSTRUCTIONS

J06460

2017-01-16



## MILWAUKEE-EIGHT - SCREAMIN' EAGLE BLACK AIR CLEANER COVER KIT

### GENERAL

#### Kit Number

61300828

#### Models

For model fitment information, see P&A Retail Catalog or the Parts and Accessories section of [www.harley-davidson.com](http://www.harley-davidson.com) (English only).

#### Installation Requirements

This kit requires the separate purchase of Loctite® 243 Medium Strength Threadlocker and Sealant - Blue (Part Number 99642-97)

#### ⚠ WARNING

Rider and passenger safety depend upon the correct installation of this kit. If the procedure is not within your capabilities or you do not have the correct tools, have a Harley-Davidson dealer perform the installation. Improper installation of this kit could result in death or serious injury. (00308b)

#### Kit Contents

See Figure 1 and Table 1.

### REMOVAL

1. Remove main fuse. See the owners manual.
2. Remove air cleaner cover. See the owners manual.

### INSTALLATION

#### Install Air Cleaner Cover and Insert.

##### NOTE

Whenever the air cleaner cover is installed, apply Loctite 243 (blue) to the air cleaner cover screw.

1. Carefully remove the original air cleaner cover insert from air cleaner cover. Discard OE cover.

2.

##### NOTE

- Ambient temperature should be between 21–38 °C (70–100 °F) for proper adhesion. Do not apply below 10 °C (50.0 °F).
- Parts cannot be repositioned after initial adhesive installation.

- Allow **at least 24 hours** after application before exposing the area to vigorous washing, strong water spray or extreme weather.
- The adhesive bond will increase to maximum strength after about 72 hours at normal room temperature.
- Do not clean with denatured alcohol, mineral spirits or other solvents. Damage to components may occur.

Using a 50:50 isopropyl alcohol/water solution, thoroughly clean cover insert surfaces. Allow to dry completely.

3. Install cover insert on to area.
  - a. With the adhesive backing still in place, test fit the cover insert to the area.
  - b. Remove the adhesive backing.
  - c. Install the cover insert to the area.
  - d. Press surface of the air cleaner cover insert firmly to make sure that there is good adhesion. After releasing pressure, avoid direct contact with the insert for about 20 minutes.
4. Assemble the air cleaner cover. Tighten screws to 4.5–6.8 N·m (40–60 in-lbs).

### Final Assembly

1. Install main fuse.

### Service Parts

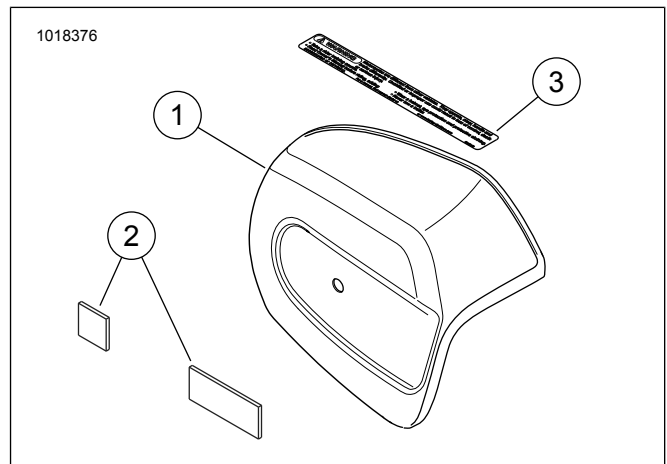

Figure 1. Screamin' Eagle Air Cleaner Cover Kit



**Table 1. Service Parts Table**

| <b>Item</b> | <b>Description (Quantity)</b> | <b>Part Number</b>  |
|-------------|-------------------------------|---------------------|
| 1           | A-C cover, black              | Not Sold Separately |
| 2           | Air cleaner cover adhesives   | Not Sold Separately |
| 3           | Label, warning                | 29108-08            |