



# INSTRUCTIONS

J06222

2015-04-29



## BACKREST PAD KIT

### GENERAL

#### Kit Number

52300364, 52300366

#### Models

For model fitment information, see the P&A Retail Catalog or the Parts and Accessories section of [www.harley-davidson.com](http://www.harley-davidson.com) (English only).

#### Kit Contents

See Figure 1 and Table 1.

#### ⚠ WARNING

Rider and passenger safety depend upon the correct installation of this kit. If the procedure is not within your capabilities or you do not have the correct tools, have a Harley-Davidson dealer perform the installation. Improper installation of this kit could result in death or serious injury. (00308b)

### INSTALLATION

1. With your hand, feel through the backrest material to locate the mounting holes.
2. Carefully cut the clear plastic rain seal away from the screw holes in the backrest pad to prevent the plastic from catching in the screw threads.
3. See Figure 1. Secure the backrest to the sissy bar upright using the screws from the kit.
4. Tighten the screws to 4–7 N·m (35–60 in-lbs).

### SERVICE PARTS

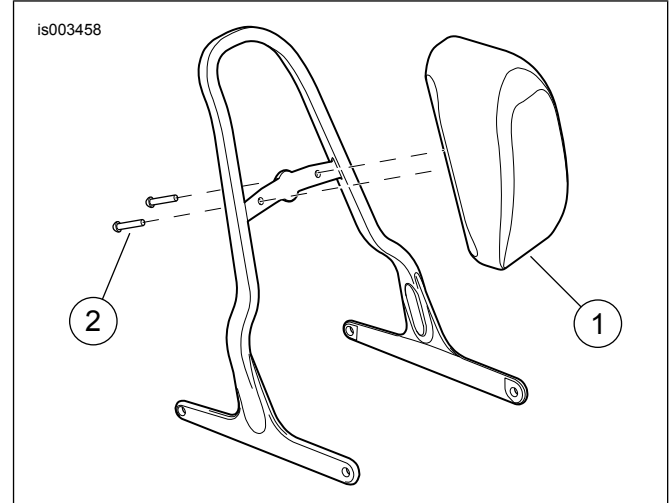

Figure 1. Service Parts: Backrest Pad Kit

Table 1. Service Parts

Item	Description (Quantity)	Part Number
1	Backrest pad	Not Sold Separately
2	Screw, Button head (2)	94386-92T