



INSTRUCTIONS

J06266

2022-06-21



SPECTRA GLO LED R/G/B CONTROLLER

GENERAL

Kit Numbers

68000218

Models

For model fitment information, see the P&A retail catalog or the Parts and Accessories section of www.harley-davidson.com (English only).

NOTE

Retain this instruction sheet for future installation and operation of other R/G/B lighting kits.

Kit Contents

⚠ WARNING



Contains button or coin cell battery. Hazardous if swallowed, can result in death or serious injury. (13807a)

INSTALLATION REQUIREMENTS

Separate purchase of Power Connection Kit (Part No. 69201526 or 69201636), unless already installed.

When other accessories are installed to the main harness, an optional Switched Circuit Adapter Harness (part number 69201706) should be used in conjunction with this kit.

⚠ WARNING

Rider and passenger safety depend upon the correct installation of this kit. If the procedure is not within your capabilities or you do not have the correct tools, have a Harley-Davidson dealer perform the installation. Improper installation of this kit could result in death or serious injury. (00308b)

NOTE

This controller kit is designed to operate the various Spectra Glo LED light kits.

All Spectra Glo LED light kits are designed and intended for display use only. Some local regulations prohibit using colored or indirect lighting during vehicle operation on public streets. Check local regulations before installation.

Electrical Overload

NOTICE

It is possible to overload the vehicle's charging system by adding too many electrical accessories. If the combined electrical accessories operating at any one time consume more electrical current than the vehicle's charging system can produce, the electrical consumption can discharge the battery and cause damage to the vehicle's electrical system. (00211d)

⚠ WARNING

When installing any electrical accessory, be certain not to exceed the maximum amperage rating of the fuse or circuit breaker protecting the affected circuit being modified. Exceeding the maximum amperage can lead to electrical failures, which could result in death or serious injury. (00310a)

Refer to SPECTRA GLO LOAD CALCULATION INFORMATION section later in this document for more information.

KIT CONTENTS

Figure 2 and Table 1.

FCC REGULATIONS

FCC ID: M3N68000217

This device complies with Part 15 of the FCC Rules and with Industry Canada licence-exempt RSS standard(s). Operation is subject to the following two conditions: (1) this device may not cause harmful interference, and (2) this device must accept any interference received, including interference that may cause undesired operation.

NOTE

Changes or modifications made to this equipment not expressly approved by Continental may void the FCC authorization to operate this equipment.

This equipment has been tested and found to comply with the limits for a Class B digital device, pursuant to Part 15 of the FCC Rules. These limits are designed to provide reasonable protection against harmful interference in a residential installation. This equipment generates, uses and can radiate radio frequency energy and, if not installed and used in accordance with the instructions, may cause harmful interference to radio communications. However, there is no guarantee that interference will not occur in a particular installation. If this equipment does cause harmful interference to radio or television reception, which can be determined by turning the equipment off and on, the user is encouraged to try to correct the interference by one or more of the following measures:



- Reorient or relocate the receiving antenna.
- Increase the separation between the equipment and receiver.

- Connect the equipment into an outlet on a circuit different from that to which the receiver is connected.

- Consult the dealer or an experienced radio or TV technician for help.

RGB LIGHT HARNESS LOCATION (Common Light Combinations)

1010087

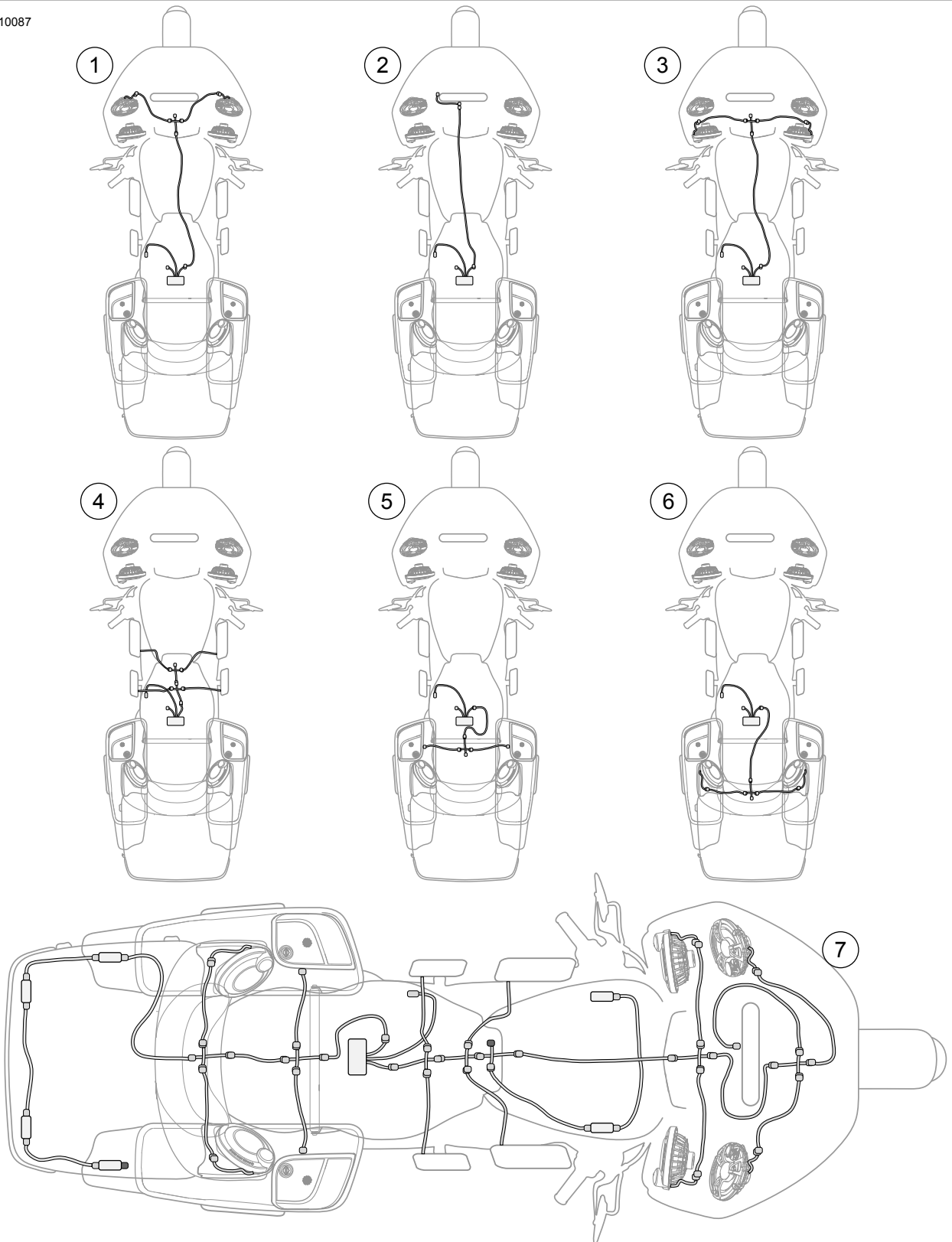

- 1. Upper Speaker R/G/B Lights and Controller
- 2. Vent R/G/B Light and Controller
- 3. Lower Speaker R/G/B Lights and Controller
- 4. Footboard R/G/B Lights and Controller

- 5. Saddlebag Speaker R/G/B Lights and Controller
- 6. Tour-Pak Speaker R/G/B Lights and Controller
- 7. All R/G/B Lights with Controller

Figure 1.

INSTALLATION

1. See service manual. Remove seat.

2. See service manual. Remove left side cover.

3. **NOTE**

Beginning with 2017 Touring models, a black 3-way P&A accessory connector is located under the right side cover. See the service manual for more information.

Models with accessory connector: Install Accessory Connection Kit (Part No. 69201526) unless already installed. Proceed to step 5.

4. **Models without accessory connector:** Install Accessory Connector Kit (Part No. 69201636).

5. Figure 2 Choose a suitable location for mounting the controller (5) under the seat or behind the left side cover. Use two-sided tape (3) provided in kit, or cable straps (1).

6. **NOTE**

Clean the controller mounting area with soap. Allow to dry thoroughly. Remove debris, dirt and grime from the vehicle areas to be highlighted.

Ambient temperature should be **at least** 10 °C (50.0 °F) for proper adhesion of the controller to vehicle surfaces.

Unused end of the light string must have an end cap (2) installed.

7. Connect the controller harness to the accessory power harness.

8. Bundle the wire leads from the controller. Use the cable straps (1) to secure the controller leads and all wiring between the lights.

9. See the service manual. Install left side cover.

10. See the service manual. After installing seat, pull up on the seat to verify it is secure.

SERVICE PARTS

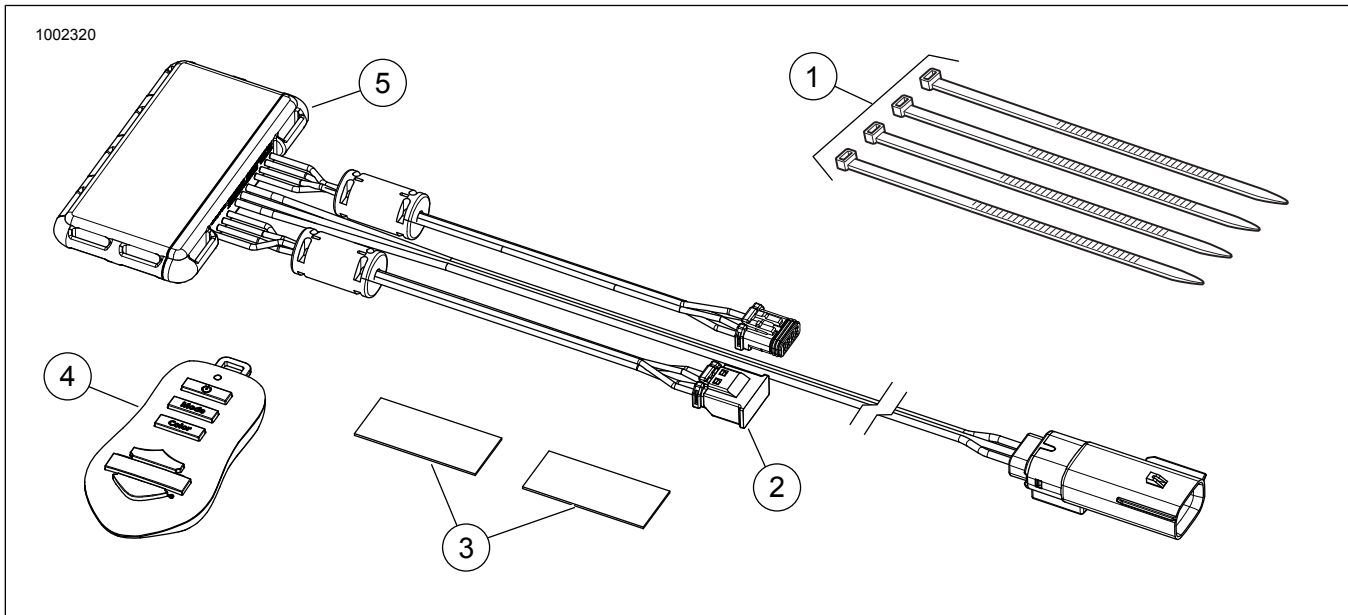

Figure 2. Service Parts, Spectra Glo Controller Kit

SERVICE PARTS

Table 1. Service Parts Table

Kit	Item	Description (Quantity)	Part Number
68000218	1	Cable strap (4)	10006
	2	End cap	69201616
	3	Tape, two-sided (2)	Not Sold Separately
	4	Fob, LED R/G/B controller	68000217
	5	Controller, LED R/G/B	68000219

SPECTRA GLO LOAD CALCULATION INFORMATION

The Spectra Glo system is limited to 3000 mA. Use the following table to determine the total current draw of the desired

configuration. Calculate the total current draw by multiplying the number of kit(s) (each line) by the provided current draw. Sum all totals. The value should be less than or equal to 3000 mA. The following example describes how to calculate total system load.

Table 2. Calculator Example of Spectra Glo Kits

Kit Name	Kit Part Number	Number of Kits	Current mA	Total
Rider Footboards	50500492	1	500	500
Passenger Footboards	50500495	1	350	350
Fairing Vent	68000194		275	
Speaker Lights (Stage I)	68000232		125	
Speaker Lights (Stage II Round)	68000231	1	125	125
Speaker Lights (Stage II Saddle Bag)	68000233		125	
Base Light Pods (6)	68000213	2	450	900
Expansion Light Pods (4)	68000214	1	300	300
* System Total must be 3000 mA or less.			System Total =	2175

Table 3. Spectra Glo RGB Accessory Calculator

Kit Name	Kit Part Number	Number of Kits	Current mA	Total
Rider Footboards	50500492		500	
Passenger Footboards	50500495		350	
Fairing Vent	68000194		275	
Speaker Lights (Stage I)	68000232		125	
Speaker Lights (Stage II Round)	68000231		125	
Speaker Lights (Stage II Saddle Bag)	68000233		125	
Base Light Pods (6)	68000213		450	
Expansion Light Pods (4)	68000214		300	
* System Total must be 3000 mA or less.			System Total =	

Table 4. Spectra Glo RGB Accessories

Accessories	Part Number
Fob	68000217
JAЕ Cap	69201597
Y Harness (3-way)	69201594
3-in Jumper Harness	69201525
8-in Jumper Harness	69201529
24-in Jumper Harness	69201530
24-in Jumper with grommet	69201595
48-in Jumper Harness	69201625

SPECTRA GLO OPERATION

Fob

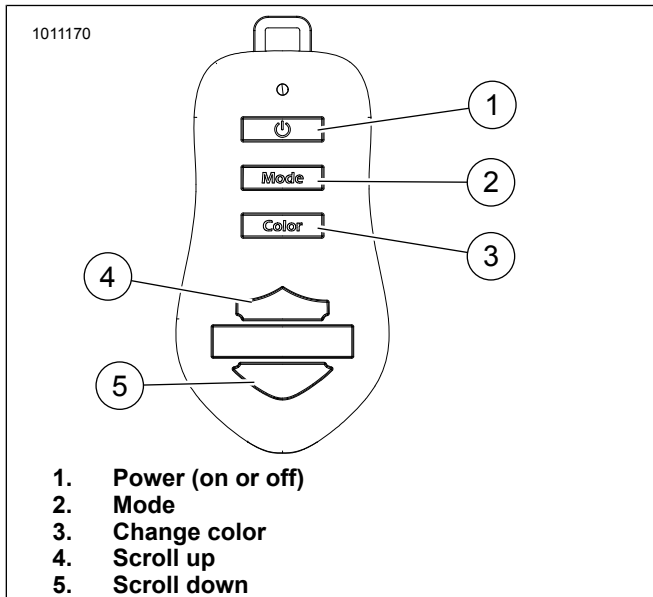

Figure 3. Fob

Default Settings

- The controller and fob arrive paired. See Fob Pairing if fob needs to be paired.
- See Figure 4. Seven preset color zones are available. Each having a number of shades:
 - White
 - Green
 - Aqua
 - Blue
 - Pink
 - Red
 - Yellow
- Three color modes are available:
 - Solid
 - Flash
 - Fade

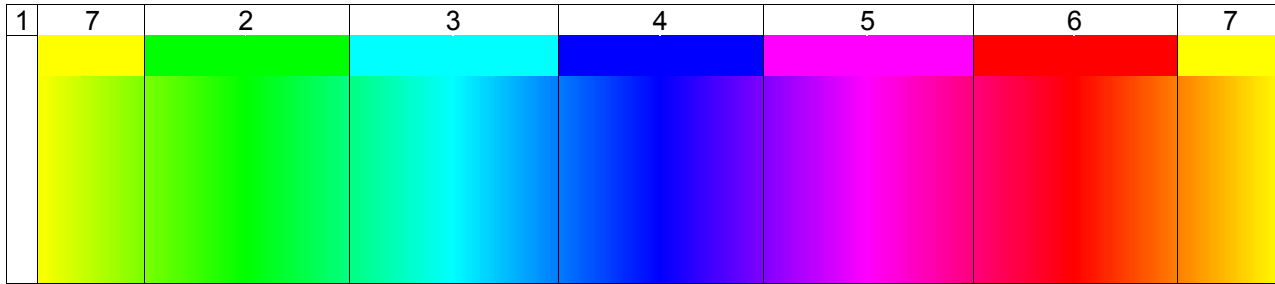

Figure 4. Color Spectrum

OPERATION

System ON/OFF

NOTE

The lights will resume its last settings when the vehicle has been powered on after being off.

1. Wake the controller from Low Power Sleep by turning the ignition switch to the Ignition or Accessory position.
2. See Figure 3. Press the Power button (1) on the fob.

Changing the Mode

1. See Figure 3. Press the Mode button (2) to toggle through the three modes.
2. Adjust the flash and fade speeds:
 - a. Set mode to Flash or Fade.
 - b. Press the Scroll up button (4) to increase the speed gradually. Hold to quickly increase speed.
 - c. Press the Scroll down button (5) to increase the speed gradually. Hold to quickly decrease speed.
3. The next time either Flash or Fade color mode resume, the previous speed selection will resume until it is changed.

Changing Color

1. See Figure 3. Press Change Color button (3) to scroll and change color zones.

2. *NOTE*

Shade cannot be adjusted in the White Color Zone.

Adjust the color shade:

- a. Set mode to Solid.
- b. Press the Scroll up (4) or Scroll down (5) button repeatedly to slowly change the shade. Hold the button to quickly change the shade.

Fob Pairing

1. *NOTE*

See Figure 5. The key ring bail (3) can fall when cover is removed. Use care not to lose it.

- See Figure 5. Remove four screws securing the back cover of fob. Remove cover.
2. Turn the ignition switch to the Ignition or Accessory position.
3. Disconnect controller power connector for 10 seconds.
4. Connect controller power connector. Pairing mode is active for only 15 seconds.
5. Press and hold button (2) until Spectra Glo lights on vehicle cycle through all seven color zones.
6. Install fob cover.

Reset Factory Default

1. Perform steps 1-4 of Fob Pairing.
2. See Figure 5. Press and hold button (2) until Spectra Glo lights on vehicle cycle through all seven color zones. Continue to hold an extra 5 seconds until Spectra Glo lights cycle through all seven color zones a second time.
3. Install fob cover.

Replace Fob Battery

1. *NOTE*

The key ring bail (3) can fall when cover is removed. Use care not to lose it.

- See Figure 5. Remove four screws hold on back cover of fob. Remove cover.
2. Remove battery (1) by pushing battery out of retainer.
3. Install new battery (CR2032 or equivalent) with positive (+) side up.
4. Install fob cover.

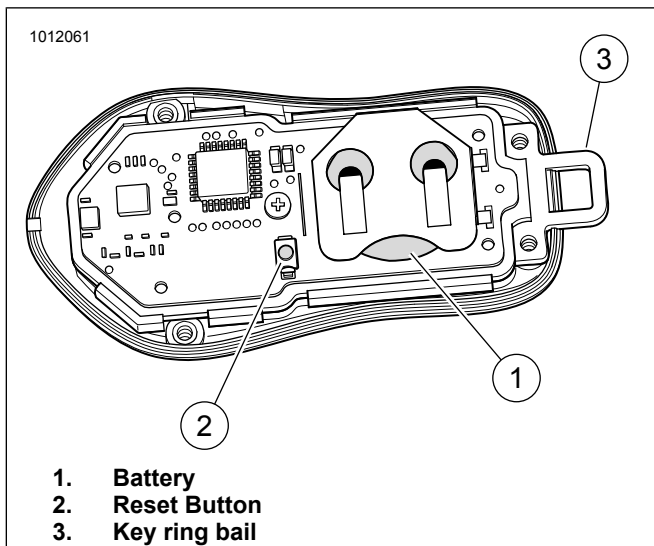

Figure 5. Fob Reset and Battery

ADDITIONAL FEATURES

1. Active Sleep

- a. Reduces battery drain while system is listening for commands from fob (system off).
- b. **This occurs** up to 60 minutes after last button command when system is off.

2. Deep Sleep

- a. System shuts down to reduce excessive battery drain while vehicle is off and system is not in use.
- b. **This occurs** when system has been in Active Sleep mode for more than 30 minutes. Either when IGN is OFF or system voltage is under 11.5 volts.

3. Engine Running Lockout

- a. For safety reasons, all buttons on fob are disabled. The mode automatically changed to solid and lights maintain current color.
- b. **This occurs** when the vehicle's switch is in the IGN (Ignition) position and engine is running or battery voltage is greater than approximately 13 volts.

4. Overcurrent or Overvoltage Shut Down

- a. System turns off to protect against overvoltage, system shorts and over loading the system.
- b. **This occurs** when system voltage exceeds 16 volts, wire harness is shorted to battery or ground or number of accessories exceed maximum system threshold (3000 mA) (refer to Load Calculation Table).

TROUBLESHOOTING

For each scenario, follow remedy steps in order. Only continue to next step if symptom has not been solved.

Table 5.

Symptom	Remedy
<ul style="list-style-type: none"> • Lights will not turn on • Fob buttons will not work 	<ol style="list-style-type: none"> 1. Confirm Power Connection Kit (Part No. 69201526 or 69201636) is properly installed. 2. Confirm that vehicle power is between 11.5-13 volts at controller connector (battery and IGN) pins while switched to IGN or ACC. <ol style="list-style-type: none"> a. If vehicle is switched to IGN or ACC and power is greater than 13 volts, system entered Engine Running Lockout mode. See Additional Features. b. If vehicle power is less than 11.8 volts, system entered Low Battery Shut Down mode. See Additional Features. 3. Confirm that fob battery does not require replacement. See Battery Replacement. 4. Perform Fob Pairing procedure. See Fob Pairing.
<ul style="list-style-type: none"> • Plugged in charger and buttons on fob will not work • Plugged in charger and lights are stuck in solid color mode • Lights set to flashing or fade mode, plugged in charger and system is set to solid mode 	<p>NOTE</p> <p>Plugging in a charger with vehicle switched to IGN or ACC can cause system to enter Engine Running Lockout mode. See Additional Features.</p> <ol style="list-style-type: none"> 1. Confirm that system power is between 11.5-13 volts at controller battery and IGN pins while switched to IGN or ACC. <ol style="list-style-type: none"> a. If system power is greater than 13 volts, lights have entered Engine Running Lockout mode. See Additional Features. b. Switch vehicle OFF and test function.
<ul style="list-style-type: none"> • Color zones do not look like colors in manual – colors look very similar 	<ol style="list-style-type: none"> 1. Start from controller and check for shorts in components or RGB wiring by disconnecting individual segments or groups of accessories.

Table 5.

Symptom	Remedy
<ul style="list-style-type: none"> • I want to turn my lights on or off while riding • I want my lights to flash while riding • I have lights in flashing or fade mode and when vehicle is started it turns to solid mode 	<ol style="list-style-type: none"> 1. While riding, lights enter Engine Running Lockout mode. See Additional Features. For safety reasons, lights must be turned on and color selected before engine is started.
<ul style="list-style-type: none"> • Vehicle is switched to IGN or ACC – lights were working but then turned off 	<ol style="list-style-type: none"> 1. Confirm that system power is between 11.5-16 volts at controller battery and IGN pins while switched to IGN or ACC. 2. If system power is greater than 16 volts, lights have entered Overcurrent or Overvoltage Shut Down mode. See Additional Features. 3. The vehicle may have entered one of the sleep modes. See Additional Features. <ol style="list-style-type: none"> a. If vehicle has been idle less than 90 minutes, it has entered Active Sleep Mode. See Additional Features. Press Power button on fob to turn lights back on. b. If vehicle has been idle for longer than 90 minutes, it has entered Deep Sleep mode. See Additional Features. Wake system by turning vehicle's switch to IGN or ACC momentarily and press Power button on fob to turn lights back on.