



INSTRUCTIONS

J04737

2018-08-21



MINI-FOOTBOARD KIT

GENERAL

Kit Numbers

50451-09, 50500109, 50500124, 50500139, 50500144, 50501148, 50501225

Models

For model fitment information, see the P&A Retail Catalog or the Parts and Accessories section of www.harley-davidson.com (English only).

Installation Requirements

Softail models require separate purchase of footpeg support kit P/N 50454-09 when used in passenger position.

Kit Contents

- For Kit 50451-09, see Figure 2. There are no service parts for this kit.
- For all except Kit 50451-09, see Figure 3. Fasteners (4) 94334-91T (chrome) and 12600031 (black) are available service parts.
- For Kit 50501148, see Figure 4 and Table 1. Fastener (2) 10500147 (chrome) are available service parts.
- For Kit 50501225, see Figure 4 and Table 1. Fastener (2) 10500125 (black) are available service parts.

⚠ WARNING

Rider and passenger safety depend upon the correct installation of this kit. If the procedure is not within your capabilities or you do not have the correct tools, have a Harley-Davidson dealer perform the installation. Improper installation of this kit could result in death or serious injury. (00308b)

⚠ WARNING

Footrests must fold up and toward rear of motorcycle if struck. Failure to set footrests to fold up and back could result in death or serious injury. (00366a)

INSTALLATION

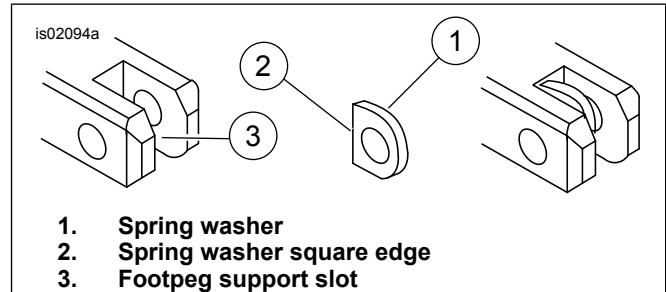

Figure 1. Footpeg Spring Washer Installation

1. Remove the locknuts and screws that hold the existing footpegs in place. If the motorcycle is equipped with a pin and retaining ring, remove them and retain for future use. Save all hardware for installation of the new footpegs.
2. Remove the existing footpegs and the spring washers. Save the spring washers for installation.
3. See footpeg support installation instructions for Softail models when used in passenger position.

NOTE

See Figure 1. When performing the next step, verify that the spring washer is positioned inside of the footpeg support with the square edge (2) towards the inside of the support.

4. Install the new footpegs in the same manner as the old footpegs were installed. Insert a spring washer (1) and the mount end of the footpeg inside the slots (3) of the footpeg supports.
5. Secure each footpeg and spring washer with the screw and locknut or pin and retaining ring removed earlier. Tighten.

Torque: 26 N·m (19 ft-lbs) Locknuts

NOTE

When rotating and adjusting the footboard for comfort, additional considerations should be made so that the footboard does not interfere with other components in the folded up position.

Verify that the footboard will fold up and back.

6. To adjust the footboard for comfort: 50451-09 kit, see Figure 2.
 - a. Remove the adjustment screw (4).
 - b. Partially remove the tread assembly (1, 2, 3) from the support shaft (5).

- c. Rotate the tread assembly around the support shaft. Teeth on the shaft will engage the internal nut (3) every 10 degrees.
- d. Fully seat the tread assembly back on the support shaft.
- e. Install the adjustment screw. Tighten.
Torque: 29 N·m (21 ft·lbs) *Adjusting screw*

7. **To adjust the footboard for comfort: all except 50451-09 kit, see Figure 3.**

- a. Remove the adjustment screw (4).
- b. Partially remove the tread assembly (1 and 3) from the support shaft (2).
- c. Rotate the tread assembly around the support shaft. Teeth on the shaft will engage teeth in the base every 10 degrees.
- d. Fully seat the tread assembly back on the support shaft.
- e. Install the adjustment screw. Tighten.
Torque: 29 N·m (21 ft·lbs) *Adjusting screw*

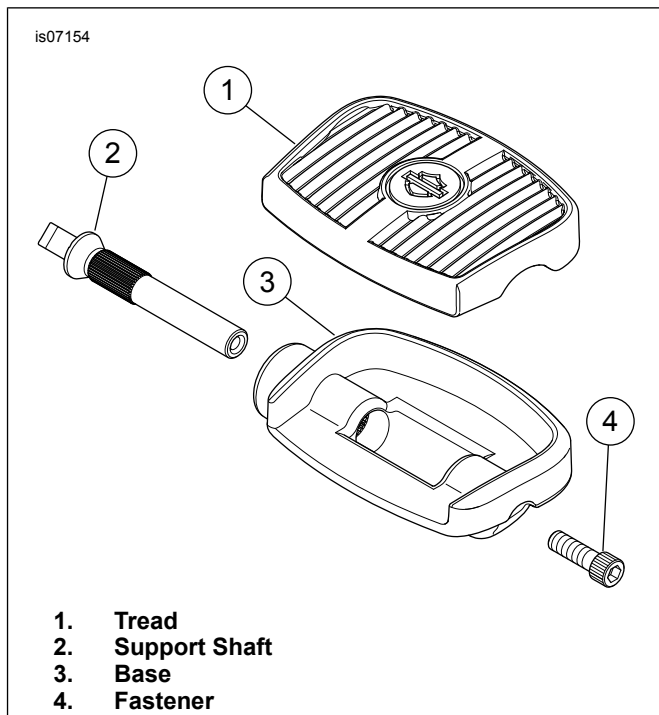

Figure 3. Mini-Footboard Kit: All Except 50451-09, 50501148, 50501225

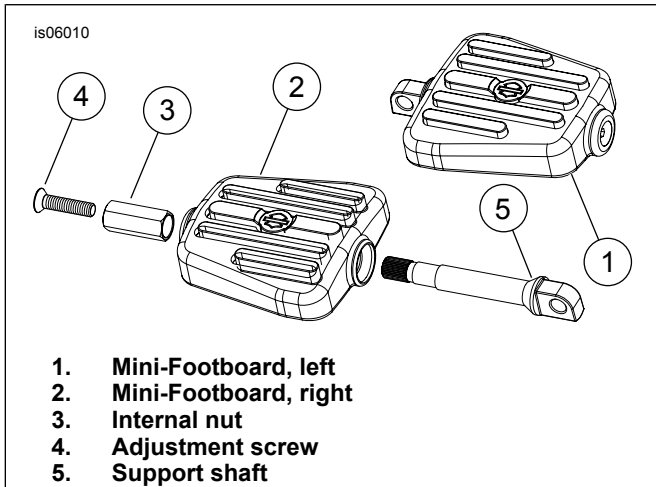

Figure 2. Mini-Footboard Kit: 50451-09

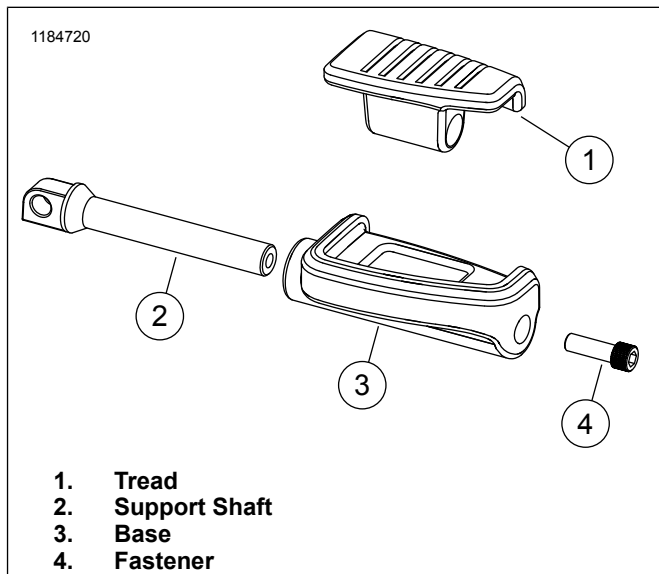

Figure 4. Mini-Footboard Kits: 50501148, 50501225

Table 1. Service Parts

Kit	Item	Description Quantity)	Part Number
50501148 Chrome	1	Tread, left side	50501181
		Tread, right side	50501184
	2	Shaft	50351-03
	3	Base, left side	50501189
		Base, right side	50501191
4	Screw, chrome	10500147	
50501225 Black	1	Tread, left side	50501181
		Tread, right side	50501184
	2	Shaft	51428-09
	3	Base, left side	50501190
		Base, right side	50501192
4	Screw, black	10500125	