



INSTRUCTIONS

J04760

2008-11-20



DETACHABLE DOCKING HARDWARE KIT

GENERAL

Kit Numbers

54030-09, 54249-09

Models

For model fitment information, see the P&A Retail Catalog or the Parts and Accessories section of www.harley-davidson.com (English only).

Additional Parts Required

Separate purchase and installation of additional parts or accessories may be required for proper installation of this kit on your model motorcycle. Please see the P&A Retail Catalog or the Parts and Accessories section of www.harley-davidson.com (English only) for a list of required parts or accessories for your model.

Tools and Supplies Required

Loctite® 262 Threadlocker and Sealant - Red (99759-99) is required for proper installation of this kit.

⚠ WARNING

Rider and passenger safety depend upon the correct installation of this kit. If the procedure is not within your capabilities or you do not have the correct tools, have a Harley-Davidson dealer perform the installation. Improper installation of this kit could result in death or serious injury. (00308b)

Kit Contents

See Figure 2 and Table 1.

INSTALLATION

1. See Figure 2 and Table 1. Apply 2 or 3 drops of Loctite® 262 (red) to the TORX® screws (4). Install docking plates (1 and 2) to fender cover and fender rail (A) with washers (3) and TORX screws (4) and tighten to 23 N·m (17 ft-lbs).
2. See Figure 1. The docking point must be attached to the docking plate (2) with the chamfer (1) facing the plate and the flat side facing out.

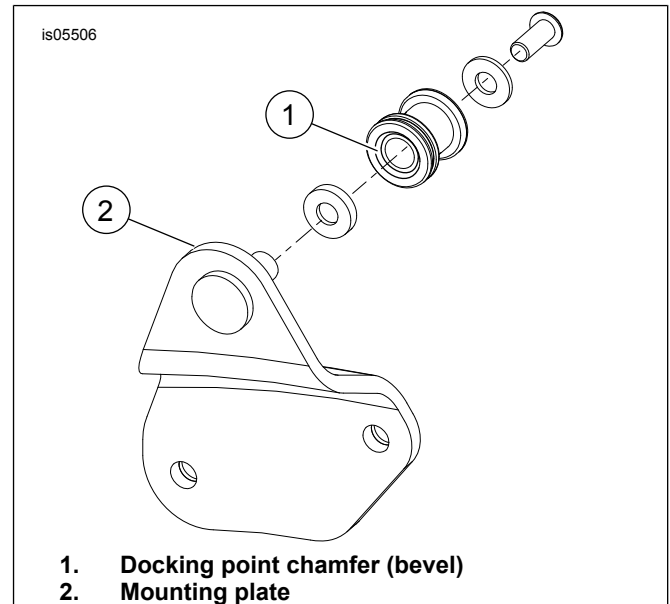

Figure 1. Docking Point Installation

3. See Figure 2 and Table 1. Install the docking points (7) to the docking plates (1 and 2) using washers (5 and 8) and screw (6). Tighten to 14.2 N·m (10.5 ft-lbs).

SERVICE PARTS

is05505

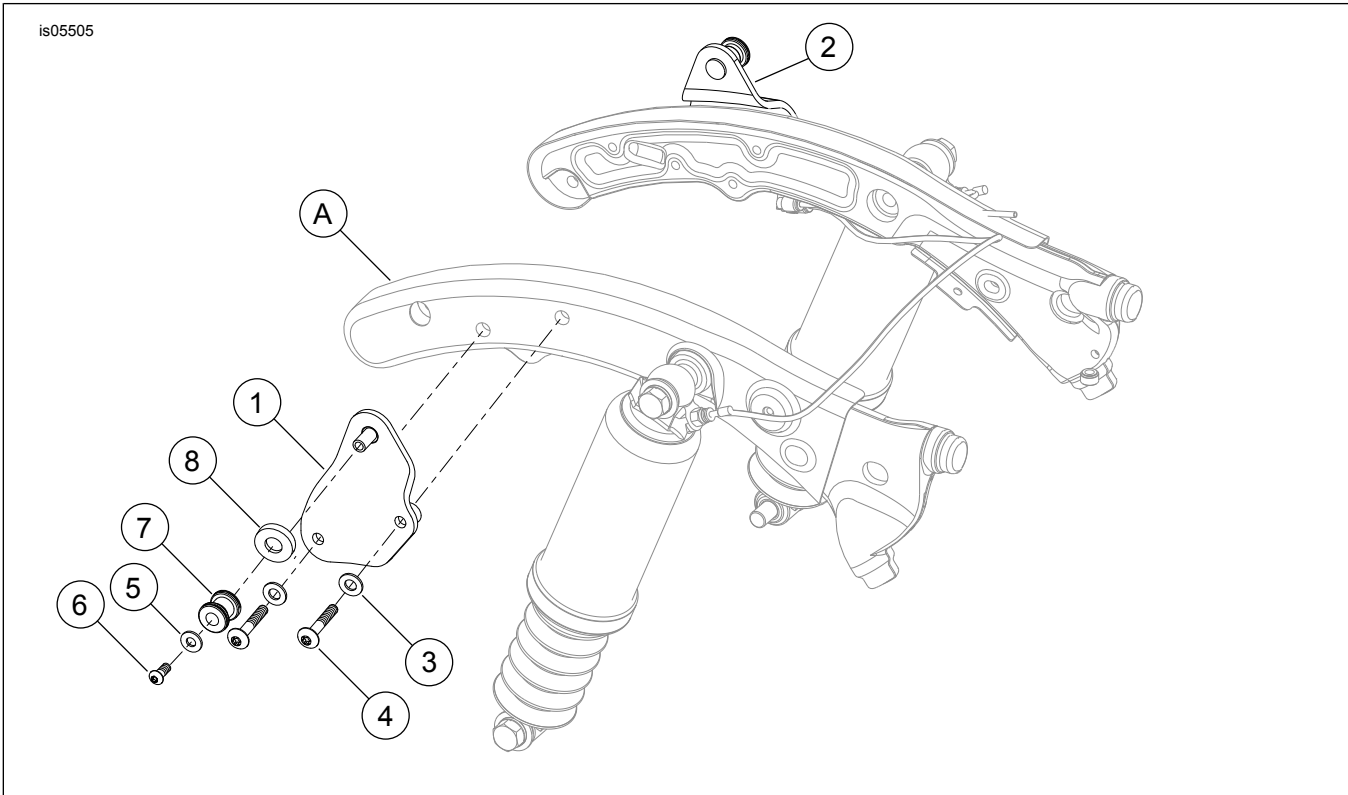

Figure 2. Service Parts: Detachable Docking Hardware Kit

Table 1. Service Parts Table

Item	Description (Quantity)	Part Number
1	Docking plate, chrome right side	54042-09
	Docking plate, gloss black right side	54274-09
2	Docking plate, chrome left side	54040-09
	Docking plate, gloss black left side	54275-09
3	Plain washer, type A (4)	6330
4	Button head TORX® screw, 5/16-18 (4)	4783
5	Plain washer, type A (2)	6339
6	Button head screw, 1/4-20 x 3/4 inch (2)	4349
7	Docking point (2)	53684-96A
8	Washer (2)	94067-90T
Items mentioned in text, but not included in kit:		
A	Frame rail and cover	