



INSTRUCTIONS

J05031

2017-08-23



HEAVY BREATHER AIR CLEANER DECORATIVE COVERS

GENERAL

Kit Numbers

28741-10, 28742-10, 28740-10A, 28739-10A

Models

For model fitment information, see the P&A Retail Catalog or the Parts and Accessories section of www.harley-davidson.com (English only).

Additional Parts Required

A Heavy Breather air cleaner kit must be purchased separately. See a Harley-Davidson dealer.

Separate purchase of Loctite® 243 Threadlocker and Sealant - Blue (part no. 99642-97) is required for installation of this kit.

⚠ WARNING

Rider and passenger safety depend upon the correct installation of this kit. If the procedure is not within your capabilities or you do not have the correct tools, have a Harley-Davidson dealer perform the installation. Improper installation of this kit could result in death or serious injury. (00308b)

NOTE

This instruction sheet references service manual information. A service manual for your model motorcycle is required for this installation and is available from a Harley-Davidson dealer.

Kit Contents

See Figure 1 and Table 1.

INSTALLATION

Remove

⚠ WARNING

Disconnect negative (-) battery cable first. If positive (+) cable should contact ground with negative (-) cable connected, the resulting sparks can cause a battery explosion, which could result in death or serious injury. (00049a)

⚠ WARNING

To prevent accidental vehicle start-up, which could cause death or serious injury, disconnect battery cables (negative (-) cable first) before proceeding. (00307a)

1. Refer to the service manual to remove the seat.
2. Disconnect the battery cables, negative cable first.

NOTE

Chrome end plates on the air filter are secured on with adhesive and are not removable. Any additional decorative end caps must be removed to allow this kit to fit properly.

⚠ WARNING

When servicing the fuel system, do not smoke or allow open flame or sparks in the vicinity. Gasoline is extremely flammable and highly explosive, which could result in death or serious injury. (00330a)

3. See Figure 1. Loosen the band clamp (A) and pull the air filter (B) off of the intake tube (C).

⚠ WARNING

Do not use gasoline or solvents to clean filter element. Flammable cleaning agents can cause an intake system fire, which could result in death or serious injury. (00101a)

4. Replace the filter element if damaged or if filter media cannot be adequately cleaned.
5. Clean and oil the filter element according to the instructions included with the air cleaner kit or, if stock, according to the service manual.

Install

1. See Figure 1. Remove the adhesive backing and place the foam circle (4) inside of the small end of the decorative cover.
2. With the filter element removed and cleaned, place the decorative cover (1) over the filter element (B). The band clamp cover (D) must be in place to make sure the decorative cover fits properly.

NOTE

The opening in the band clamp cover (which provides access to the hose clamp screw) will be facing the engine.

When servicing the air cleaner cover, apply Loctite 243 to all threaded fasteners.

3. Place the mounting ring (2) over the band clamp cover (D). Apply Loctite 243 to the four screws (3). Loosely insert the four screws. Position the decorative cover to the desired orientation. Tighten the four screws to:

Torque: 1.7 N·m (15 in-lbs) cover screws

4. If previously removed, position the band clamp (A) onto the filter element flange with the band clamp screw mechanism in the cover flange cutout.



5. Install the air filter element/cover assembly onto the intake tube approximately 5/8 inch (16 mm). Check that the decorative cover is oriented in the desired position and the band clamp screw mechanism is hidden from view, yet the screw slot is accessible for tightening.
6. Tighten the clamp around the filter element flange to:
Torque: 5.1–6.2 N·m (45–55 in-lbs)

▲ WARNING

Connect positive (+) battery cable first. If positive (+) cable should contact ground with negative (-) cable connected, the resulting sparks can cause a battery explosion, which could result in death or serious injury. (00068a)

7. Connect battery cables according to service manual.

▲ WARNING

After installing seat, pull upward on seat to be sure it is locked in position. While riding, a loose seat can shift causing loss of control, which could result in death or serious injury. (00070b)

8. Install seat according to service manual.

MAINTENANCE AND CLEANING

1. Thoroughly clean chrome with a good quality chrome cleaner, such as Harley® Bright Chrome Cleaner (part no. 94683-99).
2. After cleaning and polishing, seal the finish with a good quality sealer such as Harley® Glaze, Polish and Sealant (part no. 99701-84).

SERVICE PARTS

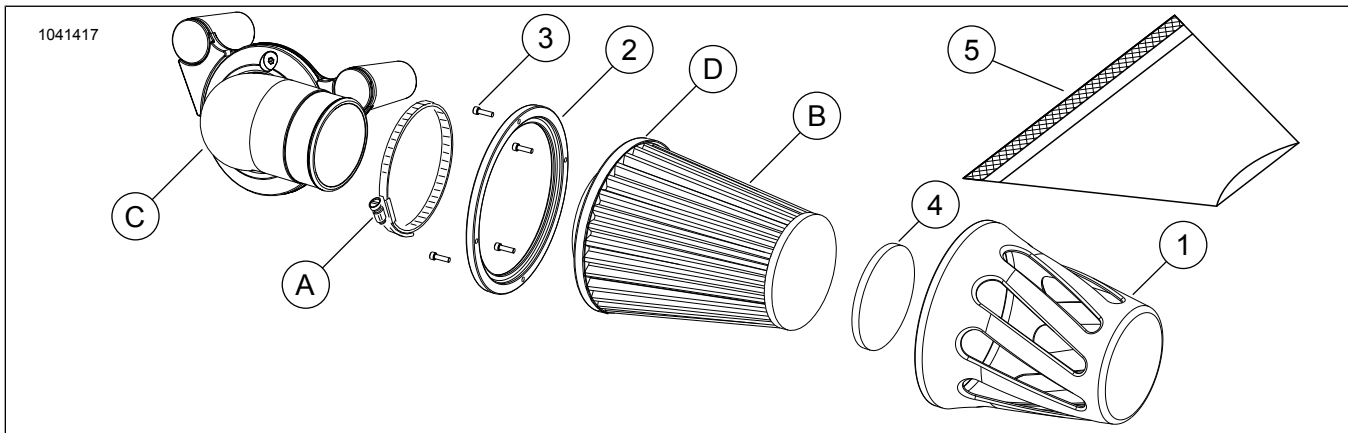

Figure 1. Service Parts: Heavy Breather Decorative Cover (Twisted Slot Shown)

Table 1. Service Parts Table

Item	Description (Quantity)	Part Number
1	Air cleaner cover, Twisted Slot (chrome)	Not Sold Separately
	Air cleaner cover, Twisted Slot (black)	Not Sold Separately
	Air cleaner cover, Teardrop (chrome) (Not Shown)	Not Sold Separately
	Air cleaner cover, Teardrop (black) (Not Shown)	Not Sold Separately
2	Mounting ring (chrome)	Not Sold Separately
	Mounting ring (black)	Not Sold Separately
3	Screw (4)	2260
4	Foam pad	28733-10
5	Air filter rain sock	28751-10A
Items mentioned in text, but not included in kit:		
A	Band clamp	
B	Filter element	
C	Intake tube	
D	Band clamp cover	