



# INSTRUCTIONS

J01459

2011-02-24



## FLSTC AND FLSTS DOCKING HARDWARE WITH SADDLEBAG SUPPORTS

### GENERAL

#### Kit Number

53822-00A

#### Models

For model fitment information, see the P&A Retail Catalog or the Parts and Accessories section of [www.harley-davidson.com](http://www.harley-davidson.com) (English only).

#### Additional Parts Required

2000-2001 FLSTS require Turn Signal Relocation Kit (Part No. 53820-00). 2002 FLSTS require Turn Signal Relocation Kit (Part No. 53859-02A) installed before installing this kit. Do not use Turn Signal Relocation Kit (Part No. 68458-87A) with this kit.

#### ⚠ WARNING

Rider and passenger safety depend upon the correct installation of this kit. If the procedure is not within your capabilities or you do not have the correct tools, have a Harley-Davidson dealer perform the installation. Improper installation of this kit could result in death or serious injury. (00308b)

#### Kit Contents

See Figure 1 and Table 1.

### REMOVAL

#### FLSTS Saddlebag Assembly Removal

1. See Figure 1. Remove each saddlebag by removing the acorn nut and washer on the lower support and the two flange locknuts inside the bag. Discard the flange locknuts but retain the acorn nut and washer.
2. Remove the saddlebag support studs and mounting hardware.

#### FLSTC Saddlebag Assembly and Sissy Bar Removal

1. See Figure 1. Remove each saddlebag by removing the acorn nut and washer on the lower support and the two flange locknuts inside the bag. Discard the flange locknuts but retain the acorn nut and washer.
2. Remove the saddlebag support studs and mounting hardware.
3. Remove and discard sissy bar assembly. Be careful not to scratch the fender while removing the sissy bar.

### INSTALLATION

#### ⚠ WARNING

Be sure fasteners do not extend inward beyond fender mounting bracket. Fastener contact with tire can lead to premature tire failure, which could result in death or serious injury. (00389a)

#### NOTE

For 2000-2002 Softail models with a Wide Tire Kit installed, install the fasteners according to the instructions included with the Wide Tire Kit to prevent the fasteners from interfering with the tire.

#### Docking Hardware Installation

1. Install front docking point (2) on front stud (1), with countersunk end facing fender support.
2. Install spacer (6) on rear stud.
3. Install rear docking point (8) on bolt (7), with countersunk end facing fender support.
4. Insert front stud (1) through fender support and secure with washer (4) and nut (5).
5. Insert rear stud (1) through fender support and secure with washer (4) and nut (5).
6. Install bolt (7) through fender support and secure with washer (4) and nut (5).
7. Tighten studs (1) and bolt (7) to 37 N·m (27 ft-lbs).
8. Repeat procedure for the opposite side of the motorcycle.

#### Saddlebag Installation

1. See Figure 1. Slip saddlebag mount onto studs (1) and install flanged locknuts (9).
2. Attach bottom part of saddlebag support to the lower support. Tighten acorn nut to 22–27 N·m (16–20 ft-lbs).
3. Repeat steps 1 and 2 to mount other saddlebag.
4. **U.S. Customers only:** Install the reflectors included in your kit in the locations shown according the instructions included the saddlebag kit.

## Reflector Installation

1. Hold the reflector against the lower, center of the saddlebag and mark the hole location.
2. Punch a hole in the saddlebag at the marked location.
3. Install a screw (10), reflector (3), washer (11) and nut (12) to the saddlebag.
4. Repeat procedure for the opposite side saddlebag.

After 500 miles of on-road use with the saddlebags installed, check that the saddlebag mounting nuts are tightened to 22–27 N·m (16–20 ft-lbs).

### NOTE

*In time docking points may wear, causing the mating luggage rack or sideplates to become loose and rattle. The fit may be tightened using the following procedure.*

1. Loosen the docking hardware.
2. Rotate the docking points clockwise approximately 45°.
3. Tighten the docking hardware to 37 N·m (27 ft-lbs).
4. Repeat as required, up to three adjustments. After the third adjustment, new docking points must be installed.

## MAINTENANCE

### NOTICE

**Failure to tighten saddlebag mounting bolts to specified torque could result in damage to saddlebags. (00406c)**

## SERVICE PARTS

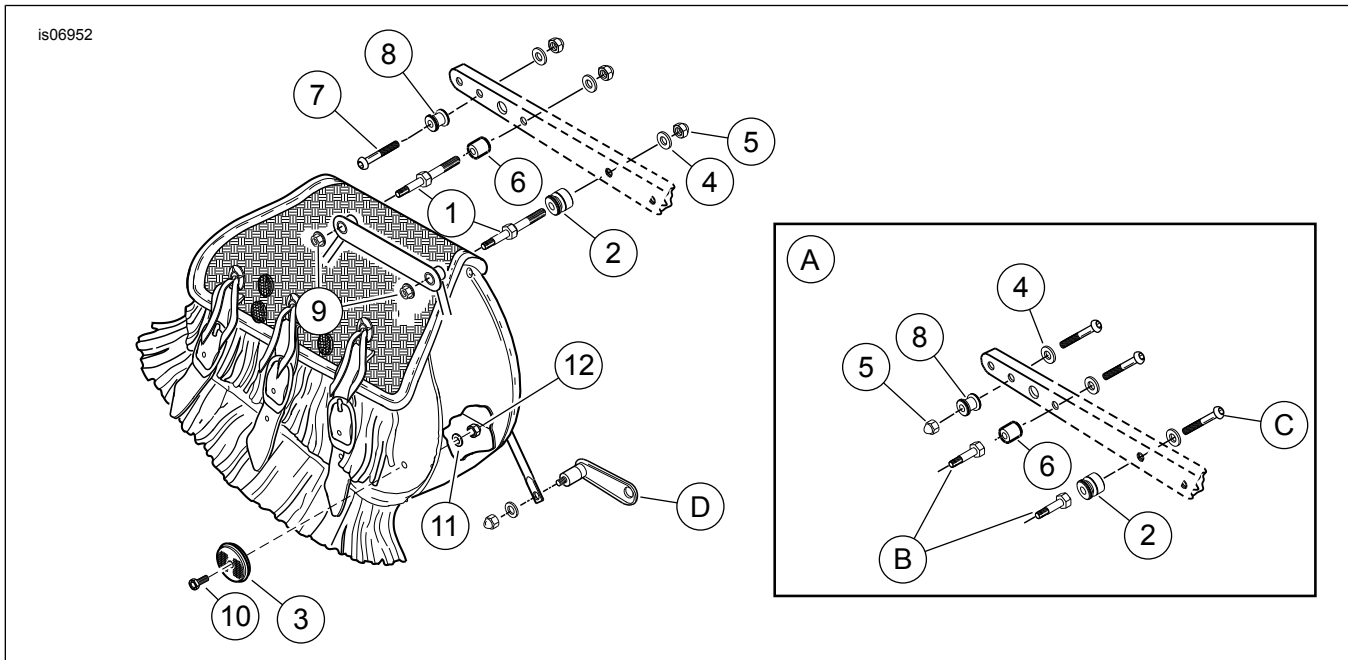

Figure 1. Service Parts: FLSTC and FLSTS Docking Hardware with Saddlebag Supports

Table 1. Service Parts Table

Item	Description (Quantity)	Part Number
1	Stud (4)	90349-97
2	Docking point, front (2)	53683-96
3	Reflector (2)	59264-86
4	Washer (6)	6701
5	Locknut, thin (6)	7667
6	Spacer (2)	53823-00
7	Screw, socket button head, 3/8-16 x 2-1/4 in (2)	4154
8	Docking point, rear (2)	53684-96A
9	Locknut, flanged, 5/16-18 (4)	7531
10	Screw, reflector (2)	2587
11	Washer, reflector (2)	6716
12	Nut, reflector	7626W
<b>Items mentioned in text, but not included in kit:</b>		
A	Configuration for Wide Tire Kit Installations	
B	Stud (part no. 90197-00) from Wide Tire Kit	
C	Button head screw (part no. 4228) from Wide Tire Kit	
D	Lower support	