



INSTRUCTIONS

J06690

2018-08-20



ENGINE GUARD MOUNTING BRACKET

GENERAL

Kit Number

45700054

Models

For model fitment information, see the P&A Retail Catalog or the Parts and Accessories section of www.harley-davidson.com (English only).

▲ WARNING

Rider and passenger safety depend upon the correct installation of this kit. If the procedure is not within your capabilities or you do not have the correct tools, have a Harley-Davidson dealer perform the installation. Improper installation of this kit could result in death or serious injury. (00308b)

Kit Contents

See Figure 1 and Table 1.

REMOVAL

1. Figure 1 Remove screw (B) and P-clamp (A) from steering damper mounting bracket (1).
2. Remove nut (H), washer (G) and steering damper (I) from steering damper mounting bracket (1).
3. Remove screw (K), nut, and steering damper bracket (1) from frame.

INSTALLATION

1. Install new steering damper mounting bracket with engine guard, following the engine guard mounting instructions.
 - a. Insert engine guard screw (K) and washer (J) through steering damper bracket (1) before frame and engine guard.
 - b. If engine guard did not include, use included screws (2) for lower mounting points.
 - c. Ensure steering damper mounting bracket tabs rest against top of engine guard tube when screw is tightened.
2. After engine guard is securely fastened, install steering damper (I) with Original Equipment (OE) nut (H) and washer (G) removed earlier. Tighten.
Torque: 21.7–27.1 N·m (16.0–20.0 ft-lbs)
3. Install OE p-clamp (A) and screw (B) removed earlier in original orientation. Tighten.
Torque: 4.5–5.4 N·m (39.8–47.8 in-lbs)
4. Remove screw (F) and acorn nut (D) securing steering damper to steer head.
5. Install OE screw (F) in opposite direction with acorn nut (D) on top of steer head mounting tab (C). Tighten.
Torque: 21.7–27.1 N·m (16.0–20.0 ft-lbs)



SERVICE PARTS

1169105

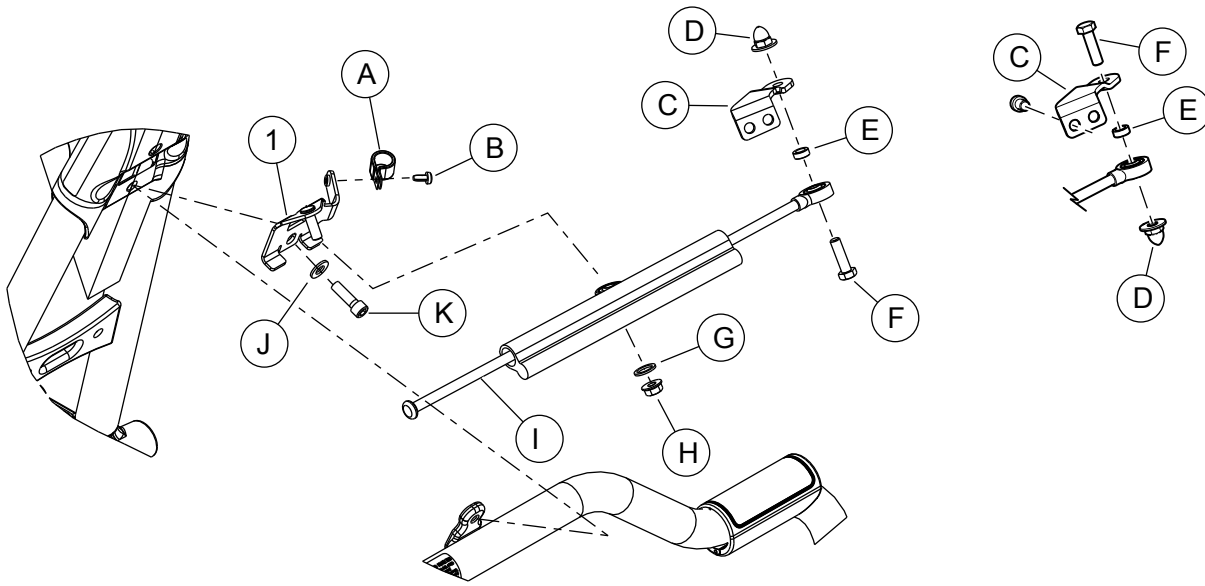

Figure 1. Service Parts: Engine Guard Mounting Bracket Kit

Table 1. Service Parts Table

Item	Description (Quantity)	Part Number
1	Steering damper mounting bracket	Not sold separately
2	Button head torx screw (2) (not shown)	4924
Items mentioned in text but not included in kit		
A	P-clamp	
B	Screw, P-clamp	
C	Side mounting bracket	
D	Acorn nut	
E	Spacer	
F	Screw	
G	Nylon washer	
H	Locknut	
I	Steering Damper	
J	Washer	
K	Screw	