



INSTRUCTIONS

94100550

2024-08-01



RIDER FOOTBOARD - TOURING

GENERAL INFORMATION

Table 1. General Information

Kits	Suggested Tools	Skill Level ⁽¹⁾
50502250A, 50502251A	Safety Glasses, Torque Wrench	

(1) Tightening to torque value or other moderate tools and techniques required

KIT CONTENTS

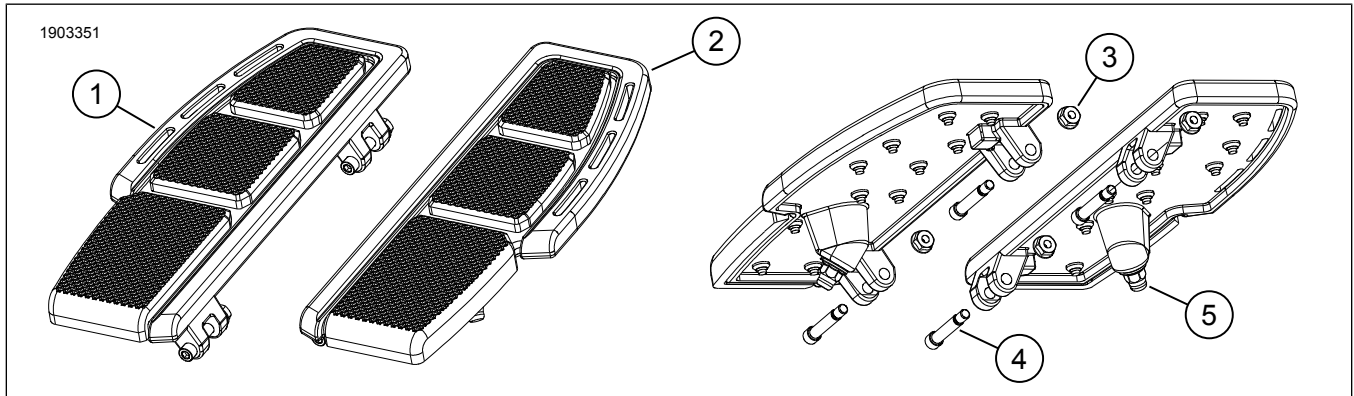

Figure 1. Kit Contents: Rider Footboard Components

Table 2. Kit Contents: Rider Footboard Components

<input checked="" type="checkbox"/>	Item	Qty	Description	Part No.	Notes
<input type="checkbox"/>	1	1	Footboard assembly, right side, gray	50502323	
<input type="checkbox"/>		1	Footboard assembly, right side, black	50502322	
<input type="checkbox"/>	2	1	Footboard assembly, left side, gray	50502325A	
<input type="checkbox"/>		1	Footboard assembly, left side, black	50502324A	
<input type="checkbox"/>	3	4	Screw	10200986	
<input type="checkbox"/>	4	4	Locking nut, flange	7716	
<input type="checkbox"/>	5	2	Wear peg	50500628	
<input type="checkbox"/>	6	2	Wear plate (not shown)	50502575	
<input type="checkbox"/>	7	2	Screw, wear plate (not shown)	10200659	

NOTE

Verify that all contents are present in the kit before installing or removing items from vehicle.

GENERAL

Models

For model fitment information, see the P&A Retail Catalog or the Parts and Accessories section of www.harley-davidson.com (English only).

Verify that the most current version of the instruction sheet is used. It is available at: www.harley-davidson.com/isheets

Contact Harley-Davidson Customer Support Center at 1-800-258-2464 (U.S. only) or 1-414-343-4056.

Installation Requirements

FLTRXSTSE models: Separate purchase of Front Support Mounts (Part No. 47200302A - qty of 2) is required. See service manual for removal of old front supports and install of **new** supports.

LOCTITE 243 MEDIUM STRENGTH THREADLOCKER AND SEALANT (BLUE) (99642-97)

⚠ WARNING

Rider and passenger safety depend upon the correct installation of this kit. If the procedure is not within your capabilities or you do not have the correct tools, have a Harley-Davidson dealer perform the installation. Improper installation of this kit could result in death or serious injury. (00308b)

REMOVE

1. Remove two hinge bolts and locknuts attaching existing footboard to mounting brackets.
2. Remove footboard.
3. Vehicle hardware:

INSTALL

1. Figure 1 Set correct footboard in place over mounting brackets. Wear peg should be toward rear of vehicle.
2. Align holes, install pivot screws (1) and locking nuts (2).
3. Locking nuts should be on inboard side. Tighten.
Torque: 9–12 N·m (80–106 **in-lbs**)
4. Check that footboard pivots freely on hinge bolts.
 - a. If it does not, then loosen front footboard support bracket lower screw. Re-center in bracket in footboard groove. Tighten.
Torque: 49–57 N·m (36–42 ft-lbs)
5. Repeat for opposite side.

Wear Peg Replacement

1. When servicing wear peg, remove existing wear peg from footpeg.

2. Apply two or three drops of threadlocker to threads of **new** wear peg.

Consumable: LOCTITE 243 MEDIUM STRENGTH THREADLOCKER AND SEALANT (BLUE) (99642-97)

3. Install **new** wear peg to footpeg.

Torque: 3.6–4.7 N·m (32–42 **in-lbs**)