



INSTRUCTIONS

J06176

2022-03-08



SCREAMIN' EAGLE 110 (1800 CC) CONVERSION KIT - STOCK HEADS

GENERAL

Kit Number

92500035

Models

For model fitment information, see the P&A Retail Catalog or the Parts and Accessories section of Refer to: www.harley-davidson.com.

Verify that the most current version of the instruction sheet is used. It is available at: Refer to: h-d.com/isheets

Contact Harley-Davidson Customer Support Center at 1-800-258-2464 (U.S. only) or 1-414-343-4056.

Installation Requirements

▲ WARNING

Rider and passenger safety depend upon the correct installation of this kit. Use the appropriate service manual procedures. If the procedure is not within your capabilities or you do not have the correct tools, have a Harley-Davidson dealer perform the installation. Improper installation of this kit could result in death or serious injury. (00333b)

NOTE

This instruction sheet references service manual information. A service manual for your model motorcycle is required for this installation and is available from:

- A Harley-Davidson dealer
- H-D Service Information Portal, a subscription-based access available for most 2001 and newer models. For more information see Refer to: Frequently ask questions about subscriptions.

NOTE

Do not use stock CVO pistons with the 4 in Bolt-on Cylinders or interference occurs between the pistons and crankcase.

These items are available at your local Harley-Davidson dealership.

- **2014-2016 Twin-Cooled Touring models:** Separate purchase of Cylinder Head Gasket (Part No. 16500168) is required for installation.
- Separate purchase of Screamin' Eagle Pro Street Tuner (Part No. 41000008C) is required for this installation.
- Digital Technician II (DT II) is required for this installation.

Kit Contents

See Figure 1 to Figure 4, and Table 1 to Table 4.

NOTE

Installation of this kit by an authorized Harley-Davidson dealer will not impact your limited vehicle warranty.

The kit is intended for High Performance applications only. This engine-related performance kit is legal for sale or use in select countries or regions on pollution controlled motor vehicles. Check with your local Harley-Davidson dealer for compliance requirements in your area.

A partial emissions tune-up label and a product information label are included with this kit as a requirement of the California Air Resource Board (CARB)/EPA emissions regulation. Locate the emissions label on the frame tube below the handlebars. Place the new partial label from this kit over the **top portion** of the emissions label on the frame tube.

REMOVAL

Prepare for Service

1. Disarm security system.
2. Raise the motorcycle.
3. See the service manual. Remove seat.
4. See the service manual. Remove main fuse.

▲ WARNING

When servicing the fuel system, do not smoke or allow open flame or sparks in the vicinity. Gasoline is extremely flammable and highly explosive, which could result in death or serious injury. (00330a)

5. See the service manual. Remove fuel tank.

Remove Engine Components

1. See the service manual. Remove existing air cleaner assembly.
2. See the service manual. Remove existing exhaust system.
3. See the service manual. Disassemble engine top end and cam plate assembly.
4. See the service manual. Remove existing clutch diaphragm spring.



INSTALLATION

Install Engine and Clutch Components

1. See Figure 4. Install new inner cam bearings included with this kit.
2. See Figure 1 through Figure 4. Assemble cams to cam plate and engine top end using parts from kit. Refer to appropriate ENGINE sections in service manual.
3. See the service manual. See Install clutch diaphragm spring from kit.
4. Install valve spring kit and seals. Follow instructions in valve spring and seal kit.
5. See the service manual. Install exhaust system.
6. Install air cleaner assembly. Follow instructions in air cleaner kit.

Final Assembly

1. See the service manual. Install fuel tank.
2. See the service manual. Install seat.
3. See the service manual. Install main fuse.

SERVICE PARTS

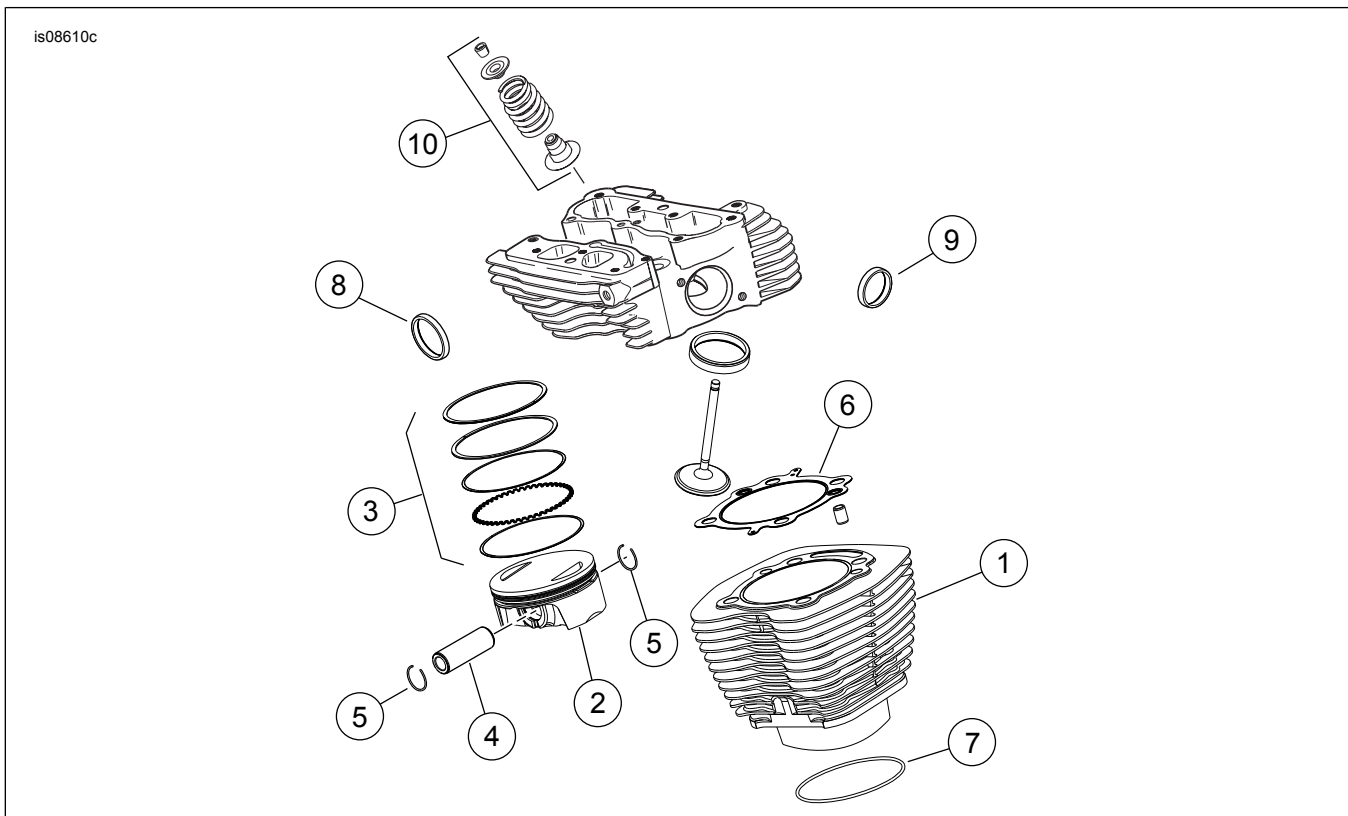

Figure 1. Service Parts: Screamin' Eagle Twin Cam 110 (1800 cc) Conversion Kit - Stock Heads

Table 1. Service Parts: Screamin' Eagle Twin Cam 110 (1800 cc) Conversion Kit - Stock Heads

Item	Description (Quantity)	Part Number	Item	Description (Quantity)	Part Number
1	Cylinder assembly (Black) (2)	16800102	6	Gasket, cylinder head (2)	16801-07B
2	Piston (2)	Not Sold Separately	7	O-ring, cylinder spigot (2)	11256
3	Piston Ring Set (2)	21951-11	8	Gasket, exhaust port (2)	65324-99A
4	Piston pin (2)	22100001	9	Seal, intake manifold (2)	26995-86B

⚠ WARNING

After installing seat, pull upward on seat to be sure it is locked in position. While riding, a loose seat can shift causing loss of control, which could result in death or serious injury. (00070b)

NOTICE

You must recalibrate the ECM when installing this kit. Failure to properly recalibrate the ECM can result in severe engine damage. (00399b)

4. Download the new ECM calibration using the Digital Technician™ at a Harley-Davidson dealer or using Screamin' Eagle Street Performance Tuner Kit.
5. Run engine. Repeat several times to verify proper operation.

Operation

Refer to BREAK-IN RIDING RULES in the Owner's Manual to break in the motorcycle.

Table 1. Service Parts: Screamin' Eagle Twin Cam 110 (1800 cc) Conversion Kit - Stock Heads

Item	Description (Quantity)	Part Number	Item	Description (Quantity)	Part Number
5	Piston pin circlip (4)	22097-99	10	Valve spring and seal kit	18013-03A

Notes: Piston Kit (2190050) includes 2 through 5.
Item 6 through 9 are also included in Top End and Cam Gasket Kit (16500385).

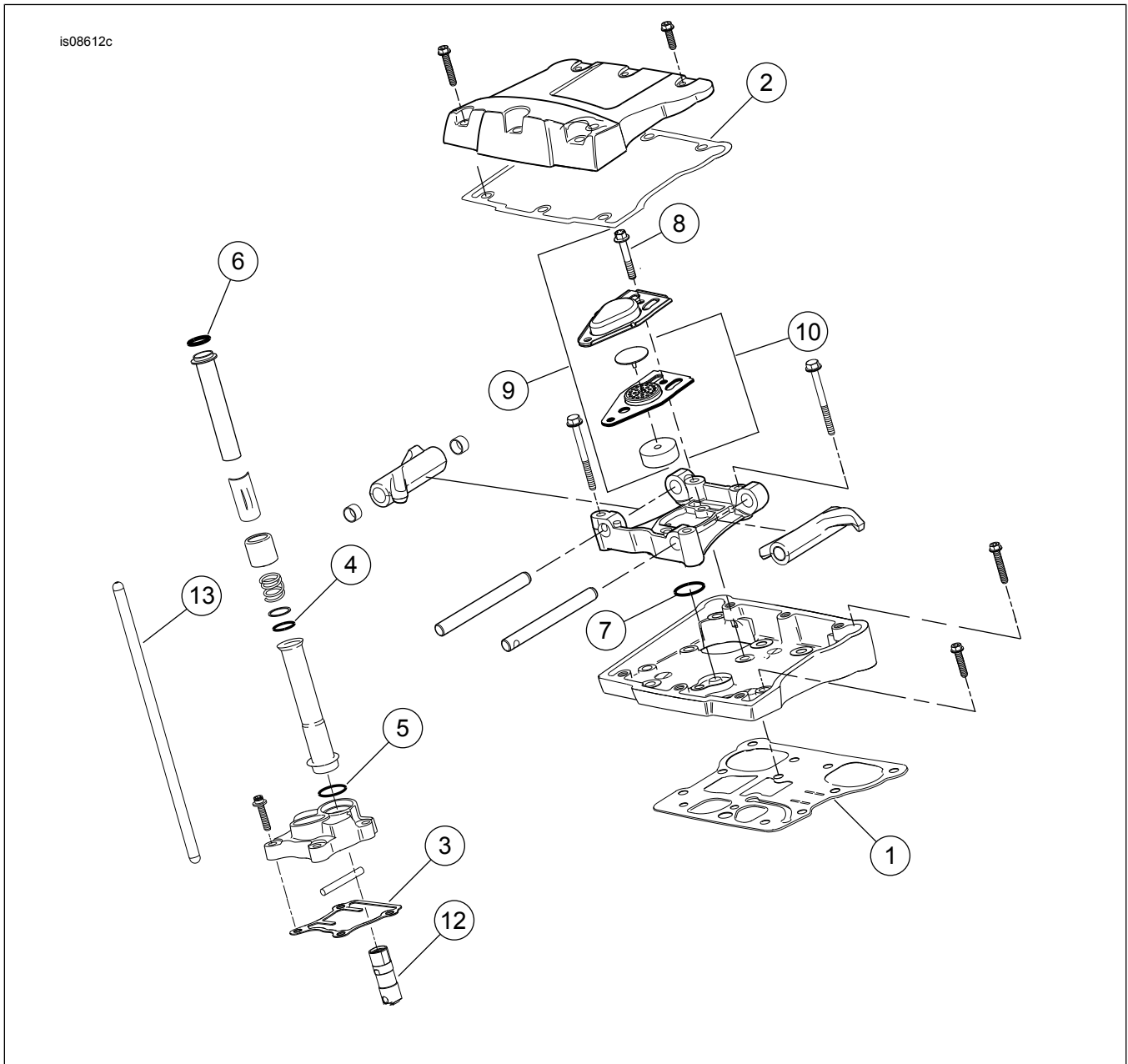

Figure 2. Service Parts: Screamin' Eagle Twin Cam 110 (1800 cc) Conversion Kit - Stock Heads

Table 2. Service Parts: Screamin' Eagle Twin Cam 110 (1800 cc) Kit - Stock Heads

Item	Description (Quantity)	Part Number	Item	Description (Quantity)	Part Number
1	Gasket, rocker cover base (2)	16719-99B	8	Breather bolt (4)	4400
2	Gasket, rocker cover top (2)	17386-99A	9	Breather assembly (2)	17025-03A
3	Gasket, tappet cover (2)	18635-99B	10	Baffle assembly (2) [includes gaskets (2)]	26500002
4	O-ring, middle push rod cover (4)	11132A	11	Spring, clutch diaphragm (2) (Not Shown)	37951-98
5	O-ring, lower push rod cover (4)	11145A	12	High capacity tappet kit	18572-13
6	O-ring, upper push rod cover (4)	11293	13	Perfect fit pushrod kit (+.030 in)	18401-03
7	O-ring, rocker arm support (2)	11270	Notes: Items 1 through 10 are included in Top End and Cam Gasket Kit (16500385).		

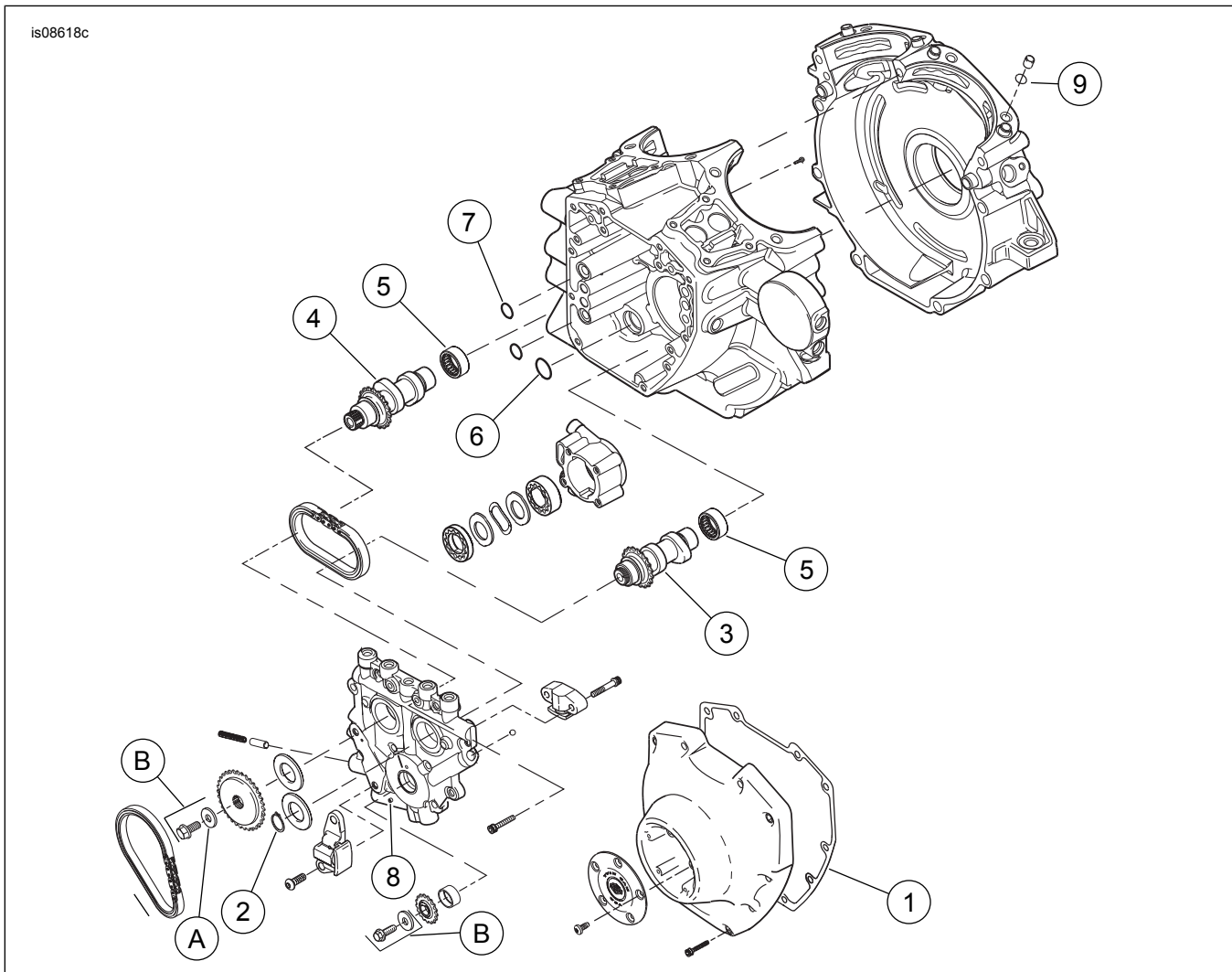

Figure 3. Service Parts: Screamin' Eagle Twin Cam 110 (1800 cc) Conversion Kit - Stock Heads

Table 3. Service Parts: Screamin' Eagle Twin Cam 110 (1800 cc) Conversion Kit - Stock Heads

Item	Description (Quantity)	Part Number
1	Gasket, cam cover	25244-99A
2	Retaining ring	11461
3	Camshaft, front	Not Sold Separately
4	Camshaft, rear	Not Sold Separately
5	Bearing kit, needle, left side (2)	24018-10
6	O-ring, oil pump to cam plate	11293
7	O-ring, cam plate to crankcase (2)	11301
8	Roll pin	601
9	O-ring, crankcase dowel (2)	11273
Items mentioned in text, but not included in kit:		
A	Washer	6294
B	Cam drive retention kit (includes screw and washer)	25566-06
Items 3 and 4 are available in Cam Kit (25400117)		
Items 1, 2, and 5 through 9 are included in 4 in Bolt-On Kit Twin Cam Top End and Cam Gasket Kit (16500385)		

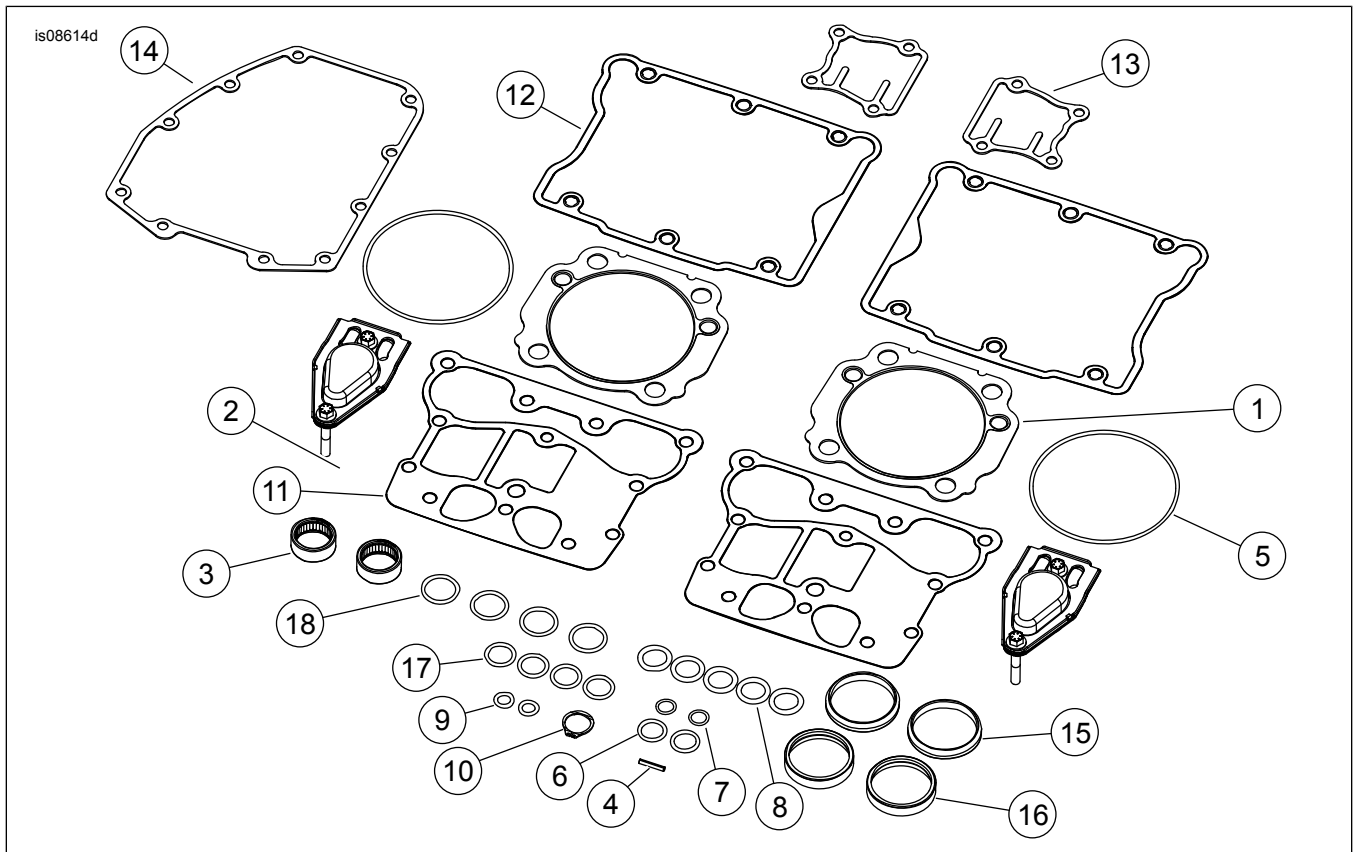

Figure 4. Service Parts: Screamin' Eagle Twin Cam 110 (1800 cc) Conversion Kit - Stock Heads

Table 4. Service Parts: Screamin' Eagle Twin Cam 110 (1800 cc) Conversion Kit - Stock Heads

Item	Description (Quantity)	Part Number
1	Gasket, cylinder head (2)	16801-07B
2	Breather assembly (2)	17025-03A
3	Bearing kit, needle, left side, camshaft (2)	24018-10
4	roll pin, cam plate pressure relief	601
5	O-ring, cylinder spigot (2)	11256
6	O-ring, rocker arm support (2)	11270
7	O-ring, crankcase dowel (2)	11273
8	O-ring, upper push rod cover (4), oil pump to cam plate (1)	11293
9	O-ring, cam plate to crankcase (2)	11301
10	Retaining ring	11461
11	Gasket, rocker cover base (2)	16719-99B
12	Gasket, rocker cover top (2)	17386-99A
13	Gasket, Tappet cover (2)	18635-99B
14	Gasket, cam cover	25244-99A
15	Seal, intake manifold (2)	26995-86B
16	Gasket, exhaust port (2)	65324-83B
17	O-ring, middle push rod cover (4)	11132A
18	O-ring, lower push rod cover (4)	11145A
Items mentioned in text, but not included in kit:		
A	Valve seal (4) (not shown) (not required)	18094-02A
Items 1, through 18 are included in 4 in Bolt-on Air Cooled Top End and Cam Gasket Kit (Part no. 16500385).		