



# INSTRUCTIONS

94100230

2025-01-23



## UNIVERSAL PHONE CARRIER PLUS CLUTCH MOUNT

### GENERAL INFORMATION

Table 1. General Information

Kits	Suggested Tools	Skill Level <sup>(1)</sup>
76001071, 76001339, 76001071A, 76001339A	Safety Glasses, Torque Wrench, Isopropyl alcohol	
<i>(1) Tightening to torque value or other moderate tools and techniques required</i>		

### KIT CONTENTS

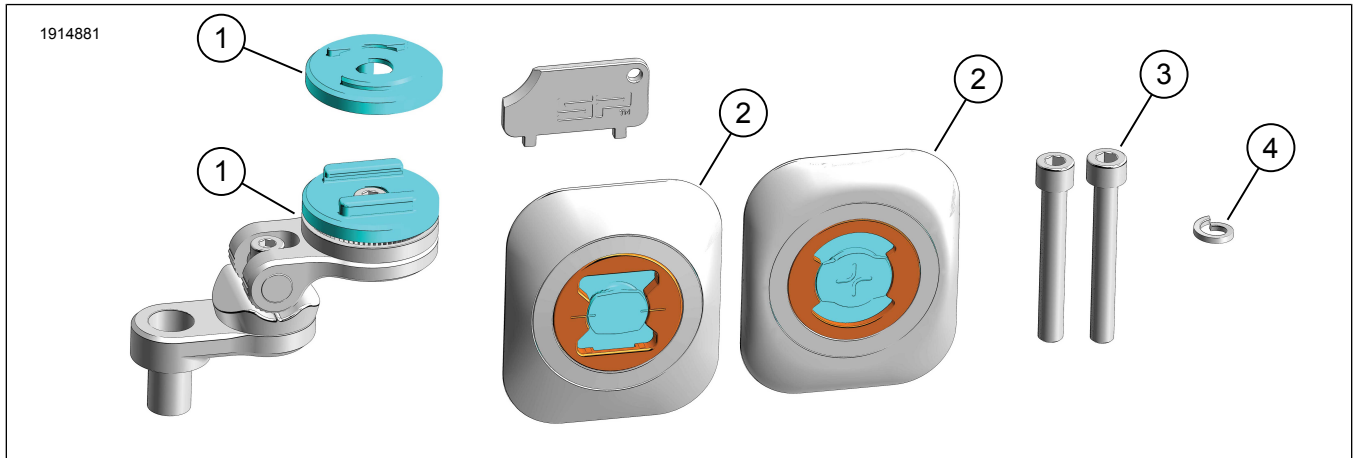

Figure 1. Kit Contents: Universal Phone Carrier w/ Clutch Mount

Table 2. Kit Contents: Universal Phone Carrier w/ Clutch Mount

<input checked="" type="checkbox"/>	Verify that all contents are present in the kit before installing or removing items from vehicle.				
Item	Qty	Description	Part No.	Notes	
<input type="checkbox"/>	1	Clutch Mount	Not sold separately		
<input type="checkbox"/>		Clutch Mount (SPC+)	Not sold separately		
<input type="checkbox"/>	1	Universal interface	76001081		
<input type="checkbox"/>		Universal interface (SPC+)	76001487		
<input type="checkbox"/>	1	Screw	Not sold separately		
<input type="checkbox"/>		Screw, M6	Not sold separately	<b>Sportster XL, Street XG, Pan America, RH models</b>	
<input type="checkbox"/>	1	Washer	Not sold separately		

### GENERAL

Instruction sheet is also available electronically. To verify you are using the most current version available, do one of the following:

- Go to [h-d.com/isheets](http://h-d.com/isheets)
- Scan QR code in upper left corner of the instruction sheet

#### NOTE

*This instruction sheet may have a Supplemental Video to assist installer in clarifying a certain part of the assembly. A linked video would be located at the end of this instruction sheet.*

## Models

For model fitment information, see the Parts and Accessories (P&A) Retail Catalog or the Parts and Accessories section of [www.harley-davidson.com](http://www.harley-davidson.com).

Contact Harley-Davidson Customer Support Center at 1-800-258-2464 (U.S. only) or 1-414-343-4056.

## Installation Requirements

### ▲ WARNING

Rider and passenger safety depend upon the correct installation of this kit. Use the appropriate service manual procedures. If the procedure is not within your capabilities or you do not have the correct tools, have a Harley-Davidson dealer perform the installation. Improper installation of this kit could result in death or serious injury. (00333b)

### NOTE

This instruction sheet references service manual information. A service manual for the year and model motorcycle is required for this installation and is available from:

- A Harley-Davidson dealer.
- H-D Service Information Portal, a subscription-based access available for most 2001 and newer models. For more information see *Frequently ask questions about subscriptions*.

## REMOVE

1. Figure 2 Remove upper screw (2) and washer (1) from left side clutch mount. Discard.
2. **Livewire Models:** Figure 2 Remove upper screw (2) and washer (1) from left side mirror mount. Discard.

## INSTALL

### Universal Phone Mount

1. Prior to tightening phone mount bolt (3), adjust clocking to enable viewing without obstructing functions of the motorcycle.
2. **Touring, Trike, Softail, Dyna, Livewire Models:** Figure 3 Install screw (3) and lockwasher (4) to left side clutch mount. Tighten.  
Torque: 6.78–9.03 N·m (60–80 in-lbs)
3. **Sportster XL, Street XG, Pan America, RH Models:** Figure 3 Install M6 screw (3) and lockwasher (4) to left side mirror mount. Tighten.  
Torque: 6.78–9.03 N·m (60–80 in-lbs)
4. Figure 4 Loosen screw (B) to adjust orientation on clamp pivot. Tighten.  
Torque: 6.78–9.03 N·m (60–80 in-lbs)
5. Figure 4 Loosen screw (C) on phone interface (3) to adjust phone clocking. Tighten.  
Torque: 1.58–1.92 N·m (14–17 in-lbs)

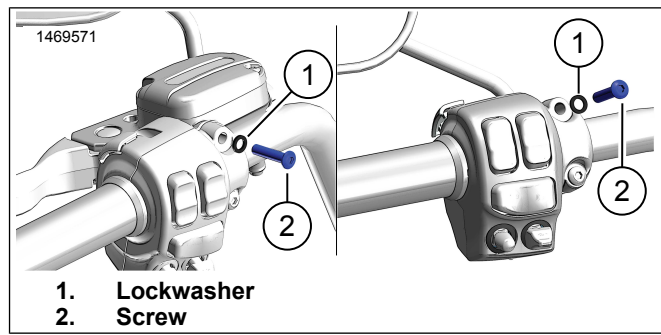

Figure 2. Upper Left Side Clutch/Mirror Mount Screw and Washer

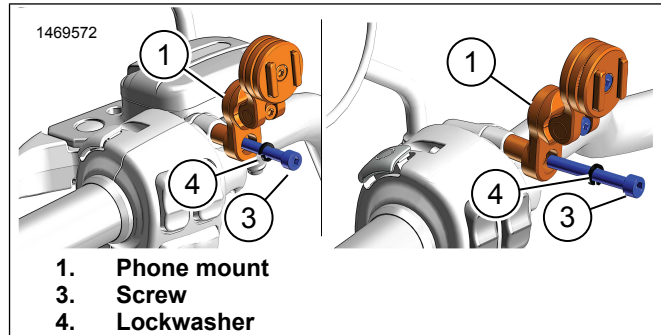

Figure 3. Phone Mount Install to Left Side Clutch/Mirror Mount

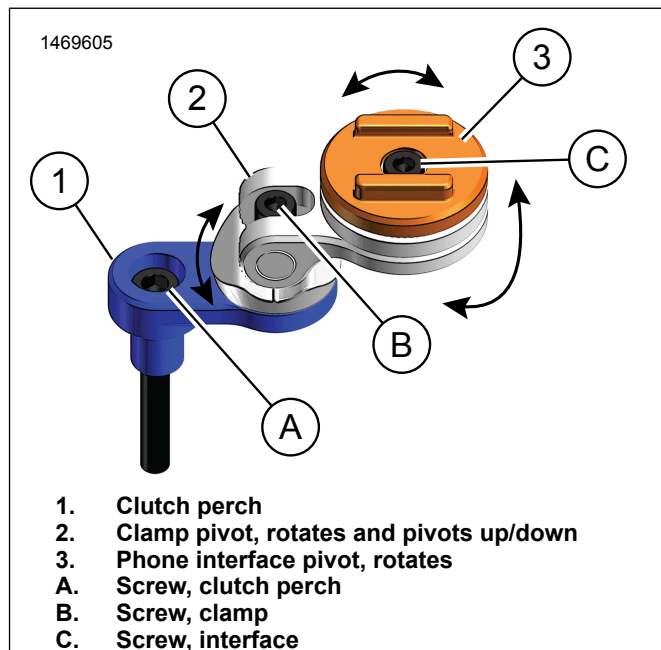

Figure 4. Pivot Points

## Universal Interface

### NOTE

- Contaminated or oily surfaces can cause improper adhesion and can result in loss or damage to phone.
- Some smart phones have non-stick or water resistant nano-particle coatings that repel the adhesive or have removable battery covers that could come loose.
- Adhesive will not adhere to rough, uneven surfaces.

- Smooth and non-porous surface areas of at least 2.16 in. (55mm) x 2.56 in. (65mm) is needed for interface to be placed on.
- Position adapter carefully. Adhesive mount cannot be reused.
- It is the owner's responsibility to verify a good adhesive bond strength between phone case and universal interface.
- For more information on phone cases with interface built in and not requiring adhesive, go to [www.harley-davidson.com](http://www.harley-davidson.com) and search for appropriate phone mount kit.

1. Figure 1 Install universal interface (2).
  - a. Clean phone case with isopropyl alcohol. Let dry before application of phone surface.
  - b. Apply adhesive at room temperature.
  - c. Apply firm pressure between universal interface and phone case for one minute.

- d. Allow adhesive bond to cure for 48 hours before using universal interface to support phone.

## Phone Install

1. Figure 5 Install phone to mount.
  - a. Align and insert tabs on phone interface to slots on phone case.

### NOTE

*Gently pull on phone to verify that it is properly installed and mount is locked*

- b. Turn phone a ¼ turn until phone settles into the next detent.
2. Adjust phone mount and phone orientation as needed for optimal access and viewing.

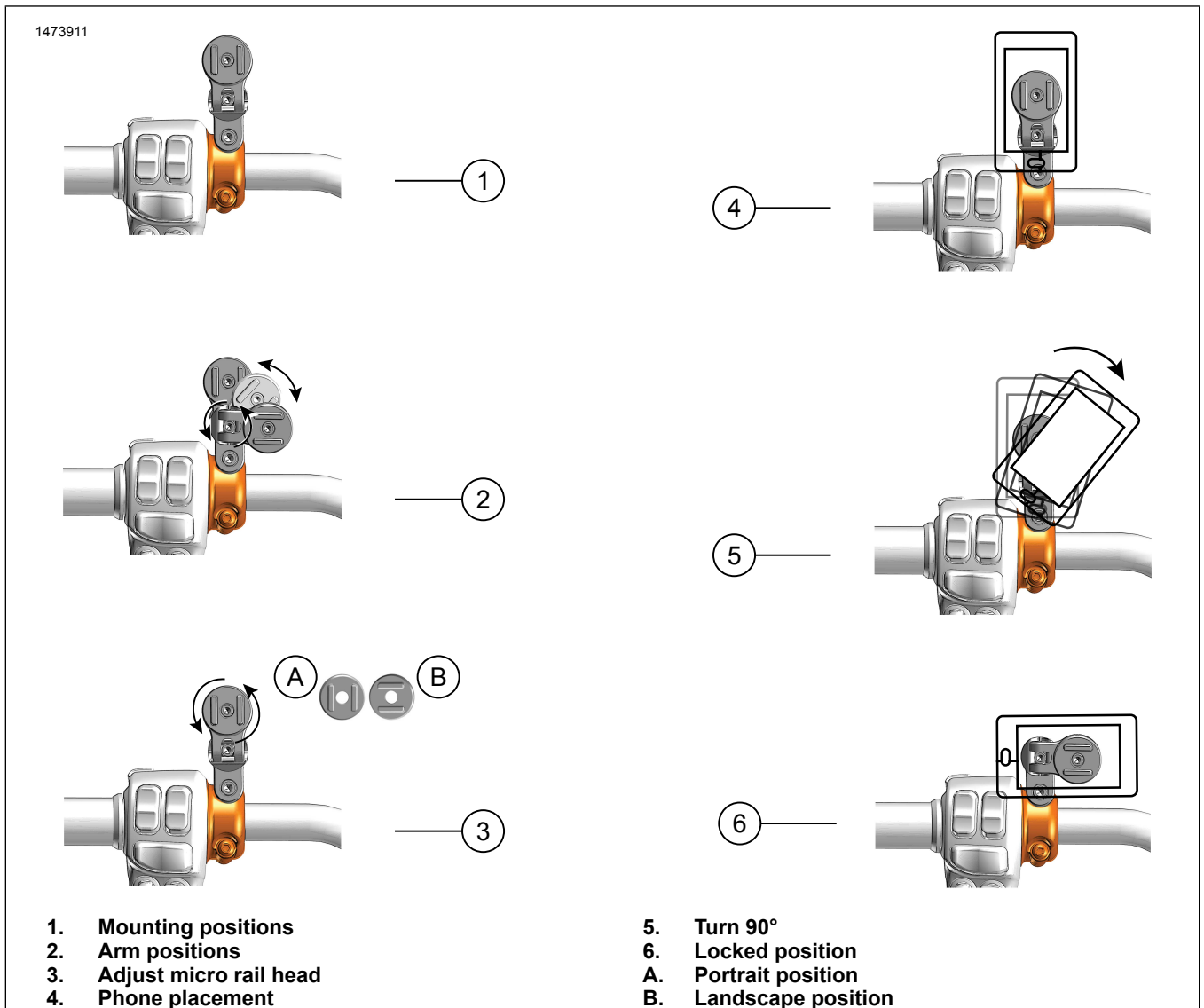

Figure 5. Phone Mount and Positioning Options

## COMPLETE

### ⚠ WARNING

**Be sure that steering is smooth and free without interference. Interference with steering could result in loss of vehicle control and death or serious injury. (00371a)**

1. Turn handlebar lock to lock after installation to verify that the phone carrier and phone do not interfere with fairings, gas tank, cables, lines, hoses, wiring or other equipment.
2. Make sure that the phone does not obscure visibility of speedometer, hand controls, indicator lights or mirrors.