



# INSTRUCTIONS

J06244

2025-01-23



## SE120R SCREAMIN' EAGLE PRO HIGH PERFORMANCE CRATE ENGINE (BETA)

### GENERAL

#### Kit Number

19206-16

#### Models

For model fitment information, see the P&A retail catalog or the Parts and Accessories section of [www.harley-davidson.com](http://www.harley-davidson.com) (English only).

#### NOTE

**This engine is for race use only! Remove the emissions label and license plate from the factory chassis.**

#### Table of Contents

Table 1. CONTENTS

Page	Subject
2	SE120R ENGINE INSTALLATION
3	SE120R ENGINE SPECIFICATIONS
3	MANUFACTURING TOLERANCES
4	SERVICE WEAR LIMITS
5	SE120R CYLINDERS
6	SE120R PISTONS
8	REPLACING/SERVICING PUSHRODS
9	SERVICE PARTS

#### Installation Requirements

- **Recommended synthetic engine oil:** Screamin' Eagle SYN3<sup>®</sup> 20W50 (Part No. 99824-03/00QT).
- **2007-2011 Softail models (except FXCW and FXCWC):** Installation of SE High Capacity Compensator Kit (Part No. 40274-08A) is **required** for installation of this engine.
- A clutch kit that supports a minimum of 190 N·m (140.1 ft-lbs) of torque. Harley-Davidson recommends installation of Screamin' Eagle pressure clutch (Part No. 37000121) and diaphragm spring (Part No. 37951-98). Drag racing applications use clutch kit (Part No. 37976-08A).
- SE throttle body, Air Cleaner and High Flow injectors. Refer to the Screamin' Eagle Pro catalog or contact a Harley-Davidson dealer.
- SE exhaust gaskets kit (Part No. 17048-98).
- Oil cooler is recommended. See P&A retail catalog or the Parts and Accessories section of [www.harley-davidson.com](http://www.harley-davidson.com) (English only).
- SE Pro Super Tuner. Refer to Screamin' Eagle Pro catalog or contact a Harley-Davidson dealer.
- See appropriate sections in service manual for the special tools required to install this kit.

#### ⚠ WARNING

Rider and passenger safety depend upon the correct installation of this kit. Use the appropriate service manual procedures. If the procedure is not within your capabilities or you do not have the correct tools, have a Harley-Davidson dealer perform the installation. Improper installation of this kit could result in death or serious injury. (00333b)

#### NOTE

This instruction sheet refers to service manual information. A service manual for your year/model motorcycle is required for this installation. One is available from a Harley-Davidson dealer.

#### Kit Contents

See:

- Figure 7 and Table 14,
- Figure 8 and Table 15,
- Figure 9 and Table 16,
- Figure 10 and Table 17,
- Figure 11 and Table 18,
- Figure 12 and Table 19,
- Figure 14 and Table 21.
- Figure 13 and Table 20.

#### PREPARATION

1. Position the motorcycle on a suitable lift.

#### ⚠ WARNING

**When servicing the fuel system, do not smoke or allow open flame or sparks in the vicinity. Gasoline is extremely flammable and highly explosive, which could result in death or serious injury. (00330a)**

#### ⚠ WARNING

**To prevent spray of fuel, purge system of high-pressure fuel before supply line is disconnected. Gasoline is extremely flammable and highly explosive, which could result in death or serious injury. (00275a)**

2. See the service manual to perform the following steps:
  - a. Remove seat.
  - b. Purge and disconnect fuel supply line.



## ▲ WARNING

To prevent accidental vehicle start-up, which could cause death or serious injury, remove main fuse before proceeding. (00251b)

### NOTE

- **WITH security siren:** With security fob present, turn ignition switch ON. See the service manual. Disarm security system. Turn ignition switch OFF. **IMMEDIATELY** remove main fuse.
- **WITHOUT security siren:** See the service manual. Remove main fuse.

### ALL models:

3. See the service manual to perform the following steps:
  - a. Remove instrument console (if present) from fuel tank.
  - b. Remove fuel tank.
4. Raise the motorcycle.

## REMOVAL

### Current Engine Removal

1. Remove engine from chassis. Refer to ENGINE section of service manual.

### SE120R ENGINE INSTALLATION

1. Before installing the engine, make sure that there is no debris or contaminants in the oiling system. Have the oil pan flushed out by a Harley-Davidson dealer or qualified technician.
2. Remove the oil passage caps or plugs at the engine to transmission interface.
3. See the ENGINE section of the service manual. Install the engine to the chassis.
4. **2007-2011 Softail models (except FXCW and FXCWC):** Install a Screamin' Eagle High Capacity Compensator Kit (purchased separately), following instructions from **that** kit. Refer to the Screamin' Eagle Pro catalog or contact a Harley-Davidson dealer for the correct compensator kit. **2012-Later Softail Models, and All FXCW and FXCWC Models:** Install the original equipment (OE) compensator per service manual instructions.

## COMPLETION

1. Install fuel tank. See service manual.
2. Install main fuse. See service manual.
3. Install seat. After installing seat, pull up on seat to verify that it is secure. See service manual.

### NOTICE

You must recalibrate the ECM when installing this kit. Failure to properly recalibrate the ECM can result in severe engine damage. (00399b)

4. Download the new ECM calibration when installing this kit. Refer to the Screamin' Eagle Pro catalog or contact a Harley-Davidson dealer.

5. Start and run engine. Repeat several times to verify proper operation.

## OPERATION

Refer to BREAK-IN RIDING RULES in the vehicle owner's manual to break in the new engine.

## MAINTENANCE

1. Refer to the MAINTENANCE SCHEDULE in the vehicle service manual or owner's manual.
2. Refer to ENGINE section of service manual for proper service procedures.

## SE120R ENGINE SPECIFICATIONS

### NOTE

The following sections provide unique information not available in the service manual ENGINE section for Twin Cam 96™ beta engines on Softail platforms.

Table 2. Engine: Screamin' Eagle Twin Cam, SE120R

Item	Specification	
Compression Ratio	10.5:1	
Bore	4.060 in	103.12 mm
Stroke	4.625 in	117.48 mm
Displacement	119.75 cu in	1962.39 cc
Lubrication system	Pressurized dry sump with oil cooler	
Maximum sustained engine speed	6200 RPM	

## MANUFACTURING TOLERANCES

Refer to the Twin-Cam 96™ specifications in the service manual for any specification not shown in the following tables.

Table 3. Cylinder Heads

ITEM	IN.	MM
Valve guide in head (tight)	0.0020-0.0033	0.051-0.084
Intake valve seat in head (tight)	0.004-0.0055	0.102-0.140
Exhaust valve seat in head (tight)	0.004-0.0055	0.102-0.140

Table 4. Valves

ITEM	IN.	MM
Fit in guide (intake and exhaust)	0.0011-0.0029	0.028-0.074
Seat width	0.034-0.062	0.86-1.57
Stem protrusion from cylinder head boss	1.990-2.024	50.55-51.41

Table 5. Valve Springs Specifications

ITEM	PRESSURE	DIMENSION
Closed	180 lbs (79 kg)	1.800 in. (45.7 mm)
Open	500 lbs (196 kg)	1.177 in. (29.9 mm)
Free length	n/a	2.210 in. (56.1 mm)

Table 6. Pistons

Piston:	Clearance (in.)
Piston-to-cylinder fit (Loose)	0.0026-0.0036
Piston pin fit (Loose)	0.0003-0.0008

**Table 6. Pistons**

Piston:	Clearance (in.)
Top Ring End Gap	0.012-0.020
Second Ring End Gap	0.016-0.024
Oil Control Ring Rail Gap	0.008-0.0028
Top Ring Side Clearance	0.0010-0.0022
Second Ring Side Clearance	0.0010-0.0022
Oil Control Ring Side Clearance	0.0003-0.0072

**Table 7. Cam Specifications - SE266E**

Intake	Specification
Opens	24° BTDC
Closes	58° ABDC
Duration	262°
Max. Valve Lift	16.713 mm (1/2 in)
Valve Lift @ TDC	5.283 mm (0 in)
Exhaust	Specification
Opens	69° BBDC
Closes	17° ATDC
Duration	266°
Max. Valve Lift	16.713 mm (1/2 in)
Valve Lift @ TDC	4.521 mm (0 in)
Cam Timing @ 1.346 mm (0 in) of Tappet Lift in Crankshaft Degrees	

## SERVICE WEAR LIMITS

Use wear limits as guide to part replacement.

### NOTE

Refer to the Twin-Cam 96 specifications in the service manual for any specification not shown in the following tables

**Table 8. Cylinders**

ITEM	REPLACE IF WEAR EXCEEDS	
	IN.	MM
Taper	0.002	0.051
Out of round	0.002	0.051
Warpage of gasket or O-ring surfaces: top	0.006	0.152
Warpage of gasket or O-ring surfaces: base	0.004	0.102

**Table 9. Cylinder Bore**

ITEM	REPLACE IF WEAR EXCEEDS	
	IN.	MM
Standard	4.062	103.17
0.010 in. oversize	4.072	103.43

**Table 10. Pistons**

Piston-to-cylinder fit (Loose)	Wear Limit (in.)
Fit in cylinder (Loose)	0.0061
Piston Pin Fit (Loose)	0.0011
Top Ring End Gap	0.030
Second Ring End Gap	0.034
Oil Control Ring Rail Gap	0.038
Top Ring Side Clearance	0.0030
Second Ring Side Clearance	0.0030
Oil Control Ring Side Clearance	0.0079

## SE120R CYLINDERS

### Preparation

1. Position the motorcycle on a suitable lift.

### ⚠ WARNING

When servicing the fuel system, do not smoke or allow open flame or sparks in the vicinity. Gasoline is extremely flammable and highly explosive, which could result in death or serious injury. (00330a)

### ⚠ WARNING

To prevent spray of fuel, purge system of high-pressure fuel before supply line is disconnected. Gasoline is extremely flammable and highly explosive, which could result in death or serious injury. (00275a)

2. See the service manual to perform the following steps:
  - a. Remove seat.
  - b. Purge and disconnect fuel supply line.

### ⚠ WARNING

To prevent accidental vehicle start-up, which could cause death or serious injury, remove main fuse before proceeding. (00251b)

### NOTE

- **WITH security siren:** With security fob present, turn ignition switch ON. See the service manual. Disarm security system. Turn ignition switch OFF. **IMMEDIATELY** remove main fuse.
- **WITHOUT security siren:** See the service manual. Remove main fuse.

### ALL models:

3. See the service manual to perform the following steps:
  - a. Remove instrument console (if present) from fuel tank.
  - b. Remove fuel tank.
4. Raise the motorcycle.

## Remove Engine Components

1. Remove existing air cleaner assembly. See service manual.
2. Remove existing exhaust system per the service manual.
3. Disassemble engine top end. Refer to service manual engine sections.

## Install Engine Top End Components

### NOTE

- See Figure 1. The 103.1 mm (4 in) cylinder base gasket (1) and cylinder head gasket (2) eliminate the need for O-rings. Do not use O-rings on cylinder dowels or cylinder spigots.
- When installing new base gasket (1), install with embossed side down and concave side up.

1. Refer to the service manual. Assemble the engine with the following change:
  - a. Assemble the top end of the engine using the base gaskets and head gaskets from the kit. Refer to ENGINE section of service manual.

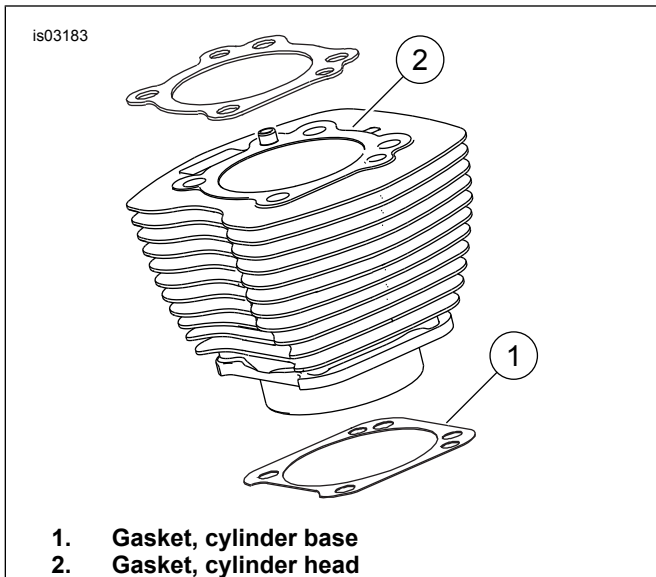

Figure 1. Cylinder Gaskets

## Final Assembly

1. Install fuel tank. See service manual.
2. Install main fuse. See service manual.
3. Install seat. After installing seat, pull up on seat to verify that it is secure. See service manual.

## SE120R PISTON

Refer to ENGINE section of service manual.

### Piston Installation

#### ⚠ WARNING

To prevent accidental vehicle start-up, which could cause death or serious injury, disconnect battery cables (negative (-) cable first) before proceeding. (00307a)

#### ⚠ WARNING

Disconnect negative (-) battery cable first. If positive (+) cable should contact ground with negative (-) cable connected, the resulting sparks can cause a battery explosion, which could result in death or serious injury. (00049a)

1. See the service manual. Remove seat. Disconnect both battery cables, negative battery cable first. Retain all seat mounting hardware.

#### ⚠ WARNING

When servicing the fuel system, do not smoke or allow open flame or sparks in the vicinity. Gasoline is extremely flammable and highly explosive, which could result in death or serious injury. (00330a)

2. Refer to the ENGINE: STRIPPING MOTORCYCLE FOR SERVICE and TOP END OVERHAUL, DISASSEMBLY sections of the service manual for cylinder head, cylinder and piston removal procedures.
3. Follow the procedures in the ENGINE: SUB-ASSEMBLY SERVICE AND REPAIR, TOP END/ CYLINDER/ UPPER CONNECTING ROD sections of the service manual for inspection of parts.
4. See the ENGINE: SUB-ASSEMBLY SERVICE AND REPAIR, CYLINDER section of the service manual for boring and honing instructions.

#### NOTE

- Install the top ring (barrel-faced) and second ring (taper-faced Napier) with the "N" marking facing up. Oil ring rails can be installed either side up.
- The 103.1 mm (4 in) cylinder base gaskets and cylinder head gaskets in the kit eliminate the need for O-rings (Part No. 11273). **Do not** use O-rings on cylinder dowels or cylinder spigots.
- When installing new base gasket, install with the embossed side down and the concave side up.

#### NOTE

Checking piston-to-cylinder fit at this location per Table 11 is for reference.

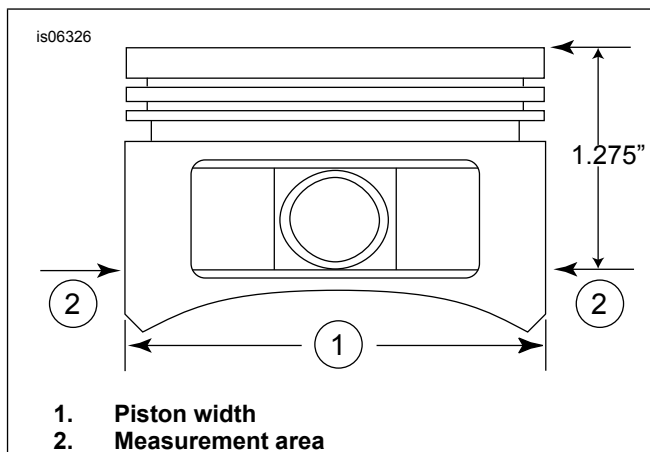

Figure 2. Piston Measurements

5. See Figure 2. Measure piston width (1), 90 degrees horizontally from both sides of the piston pin hole and 1.275 in. (32.385 mm) down from the deck (top) surface of the piston (2). See Table 11 for piston-to-cylinder fit at this location.
6. The pistons in this kit are front and rear specific. Install the piston marked "FRONT" in the front cylinder with the arrow pointing toward the **front** of the engine. Install the piston marked "REAR" in the rear cylinder with the arrow pointing toward the **front** of the engine.

- Refer to the ENGINE: TOP END OVERHAUL, ASSEMBLY section of the service manual for piston, cylinder and cylinder head installation procedures.

**Table 11. Specifications**

Piston:	Clearance (in.)
Piston-to-cylinder fit (Loose)	0.0026-0.0036
Piston pin fit (Loose)	0.0003-0.0008
Top Ring End Gap	0.012-0.020
Second Ring End Gap	0.016-0.024
Oil Control Ring Rail Gap	0.008-0.0028
Top Ring Side Clearance	0.0010-0.0022
Second Ring Side Clearance	0.0010-0.0022
Oil Control Ring Side Clearance	0.0003-0.0072

**Table 12. Service Wear Limits**

Piston-to-cylinder fit (Loose)	Wear Limit (in.)
Fit in cylinder (Loose)	0.0061
Piston Pin Fit (Loose)	0.0011
Top Ring End Gap	0.030
Second Ring End Gap	0.034
Oil Control Ring Rail Gap	0.038
Top Ring Side Clearance	0.0030
Second Ring Side Clearance	0.0030
Oil Control Ring Side Clearance	0.0079

### Piston Pin Retaining Ring (Circlip) Installation

**NOTE**

*Circlip gap must be at straight up or straight down position when installed.*

- See Figure 3. Insert the open end of the circlip (1) into the notch (2) on the groove (3) around the piston pin boss so the gap is at the straight up or straight down position when installed.
- See Figure 4. Position your thumb (1) as shown. Press firmly until approximately 85% of the circlip (2) is seated in the groove.
- Do not scratch or mar the piston. Use a small-bladed screwdriver to wedge the circlip into the rest of the groove. Repeat for the remaining circlips.

**NOTE**

*Make sure that the piston circlip is fully seated, or ENGINE DAMAGE WILL OCCUR.*

- Refer to the ENGINE: ASSEMBLING MOTORCYCLE AFTER STRIPPING section of the service manual for final reassembly procedures.

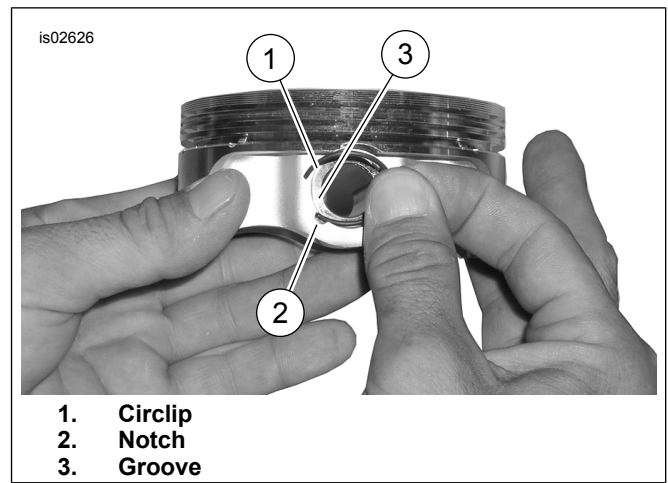

**Figure 3. Circlip and Piston**

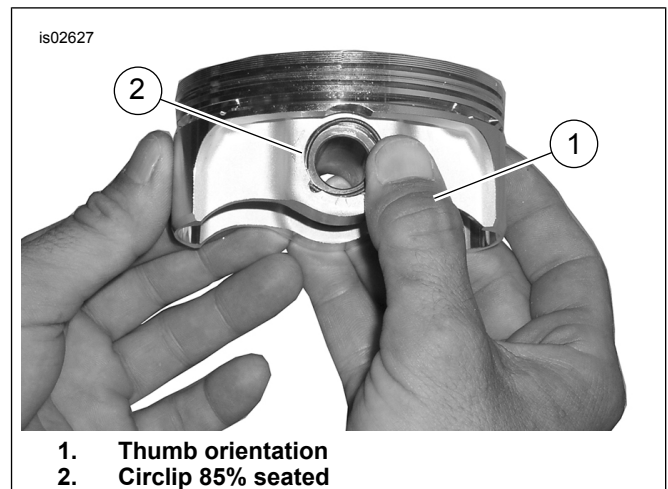

**Figure 4. Install Circlip**

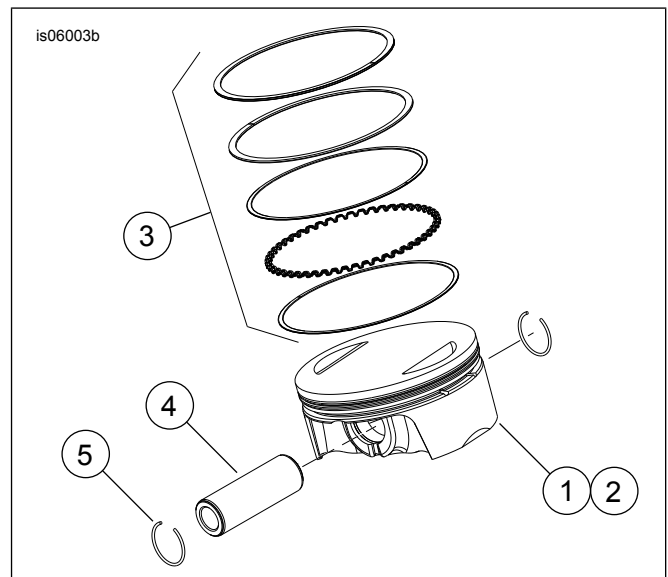

**Figure 5. Piston Assembly**

**Table 13. Piston Assembly**

Item	Description (Quantity)
1	Piston (front, standard)
2	Piston (rear, standard)
3	• Ring set, standard (2)

**Table 13. Piston Assembly**

Item	Description (Quantity)
4	• Piston pin (2)
5	• Circlip (4)
1	Piston (front, +0.010)
2	Piston (rear, +0.010)
3	• Ring set, +0.010 (2)
4	• Piston pin (2)
5	• Circlip (4)

## REPLACING/SERVICING PUSHRODS

1. Refer to ENGINE section of service manual.

### NOTE

Follow service manual procedures for installing or removing pushrods. Pushrods are marked "INT" (intake) and "EXH" (exhaust).

The pushrods are directional. Verify that the larger ends of the pushrods are installed down in the lifter sockets.

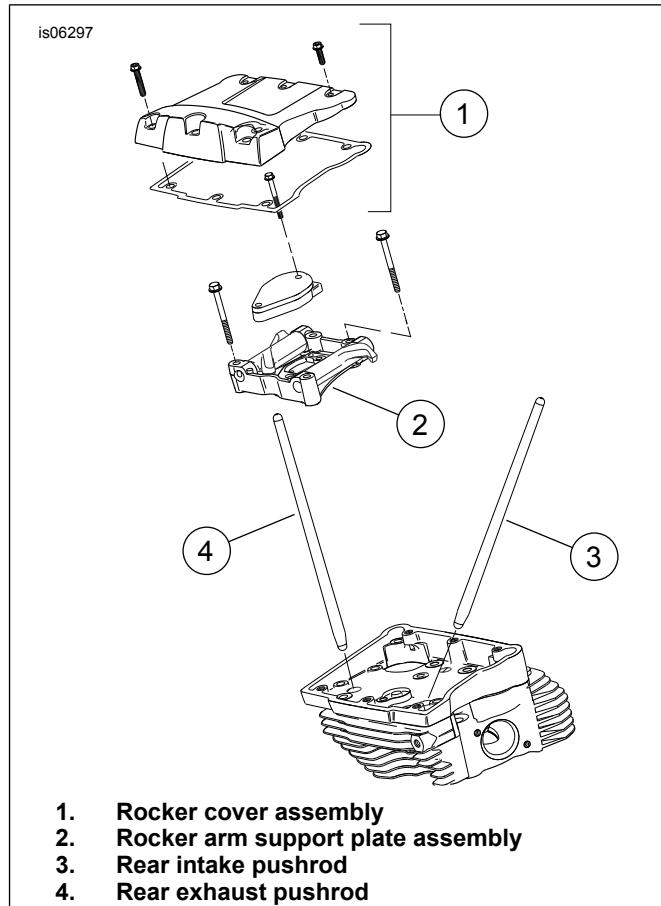

**Figure 6. Push Rods**

# SERVICE PARTS

is07076a

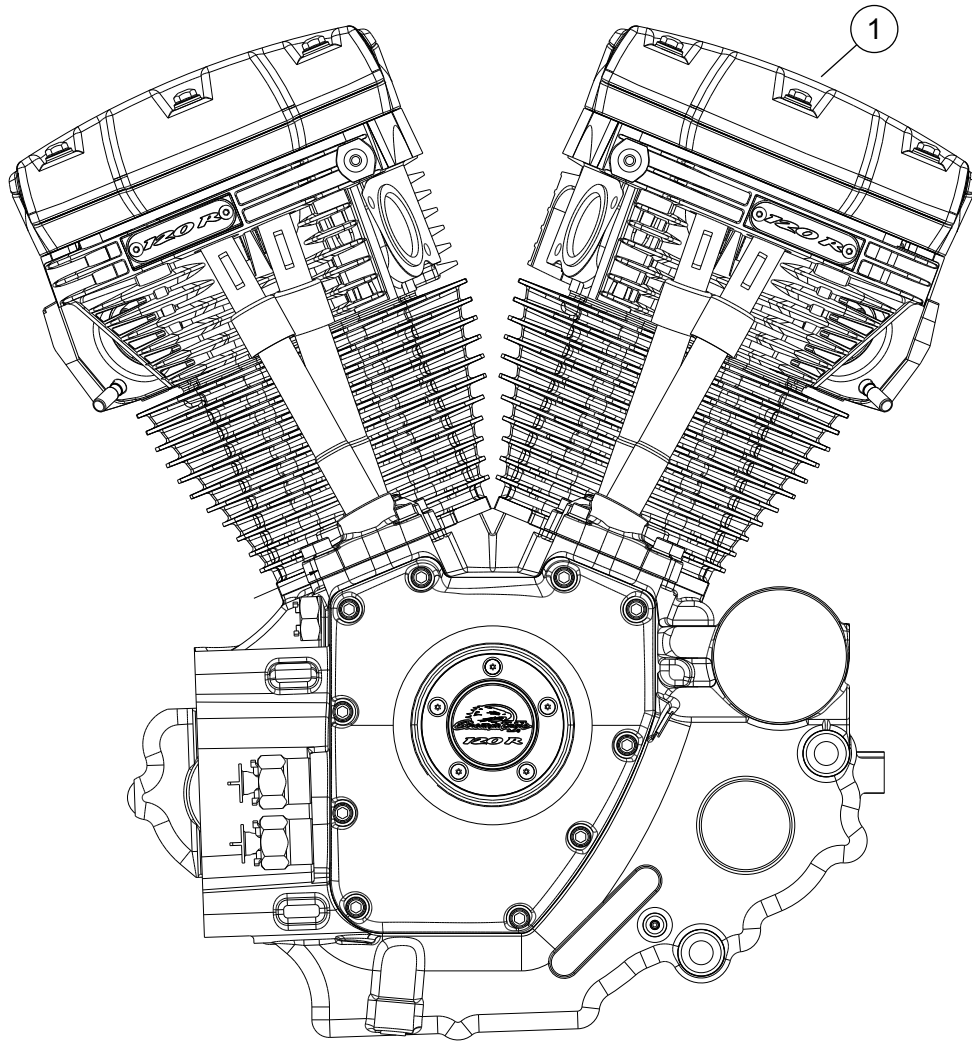

Figure 7. Engine Assembly, Screamin' Eagle Pro 120R Crate Engine (Beta) Complete

Table 14. Service Parts, Screamin' Eagle Pro 120R Crate Engine (Beta)

Item	Description (Quantity)	Part Number
1	Engine assembly, complete	19206-16

## SERVICE PARTS

is06380c

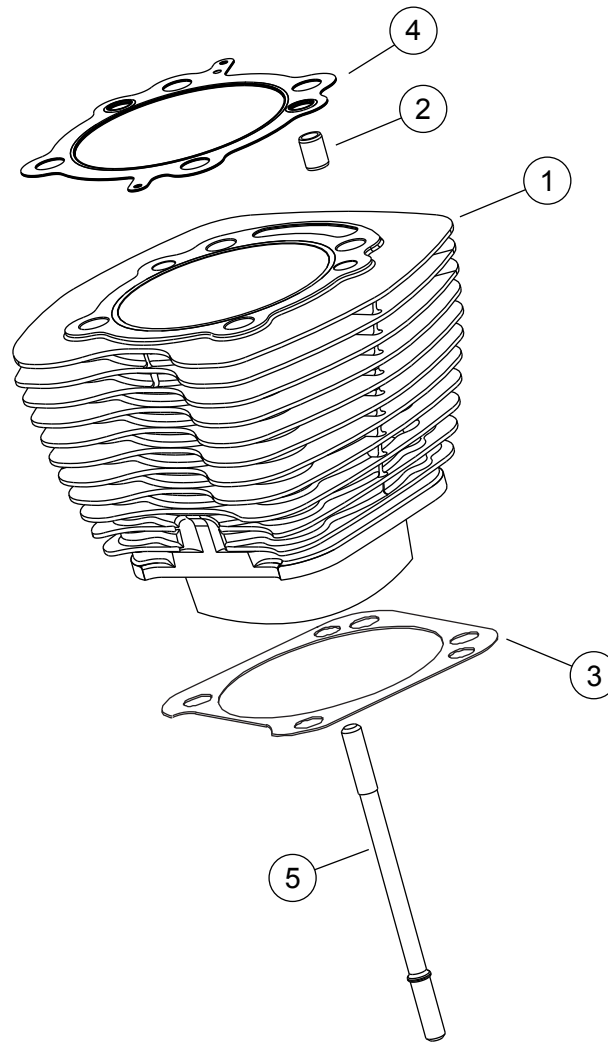

Figure 8. SE120R Screamin' Eagle Pro Crate Engine (Beta) Cylinders

Table 15. Service Parts, SE120R Screamin' Eagle Pro Crate Engine (Beta) Cylinders

Item	Description (Quantity)	Part Number
1	SE cylinder kit, 103.1 mm (4 in) (black). Includes front and rear cylinders, items 2-4, flanged hex head screw (Part No. 1105) and sealing washer (Part No. 1086A).	16550-04C
2	• Dowel pin, ring (4)	16595-99A
3	• Gasket, cylinder base (2)	16736-04A
4	• Gasket, cylinder head (2)	16104-04
5	Stud, cylinder (8)	16834-99A
6	Gasket kit, engine overhaul (not shown). <b>DOES NOT include</b> cylinder head gasket, base gasket or valve stem seals.	17053-99C
7	Gasket kit, top-end (not shown). <b>DOES NOT include</b> cylinder head gasket, base gasket or valve stem seals.	17052-99C



## SERVICE PARTS

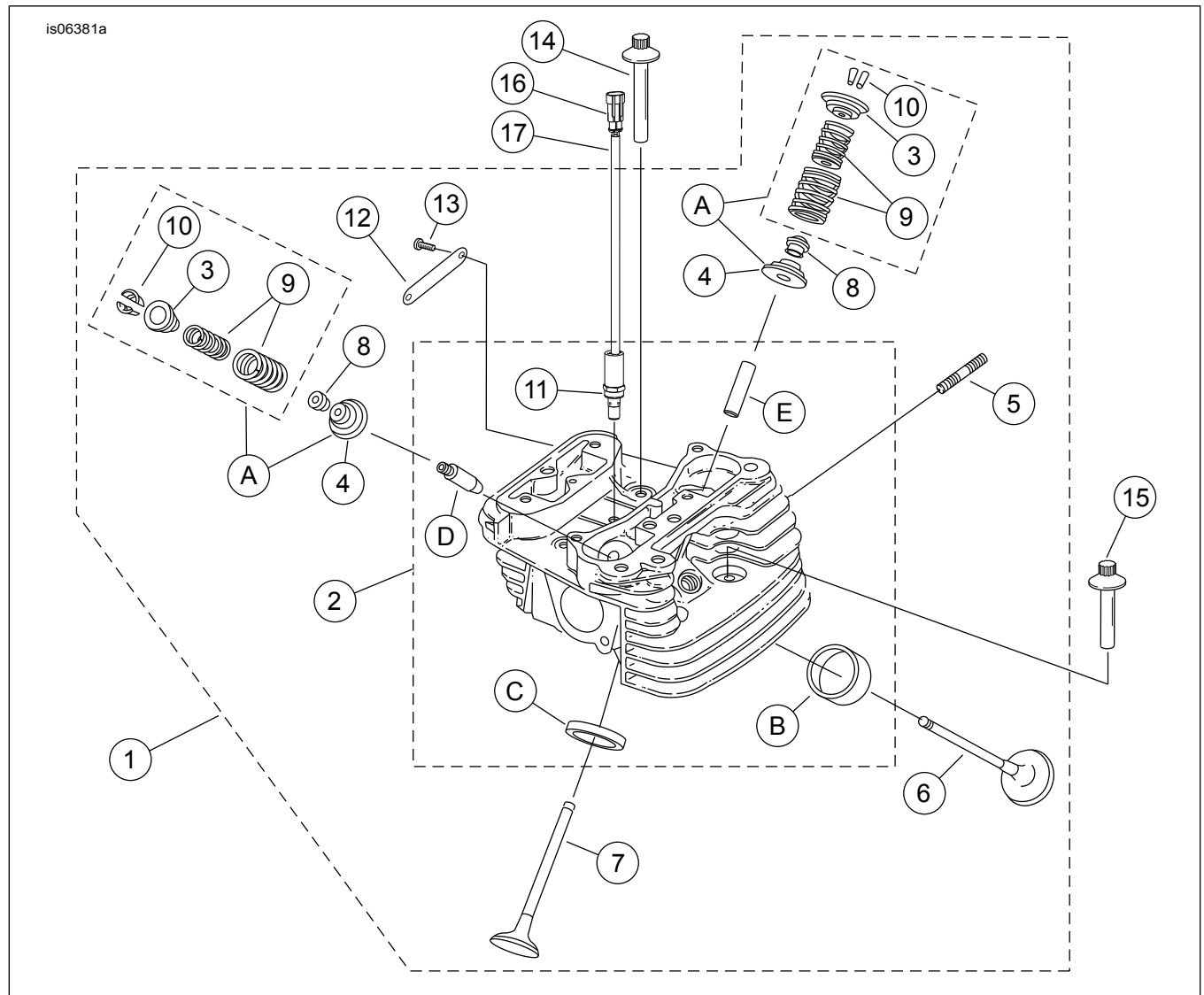

Figure 9. SE120R Screamin' Eagle Pro Crate Engine (Beta) Cylinder Heads and Valves

## SERVICE PARTS

Table 16. Service Parts, SE120R Screamin' Eagle Pro Crate Engine (Beta) Cylinder Heads and Valves

Item	Description (Quantity)	Part Number
1	Cylinder head assembly, rear (includes Items 2-13) Cylinder head assembly, front (includes Items 2-13)	17444-10 17443-10
2	• Cylinder head (machined, with items 11, B, C, D and E installed)	Not sold separately
3	• Collar, valve spring, upper (4). Included with Item "A".	Not sold separately
4	• Collar, valve spring, lower (4). Included with Item "A".	Not sold separately
5	• Stud, exhaust port (4)	16715-83
6	• Intake valve (2)	18190-08
7	• Exhaust valve (2)	18183-03
8	• Seal, valve (4)	18046-98
9	• Valve spring unit (4). Included with Item "A"	Not sold separately
10	• Retainer, valve collar (8). Also included with Item "A"	18240-98
11	• Solenoid, automatic compression release (ACR) (2)	28861-07A

**Table 16. Service Parts, SE120R Screamin' Eagle Pro Crate Engine (Beta) Cylinder Heads and Valves**

<b>Item</b>	<b>Description (Quantity)</b>	<b>Part Number</b>
12	• Medallion, "120R" (2)	17136-10
13	• Screw, button head, TORX (4)	25800017
14	Screw, internal thread, 81 mm (3 in) long (4)	16478-85A
15	Screw, internal thread, 47.6 mm (2 in) long (4)	16480-92A
16	Pin housing, two-way	72009-05
17	Wire seal, 16-20 AWG (4)	72011-05
18	Spark plug, Screamin' Eagle (2) (not shown)	32186-10
<b>Service Kits:</b>		
A	Valve Spring Kit, Screamin' Eagle	18281-02A
<b>The following Screamin' Eagle parts are available separately:</b>		
B	Seat, intake valve	18191-08
C	Seat, exhaust valve	18048-98A
D	Valve guide, intake (for service)	
	• (+ 0.003 in.)	18158-05
	• (+ 0.002 in.)	18156-05
	• (+ 0.001 in.)	18154-05
E	Valve guide, exhaust (for service)	
	• (+ 0.003 in.)	18157-05
	• (+ 0.002 in.)	18155-05
	• (+ 0.001 in.)	18153-05

# SERVICE PARTS

is06384c

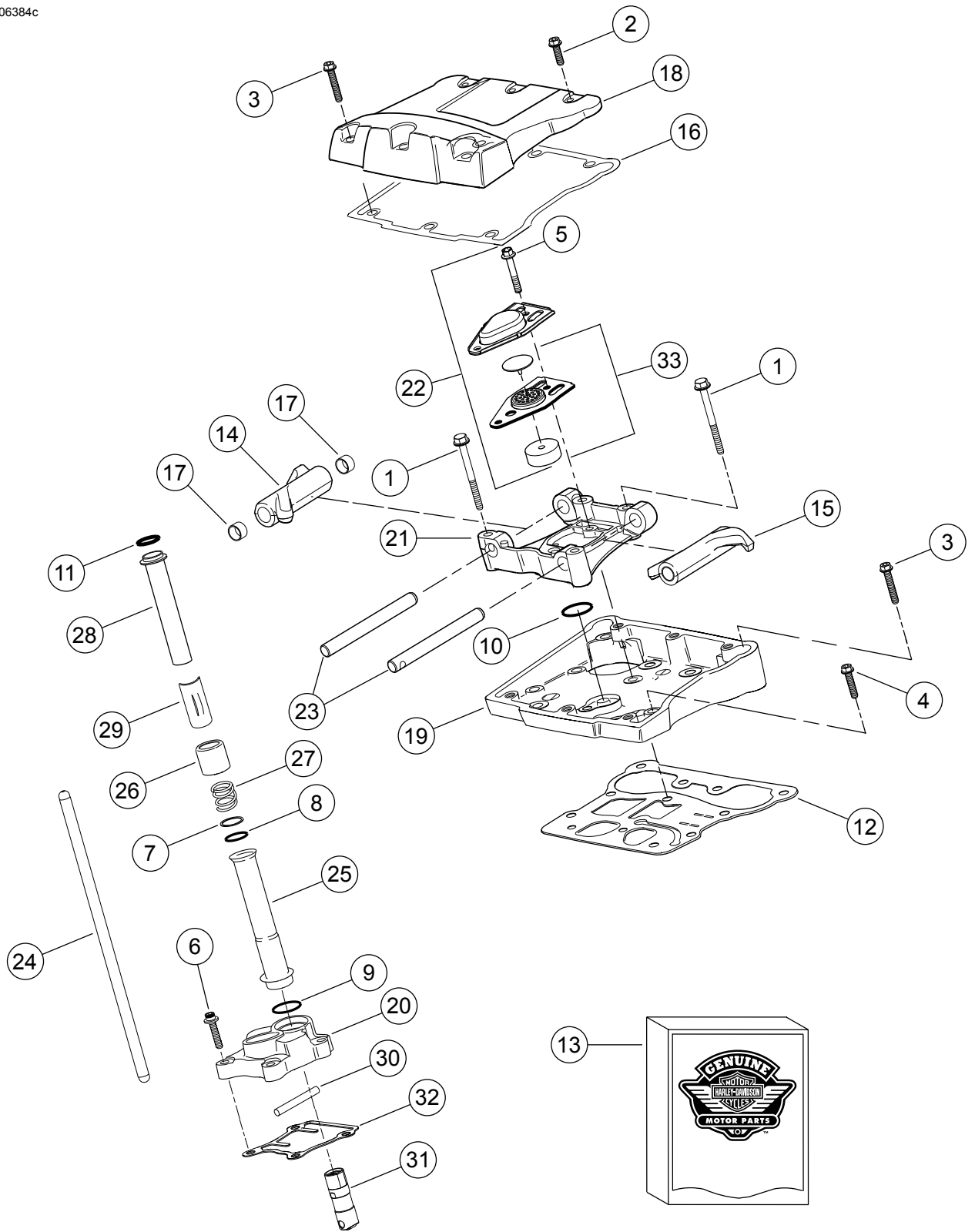

Figure 10. SE120R Screamin' Eagle Pro Crate Engine (Beta) Rocker Arms and Push Rods

## SERVICE PARTS

Table 17. Service Parts, SE120R Screamin' Eagle Pro Crate Engine (Beta) Rocker Arms and Push Rods

Item	Description (Quantity)	Part Number
1	Cap screw, hex flanged head, 5/16-18 x 63.5 mm (2½ in), Grade 8 with lock patch (8)	1039
2	Screw, internal/external hex flanged head, 5/16-18 x 25.4 mm (1 in), with lock patch (6)	3692A
3	Screw, internal/external hex flanged head, 5/16-18 x 44.4 mm (1½ in), with lock patch (10)	3693A
4	Screw, hex flanged head SEMS, 5/16-18 x 31.8 mm (1½ in), with lock patch (8)	3736B
5	Screw, hex flanged head, 1/4-20 x 42.9 mm (1½ in), Grade 8, with lock patch, (4)	4400
6	Cap screw, hex socket head, heat treated washer, 1/4-20 x 25.4 mm (1 in), lock patch (6)	4741A
7	Washer, 0.79 mm (0 in) thick (4)	6762B
8*	O-ring, push rod cover, 17 mm (½ in) ID, brown (4)	11132A
9*	O-ring, push rod cover, 22 mm (1 in) ID, brown (4)	11145A
10*	O-ring, 15.5 mm (½ in) ID, black (2)	11270
11*	O-ring, 17 mm (½ in) ID, yellow (4)	11293
12	Gasket, rocker housing (2)	16719-99B
13	Gasket kit, cam service (contains items marked "**")	17045-99D
14	Rocker arm (front intake, rear exhaust), with bushings (2)	17360-83A
15	Rocker arm (rear intake, front exhaust), with bushings (2)	17375-83A
16*	Gasket, rocker cover (2)	17386-99A
17	Bushing, rocker arm (8)	17428-57
18	Rocker cover, (chrome) (2)	17572-99
19	Rocker housing, (chrome) (2)	17578-10
20	Lifter cover, front (chrome) Lifter cover, rear (chrome)	17964-99 17966-99
21	Support, rocker arm (2)	17594-99
22*	Breather assembly (2). Includes Items 5 and 33.	17025-03A
23	Shaft, rocker arm (4)	17611-83
24	Perfect Fit push rod kit (+0.030 inch)	18401-03
25	Cover, push rod, lower (4)	17939-99
26	Cap, cover spring (4)	17945-36B
27	Spring, push rod cover (4)	17947-36
28	Cover, push rod upper (4)	17948-99
29	Keeper, spring cover (4)	17968-99
30	Pin, anti-rotation (2)	18535-99
31	Screamin' Eagle High Capacity Lifter Kit (includes 4)	18572-13
32	Gasket, tappet cover (2)	18635-99B
33	Baffle assembly, breather, with breather valve and filter (2)	26500002

## SERVICE PARTS

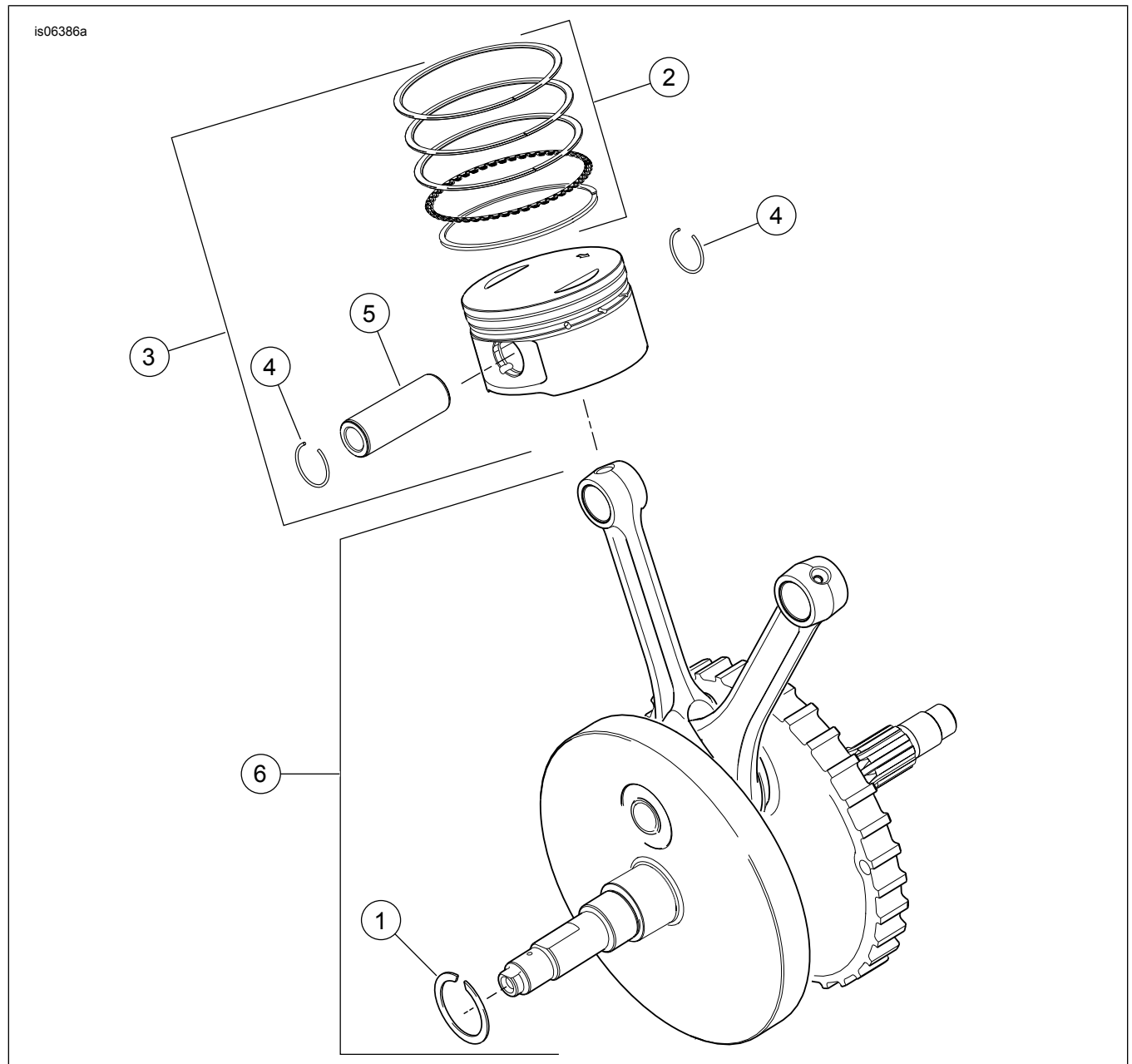

Figure 11. SE120R Screamin' Eagle Pro Crate Engine (Beta) Pistons and Flywheel

Table 18. Service Parts, SE120R Screamin' Eagle Pro Crate Engine (Beta) Pistons and Flywheel

Item	Description (Quantity)	Part Number
1	Retaining ring	11177A
2	Piston ring set, standard (2)	22526-10
	Piston ring set, 0.254 mm (0 in) over size (2)	22529-10
3	Piston kit, front and rear, with ring sets, piston pin and lock rings, standard	22574-10
	Piston kit, front and rear, with ring sets, piston pin and lock rings, 0.254 mm (0 in) over size	22576-10
4	Lock ring, piston pin (4)	22097-99
5	Piston pin (2)	22310-10
6	Flywheel assembly kit (4-5/8 in stroker)	2410004A

## SERVICE PARTS

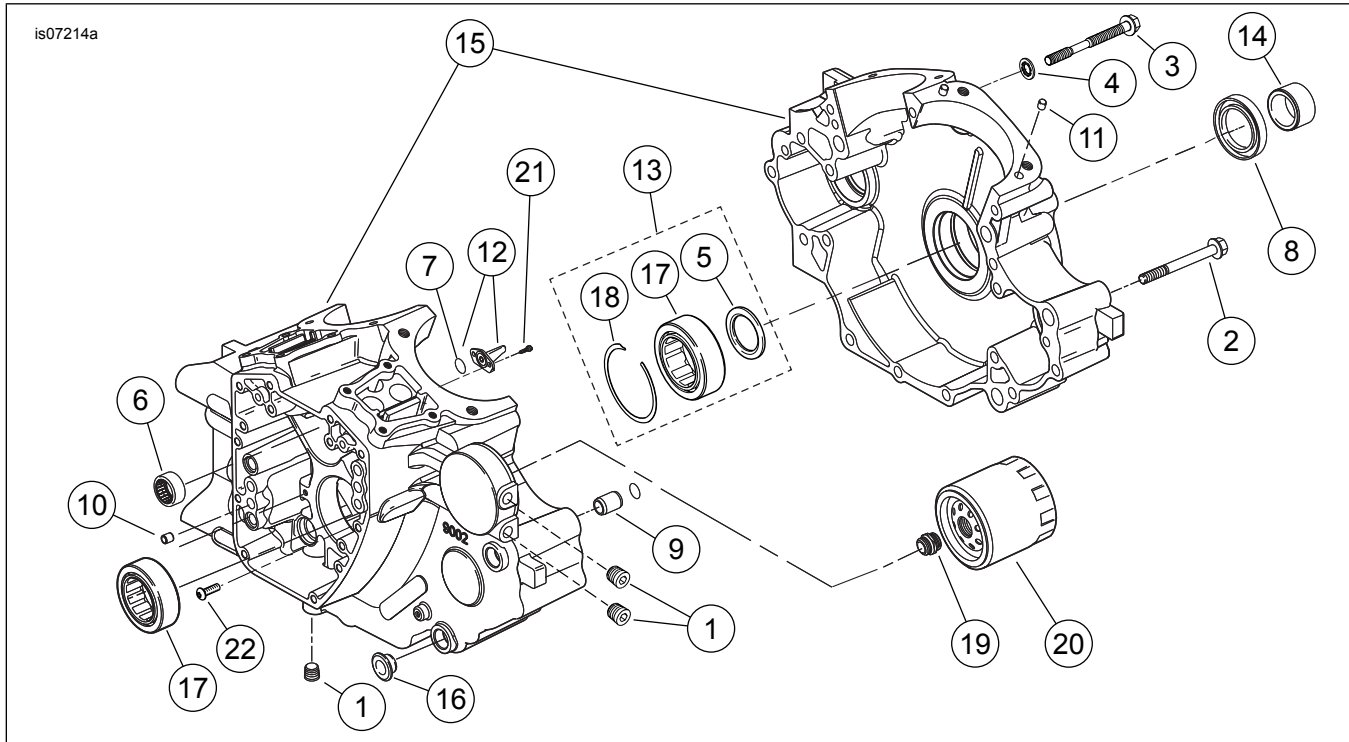

Figure 12. SE120R Screamin' Eagle Pro Crate Engine (Beta) Crankcase, Engine Oil Filter and Cooler

Table 19. Service Parts, SE120R Screamin' Eagle Pro Crate Engine (Beta) Crankcase, Engine Oil Filter and Cooler

Item	Description (Quantity)	Part Number
1	Plug (3)	765
2	Screw, hex flange head, 5/16-18 x 76 mm (3 in) long (11)	895
3	Screw, crankcase top center	1105
4	Sealing washer	1086A
5	Washer, 32 mm (1½ in) ID, 46 mm (2 in) OD, 3.2 mm (0 in) thick (2)	8972
6	Needle bearing kit, camshaft (2) (Each kit includes two bearing assemblies)	24018-10
7	O-ring (2)	10930
8	Oil seal	12068
9	Dowel pin, 14.158 mm (½ in) D x 19 mm (½ in) long (2)	16574-99A
10	Dowel pin, 9.525 mm (½ in) D x 10.16 mm (½ in) long (2)	16589-99A
11	Dowel pin, 11.074 mm (½ in) D x 15.5 mm (½ in) long (4)	16595-99A
12	Piston cooling jet (2) (includes Item 7)	22315-06A
13	Bearing kit, left side [includes items 5 and 18, one bearing (17) and the bearing inner race]	24004-03B
14	Spacer, sprocket shaft	24009-06
15	Crankcase set, (black) with bearings, cooling jets and bolts	24400001A
16	Spacer (4)	24603-00
17	Bearing, main (2)	24605-07
18	Retaining ring	35114-02
19	Adapter, oil filter	26352-95A
20	Oil filter (chrome)	63798-99A
21	Screw, TORX® head, 8-32 x 9.5 mm (½ in) long (4)	68042-99
22	Screw, bearing retention, TORX® button head, 1/4-20 x 11.1 mm (½ in) long (2)	703B

## SERVICE PARTS

is07218a

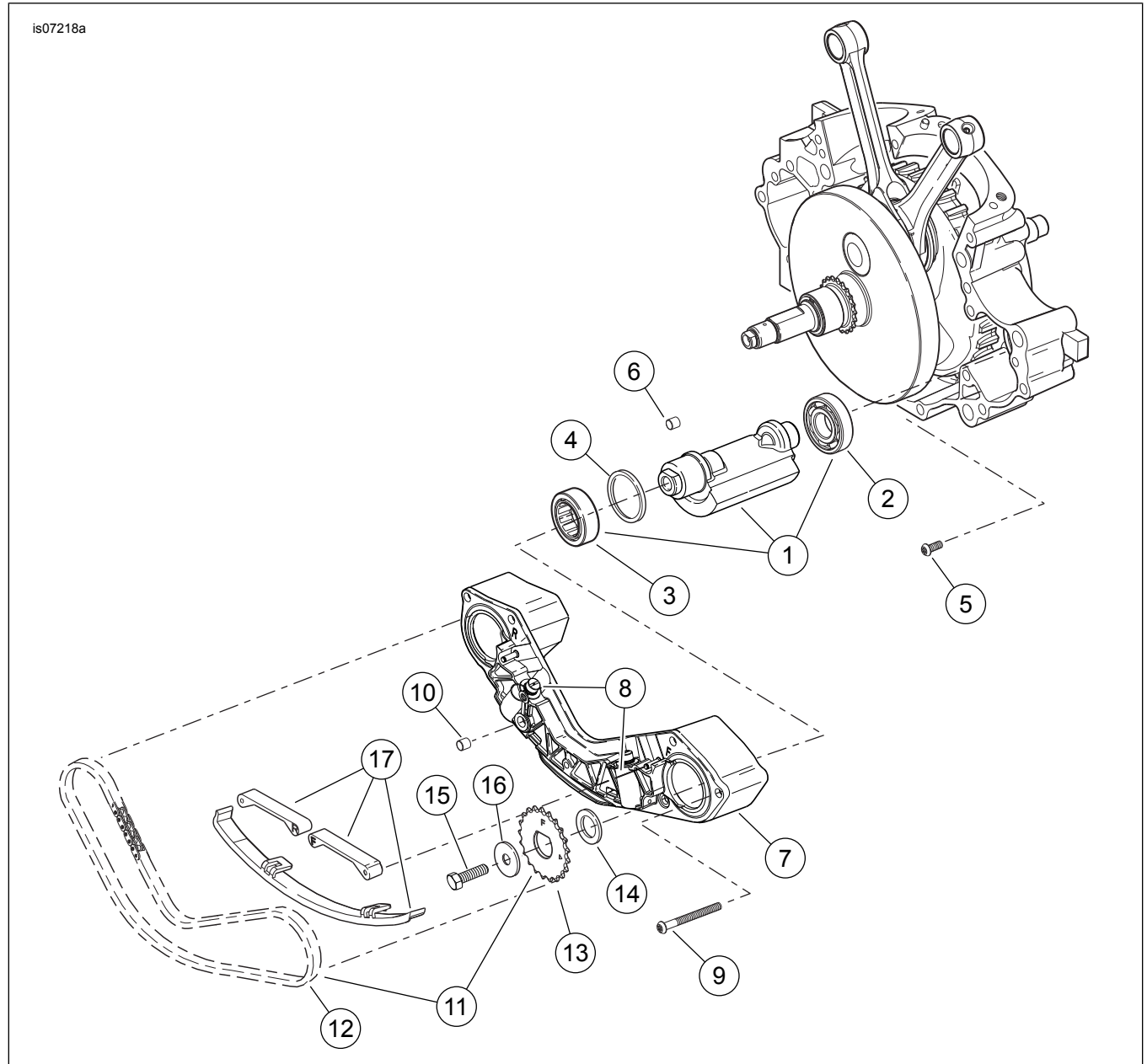

Figure 13. Service Parts: SE120R Screamin' Eagle Pro Crate Engine (Beta) Engine Balancer

## SERVICE PARTS

Table 20. Service Parts, SE120R Screamin' Eagle Pro Crate Engine (Beta) Engine Balancer

Item	Description (Quantity)	Part Number
1	Balance shaft kit (2). Includes Items 2-3	14789-07
2	• Bearing	8992A
3	• Bearing, shell	8959
4	Retaining ring, balance shaft bearing (2)	35240-07
5	Screw (2)	703B
6	Bushing, dowel (2)	16583-00A
7	Support assembly, chain guide. Includes Item 8	14728-07
8	• Piston assembly kit, chain tensioner (2)	14764-00
9	Screw (6)	956
10	Seal, oil interconnect	45359-00
11	Chain drive kit. Includes Items 12-13.	14762-00

**Table 20. Service Parts, SE120R Screamin' Eagle Pro Crate Engine (Beta) Engine Balancer**

Item	Description (Quantity)	Part Number
12	• Chain, balancer drive (Timing chain assembly)	14769-00
13	<ul style="list-style-type: none"> <li>• Sprocket, balance shaft, front (shown, marked "F")</li> <li>• Sprocket, balance shaft, rear (not shown, marked "R")</li> </ul>	Not sold separately Not sold separately
14	Spacer, 0.99 mm (0 in) thick. Behind <b>front</b> sprocket.	14784-07
15	Bolt, balance shaft (2)	3110
16	Washer, balance shaft bolt (2)	6456
17	Guide kit, chain tensioner, includes front, rear and lower guides	14762-00



# SERVICE PARTS

1961924

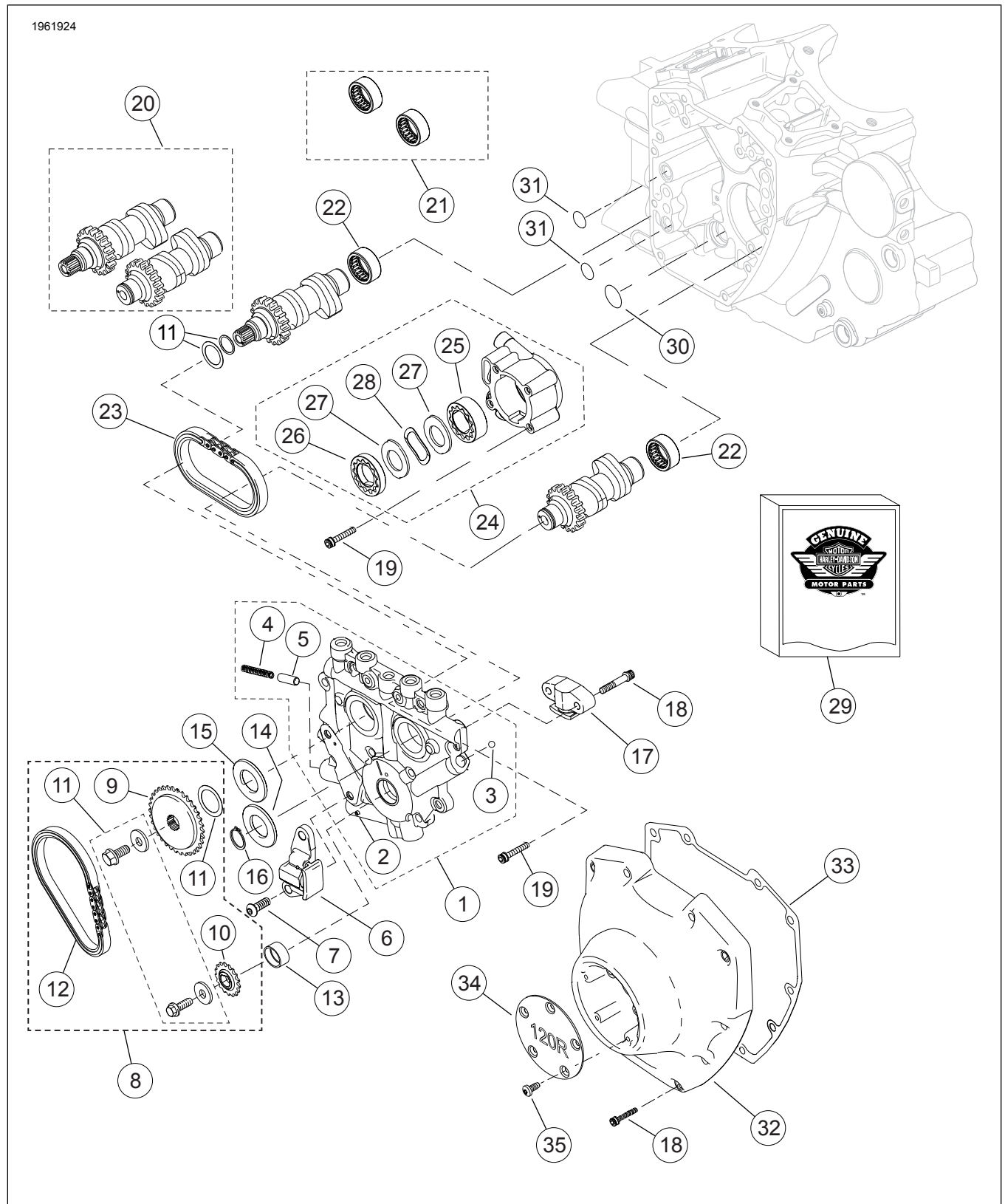

Figure 14. SE120R Screamin' Eagle Pro Crate Engine (Beta) Camshafts and Camshaft Cover

## SERVICE PARTS

Table 21. Service Parts, SE120R Screamin' Eagle Pro Crate Engine (Beta) Camshafts and Camshaft Cover

Item	Description (Quantity)	Part Number
1	Cam support plate assembly (includes items 2-5)	25400019
2	• Roll pin	601
3	• Ball (12) (only 1 serviceable)	8873
4	• Spring, relief valve	26210-99
5	• Relief valve, oil pump	26400-82B
6	Chain tensioner, primary cam drive chain	39968-06
7	Screw, primary cam chain tensioner (2)	942
8	Camshaft chain and fastener kit (includes items 9-12)	25585-06
9	• Sprocket, cam drive, 34 T	25728-06
10	• Sprocket, cam drive (on crankshaft), 17 T	25673-06
11	• Cam drive sprocket retention kit	91800088
12	• Chain, primary cam drive	25675-06
13	Bushing, crankshaft	Not sold separately
14	Spacer, cam drive sprocket alignment, 2.54 mm (0.100 in) thick	25729-06
15	Spacer, cam drive sprocket alignment, 2.54 mm (0.100 in) thick (use as required)	25729-06
	Spacer, cam drive sprocket alignment, 2.79 mm (0.110 in) thick (use as required)	25731-06
	Spacer, cam drive sprocket alignment, 3.05 mm (0.120 in) thick (use as required)	25734-06
	Spacer, cam drive sprocket alignment, 3.3 mm (0.130 in) thick (use as required)	25736-06
	Spacer, cam drive sprocket alignment, 3.56 mm (0.140 in) thick (use as required)	25737-06
	Spacer, cam drive sprocket alignment, 3.81 mm (0.150 in) thick (use as required)	25738-06
16	Retaining ring	11461
17	Chain tensioner, secondary cam drive chain	39969-06
18	Screw, secondary cam tensioner (2)	4740A
	Screw, cam cover (10)	4740A
	1/4-20 x 31.8 mm (1.25 in) long, Grade 8, knurled, with lockpatch	
19	Screw, socket head, 1/4-20 x 25.4 mm (1.0 in) long, with lockpatch (10)	4741A
20	Camshaft kit, front and rear, SE266E	25494-10
21	Needle bearing kit, camshaft (includes two of Item 22)	24018-10
22	• Bearing, needle, full complement (2)	Not sold separately
23	Chain, secondary cam drive	25683-06
24	Oil pump assembly (includes items 25-28)	26037-06
25	• Gerotor assembly, scavenge	26278-06
26	• Gerotor assembly, pressure	26281-06
27	• Separator plate, gerotor (2)	26282-06
28	• Spring, separator	40323-00
29	Gasket kit, cam service (contains Item 31 and items marked "*" in Table 16)	17045-99D
30	• O-ring, 17 mm(0.671) ID, yellow	11293
31	O-ring, 9.2 mm (0.362 in) ID, brown (2)	11301
32	Cam cover, (chrome)	25369-01B
33	Gasket, cam cover	25244-99A
34	Cover, timer, "120R"	25495-10
35	Screw, TORX head, 8-32 x 0.375 in long (5)	68042-99