

TOURING MODELS

2010 HARLEY-DAVIDSON® OWNER'S MANUAL



Harley-Davidson Motor Company
Service Communications
Milwaukee WI 53208 USA

2025-01-31

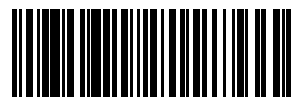

99466-101

English

Printed in the USA

2010 HARLEY-DAVIDSON® OWNER'S MANUAL
TOURING MODELS - 99466-101



99466-101

HARLEY-DAVIDSON

TOURING MODELS

2010 HARLEY-DAVIDSON® OWNER'S MANUAL



99466-101

2010 HARLEY-DAVIDSON® OWNER'S MANUAL - TOURING MODELS

TABLE OF CONTENTS

INTRODUCTION

Safety Definitions.....	1
Your Owner's Manual.....	1
We Care About You.....	1
United States Owners.....	2
Customer Service Assistance.....	2

SAFETY FIRST

Safe Operating Rules.....	5
Additional Safe Operating Rules.....	11
Rules of the Road.....	11
Accessories and Cargo.....	12
Accessory and Cargo Guidelines.....	13
Noise Control System.....	14
Tampering.....	14

IDENTIFICATION

Vehicle Identification Number (V.I.N.).....	15
General.....	15
Location.....	15
Abbreviated V.I.N.....	15
Labels.....	18

SPECIFICATIONS

Specifications.....	21
---------------------	----

Tire Data.....	27
Gasoline Blends.....	28
Fuel.....	29
Catalytic Converter.....	29

CONTROLS AND INDICATORS

General: Controls and Indicators.....	31
Ignition/Headlamp Key Switch.....	31
Fork Lock.....	34
To Lock Fork on FLHR/FLHRC Models.....	34
To Lock Fork on Other Models.....	34
Hand Controls: Basic Operation.....	35
Electric Starter Switch.....	35
Engine OFF/RUN Switch.....	35
Throttle Control Grip.....	36
Clutch Hand Lever.....	36
Horn Switch.....	37
Headlamp Dimmer Switch.....	37
Turn Signal Switches.....	37
Audio/CB Control Switches.....	37
Cruise Control Switches.....	37
HEATED HAND GRIPS.....	39
Electronic Throttle Control (ETC).....	39
ETC Limited Performance Mode.....	40
ETC Power Management Mode.....	40
ETC Forced Idle Mode.....	40

TABLE OF CONTENTS

ETC Forced Shutdown Mode.....	40	Theory of Operation.....	51
Turn Signal Switch Operation.....	40	Engaging Cruise Control.....	52
Hazard Warning 4-Way Flasher.....	40	Disengaging Cruise Control.....	52
INDICATOR LAMPS.....	41	Resuming Cruise Speed.....	53
Instruments.....	42	Accelerating Above Cruise Speed.....	53
Speedometer.....	42	Decelerating Cruise Control.....	53
Setting Clock.....	43	Deactivating Cruise Control.....	53
Tachometer.....	44	Gear Shift Lever.....	54
Tip Indicator Lamp.....	44	Heel-Toe Foot Shifter.....	55
Fuel Gauge.....	44	Brake System.....	55
Oil Pressure Gauge.....	44	General.....	55
Voltmeter.....	44	Non-ABS Brake System.....	56
Air Temperature Gauge.....	45	Anti-lock Brake System (ABS).....	56
Fuel Range Function.....	45	ABS: How It Works.....	56
Instrument Lamps.....	46	ABS: How To Use.....	56
Engine Check Lamp.....	46	ABS: Tires and Wheels.....	57
Low Fuel Lamp.....	47	Jiffy Stand.....	58
Battery Discharge Lamp.....	47	Jiffy Stand Interlock: International Models.....	59
Cruise Control Equipped Models.....	47	Rear View Mirrors.....	59
Sixth Gear Lamp.....	47	Fuel Filler Cap.....	60
Security System Lamp.....	47	Rear Air Suspension.....	61
ABS Lamp.....	47	Luggage.....	65
Cruise Control.....	50	TOUR-PAK.....	65
Operating Controls.....	50	Operation.....	65
Cruise Control Operation.....	51	Removal/Installation.....	66

TABLE OF CONTENTS

Leather Saddlebags.....	67	Stereo Receiver.....	78
Opening.....	67	Front Panel Controls.....	79
Closing.....	67	ON.....	79
Hard Saddlebags.....	67	1, 2, 3, 4, 5/Left Arrow.....	79
Opening.....	67	6.....	79
Closing.....	68	5/Left, Up, Down, Right Arrows.....	80
Removing.....	68	OK.....	80
Installing.....	68	COM.....	80
Adjustments.....	68	INT.....	80
Windshield: FLHR/C.....	71	NAV.....	80
Removal.....	71	LCD.....	80
Installation.....	71	CD Door.....	80
Adjustable Air Deflectors.....	71	EJECT.....	80
Cigarette Lighter.....	72	AUX.....	81
Accessory Switch.....	73	Left Handlebar Controls.....	83
Auxiliary Lamps.....	75	+/AUDIO/- Switch.....	83
Fairing Lower Vents.....	75	PTT and +/SQ/- Switch.....	83
Passenger Footboards/Footrests.....	75	Right Handlebar Controls.....	84
ADVANCED AUDIO SYSTEM		UP/MODE SEL/DN Switch.....	85
ADVANCED AUDIO SYSTEM.....	77	Receiver Operation.....	86
Audio System Quick Start Guide.....	77	Set Time-of-Day.....	87
Radio Receiver.....	77	Turn Receiver ON/OFF.....	87
Compact Disc (CD) Player.....	78	Select a Frequency Band.....	87
Intercom - If Equipped.....	78	Volume.....	87
Citizen Band (CB) Radio - If Equipped.....	78	AM vs FM Reception.....	87
		AM.....	87

TABLE OF CONTENTS

FM.....	88	Headsets and Sockets.....	98
FM Stereo vs FM Mono.....	88	VOX Microphones.....	99
WB.....	88	Speaker Controls.....	99
Tuning a Radio Station.....	88	SPKR Switch.....	99
Manual Tuning.....	88	Rider to Passenger Speaker Balance.....	100
SEEK Tuning.....	89	Passenger Controls.....	101
SCAN Tuning.....	89	UP/MODE SEL/DN Switch.....	101
Preset Memory Tuning.....	89	PTT and +/VOL/- Switch.....	101
Preset SCAN Tuning.....	90	Sidecar Controls.....	103
Adjusting Volume.....	90	MODE and +/TUNE/- Switch.....	103
Mixing Bass and Treble.....	90	PTT/+/VOL/-.....	103
Adjusting AVC.....	91	Intercom Operation.....	104
Adjusting Display Contrast.....	93	Operation.....	104
CD/MP3 Operation.....	93	Activating the Intercom and the VOX Microphones.....	104
Auto Load.....	94	Adjusting VOX Sensitivity.....	105
Disc Error 1.....	94	Adjusting Rider Headset Volume.....	105
Eject.....	95	Adjusting Passenger Headset Volume.....	106
Tracks.....	95	CB Operation.....	106
Fast Advance and Reverse.....	95	Activating the CB.....	106
Random.....	96	Entering CB Setup.....	106
Scan.....	96	Selecting a Channel.....	107
Repeat.....	96	Preset Channels.....	107
MP3.....	96	Adjusting Squelch.....	107
Recommendations for Handling CDs.....	97	Transmitting.....	108
Intercom and Citizen Band with Passenger Speakers.....	97	Adjusting Volume.....	108

TABLE OF CONTENTS

CB Range.....	108
Audio Routing and Mixing.....	110
General.....	110
Troubleshooting.....	112
Operational Troubleshooting.....	112
Radio Fuses.....	112

HANDS-FREE SECURITY MODULE

HARLEY-DAVIDSON SMART SECURITY SYSTEM.....	115
Components.....	115
Options.....	115
FCC Regulations.....	116
Hands-Free Fob.....	116
Fob Assignment.....	116
Riding with a Fob.....	117
Personal Identification Number (PIN).....	118
Changing the PIN.....	118
Security Status Indicator.....	120
Arming and Disarming.....	121
Arming.....	121
Disarming.....	121
Disarming with a PIN.....	121
Arming with Hazard Warning 4-Way Flashers On.....	123
Alarm.....	123
Warnings.....	123
The Alarm.....	124

Deactivate the Alarm.....	125
Siren Chirp Mode (Confirmation).....	125
Chirpless Mode.....	125
Chirp Mode.....	125
Switching Modes.....	125
Transport Mode.....	125
To Enter Transport Mode.....	125
To Exit Transport Mode.....	126
Storage and Service Departments.....	126
Long-Term Parking.....	126
Service Departments.....	126
Sidecar Configuration.....	126
Fob Battery.....	127
Replacing the Battery.....	127
Disconnecting Power.....	128
Optional Siren.....	128
Troubleshooting.....	128
Key Icon.....	128
Fob.....	128
Siren.....	128

OPERATION

Operating Recommendations.....	131
Break-in Riding Rules.....	132
The First 500 Miles (800 Kilometers).....	132
Pre-Riding Checklist.....	133

TABLE OF CONTENTS

Starting the Engine.....	134	Check Lubricant Level.....	148
General.....	134	Changing Transmission Fluid.....	150
Starting.....	134	Primary Chaincase Lubricant.....	151
Automatic Compression Release (ACR).....	135	General.....	151
Engine Idle Temperature Management System.....	136	Check Lubricant Level.....	151
Operation.....	136	Changing Chaincase Lubricant.....	153
Enabling/Disabling EITMS.....	136	Checking Drive Belt Deflection.....	154
Stopping the Engine.....	137	Chassis Lubrication.....	155
Shifting Gears.....	137	Miscellaneous Lubrication.....	156
Getting Started.....	137	Hinges, Latches, Etc.....	156
Upshift (Acceleration).....	138	Oil Applications.....	156
Downshift (Deceleration).....	138	Front Fork Oil.....	156
		Fuel Filter.....	156
MAINTENANCE AND LUBRICATION		CLUTCH.....	157
Safe Operating Maintenance.....	141	Hydraulic Lifters.....	157
Break-in Maintenance.....	141	Front Fork Bearings.....	157
Engine Lubrication.....	142	Rear Fork Pivot Shaft.....	158
Checking Oil Level.....	142	BRAKES.....	158
Oil Level Cold Check.....	143	Tires.....	160
Oil Level Hot Check.....	143	Tire Replacement.....	162
Changing Oil and Oil Filter.....	145	Inspection.....	162
Winter Lubrication.....	147	When To Replace Tires.....	162
OIL COOLER.....	148	Shock Absorbers.....	163
Transmission Lubrication.....	148	Spark Plugs.....	164
General.....	148	Ignition.....	164

TABLE OF CONTENTS

Air Cleaner.....	164	Battery.....	185
Headlamp: Single Headlamp Models.....	165	Disconnection and Removal.....	185
Removal.....	165	Installation and Connection.....	187
Bulb Replacement.....	166	Jump Starting.....	188
Installation.....	168	Positive Cable.....	189
Headlamp Bulb Replacement: Dual Headlamp Models....	168	Negative Cable.....	189
Removal.....	168	Fuses and Relays.....	190
Bulb Replacement.....	168	Main Fuse.....	190
Installation.....	169	System Fuses.....	190
Headlamp Alignment.....	170	SEAT.....	193
Headlamp Adjustment: Single Headlamp Models.....	172	Removal.....	193
Headlamp Adjustment: Dual Headlamp Models.....	173	Installation.....	194
Auxiliary Lamps.....	174	Motorcycle Storage.....	196
Turn Signal Bulb Replacement: Bullet Style.....	174	Placing Motorcycle in Storage.....	196
Turn Signal Bulb Replacement: Flat Lens Style.....	175	Removing Motorcycle From Storage.....	198
Tail Lamp Bulb Replacement.....	176	CARE AND CLEANING	
Removal.....	176	Cleaning and General Care.....	201
Installation.....	177	Washing the Motorcycle.....	205
Alternator/Voltage Regulator.....	177	Preparation.....	205
Charging Rate.....	177	Cleaning the Wheels and Tires.....	205
Battery: General.....	178	Washing the Motorcycle.....	205
Type.....	178	Drying the Motorcycle.....	205
Voltmeter Test.....	181	Polishing and Sealing.....	206
Cleaning and Inspection.....	181	Finishing Tires.....	206
Charging.....	182	Denim Finish Care.....	206
Storage.....	184		

TABLE OF CONTENTS

How to Clean.....	206
Leather Care.....	206
Wheel Care.....	207
Whitewall Tires.....	207
Windshield Care.....	208

TROUBLESHOOTING

Troubleshooting: General.....	209
Engine: Touring Models.....	209
Starter Does Not Operate or Does Not Turn Engine Over.....	209
Engine Turns Over But Does Not Start.....	209
Starts Hard.....	209
Starts But Runs Irregularly or Misses.....	210
A Spark Plug Fouls Repeatedly.....	210
Pre-ignition or Detonation (Knocks or Pings).....	210
Overheats.....	210
Excessive Vibration.....	210
Electrical System.....	211
Alternator Does Not Charge.....	211
Alternator Charge Rate is Below Normal.....	211
Transmission.....	211
Transmission Shifts Hard.....	211
Transmission Jumps Out of Gear.....	211
Clutch Slips.....	211

Clutch Drags or Does Not Release.....	211
Clutch Chatters.....	211
Brakes.....	211
ABS System Behavior.....	211
Brakes Do Not Hold Normally.....	211
HEATED HAND GRIPS.....	212

WARRANTIES AND RESPONSIBILITIES

Warranty and Maintenance.....	213
Keeping It All Harley-Davidson.....	213
California Evaporative Emission Controls: 2010 Models.....	214
EPA Noise Regulations in the United States.....	214
EPA Regulations.....	214
Warranty/Service Information.....	215
Reporting Safety Defects in United States.....	215
NHTSA Statement.....	215
Required Documentation for Imported Motorcycles.....	216
Owner Contact Information.....	216

LIMITED MOTORCYCLE WARRANTY

2010 HARLEY-DAVIDSON MOTORCYCLE LIMITED WARRANTY.....	217
24 Months/Unlimited Miles.....	217
Duration.....	217
Owner's Obligations.....	217

TABLE OF CONTENTS

Exclusions.....	218	Other Rights.....	224
Other Limitations.....	218	Recommendations for Required Maintenance.....	224
Important: Read Carefully.....	219		
LIMITED NOISE WARRANTY		LIMITED RADIO WARRANTY	
2010 HARLEY-DAVIDSON MOTORCYCLE NOISE CONTROL SYSTEM LIMITED WARRANTY.....	221	2010 LIMITED RADIO WARRANTY.....	225
Other Rights.....	222	Other Rights.....	225
Recommendations for Required Maintenance.....	222	MAINTENANCE SCHEDULING	
LIMITED EMISSION WARRANTY		Regular Service Intervals.....	227
2010 HARLEY-DAVIDSON EMISSION CONTROL SYSTEM LIMITED WARRANTY.....	223	Service Literature.....	231
		H-D Michigan, Inc. Trademark Information.....	231
		Product Registered Marks.....	232

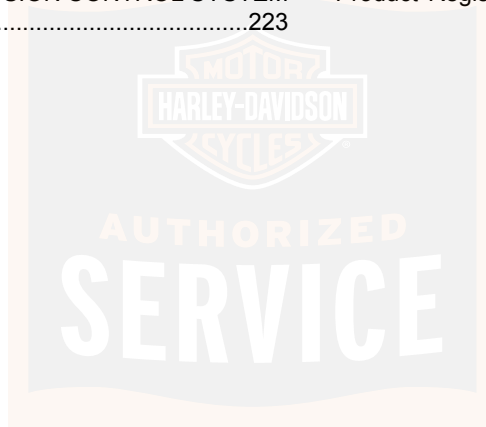

NOTES



SAFETY DEFINITIONS

Statements in this manual preceded by the following words are of special significance:

▲ WARNING

WARNING indicates a potentially hazardous situation which, if not avoided, could result in death or serious injury. (00119a)

▲ CAUTION

CAUTION indicates a potentially hazardous situation which, if not avoided, may result in minor or moderate injury. (00139a)

NOTICE

NOTICE indicates a potentially hazardous situation which, if not avoided, may result in property damage. (00140b)

NOTE

A NOTE refers to important information and is placed in italic type. It is recommended that you take special notice of these items.

HARLEY-DAVIDSON MOTORCYCLES ARE FOR ON-ROAD USE ONLY

This motorcycle is not equipped with a spark arrester and is designed to be used only on the road. Operation of off-road usage in some areas may be illegal. Obey local laws and regulations. This manual should be considered a permanent part of the motorcycle and should remain with the motorcycle when resold.

VISIT THE HARLEY-DAVIDSON WEB SITE

<http://www.harley-davidson.com>

YOUR OWNER'S MANUAL

We Care About You

Welcome to the Harley-Davidson Motorcycling Family! When enjoying your Harley-Davidson motorcycle, be sure to ride safely, respectfully and within the limits of the law and your abilities. Always wear a helmet, proper eyewear and protective clothing, and insist your passenger does too. Never ride while under the influence of alcohol or drugs. Know your Harley and read and understand your owner's manual from cover to cover.

This manual has been prepared to acquaint you with the operation, care and maintenance of your motorcycle and to provide you with important safety information. Follow these instructions carefully for maximum motorcycle performance and for your personal motorcycling safety and pleasure. Your Owner's Manual contains instructions for operation and minor

maintenance. Major repairs are covered in the Harley-Davidson Service Manual. Such major repairs require the attention of a skilled technician and the use of special tools and equipment. Your Harley-Davidson dealer has the facilities, experience and Genuine Harley-Davidson parts necessary to properly render this valuable service. We recommend that any emission system maintenance be performed by an authorized Harley-Davidson dealer.

Attend a rider safety course. To enroll in a Harley-Davidson Riding Academy course, call 1-414-343-4056 (U.S.) or visit www.harley-davidson.com/learntoride. In the United States, for information about Motorcycle Safety Foundation rider courses, call 1-800-446-9227 or visit www.msf-usa.org.

United States Owners

Your Harley-Davidson motorcycle conforms to all applicable U.S. Federal Motor Vehicle Safety Standards and U.S. Environmental Protection Agency regulations effective on the date of manufacture. Protect your privilege to ride by joining the American Motorcyclist Association. Visit www.americanmotorcyclist.com for more information.

Harley-Davidson reserves the right to change specifications, equipment or designs at any time without notice and without incurring obligation.

CUSTOMER SERVICE ASSISTANCE

Most sales or service issues are resolved at the dealership.

1. Discuss your problem with the appropriate personnel at the dealership in the Sales, Service or Parts area. If that proves unsuccessful, speak to the owner of the dealership or the general manager.
2. If you cannot resolve the issue with the dealership, contact the Harley-Davidson Customer Support Center. Harley-Davidson Motor Company Attention: Harley-Davidson Customer Support Center P.O. Box 653 Milwaukee, Wisconsin 53201 1-800-258-2464 (U.S. only) 1-414-343-4056

For customers outside the US, contact your local Harley-Davidson market office, call 1-414-343-4056 or visit harley-davidson.com.

Table 2. Vehicle and Personal Data

PERSONAL INFORMATION	DEALER INFORMATION
Date of Purchase:	
Name:	Name:
Address:	Address:
Address:	Address:
Vehicle Identification Number:	Sales Contact:
Key Number:	Service Contact:



NOTES



SAFE OPERATING RULES

▲ WARNING

Motorcycles are different from other vehicles. They operate, steer, handle and brake differently. Unskilled or improper use could result in loss of control, death or serious injury.

- Take a rider training course.
- Read owner's manual before riding, adding accessories or servicing.
- Wear a helmet, eye protection and protective clothing.
- Never tow a trailer.

(00556d)

- Take a rider training course.
- Read Owner's Manual before riding, adding accessories or servicing.
- Wear a helmet, eye protection and protective clothing.
- Never tow a trailer.

Before operating your new motorcycle it is your responsibility to read and follow the operating and maintenance instructions in this manual, and follow these basic rules for your personal safety.

- Know and respect the rules of the road (see SAFETY FIRST > RULES OF THE ROAD (Page 11)). Carefully read and observe the rules contained in the RIDING TIPS booklet accompanying this Owner's Manual. Read and familiarize yourself with the contents of the MOTORCYCLE HANDBOOK for your state.
- Before starting engine, check for proper operation of brake, clutch, shifter, throttle controls, correct fuel and oil supply.

▲ WARNING

Harley-Davidson parts and accessories are designed for Harley-Davidson motorcycles. Using non-Harley-Davidson parts or accessories can adversely affect performance, stability or handling, which could result in death or serious injury. (00001b)

▲ WARNING

Stop the engine when refueling or servicing the fuel system. Do not smoke or allow open flame or sparks near gasoline. Gasoline is extremely flammable and highly explosive, which could result in death or serious injury. (00002a)

- Use only Harley-Davidson approved parts and accessories. Use of certain other manufacturer's performance parts will void your new motorcycle warranty. See your Harley-Davidson dealer for details.

When refueling your motorcycle, the following rules should be observed.

- Refuel in a well ventilated area with the engine turned off.
- Remove fuel filler cap slowly.
- Do not smoke or allow open flames or sparks when refueling or servicing the fuel system.
- Do not fill fuel tank above the bottom of the filler neck insert.
- Leave air space to allow for fuel expansion.

⚠ WARNING

Do not store motorcycle with gasoline in tank within the home or garage where open flames, pilot lights, sparks or electric motors are present. Gasoline is extremely flammable and highly explosive, which could result in death or serious injury. (00003a)

⚠ WARNING

Engine exhaust from this product contains chemicals known to the State of California to cause cancer, and birth defects or other reproductive harm. (00004f)

⚠ WARNING

Do not run motorcycle in a closed garage or confined area. Inhaling motorcycle exhaust, which contains poisonous carbon monoxide gas, could result in death or serious injury. (00005a)

⚠ WARNING

The jiffy stand locks when placed in the full forward (down) position with vehicle weight on it. If the jiffy stand is not in the full forward (down) position with vehicle weight on it, the vehicle can fall over which could result in death or serious injury. (00006a)

⚠ WARNING

Be sure jiffy stand is fully retracted before riding. If jiffy stand is not fully retracted, it can contact the road surface causing a loss of vehicle control, which could result in death or serious injury. (00007a)

- A new motorcycle must be operated according to the special break-in procedure. See OPERATION > BREAK-IN RIDING RULES (Page 132).
- Operate motorcycle only at moderate speed and out of traffic until you have become thoroughly familiar with its operation and handling characteristics under all conditions.

NOTE

We recommend that you obtain information and formal training in the correct motorcycle riding technique. In the United States, the Motorcycle Safety Foundation® offers beginning and advanced rider safety courses. Call 800-446-9227 for information.

⚠ WARNING

Travel at speeds appropriate for road and conditions and never travel faster than posted speed limit. Excessive speed can cause loss of vehicle control, which could result in death or serious injury. (00008a)

- Do not exceed the legal speed limit or drive too fast for existing conditions. Always reduce speed when poor driving conditions exist. High speed increases the influence of any other condition affecting stability and increases the possibility of loss of control.
- Pay strict attention to road surfaces and wind conditions. Any two wheeled vehicle may be subject to upsetting forces such as wind blasts from passing trucks, holes in the pavement, rough road surfaces, rider control error, etc. These forces may influence the handling characteristics of your motorcycle. If this happens, reduce speed and guide the motorcycle with a relaxed grip to a controlled condition. Do not brake abruptly or force the handlebar. This may aggravate an unstable condition.

- Keep cargo weight concentrated close to the motorcycle and as low as possible to minimize the change in the motorcycle's center of gravity. Distribute weight evenly on both sides of the vehicle and do not load bulky items too far behind the rider or add weight to the handlebars or front forks. Do not exceed maximum specified load in each saddlebag.

NOTE

New riders should gain experience under various conditions while driving at moderate speeds.

- Operate your motorcycle defensively. Remember, a motorcycle does not afford the same protection as an automobile in an accident. One of the most common accident situations occurs when the driver of the other vehicle fails to see or recognize a motorcycle and turns left into the on-coming motorcyclist. Operate only with headlamp on.

⚠ WARNING

Avoid contact with exhaust system and wear protective clothing that completely covers legs while riding. Exhaust pipes and mufflers get very hot when engine is running and remain too hot to touch, even after engine is turned off. Failure to wear protective clothing could result in burns or other serious injury. (00009a)

- Wear an approved helmet, clothing, and foot gear suited for motorcycle riding. Bright or light colors are best for greater visibility in traffic, especially at night. Avoid loose, flowing garments and scarves.
- When carrying passengers, it is your responsibility to instruct them on proper riding procedures. (See the RIDING TIPS booklet included in your Harley-Davidson Owner's Kit.)
- Do not allow other individuals, under any circumstances, to operate your motorcycle unless you know they are experienced, licensed riders and are thoroughly familiar with the operation of your particular motorcycle.
- Protect your motorcycle against theft. After parking your motorcycle, lock the steering head and remove ignition key from switch. Set security alarm if present.
- Safe motorcycle operation requires alert mental judgment combined with a defensive driving attitude. Do not allow fatigue, alcohol or drugs to endanger your safety or that of others.
- Vehicles equipped with a sound system should have the volume adjusted to a non-distracting level before operating vehicle.

- Maintain your motorcycle in proper operating condition in accordance with Table 44. Particularly important to motorcycle stability is proper tire inflation pressure, tread condition, and proper adjustment of wheel bearings and steering head bearings.

▲ WARNING

Do not operate vehicle with forks locked. Locking the forks restricts the vehicle's turning ability, which could result in death or serious injury. (00035a)

▲ WARNING

Perform the service and maintenance operations as indicated in the regular service interval table. Lack of regular maintenance at the recommended intervals can affect the safe operation of your motorcycle, which could result in death or serious injury. (00010a)

▲ WARNING

Do not operate motorcycle with loose, worn or damaged steering or suspension systems. Contact a Harley-Davidson dealer for repairs. Loose, worn or damaged steering or suspension components can adversely affect stability and handling, which could result in death or serious injury. (00011a)

⚠ WARNING

Regularly inspect shock absorbers and front forks. Replace leaking, damaged or worn parts that can adversely affect stability and handling, which could result in death or serious injury. (00012a)

⚠ WARNING

Use Harley-Davidson replacement fasteners. Aftermarket fasteners can adversely affect performance, which could result in death or serious injury. (00013a)

- See your Harley-Davidson service manual for proper torque values.
- Aftermarket fasteners may not have the specific property requirements to perform properly.

⚠ WARNING

Be sure tires are properly inflated, balanced, undamaged, and have adequate tread. Inspect your tires regularly and see a Harley-Davidson dealer for replacements. Riding with excessively worn, unbalanced, improperly inflated, overloaded or damaged tires can lead to tire failure and adversely affect stability and handling, which could result in death or serious injury. (00014b)

⚠ WARNING

Replace punctured or damaged tires. In some cases, small punctures in the tread area may be repaired from within the removed tire by a Harley-Davidson dealer. Speed should NOT exceed 80 km/h (50 mph) for the first 24 hours after repair, and the repaired tire should NEVER be used over 129 km/h (80 mph). Failure to follow this warning could lead to tire failure and result in death or serious injury. (00015b)

⚠ WARNING

Do not exceed the motorcycle's Gross Vehicle Weight Rating (GVWR) or Gross Axle Weight Rating (GAWR). Exceeding these weight ratings can lead to component failure and adversely affect stability, handling and performance, which could result in death or serious injury. (00016f)

- GVWR is the sum of the weight of the motorcycle, accessories, and the maximum weight of the rider, passenger and cargo that can be safely carried.
- The GVWR is shown on the information plate, located on the frame steering head or the frame downtube.
- GAWR is the maximum amount of weight that can be safely carried on each axle.

▲ WARNING

Do not tow a disabled motorcycle. Towing can adversely affect stability and handling, which could result in death or serious injury. (00017a)

▲ WARNING

Do not pull a trailer with a motorcycle. Pulling a trailer can cause tire overload, damage and failure, reduced braking performance, and adversely affect stability and handling, which could result in death or serious injury. (00018c)

▲ WARNING

Contact with DOT 4 brake fluid can have serious health effects. Failure to wear proper skin and eye protection could result in death or serious injury.

- If inhaled: Keep calm, remove to fresh air, seek medical attention.
- If on skin: Remove contaminated clothing. Rinse skin immediately with plenty of water for 15-20 minutes. If irritation develops, seek medical attention.
- If in eyes: Wash affected eyes for at least 15 minutes under running water with eye lids held open. If irritation develops, seek medical attention.

- If swallowed: Rinse mouth and then drink plenty of water. Do not induce vomiting. Contact Poison Control. Immediate medical attention required.
- See Safety Data Sheet (SDS) for more details available at sds.harley-davidson.com

(00240e)

▲ WARNING

Batteries, battery posts, terminals and related accessories contain lead and lead compounds, and other chemicals known to the State of California to cause cancer, and birth defects or other reproductive harm. Wash hands after handling. (00019e)

▲ WARNING

Do not open storage compartments while riding. Distractions while riding can lead to loss of control, which could result in death or serious injury. (00082a)

▲ WARNING

Consult a Harley-Davidson dealer regarding any questions or problems that occur in the operation of your motorcycle. Failure to do so can aggravate an initial problem, cause costly repairs, cause an accident and could result in death or serious injury. (00020a)

- Be sure all equipment required by federal, state and local law is installed and in good operating condition.

ADDITIONAL SAFE OPERATING RULES

⚠ WARNING

If ABS lamp continues flashing at speeds greater than 5 km/h (3 mph) or remains on continuously, the ABS is not operating. The standard brake system is operational, but wheel lock up can occur. Contact a Harley-Davidson Dealer to have ABS repaired. A locked wheel will skid and can cause loss of vehicle control, which could result in death or serious injury. (00361b)

⚠ WARNING

ABS cannot prevent lockup of rear wheel due to engine braking. ABS will not aid in cornering or on loose/uneven surfaces. A locked wheel will skid and can cause loss of vehicle control, which could result in death or serious injury. (00362a)

RULES OF THE ROAD

- Always sound your horn, actuate your turn signals, and exercise caution when passing other vehicles going in the same direction. Never try to pass another vehicle going in the same direction at street intersections, on curves, or when going up or down a hill.

- At street intersections give the right-of-way. Do not presume you have the right-of-way, as the other driver may not know it is your turn.
- Always signal when preparing to stop, turn or pass.
- All traffic signs, including those used for the control of traffic at intersections, should be obeyed promptly. SLOW DOWN signs near schools and CAUTION signs at railroad crossings should always be observed and your actions governed accordingly.
- When intending to turn, signal at least 30.5 m (100 ft) before reaching the turning point. If turning across an intersection, move over to the centerline of the street (unless local rules require otherwise). Slow down when entering the intersection and turn carefully.
- Never anticipate a traffic light. When a change is indicated from GO to STOP (or vice versa) in the traffic control systems at intersections, slow down and wait for the light to change. Never run through a yellow or red traffic light.
- While turning either right or left, watch for pedestrians, animals, as well as vehicles.
- Do not leave the curb or parking area without signaling. Be sure your way is clear to enter moving traffic. A moving line of traffic always has the right-of-way.

- Be sure your license plate is installed in the position specified by law and is clearly visible at all times. Keep the plate clean.
- Ride at a safe speed that is consistent with the type of highway you are on. Pay strict attention to whether the road is dry, oily, icy or wet.
- Watch for debris such as leaves or loose gravel.
- Weather and traffic conditions on the highway dictate adjusting your speed and driving habits accordingly.

ACCESSORIES AND CARGO

Harley-Davidson Motor Company cannot test and make specific recommendations concerning every accessory or combination of accessories sold. Therefore, the rider must be responsible for safe operation of the motorcycle when installing accessories or carrying additional weight.

⚠ WARNING

See **ACCESSORIES AND CARGO** section within the **SAFETY FIRST** section in your owner's manual. Improper cargo loading or accessory installation can cause component failure and adversely affect stability, handling and performance, which could result in death or serious injury. (00021c)

⚠ WARNING

Do not exceed the motorcycle's Gross Vehicle Weight Rating (GVWR) or Gross Axle Weight Rating (GAWR). Exceeding these weight ratings can lead to component failure and adversely affect stability, handling and performance, which could result in death or serious injury. (00016f)

- GVWR is the sum of the weight of the motorcycle, accessories, and the maximum weight of the rider, passenger and cargo that can be safely carried.
- GAWR is the maximum amount of weight that can be safely carried on each axle.
- The GVWR and GAWR are shown on the information plate which is located on the frame down tube in some destinations.

⚠ WARNING

Do not pull a trailer with a motorcycle. Pulling a trailer can cause tire overload, damage and failure, reduced braking performance, and adversely affect stability and handling, which could result in death or serious injury. (00018c)

Accessory and Cargo Guidelines

The following guidelines should be used when equipping a motorcycle, carrying passengers and/or cargo.

⚠ WARNING

Travel at speeds appropriate for road and conditions and never travel faster than posted speed limit. Excessive speed can cause loss of vehicle control, which could result in death or serious injury. (00008a)

- Do not exceed the legal speed limit or drive too fast for existing conditions. Always reduce speed when poor driving conditions exist. High speed increases the influence of any other condition affecting stability and increases the possibility of loss of control.
- Pay strict attention to road surfaces and wind conditions. Any two wheeled vehicle may be subject to upsetting forces such as wind blasts from passing trucks, holes in the pavement, rough road surfaces, rider control error, etc. These forces may influence the handling characteristics of your motorcycle. If this happens, reduce speed and guide the motorcycle with a relaxed grip to a controlled condition. Do not brake abruptly or force the handlebar. This may aggravate an unstable condition.

- Keep cargo weight concentrated close to the motorcycle and as low as possible. This minimizes the change in the motorcycle's center of gravity.
- Distribute weight evenly on both sides of the vehicle.
- Do not load bulky items too far behind the rider or add weight to the handlebars or front forks.
- Do not exceed maximum specified load in each saddlebag.
- Luggage racks are designed for lightweight items. Do not overload racks.
- Be sure cargo is secure and will not shift while riding and recheck the cargo periodically. Accessories that change the operator's riding position may increase reaction time and affect handling of the motorcycle.
- Additional electrical equipment may overload the motorcycle's electrical system possibly resulting in electrical system and/or component failure.

⚠ WARNING

If Equipped: Front and/or rear guards are not intended to provide protection from bodily injury in a collision with another vehicle or any other object. (00022d)

Large surfaces such as fairings, windshields, back rests, and luggage racks can adversely affect handling. Only genuine

Harley-Davidson items designed specifically for the motorcycle model should be used with proper installation.

⚠ WARNING

Harley-Davidson parts and accessories are designed for Harley-Davidson motorcycles. Using non-Harley-Davidson parts or accessories can adversely affect performance, stability or handling, which could result in death or serious injury. (00001b)

⚠ WARNING

Only Touring Harley-Davidson Motorcycles are suitable for sidecar use. Consult a Harley-Davidson dealer. Use of motorcycles other than Touring models with sidecars could result in death or serious injury. (00040a)

NOISE CONTROL SYSTEM

Tampering

Owners are warned that removal or replacement of any noise control system component may be prohibited by law. This prohibition applies prior to vehicle sale or delivery to the ultimate purchaser. Use of a vehicle on which noise control system components have been removed or rendered inoperative may also be prohibited by law.

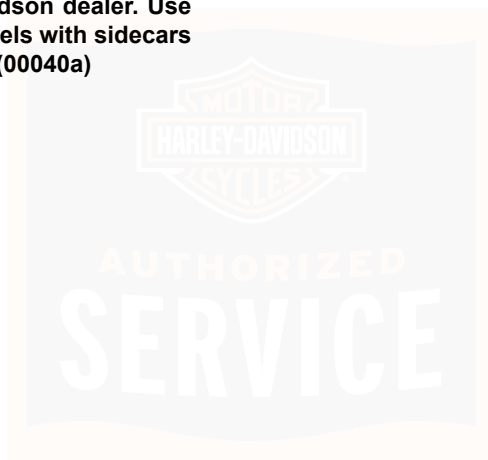

VEHICLE IDENTIFICATION NUMBER (V.I.N.)

General

See Figure 2. A unique 17-digit serial or Vehicle Identification Number (V.I.N.) is assigned to each motorcycle. For a description of each item in the V.I.N., refer to Table 3.

Location

See Figure 1. The full 17-digit V.I.N. is stamped on the right side of the frame near the steering head. In some destinations, a printed V.I.N. label is also attached to the right front downtube.

Abbreviated V.I.N.

An abbreviated V.I.N. showing the vehicle model, engine type, model year, and sequential number is stamped on the left side of the crankcase between the engine cylinders.

NOTE

Always give the full 17-digit Vehicle Identification Number when ordering parts or making any inquiry about your motorcycle.

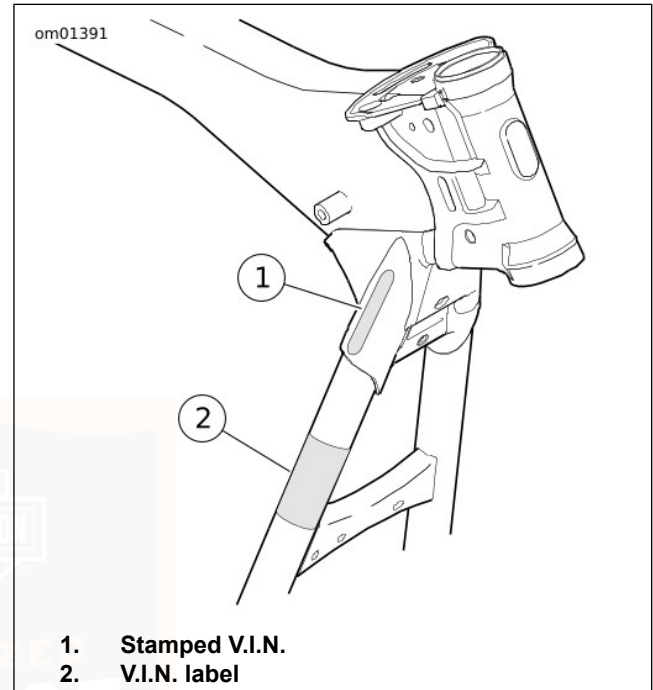

Figure 1. V.I.N. Locations

om00883c

① ② ③ ④ ⑤ ⑥ ⑦ ⑧ ⑨ ⑩

1 HD 1 KE M A 9 A B 600041

Figure 2. Typical Harley-Davidson V.I.N.: 2010 Touring Models

Table 3. Harley-Davidson V.I.N. Breakdown: 2010 Touring Models

POSITION	DESCRIPTION	POSSIBLE VALUES
1	Market designation	1=Originally manufactured for sale within the United States 5=Originally manufactured for sale outside of the United States
2	Manufacturer/vehicle type	HD=Harley-Davidson motorcycle
3	Motorcycle type	1=Heavyweight motorcycle (901 cc or larger)
4	Model	See V.I.N. model code table
5	Engine type	4=Twin Cam 96™, 1584 cc air-cooled, fuel-injected M=Twin Cam 103™, 1690 cc air-cooled, fuel-injected

SERVICE

Table 3. Harley-Davidson V.I.N. Breakdown: 2010 Touring Models

POSITION	DESCRIPTION	POSSIBLE VALUES	
6	Introduction date/calibration	Normal Introduction 1=Domestic 3=California A=Canada C=HDI E=Japan G=Australia J=Brazil	Mid-year or Special Introduction 2, 4=Domestic 5, 6=California B=Canada D=HDI F=Japan H=Australia K=Brazil
7	V.I.N. check digit	Can be 0-9 or X	
8	Model year	A=2010	
9	Assembly plant	B=York, PA U.S.A.	
10	Sequential number	Varies	

Table 4. V.I.N. Model Codes: 2010 Touring Models

CODE	MODEL	CODE	MODEL
FB	FLHR Road King®	FV	FLHT Electra Glide® Standard
FR	FLHRC Road King® Classic	FF	FLHTC Electra Glide® Classic
FW	FLHR Road King® Shrine	FC	FLHTCU Ultra Classic® Electra Glide®
KH	FLTRX Road Glide® Custom	FL	FLHTCU Ultra Classic® Electra Glide® Shrine
KB	FLHX Street Glide™	FG	FLHTCU Ultra Classic® Electra Glide® with sidecar
KE	FLHTK Electra Glide® Ultra Limited		

LABELS

See Figure 3 for safety and maintenance labels which were on the vehicle when new. If removed, replacement labels may be purchased for your motorcycle. Refer to Table 5 for label descriptions.

NOTE

Some labels may be available in different languages for destinations outside the U.S. See a Harley-Davidson dealer for all labels available for purchase.

Table 5. Labels

ITEM	PART NO.	DESCRIPTION	LOCATION
1	29127-95B	General warnings	Top of air cleaner cover
2	15368-01A	Battery warning	Under seat, behind fuel tank on main harness trough
3	14148-86	Engine guard warning	On front of engine guard below center mount and on each bag guard
4	90820-93D	Saddlebag load limits	Inside saddlebag
5	90821-74C	Tour-Pak load limits	Inside Tour-Pak lid

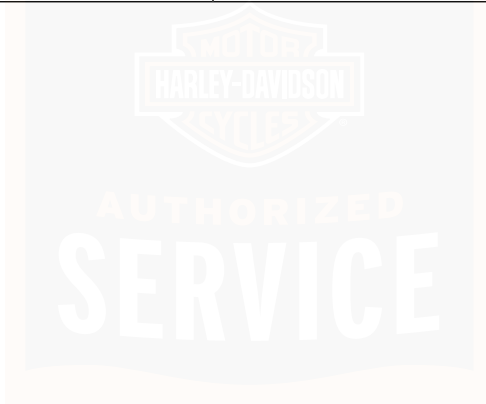

1

⚠ WARNING

Motorcycles are different from other vehicles. They operate, steer, handle and brake differently. Unskilled or improper use could result in loss of control, death or serious injury.

- Take a rider training course.
- Read Owner's Manual before riding, adding accessories or servicing.
- Wear a helmet, eye protection and protective clothing.
- Never tow a trailer.

For a manual, find nearest dealer at 1-800-443-2153 or www.harley-davidson.com 29127-90B

4

⚠ WARNING

Too much weight in saddlebags can cause loss of control. Death or serious injury could occur.

- Do not put more than 15 pounds (6.8 kg) in each saddlebag on 2008 & earlier vehicles.
- Do not put more than 20 pounds (9.1 kg) in each saddlebag on 2009 & later vehicles.
- Put equal weight in each saddlebag.
- See Accessories and Cargo section of Owner's Manual

9089-002

2

⚠ WARNING

A connected battery can cause a spark or motorcycle startup while servicing. Death or serious injury could occur.

- Disconnect negative cable before servicing.
- Keep cable away from terminal while servicing.

15368-01A

3

THIS GUARD MAY PROVIDE LIMITED LEG AND COSMETIC VEHICLE PROTECTION UNDER UNIQUE CIRCUMSTANCES (FALL OVER WHILE STOPPED, VERY LOW SPEED SLIDE). IT IS NOT MADE NOR INTENDED TO PROVIDE PROTECTION FROM BODILY INJURY IN A COLLISION WITH ANOTHER VEHICLE OR ANY OTHER OBJECT.

5

⚠ WARNING

Too much weight in Tour-Pak® can cause loss of control. Death or serious injury could occur.

- Do not put more than 25 pounds (11.3 kg) in Tour-Pak® on 2008 & earlier motorcycles.
- Do not put more than 30 pounds (13.6 kg) in Tour-Pak® on 2009 & later motorcycles.
- See Accessories and Cargo section of Owner's Manual for more information.

90921-74C

Figure 3. Labels

SERVICE

NOTES



SPECIFICATIONS

Table 6. Engine: Twin Cam 96™

ITEM	SPECIFICATION	
Number of cylinders	2	
Type	4-cycle, 45 degree V-Type, air cooled	
Compression ratio	9.2:1	
Bore	3.750 in.	95.25 mm
Stroke	4.380 in.	111.25 mm
Displacement	96.00 cu. in.	1584.00 cu. cm
Lubrication system	Pressurized, dry sump	
Torque (North America)	92.60 ft-lbs @ 3500 RPM	125.57 Nm @ 3500 RPM
Torque (International)	90.20 ft-lbs @ 3400 RPM	122.31 Nm @ 3400 RPM
Torque (Japan)	86.90 ft-lbs @ 2500 RPM	117.84 Nm @ 2500 RPM

Table 7. Engine: Twin Cam 103™

ITEM	SPECIFICATION	
Number of cylinders	2	
Type	4-cycle, 45 degree V-Type, air-cooled	
Compression ratio	9.6:1	
Bore	3.875 in.	98.42 mm
Stroke	4.375 in.	111.12 mm

Table 7. Engine: Twin Cam 103™

ITEM	SPECIFICATION	
Displacement	103.00 cu. in.	1687.87 cu. cm
Lubrication system	Pressurized, dry sump with oil cooler	
Torque	101.00 ft-lbs @ 3500 RPM	137.00 Nm @ 3500 RPM

NOTE

Specifications in this publication may not match those of official certification in some markets due to timing of publication printing, variance in testing methods, and/or vehicle differences. Customers seeking officially recognized regulatory specifications for their vehicle should refer to certification documents and/or contact their respective dealer or distributor.

Table 8. Transmission

TRANSMISSION	SPECIFICATION
Type	Constant mesh, foot shift
Speeds	6 forward

Table 9. Electrical

COMPONENT	SPECIFICATION
Ignition timing	Not adjustable
Battery	12 volt, 28 amp-hr, 270 CCA sealed and maintenance free

Table 9. Electrical

COMPONENT	SPECIFICATION	
Charging system	Three-phase, 50-amp system (585W @ 13V, 2000 rpm, 650W max power @13V)	
Spark plug type	HD-6R12	
Spark plug size	12 mm	
Spark plug gap	0.038-0.043 in.	0.97-1.09 mm
Spark plug torque	12-18 ft-lbs	16.3-24.4 Nm

Table 10. Sprocket Teeth

DRIVE	ITEM	NUMBER OF TEETH
Primary	Engine	34
	Clutch	46
Final	Transmission	32
	Rear wheel	68

Table 11. Overall Drive Ratios

GEAR	RATIO
1st Gear	9.593
2nd Gear	6.650
3rd Gear	4.938
4th Gear	4.000
5th Gear	3.407
6th Gear	2.875

Table 12. Capacities

ITEM	U.S.	LITERS
Fuel tank (total)	6.00 gal	22.71
Low fuel warning light on	1.00 gal	3.79
Engine oil with filter	4.00 qt.	3.79
Transmission (approximate)	1.00 qt.	0.95
Primary chaincase (approximate)	1.40 qt.	1.32

Table 13. Tires

MODEL	MOUNT	SIZE	NUMBER	PRESSURE (COLD)	
				PSI	kPa
All models except FLHRC, FLTRX, FLHX	front	17 in.	Dunlop D408F 130/80 B17 65H	36	248
FLHRC	front	16 in.	Dunlop D408F 130/90 B16 67H	36	248
FLTRX, FLHX	front	18 in.	Dunlop D408F 130/70 B18 63H	36	248
All models	rear	16 in.	Dunlop D407 180/65 B16	40	276

NOTE
 Gross Vehicle Weight Rating (GVWR) (maximum allowable

loaded vehicle weight) and corresponding Gross Axle Weight Ratings (GAWR) are listed on a label located on the right side front downtube.

Table 14. Weights: FLHT, FLHTC, FLHTCU, FLHTK

ITEM	FLHT		FLHTC		FLHTCU		FLHTK	
	LB.	KG	LB.	KG	LB.	KG	LB.	KG
Weight as shipped from factory	774.00	351.08	827.00	375.12	852.00	386.46	857.00	388.73
GVWR	1360.00	616.89	1360.00	616.89	1360.00	616.89	1360.00	616.89
GAWR front	500.00	226.80	500.00	226.80	500.00	226.80	500.00	226.80
GAWR rear	927.00	420.48	927.00	420.48	927.00	420.48	927.00	420.48

Table 15. Weights: FLHR, FLHRC, FLTRX, FLHX

ITEM	FLHR		FLHRC		FLTRX		FLHX	
	LB.	KG	LB.	KG	LB.	KG	LB.	KG
Weight as shipped from factory	775.00	351.53	773.00	350.63	783.00	355.16	773.00	350.63
GVWR	1360.00	616.89	1360.00	616.89	1360.00	616.89	1360.00	616.89
GAWR front	500.00	226.80	500.00	226.80	500.00	226.80	500.00	226.80
GAWR rear	927.00	420.48	927.00	420.48	927.00	420.48	927.00	420.48



Table 16. Dimensions: FLHT, FLHTC, FLHTCU, FLHTK

ITEM	FLHT		FLHTC		FLHTCU		FLHTK	
	IN.	MM	IN.	MM	IN.	MM	IN.	MM
Wheel base	63.50	1612.90	63.50	1612.90	63.50	1612.90	63.50	1612.90
Overall length (Tour-Pak in rear-most position)	95.02	2413.51	98.30	2496.82	98.60	2504.44	98.60	2504.44
Overall width	38.00	965.20	38.00	965.20	38.00	965.20	38.00	965.20
Road clearance	5.10	129.54	5.10	129.54	5.10	129.54	5.10	129.54
Overall height	61.00	1549.49	61.00	1549.49	61.00	1549.49	61.00	1549.49
Saddle height*	27.30	693.42	27.30	693.42	27.30	693.42	27.30	693.42
*With 81.7 kg (180 lb) rider on seat								

Table 17. Dimensions: FLHR, FLHRC, FLTRX, FLHX

ITEM	FLHR		FLHRC		FLTRX		FLHX	
	IN.	MM	IN.	MM	IN.	MM	IN.	MM
Wheel base	63.50	1612.90	63.50	1612.90	63.50	1612.90	63.50	1612.90
Overall length	95.00	2413.00	94.20	2392.68	94.10	2390.14	95.00	2413.00
Overall width	37.40	949.96	37.50	952.50	35.80	909.32	38.00	965.20
Road clearance	5.10	129.54	5.10	129.54	5.10	129.54	4.70	119.38
Overall height	55.10	1399.54	55.10	1399.54	55.00	1397.00	52.20	1325.88
Saddle height*	27.30	693.42	26.90	683.26	26.90	683.26	26.30	668.02
*With 81.7 kg (180 lb) rider on seat								



Table 18. Bulb Chart

LAMP	DESCRIPTION (ALL LAMPS 12 VOLT)	BULBS REQUIRED	CURRENT DRAW AMPERAGE	HARLEY-DAVIDSON PART NUMBER
Headlamp	FLHT/C/U, FLHR/C, FLHX, FLHTK	1	4.58/5.0	68329-03
	FLTRX	2	4.58/5.0	68329-03
	Position lamp, international	1	0.32	53436-97
Tail and stop lamp	Tail/stop lamp, FLHX, FLTRX	1	0.59/2.10	68167-04
Turn signal lamp	Front/running	2	2.25/0.59	68168-89A
	Front international	2	1.75	68572-64B
	Front, FLHX (HDI)	2	1.75	68163-84
	Rear, FLHR, FLHRC, FLHT, FL- HTC, FLHTCU, FLHTK (all)	2	2.25	68572-64B
	Rear, FLHX, FLTRX (domestic)	2	2.25/0.59	68168-89A
	Rear, FLHX, FLTRX (international)*	LED	N/A	N/A
	Rear, FLHX, FLTRX (Canadian)	2	1.75	68163-84

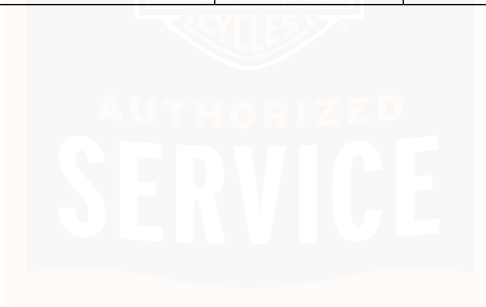

Table 18. Bulb Chart

LAMP	DESCRIPTION (ALL LAMPS 12 VOLT)	BULBS REQUIRED	CURRENT DRAW AMPERAGE	HARLEY-DAVIDSON PART NUMBER
Additional lighting	Tour-Pak side lamps* FLHTCU, FLHTK	N/A	0.14 0.14	53788-06 (right side) 53789-06 (left side)
	Tour-Pak tail/stop lamps	2	0.59/2.10	68165-64
	Fender tip lamps, front	1	0.30	68193-95
	Fender tip lamps, rear*	N/A	N/A	69375-06 (FLHX, FLTRX) 59672-09 (all but FLHX, FLTRX)
	License plate lamp international	1	0.37	53436-97
	License plate lamp FLHX, FLTRX domestic	2	0.35	52441-95
	Auxiliary lamps	2	2.1	68453-05
	Fog lamps international	2	2.7	68851-98
Instrument panel lamps FLHT/C/U FLHR/C FLTRX FLHX	High beam indicator	Instrument panel is illuminated with LEDs. Replace entire assembly upon failure.		
	Oil pressure indicator			
	Neutral indicator			
	Turn signal indicator			
Gauge lamps FLHR/C	Speedometer	N/A	N/A	N/A
	Odometer	N/A	N/A	N/A
	Fuel gauge*	Illuminated with LEDs. Replace assembly upon failure.		
	Engine	N/A	N/A	N/A

Table 18. Bulb Chart

LAMP	DESCRIPTION (ALL LAMPS 12 VOLT)	BULBS REQUIRED	CURRENT DRAW AMPERAGE	HARLEY-DAVIDSON PART NUMBER
Gauge lamps FLHT/C/U	Speedometer	N/A	N/A	N/A
	Tachometer	N/A	N/A	N/A
FLTRX	Voltmeter	1	0.24	67445-00
FLHX	Oil pressure gauge	1	0.24	67445-00
FLHTK	FLHT/C/U, FLHTK			
	Air temperature gauge FLHT/C/U, FLHTK	1	0.24	67445-00
	Fuel gauge	1	0.24	67445-00
Items with *	Illuminated with LEDs. Replace entire assembly upon failure.			

TIRE DATA

⚠ WARNING

Match tires, tubes, rim strips or seals, air valves and caps to the correct wheel. Contact a Harley-Davidson dealer. Mismatching can lead to tire damage, allow tire slippage on the wheel or cause tire failure, which could result in death or serious injury. (00023c)

⚠ WARNING

Harley-Davidson recommends the use of its specified tires. Harley-Davidson vehicles are not designed for operation with non-specified tires, including snow, moped and other special-use tires. Use of non-specified tires can adversely affect stability, handling or braking and lead to loss of vehicle control, which could result in death or serious injury. (00024d)

Tubeless tires fitted with the correct size inner tubes may be used on all Harley-Davidson laced (wire spoked) wheels. Protective rubber rim strips must be used with tubeless tires

(fitted with correct size inner tubes) when mounted on laced (wire spoked) wheels.

⚠ WARNING

Use inner tubes on laced (wire spoked) wheels. Using tubeless tires on laced wheels can cause air leaks, which could result in death or serious injury. (00025b)

Tubeless tires are used on all Harley-Davidson cast and disc wheels.

Tire sizes are molded on the tire sidewall. Inner tube sizes are printed on the tube.

⚠ WARNING

Harley-Davidson front and rear tires are not the same. Interchanging front and rear tires can cause tire failure, which could result in death or serious injury. (00026a)

⚠ WARNING

Do not inflate tire beyond maximum pressure as specified on sidewall. Over inflated tires can blow out, which could result in death or serious injury. (00027b)

⚠ WARNING

Replace tire immediately with a Harley-Davidson specified tire when wear bars become visible or only 1 mm (1/32 in) tread depth remains. Riding with a worn tire could result in death or serious injury. (00090c)

See SPECIFICATIONS > SPECIFICATIONS (Page 21) for tire pressures and sizes.

GASOLINE BLENDS

Your motorcycle was designed to get the best performance and efficiency using unleaded gasoline. Most gasoline is blended with alcohol and/or ether to create oxygenated blends. The type and amount of alcohol or ether added to the fuel is important.

NOTICE

Do not use gasoline that contains methanol. Doing so can result in fuel system component failure, engine damage and/or equipment malfunction. (00148a)

- Gasoline containing METHYL TERTIARY BUTYL ETHER (MTBE): Gasoline/MTBE blends are a mixture of gasoline and as much as 15% MTBE. Gasoline/MTBE blends can be used in your motorcycle.

- ETHANOL is a mixture of 10% ethanol (Grain alcohol) and 90% unleaded gasoline. Gasoline/ethanol blends can be used in your motorcycle if the ethanol content does **not** exceed 10%.
- REFORMULATED OR OXYGENATED GASOLINES (RFG): Reformulated gasoline is a term used to describe gasoline blends that are specifically designed to burn cleaner than other types of gasoline, leaving fewer tailpipe emissions. They are also formulated to evaporate less when you are filling your tank. Reformulated gasolines use additives to oxygenate the gas. Your motorcycle will run normally using this type of gas and Harley-Davidson recommends you use it when possible, as an aid to cleaner air in our environment.
- Do not use race gas or octane boosters. Use of these fuels will damage the fuel system.

Some gasoline blends might adversely affect the starting, driveability or fuel efficiency of the motorcycle. If any of these problems are experienced, try a different brand of gasoline or gasoline with a higher octane blend.

FUEL

Refer to Table 19. Always use a good quality unleaded gasoline. Octane ratings are usually found on the pump.

▲ WARNING

Avoid spills. Slowly open fuel filler cap. Do not fill above bottom of filler neck insert, leaving air space for fuel expansion. Secure filler cap after refueling. Gasoline is extremely flammable and highly explosive, which could result in death or serious injury. (00028b)

▲ WARNING

Use care when refueling. Pressurized air in fuel tank can force gasoline to escape through filler tube. Gasoline is extremely flammable and highly explosive, which could result in death or serious injury. (00029a)

Modern service station pumps dispense a high flow of gasoline into a motorcycle fuel tank making air entrapment and pressurization a possibility.

Table 19. Octane Ratings

SPECIFICATION	RATING
Pump Octane (R+M)/2	91 (95 RON)

CATALYTIC CONVERTER

The motorcycle is equipped with a catalytic converter in the exhaust pipe collector.

NOTICE

Do not operate catalytic converter-equipped vehicle with engine misfire. If you operate the vehicle under this condition, the exhaust will become abnormally hot, which can cause vehicle damage, including emission control loss. (00149c)

NOTICE

Use only unleaded fuel in catalytic converter-equipped motorcycles. Using leaded fuel will damage the emission control system. (00150c)



GENERAL: CONTROLS AND INDICATORS

⚠ WARNING

Identify and understand the specific features of your vehicle. Failure to understand how these features affect the vehicle's operation can lead to an accident, which could result in death or serious injury. (00043b)

Some features explained are unique to certain models. These features may be available as accessories for your Harley-Davidson motorcycle. See a Harley-Davidson dealer for a complete list of accessories that will fit your specific motorcycle.

IGNITION/HEADLAMP KEY SWITCH

⚠ WARNING

The automatic-on headlamp feature provides increased visibility of the rider to other motorists. Be sure headlamp is on at all times. Poor visibility of rider to other motorists can result in death or serious injury. (00030b)

See YOUR OWNER'S MANUAL section. Be sure to record all your key numbers in the space provided at the front of this book.

See Figure 4. The ignition/headlamp key switch controls electrical functions of the motorcycle.

⚠ WARNING

Do not operate vehicle with forks locked. Locking the forks restricts the vehicle's turning ability, which could result in death or serious injury. (00035a)

NOTICE

Protect your vehicle against theft. Failure to lock the motorcycle after parking could result in theft and/or equipment damage. (00151b)

NOTICE

Do not lubricate barrel locks with petroleum based lubricants or graphite. Inoperative locks may result. (00152a)

NOTE

- *Harley-Davidson recommends removing key from ignition/fork lock before operating motorcycle. If you do not remove key, it can fall out during operation.*
- *ACCESS/ACCESSORY - Accessories and hazard warning flasher can be turned on. Instrument lamps are on. Brake lamp and horn can be activated. Key may be removed.*
- *The lamps illuminate when the switch is in the IGNITION position, as required by law in some localities.*

Table 20. Ignition/Headlamp Switch Positions

MODEL	FUNCTION	LABEL	OPERATION
FLHR FLHRC	Switch		Switch is locked or unlocked by lifting switch cover, inserting key and turning key counterclockwise to lock, clockwise to unlock. Key may be removed in any position.
		OFF	Ignition, lamps and accessories are off.
		ACCESSORY	Accessories are on. Hazard warning flashers can be left on. Instrument lamps are on. Brake lamp and horn can be activated.*
		IGNITION	Ignition, lamps and accessories are on.*
Other models	Key Lock	LOCK	Locks the switch in either the FORK LOCK or ACCESS switch position. Remove the key for security.
		UNLOCK	Unlocks the switch. Unlocked, the switch can be rotated to any of the 4 positions. To prevent loss when riding, remove the key.
	Switch	FORK LOCK	Locks fork in left position to discourage unauthorized use of vehicle when parked. See CONTROLS AND INDICATORS > FORK LOCK (Page 34) for operation.
		OFF	When switch is in OFF position, the ignition, lamps and accessories are off.
		IGNITION	When the switch is in the IGNITION position, the motorcycle can be started and all lamps and accessories will operate.
		ACCESS	When the switch is in the ACCESS position, all the lamps and accessories will operate but the engine can not be started. In ACCESS, the switch can be locked.
* International models have an additional function. Position lamp and tail lamp are also on.			



om00705a

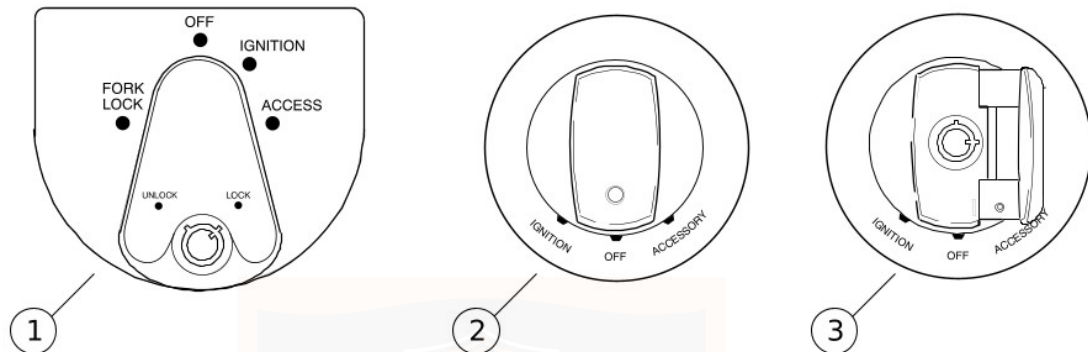

1. All except FLHR/FLHRC models
2. FLHR/FLHRC models (cover shown closed)

3. FLHR/FLHRC models (cover shown open)

Figure 4. Ignition/Headlamp Key Switch

FORK LOCK

NOTICE

Protect your vehicle against theft. Failure to lock the motorcycle after parking could result in theft and/or equipment damage. (00151b)

Using the fork lock immediately after parking your motorcycle will discourage unauthorized use or theft when parking your motorcycle.

See Figure 5. On FLHR/FLHRC models, the fork lock is located at the top of the steering head, behind the headlamp nacelle and inset in the handlebar clamp shroud.

See Figure 4. On other models, the fork lock is integrated into the ignition switch.

NOTE

Do not force the switch into the locked position or switch damage can occur.

⚠ WARNING

Do not operate vehicle with forks locked. Locking the forks restricts the vehicle's turning ability, which could result in death or serious injury. (00035a)

To Lock Fork on FLHR/FLHRC Models

1. Turn fork to full left position.
2. See Figure 5. Insert key and turn key counterclockwise to LOCK position. Remove key.
3. To unlock fork, insert key and turn clockwise to UNLOCK position. Remove key.

To Lock Fork on Other Models

1. Turn fork to full left position.
2. See Figure 4. Turn switch knob to FORK LOCK and push knob down.
3. Insert key and turn key to LOCK position. Remove key.
4. To unlock fork, insert key and turn to UNLOCK position. Remove key and rotate switch knob out from the FORK LOCK position.

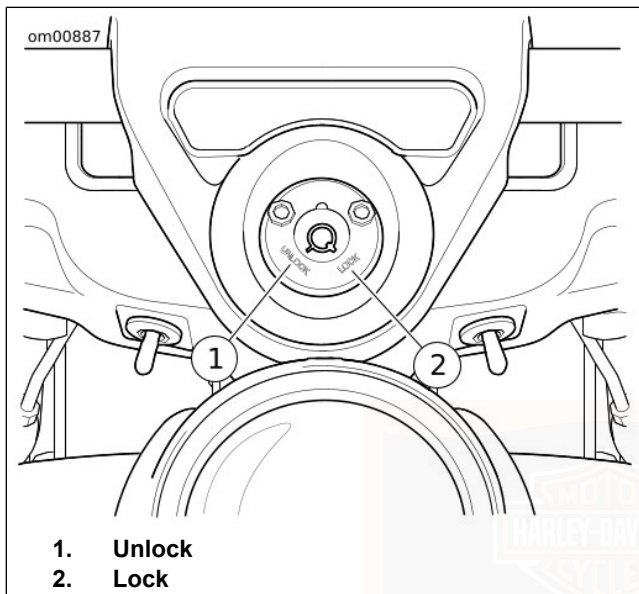

Figure 5. Fork Lock: FLHR/FLHRC
HAND CONTROLS: BASIC OPERATION

Electric Starter Switch

NOTE

Off/Run switch MUST be in RUN position to operate engine.

See Figure 6. The electric starter switch is located on the right handlebar control group. See OPERATION > STARTING THE ENGINE (Page 134) for detailed operation procedures.

1. Put the engine off/run switch in the RUN position and the transmission in neutral. Neutral (green) indicator lamp should be illuminated.
2. See Figure 4. Turn ignition/headlamp key switch to IGNITION and push the START switch to operate starter motor.

Engine OFF/RUN Switch

See Figure 6. The engine off/run switch (6) turns the ignition power ON or OFF. The engine off/run switch is located on the right handlebar control. Push the top portion of the engine off/run switch to turn off ignition power and shut the engine off. Push the bottom portion of the engine off/run switch to turn on ignition power.

NOTE

- *The engine off/run switch must be in the RUN position to start or operate the engine.*
 - *The engine off/run switch should be used to shut the engine off.*
1. To shut the engine off, push the top of the off/run switch to the ignition OFF position.

2. See Figure 4. Turn the ignition key to the OFF position to turn the ignition power completely OFF.

Throttle Control Grip

See Figure 6. The throttle control grip (8) is located on the right handlebar control and is operated with the right hand.

To reduce rider fatigue on long trips, a spring loaded throttle friction adjustment screw (9) is located at the bottom of the throttle grip clamp on non-cruise equipped models.

1. Slowly turn throttle control grip clockwise (toward the front of the motorcycle) to close the throttle (decelerate).
2. Slowly turn throttle control grip counterclockwise (toward rear of motorcycle) to open the throttle (accelerate).

⚠ WARNING

Do not tighten throttle friction adjustment screw to the point where the engine will not return to idle automatically. Over-tightening can lead to loss of vehicle control, which could result in death or serious injury. (00031b)

3. Unscrew the throttle friction adjustment screw so the throttle returns to the idle position when the hand is removed from the grip.

4. Screw the throttle adjustment screw in to increase friction on grip. This provides a damping effect on throttle motion.

NOTE

The throttle friction adjustment screw should not be used under normal stop and go operating conditions.

Clutch Hand Lever

⚠ WARNING

Do not position fingers between hand control lever and handlebar grip. Improper hand positioning can impair control lever operation and cause loss of vehicle control, which could result in death or serious injury. (00032a)

See Figure 6. The clutch hand lever (1) is located on the left handlebar and is operated with the fingers of the left hand.

1. Slowly pull clutch hand lever in against handlebar grip to fully disengage clutch.
2. Shift to first gear using the gear shifter lever. See CONTROLS AND INDICATORS > CRUISE CONTROL (Page 50).
3. Slowly release the clutch hand lever to engage clutch.

A clutch switch is incorporated into the left handlebar switch assembly. It enables the rider to start the vehicle in any gear

as long as the clutch lever is pulled in. If the clutch is not disengaged, the vehicle will not start when in gear.

Horn Switch

See Figure 6. The horn is operated by pushing on the horn switch (2) located on the left handlebar control group.

Headlamp Dimmer Switch

See Figure 6. The headlamp dimmer switch (3) is located on the left handlebar. The switch has two positions to activate the headlamps high or low beams.

- Press the top of the headlamp dimmer beam switch to activate the high beam.
- Press the bottom of the headlamp dimmer switch to return to the low beam.

See Figure 8. The (blue) high beam indicator lamp will illuminate when the high beam is on.

Turn Signal Switches

See Figure 6. Each handlebar control group contains a turn signal switch.

- The right turn signal switch (10) operates the right front and right rear flashing lamps.
- The left turn signal switch (4) operates the left front and left rear flashing lamps.

NOTE

Front turn signal lamps also function as running lamps (except International models).

Audio/CB Control Switches

On equipped models, the audio/CB control switches (11) set up and operate functions within the Advanced Audio System.

For vehicles with an audio system, see **ADVANCED AUDIO SYSTEM > ADVANCED AUDIO SYSTEM** (Page 77) for detailed operation.

Cruise Control Switches

On equipped models, the cruise control switches (12) automatically regulate the speed of the vehicle.

For vehicles with cruise control, see **CONTROLS AND INDICATORS > CRUISE CONTROL** (Page 50) for detailed operation.

om00276

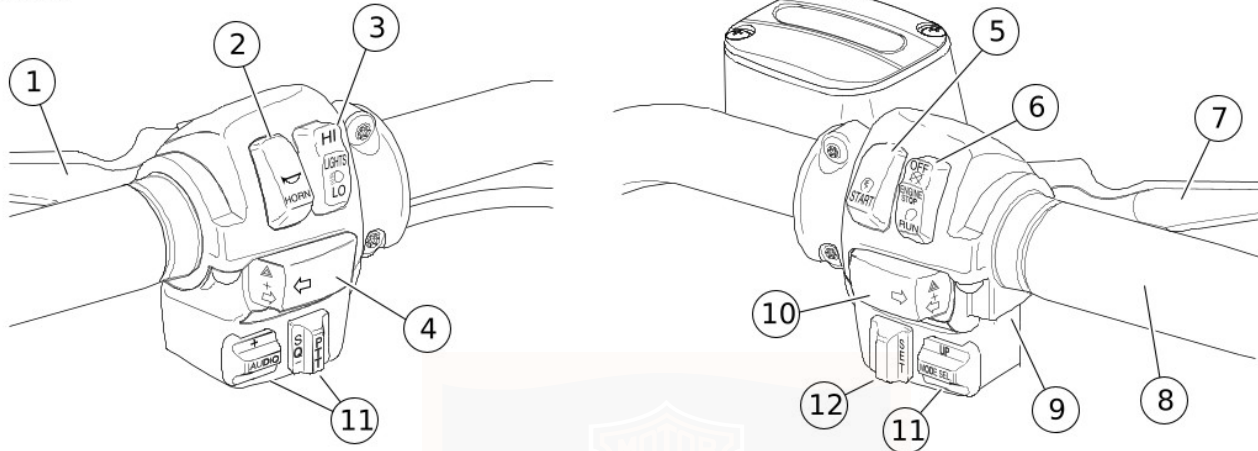

- 1. Clutch hand lever
- 2. Horn switch
- 3. Headlamp dimmer switch
- 4. Left turn signal switch
- 5. Electric starter switch
- 6. Engine off/run switch

- 7. Brake hand lever
- 8. Throttle control grip
- 9. Throttle friction adjusting screw (not shown, not used on cruise control models)
- 10. Right turn signal switch
- 11. Audio/CB switches (if equipped)
- 12. Cruise control switches (if equipped)

Figure 6. Basic Handlebar Controls (typical)

HEATED HAND GRIPS

See Figure 7. Models with heated hand grips have a variable heat control dial located on the end of the left hand grip.

Rotate the control dial to align the desired setting with the arrow on the grip. The heat settings range from 1 (minimum) to 6 (peak). Rotate to the OFF icon to turn off heat.

To prevent battery drain, the heated hand grips will only function while the engine is running. The hand grips produce peak heat with the engine running at cruising speed.

The hand grips are thermostatically-controlled, providing a constant grip temperature regardless of changes in the outside temperature.

If the hand grips are not producing heat, see TROUBLESHOOTING > HEATED HAND GRIPS (Page 212).

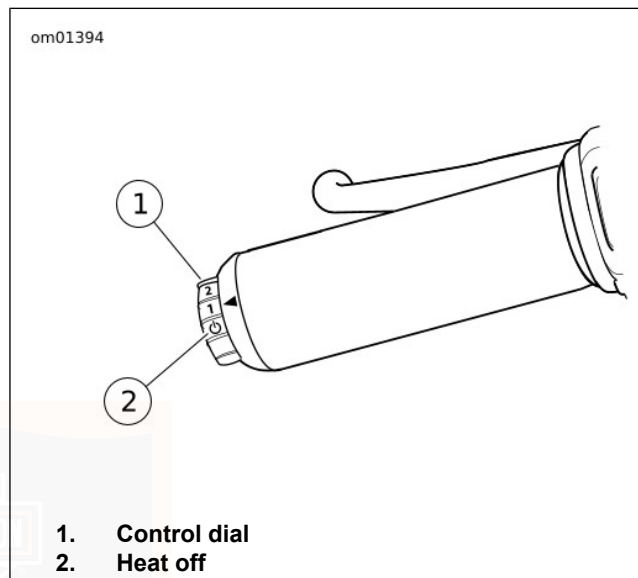

Figure 7. Heated Hand Grips

ELECTRONIC THROTTLE CONTROL (ETC)

Touring models are equipped with Electronic Throttle Control (ETC). Instead of using a mechanical cable connection to the throttle body, this technology uses redundant grip sensors to indicate rider requested throttle position to the Electronic Module (ECM). The ECM then regulates proper fuel/air intake and ignition timing based on the rider request. The grip sensor

is manufactured with internal cams and spring retainer for natural feel and operation.

ETC operation is designed for rider safety and continued motorcycle operation, even in the event of a component failure. The Electronic Control Module monitors the status of the grip sensors, throttle plate actuation and airflow. If any problems are detected, the motorcycle will disable cruise control, illuminate the engine check lamp, and revert to one of the following fallback modes.

ETC Limited Performance Mode

The rider will experience near-normal operation. The motorcycle will operate with provisions to guard against unintended acceleration.

ETC Power Management Mode

The throttle plate actuator returns to an "idle detent" or "limp-home" position, which will provide enough torque to achieve speed of about 40 km/h (25 mph). The motorcycle's response to grip sensor input is significantly reduced.

ETC Forced Idle Mode

The throttle plate actuator is forced to a "fast idle" position, which will provide enough torque to crawl, but not enough torque to operate at traffic speeds.

ETC Forced Shutdown Mode

The engine is forced to shut down.

TURN SIGNAL SWITCH OPERATION

The turn signal switches are used by the turn signal module to control turn signal operation based on vehicle speed, vehicle acceleration and turn completion.

Momentarily depress the desired turn signal switch. The turn signal lamps will begin and continue flashing until they are manually or automatically cancelled. As long as the motorcycle is stationary, the signals will flash.

NOTE

- *If you are signaling to turn in one direction and you depress the switch for the opposite turn signal, the first signal is cancelled and the opposite side begins flashing.*
- *If you want to stop the lamps from flashing, briefly depress the turn signal switch a second time. The turn signal lamps will stop flashing.*

HAZARD WARNING 4-WAY FLASHER

Use the following method to activate the four-way flashers.

1. With the ignition key ON and security system disarmed (if equipped), press the left and right turn signal switches at the same time.

2. Turn the ignition key OFF and arm the security system if present and desired. The four-way flashers will continue for two hours.
3. To cancel four-way flashing, disarm the security system if necessary, turn the ignition key ON and press the left and right turn signal switches at the same time.

This system allows a stranded vehicle to be left in the four-way flashing mode and secured until help is found.

INDICATOR LAMPS

See Figure 8. Five indicator lamps are provided.

- The green TURN indicators will flash when turn signals are activated; therefore, flashing indicates the chosen turn direction. When the 4-way hazard flashers are operating, both turn indicators will flash simultaneously.
- The blue BEAM indicator lamp, when lit, signals high beam headlamp operation.
- The green NEUTRAL lamp, when lit, signals the transmission is in neutral gear.
- The red OIL indicator lamp, when lit, signals that oil is not circulating through the engine.

NOTE

The OIL indicator lamp will glow when the ignition is turned on prior to starting engine. With engine running, lamp should be off when engine speed is above idle.

Several other circumstances that could cause the red oil indicator lamp to signal, include the following:

- If the oil pressure indicator lamp does not go off at speeds above idling, it is usually because of an empty oil tank or diluted oil.
- In freezing weather the oil feed may clog with ice and sludge, preventing oil circulation.
- A grounded oil signal switch wire.
- A faulty signal switch.
- A damaged or improperly installed check valve.
- Trouble with the pump.

NOTICE

If the oil pressure indicator lamp remains lit, always check the oil supply first. If the oil supply is normal and the lamp is still lit, stop the engine at once and do not ride further until the trouble is located and the necessary repairs are made. Failure to do so may result in engine damage. (00157a)

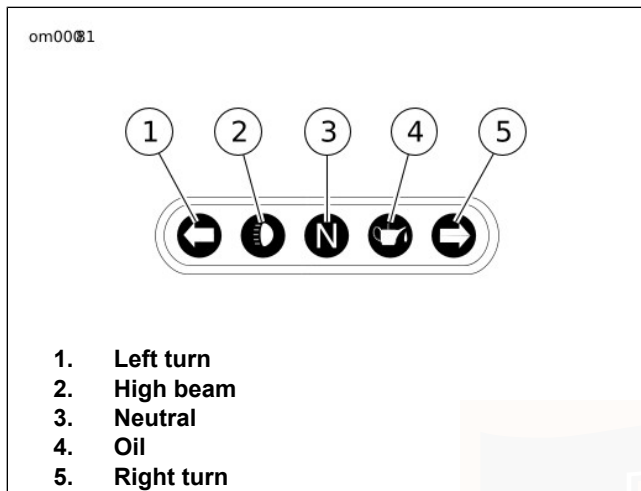

Figure 8. Indicator Lamps

INSTRUMENTS

Speedometer

⚠ WARNING

Travel at speeds appropriate for road and conditions and never travel faster than posted speed limit. Excessive speed can cause loss of vehicle control, which could result in death or serious injury. (00008a)

See Figure 9. The speedometer registers miles per hour (U.S. models) or kilometers per hour (international models) of forward speed. The speedometer also provides the following selectable functions:

- Odometer
- Trip odometers A and B
- 12 or 24 hour clock (if radio not installed)
- Fuel range function

The speedometer has a single display window for the above functions. If an Advanced Audio System is installed, the radio will provide the clock function.

1. See Figure 9. Pressing the function switch with the ignition switch in any position will activate the odometer reading and time. Time and mileage/kilometers may be checked without unlocking ignition switch. Press and release function switch once to view odometer. Press and release switch again to display time.
2. To check mileage on trip odometers, the ignition switch must be in the ACC or IGNITION position. Press and release the function switch until the desired trip odometer reading is displayed. An A or B in the upper left of the display window identifies trip odometers.

3. To reset or zero trip odometers, have desired (A or B) odometer in display window. Press function switch and hold switch for 2-3 seconds. The trip odometer will be reset to zero.
4. Repeat the previous step if you wish to zero both trip odometers.

Setting Clock

If the motorcycle is equipped with an Advanced Audio System, see the Advanced Audio System section in this manual to set the clock in the radio.

1. Turn the ignition switch to ACC or IGNITION.
2. See Figure 9. Press function switch until time (hour and minutes) is displayed. Press and hold the function switch for five seconds or until 12HR begins to blink in the speedometer display window. Release the button.
3. Press and release the function switch once to advance to a blinking 24HR or military style time display. Each time you press and release the button, the display will switch between 12HR and 24HR.
4. When the desired time style is displayed, press and hold the function switch for five seconds. The display will switch to the time display with the hours blinking.

NOTE

There is no AM or PM time setting required. So when correct hour is reached, press and hold function switch to advance to minute setting.

5. Press and release the function switch repeatedly to advance the hours. Each time you press and release the switch, the display will advance one hour.
6. When the correct hour is displayed, press and hold the function switch for five seconds. The minutes display will start blinking.
7. Press and release the function switch repeatedly to advance the minutes display. Each time you press and release the button, the display will advance one minute.
8. When the correct minutes are displayed, press and hold the function switch for five seconds. The minutes display will stop blinking, indicating that the clock has been set.
9. Turn the ignition switch OFF.

Tachometer

NOTICE

See **OPERATING RECOMMENDATIONS** section. Do not operate the engine above maximum safe RPM as shown under **OPERATION** (red zone on tachometer). Lower the RPM by upshifting to a higher gear or reducing the amount of throttle. Failure to lower RPM may cause equipment damage. (00159a)

See Figure 9. The tachometer measures the engine speed in revolutions per minute (RPM).

Tip Indicator Lamp

⚠ WARNING

If tip occurs, check all controls for proper operation. Restricted control movement can adversely affect the performance of the brakes, clutch or ability to shift, which could result in loss of vehicle control and death or serious injury. (00350a)

Should motorcycle be tipped over, the word "tip" will appear in the odometer window. Engine will not start until reset. To reset, cycle ignition/headlamp key switch ON-OFF-ON.

Fuel Gauge

The fuel gauge indicates the approximate amount of fuel in the fuel tank(s) and is located to left of the speedometer or on the left front panel of the fairing.

NOTE

The FLHR left side fuel cap is a fuel gauge only. Do not remove.

Oil Pressure Gauge

Some vehicles are equipped with an oil pressure gauge. The oil pressure gauge indicates engine oil pressure and is located on the fairing front panel. Engine oil pressure will normally vary from 34 kPa (5 psi) at idle speed to 207–262 kPa (30–38 psi) at 2000 RPM when engine is at normal operating temperature of 110 °C (230 °F).

Voltmeter

Some vehicles are equipped with a voltmeter. The voltmeter indicates electrical system voltage and is located on the fairing front panel. With the engine running above 1500 RPM, the voltmeter should register 13.0-14.5 volts with battery at full charge.

Air Temperature Gauge

Some vehicles are equipped with an air temperature gauge. This gauge indicates the ambient air temperature in degrees Fahrenheit. The gauge is located on the fairing front panel.

Fuel Range Function

The fuel range function shows the approximate mileage available with the amount of fuel left in the fuel tank.

1. With the ignition switch in the ACC or IGNITION position, press function switch until fuel range function is displayed, as indicated by the letter 'r' in the left side of the odometer display. The calculated remaining distance (miles or kilometers) to empty is displayed, based on the amount of fuel in tank. Range can be accessed at any time using the function switch.

2. When the low fuel warning lamp illuminates, the range feature will automatically be displayed in the odometer unless this automatic pop-up feature is disabled by a press and hold of the function switch while in range display mode. Automatic range pop-up feature will show that it is disabled by blinking twice. Likewise, automatic range popup can be reactivated by a press and hold of the function switch. Range will blink once when the automatic pop-up feature is re-enabled.

NOTE

- *When the low fuel warning lamp turns on, there is approximately 3.79 L (1.00 USgal) of fuel remaining in the tank. Refuel as soon as possible.*
 - *The range display is only updated when the vehicle is moving.*
3. After the range calculation reaches 16 km (10 mi) remaining, the range display will display "r Lo" to indicate that the vehicle will shortly run out of fuel.
 4. Resetting the low fuel warning lamp and range requires an ignition cycle change.

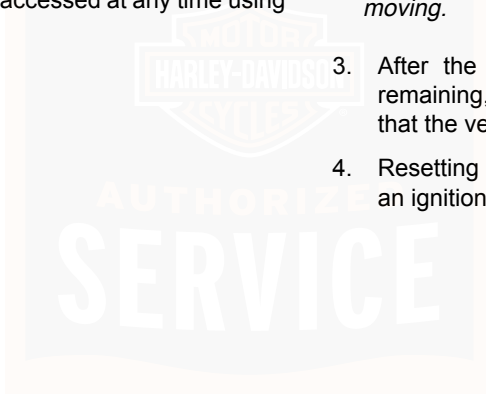

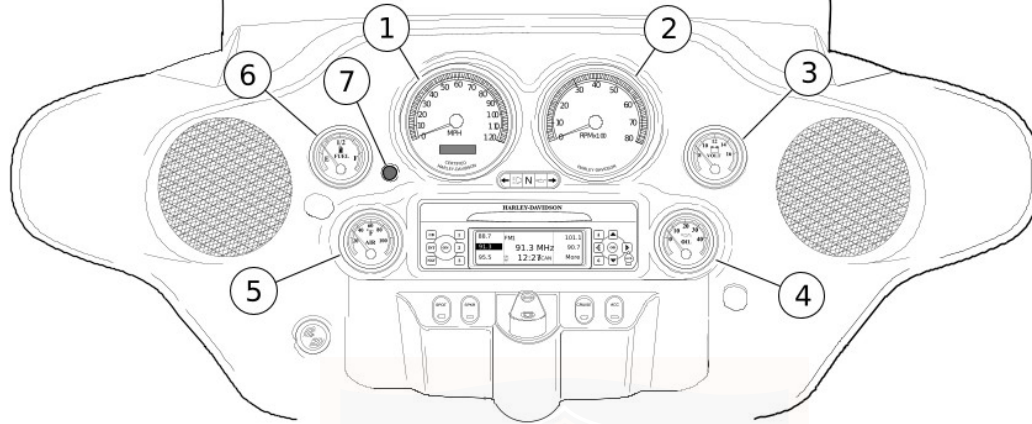

- | | |
|-----------------|--------------------|
| 1. Speedometer | 5. Air temperature |
| 2. Tachometer | 6. Fuel level |
| 3. Voltmeter | 7. Function button |
| 4. Oil pressure | |

Figure 9. Instruments (Typical)

INSTRUMENT LAMPS

Engine Check Lamp

See Figure 10. The engine check lamp is located along the bottom of the speedometer face. Its purpose is to indicate

whether the engine/engine management system is operating normally. The engine lamp color is amber.

The engine lamp normally comes on when the ignition is first turned on and remains on for approximately 4 seconds, as the engine management system runs a series of self-diagnostics.

If the engine lamp comes on at any other time, see a Harley-Davidson dealer.

Low Fuel Lamp

See Figure 10. The low fuel lamp is located in the speedometer face, lower center by check engine lamp. The low fuel lamp illuminates to indicate that you have approximately 3.8 L (1.0 USgal) of gasoline left in the tank. The low fuel lamp color is amber.

Battery Discharge Lamp

See Figure 10. The red battery charging lamp indicates either overcharging or undercharging of the battery. Refer to MAINTENANCE AND LUBRICATION > BATTERY: GENERAL (Page 178).

Cruise Control Equipped Models

See Figure 10. Cruise control equipped models feature two additional indicator lamps.

- An orange lamp on the cruise control switch which indicates the cruise control is ON or OFF.
- A green lamp on the tachometer (speedometer for FLHR models) face indicates the cruise control is SET or NOT SET.

Sixth Gear Lamp

See Figure 10. The sixth gear lamp on the speedometer face indicates when the transmission is in sixth gear.

Security System Lamp

See Figure 10. The red security system lamp on the speedometer face indicates when the security system is armed. Refer to HANDS-FREE SECURITY MODULE > HARLEY-DAVIDSON SMART SECURITY SYSTEM (Page 115).

ABS Lamp

See Figure 10. On ABS equipped models, the amber ABS indicator lamp begins to flash at key ON to indicate that the system is operational. It continues to flash until motorcycle speed exceeds 5 km/h (3 mph). Continuous illumination of the lamp will only occur when ABS detects that the system is malfunctioning. In the diagnostic mode, the lamp will also illuminate to indicate the presence of diagnostic trouble codes (DTCs). See a Harley-Davidson dealer for service.

⚠ WARNING

If ABS lamp continues flashing at speeds greater than 5 km/h (3 mph) or remains on continuously, the ABS is not operating. The standard brake system is operational, but wheel lock up can occur. Contact a Harley-Davidson Dealer to have ABS repaired. A locked wheel will skid and can cause loss of vehicle control, which could result in death or serious injury. (00361b)



om00706

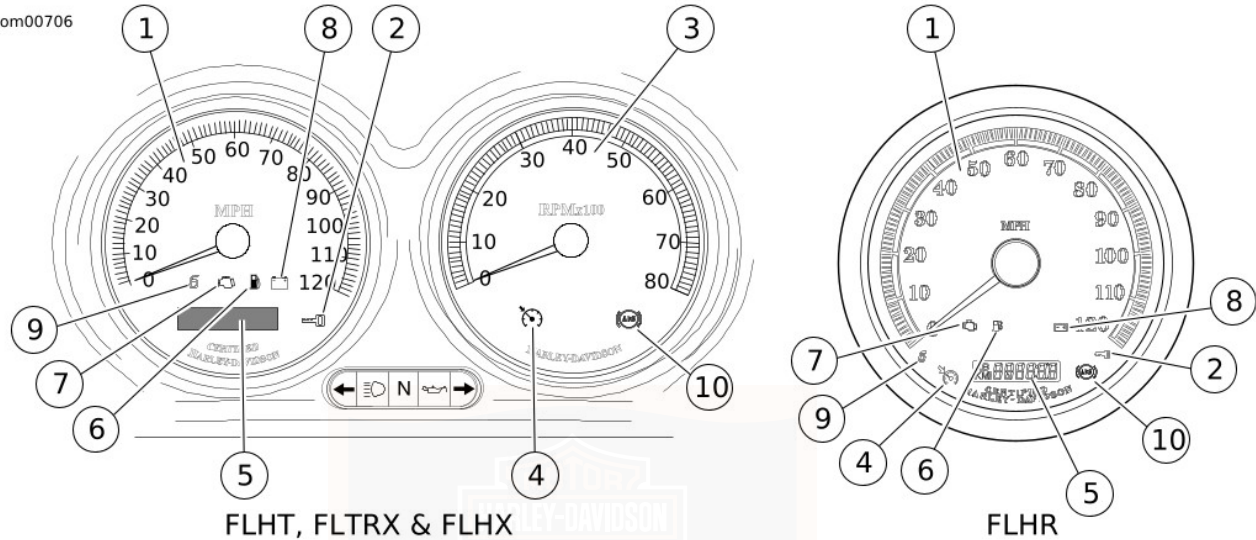

FLHT, FLTRX & FLHX

FLHR

- | | |
|---------------------------------|---------------------------|
| 1. Speedometer | 6. Low fuel warning lamp |
| 2. Security system lamp | 7. Engine check lamp |
| 3. Tachometer | 8. Battery discharge lamp |
| 4. Cruise lamp | 9. Sixth gear lamp |
| 5. Odometer/trip-odometer/clock | 10. ABS lamp |

Figure 10. Instrument Lamps

CRUISE CONTROL

NOTE

Touring Models are either equipped with cruise control or are cruise control ready. See a Harley-Davidson dealer for more information.

Operating Controls

The cruise control system provides automatic vehicle speed control.

⚠ WARNING

Do not use the cruise control system in heavy traffic, on roads with sharp or blind curves or on slippery roads of any kind. Using the cruise control in these circumstances can cause loss of control, which could result in death or serious injury. (00083a)

See Figure 11. A fairing cap cruise control switch located to the right of the ignition/headlamp key switch turns the cruise control system ON and OFF.

On FLHR models, the cruise control switch housing is on the left handlebar.

NOTE

The cruise control icon on the speedometer or tachometer will turn orange to indicate the cruise control is ON. If the orange icon does NOT come on, the system is NOT ON. You cannot SET cruise speed, see your dealer.

See Figure 12. RESUME/SET switch located in the right handlebar control group.

The RESUME/SET switch controls several system functions, including set, resume, accelerate and decelerate.

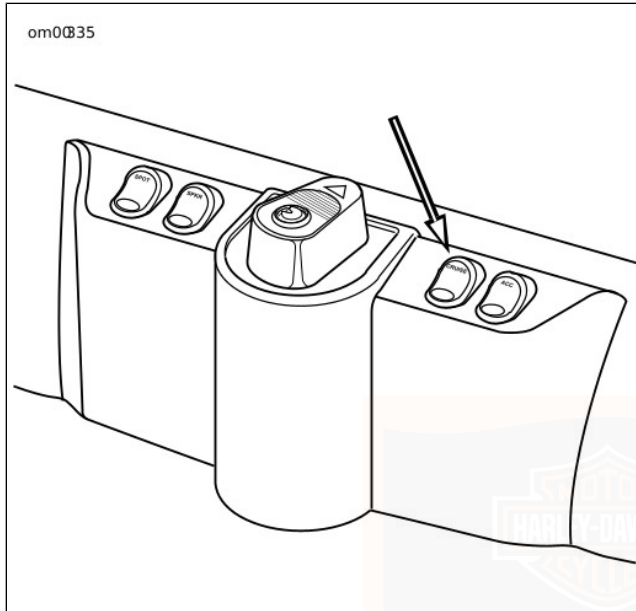

Figure 11. Cruise Control Fairing Cap Switch

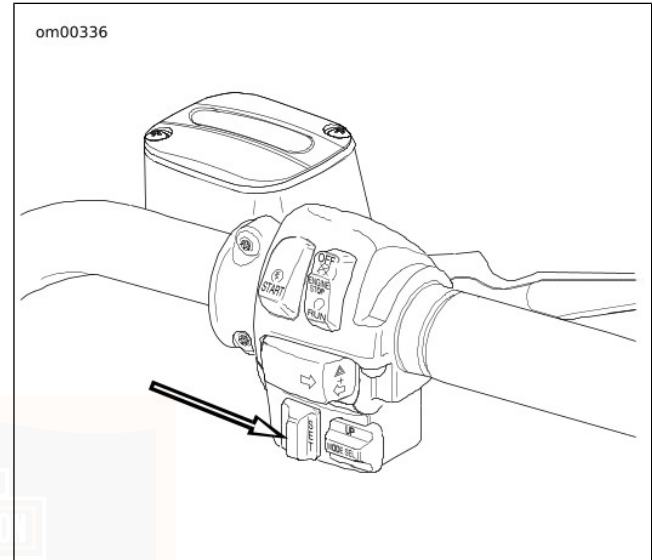

Figure 12. RESUME/SET Switch
CRUISE CONTROL OPERATION

Theory of Operation

The cruise control is designed to be safely operated with minimum movement by the rider and all rider control actions are natural and easy.

NOTE

- *The rider always over-rides and controls the system.*
- *The system will not work at vehicle speeds below 48 km/h (30 mph) or above 145 km/h (90 mph).*
- *The system is managed by the ECM. The tachometer provides information to disengage the system if the engine RPM suddenly increases.*
- *Besides the ECM, the system has other components: a stepper-motor (controlled by the computer) which operates the throttle during CRUISE operation, and several internal switches, all sending information to the computer.*
- *The system will allow rider to increase speed 16 km/h (10 mph) or more (depending on how hard the rider rolls on the throttle and the condition of the vehicle) over the SET point before deactivating. This feature allows the rider to momentarily increase speed, if necessary. Rolling on the throttle to greatly increase speed may deactivate the system.*

Engaging Cruise Control

1. See Figure 10. Turn the cruise control switch to the ON position. The orange icon on the cruise gauge face will light when activated.

2. With the motorcycle traveling at the desired cruise speed of 48–145 km/h (30–90 mph), momentarily push the RESUME/SET switch on the right handlebar to SET. After a delay of about 1-1/2 seconds, the icon will turn green on the face of the gauge to indicate the selected cruising speed is locked in.

Disengaging Cruise Control

The cruise control automatically disengages whenever the cruise control module receives one of the following inputs:

1. Front and/or rear brake is applied.
2. Throttle is rolled back or closed, thereby actuating roll-off (disengage) switch.
3. Motorcycle clutch is disengaged (module senses too great an increase in RPM).
4. Vehicle speed is out of the operating range.

NOTE

Rolling on the throttle more than 16 km/h (10 mph) above the set speed may also deactivate the cruise control.

When the cruise is disengaged, the green cruise engaged icon on the face of the gauge changes to orange. The orange cruise control system icon remains ON until the main switch is turned off.

However, should you decide to SET a cruise speed, RESUME last set speed, ACCELERATE or DECELERATE, simply press the RESUME/SET switch.

Resuming Cruise Speed

If the system is deactivated using one of the methods described under DEACTIVATING CRUISE CONTROL, the system is still ON should you decide to RESUME the set speed. To accomplish this, simply press the RESUME/SET switch to RESUME.

NOTE

The computer will hold the SET speed in memory for the RESUME function. If the vehicle speed drops more than 24 km/h (15 mph) below the SET speed, speed can no longer be RESUMED. If cruise operation is still desired, press the RESUME/SET switch to SET to reset the cruise speed.

Accelerating Above Cruise Speed

1. With the cruise speed set, momentarily press the RESUME/SET switch to RESUME to increase the speed by 1.6 km/h (1 mph).

2. Pressing and holding the RESUME/SET switch at RESUME will cause the system to continue to increase speed in increments of approximately 1.6 km/h (1 mph) until the switch is released. There is a delay of about 2 seconds before the speed increases.

Decelerating Cruise Control

1. With the cruise speed set, momentarily press the RESUME/SET switch to SET to reduce the speed by 1.6 km/h (1 mph).
2. Pressing and holding the RESUME/SET switch at SET will cause the system to continue to reduce speed in increments of approximately 1.6 km/h (1 mph) until the switch is released. There is a delay of about 2 seconds before the speed decreases.

Deactivating Cruise Control

Turn cruise control switch to the OFF position. The orange icon in the gauge is extinguished to indicate the system is OFF.

NOTE

System will NOT work if:

- *Rider operates at vehicle speeds below 48 km/h (30 mph) or above 145 km/h (90 mph).*
- *Brake lamps are on constantly. See dealer.*

Installing non-specified tires or gearing may affect cruise control operation.

GEAR SHIFT LEVER

NOTICE

The clutch must be fully disengaged before attempting a gear shift. Failure to fully disengage the clutch can result in equipment damage. (00182a)

The gear shift lever is located on the left side of the motorcycle and is operated with the left foot. The transmission is a six speed sequential gear box.

1. Push the gear shift lever all the way down (full stroke) to shift the transmission to the next lower gear.
2. Lift the gear shift lever all the way up (full stroke) to shift the transmission to the next higher gear.

NOTE

- *Release the gear shift lever after each gear change.*
- *The lever must return to its central position before another gear change can be made.*

First gear is the last gear position that can be found by pushing the gear shift lever full stroke downward.

Neutral is located between first and second gear. The green neutral indicator lamp on the dash will illuminate when the transmission is in neutral.

To shift from first gear to neutral, lift the gear shift lever 1/2 of its full stroke.

When the motorcycle is standing still and the engine is not running, shifting gears requires a different technique. Before shifting in this condition, move the motorcycle backward and forward with the clutch fully disengaged (clutch lever pulled in). While maintaining slight pressure on the shift lever, shift from one gear to another.

Even with the engine running and the motorcycle standing still, difficulty may be experienced in shifting gears. This difficulty occurs because transmission gears are not turning and shifting parts are not lined up to permit engagement.

NOTICE

When difficulty of shifting gears is experienced, do not under any circumstances, attempt to force the shift. The results of such abuse will be a damaged or broken shifter mechanism. (00161a)

See OPERATION > SHIFTING GEARS (Page 137) for more information.

HEEL-TOE FOOT SHIFTER

See Figure 13. Some motorcycles have a heel-toe shifter lever. With this shift lever, upshifts can be made with the heel of the left foot. Downshifts can be made with the toe.

- Pushing heel-toe foot shift lever all the way down (full stroke) shifts the transmission to the next lower gear.
- Lifting the foot shift lever all the way up (full stroke) shifts the transmission into the next higher gear.

Release the foot shift lever after each gear change. This allows the lever to return to its central position before another gear change can be made.

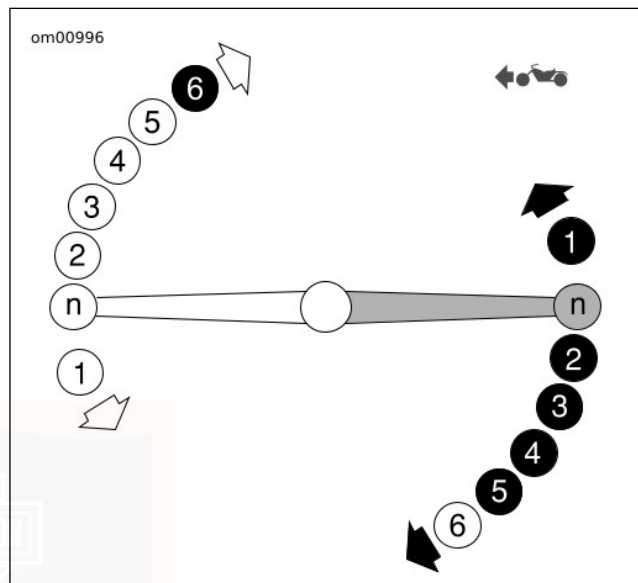

Figure 13. Heel-Toe Foot Shift Lever

BRAKE SYSTEM

General

The rear brake pedal controls the rear wheel brake and is located on the motorcycle's right side. Operate the rear brake pedal with the right foot.

The front brake hand lever controls the front wheel brake and is located on the right handlebar. Operate the hand lever with the fingers of the right hand.

▲ WARNING

Do not position fingers between hand control lever and handlebar grip. Improper hand positioning can impair control lever operation and cause loss of vehicle control, which could result in death or serious injury. (00032a)

Some models are equipped with an anti-lock braking system.

Non-ABS Brake System

Apply brakes uniformly and evenly to prevent wheels from locking. Use front and rear brakes equally for best results.

▲ WARNING

Do not apply brake strongly enough to lock the wheel. A locked wheel will skid and can cause loss of vehicle control, which could result in death or serious injury. (00053a)

Anti-lock Brake System (ABS)

Harley-Davidson's Anti-Lock Brake System assists the rider in maintaining control when braking in a straight-line

emergency situation. ABS operates independently on front and rear brakes to keep the wheels rolling and prevent uncontrolled wheel lock-ups either on dry pavement or on slick surfaces such as gravel, leaves or when riding in wet conditions.

ABS: How It Works

The ABS monitors sensors at the front and rear wheels to determine wheel speed. If the system detects one or both wheels are slowing down too quickly, which indicates they are close to locking, or if the deceleration rate does not match a criteria stored in memory, the ABS reacts. The system rapidly opens and closes valves to modulate the brake caliper pressure utilizing only the brake lever/pedal pressure being applied by the rider. During ABS activation, the system provides the electronic equivalent of manually pumping the brakes and is capable of cycling up to seven times per second.

The rider will recognize ABS activation by the slight pulsing sensation in the hand lever or the rear brake pedal. The pulsing sensation may also be accompanied by a clicking sound from the ABS module. Both are the result of normal operation. Refer to Table 21.

ABS: How To Use

While an advantage in emergency braking, ABS is not a substitute for safe riding. The safest way to stop a motorcycle is upright with both wheels straight.

Harley-Davidson ABS is a manual assist system. When in an emergency stopping situation, maintain pressure on the brakes through all ABS events. Do not modulate or "pump" the brake controls. The wheels won't lock until the end of the stop when motorcycle speed reaches approximately four miles per hour and ABS is no longer needed.

▲ WARNING

ABS cannot prevent lockup of rear wheel due to engine braking. ABS will not aid in cornering or on loose/uneven surfaces. A locked wheel will skid and can cause loss of vehicle control, which could result in death or serious injury. (00362a)

More information is available at www.harley-davidson.com/abs.

ABS: Tires and Wheels

ABS motorcycles must always use tires and wheels that are the same as the original equipment. The ABS monitors the rotational speed of the wheels through individual wheel speed sensors. Changing to different diameter wheels or different sized tires can alter the rotational speed. This can upset the calibration of the ABS and have an adverse effect on its ability to detect and prevent uncontrolled wheel lockups. Tire inflation pressure that is significantly low also can have an adverse effect.

Table 21. ABS Symptoms and Conditions

SYMPTOM	CONDITION
Pulsing brake lever or pedal during an ABS event	Normal condition.
Clicking sound during an ABS event	Normal condition.
ABS lamp flashing	Normal condition - key turned to IGNITION - speed under 5 km/h (3 mph).
Perceived "surge" while braking	Normal condition - most noticeable when braking with one brake (front only or rear only). Result of a reduction in deceleration which can be caused by cracks or bumps in road, engine braking (high engine RPMs causing the rear wheel to slow down), hard braking at slow speeds, and other conditions. This is due to ABS modulating caliper brake pressure to prevent uncontrolled wheel lock.

Table 21. ABS Symptoms and Conditions

SYMPTOM	CONDITION
Temporarily stiff rear brake pedal	Normal condition - engine braking (high engine RPMs causing the rear wheel to slow down) or down shifting can activate ABS. If applying the rear brake at the same time or immediately after, the ABS may be closing a valve to prevent pressure to the rear brake. This is due to ABS modulating caliper brake pressure to prevent uncontrolled wheel lock.
Tire chirp	Normal condition - depending on surface, tire can chirp without locking the wheel.
Black mark on pavement	Normal condition - depending on surface, tire can leave a black mark without locking the wheel.
Wheel lock at low speed	Normal condition - ABS will not activate on front wheel below 5 km/h (3 mph) or on rear wheel below 8 km/h (5 mph).

JIFFY STAND

⚠ WARNING

Always park motorcycle on a level, firm surface. An unbalanced motorcycle can fall over, which could result in death or serious injury. (00039a)

The jiffy stand is located on the left side of the motorcycle and swings outward to support the motorcycle for parking.

⚠ WARNING

The jiffy stand locks when placed in the full forward (down) position with vehicle weight on it. If the jiffy stand is not in the full forward (down) position with vehicle weight on it, the vehicle can fall over which could result in death or serious injury. (00006a)

⚠ WARNING

Be sure jiffy stand is fully retracted before riding. If jiffy stand is not fully retracted, it can contact the road surface causing a loss of vehicle control, which could result in death or serious injury. (00007a)

JIFFY STAND INTERLOCK: INTERNATIONAL MODELS

Some international models are equipped with a jiffy stand interlock feature.

The vehicle will start and run with the jiffy stand down while the transmission is in neutral. If the jiffy stand is down, the transmission is in gear, and the clutch is released, the vehicle will stall. The message "SidE StAnd" will scroll across the odometer to indicate this to the rider. Raising the jiffy stand (or putting the transmission in neutral) will permit the engine to run and clear the message.

If the jiffy stand falls out of the fully retracted position while riding at speeds greater than 15 km/h (10 mph), then the jiffy stand interlock system will maintain engine operation and alert the rider about this by illuminating the indicators (flash twice) and scroll the message "SidE StAnd" across the odometer. The message will remain until the system detects the jiffy stand in the fully retracted position again. The rider may continue to operate the vehicle while in this mode.

The rider may clear the text messages at any time by pressing the function switch once while the vehicle is powered up.

REAR VIEW MIRRORS

▲ WARNING

Objects in mirrors are closer than they appear. Use caution when judging distance of objects in mirrors. Failure to judge correct distances could result in death or serious injury. (00033a)

Your vehicle is equipped with two convex rear view mirrors.

This type of mirror is designed to give a much wider view to the rear than a flat mirror. However, cars and other objects seen in this type of mirror will look smaller and farther away than they actually are.

- Use caution when judging the size or relative distance of objects seen in rear view mirrors.
- Always adjust the rear view mirrors to clearly reflect the area behind the motorcycle before riding.

NOTE

Adjust mirrors so you can see a small portion of your shoulders in each mirror. This will help you establish the relative distance of vehicles to the rear of your motorcycle.

FUEL FILLER CAP

⚠ WARNING

Avoid spills. Slowly open fuel filler cap. Do not fill above bottom of filler neck insert, leaving air space for fuel expansion. Secure filler cap after refueling. Gasoline is extremely flammable and highly explosive, which could result in death or serious injury. (00028b)

NOTICE

Do not spill fuel onto the motorcycle while refueling. Immediately wipe up fuel spills on your motorcycle. Fuel can cause damage to cosmetic surfaces. (00147b)

NOTICE

Use only unleaded fuel in catalytic converter-equipped motorcycles. Using leaded fuel will damage the emission control system. (00150c)

To open, turn fuel filler cap counterclockwise and lift up. To close, turn fuel filler cap clockwise until it clicks. The ratchet action of the cap prevents overtightening.

NOTE

- See Figure 14. On FLHR/FLHRC models, the fuel filler cap is located on the right side of the fuel tank. The cap on the left side is the fuel gauge and is not removable.

- On all other models, the fuel filler cap is located beneath a locking door. Use the ignition key to unlock fuel door. The fuel filler cap should be fully closed before closing the fuel door.

See SAFE OPERATING RULES and review safety procedures listed below.

⚠ WARNING

Do not store motorcycle with gasoline in tank within the home or garage where open flames, pilot lights, sparks or electric motors are present. Gasoline is extremely flammable and highly explosive, which could result in death or serious injury. (00003a)

⚠ WARNING

Do not use aftermarket fuel caps. Aftermarket fuel caps may fit improperly and leak, which could lead to death or serious injury. See a Harley-Davidson dealer for approved fuel caps. (00034a)

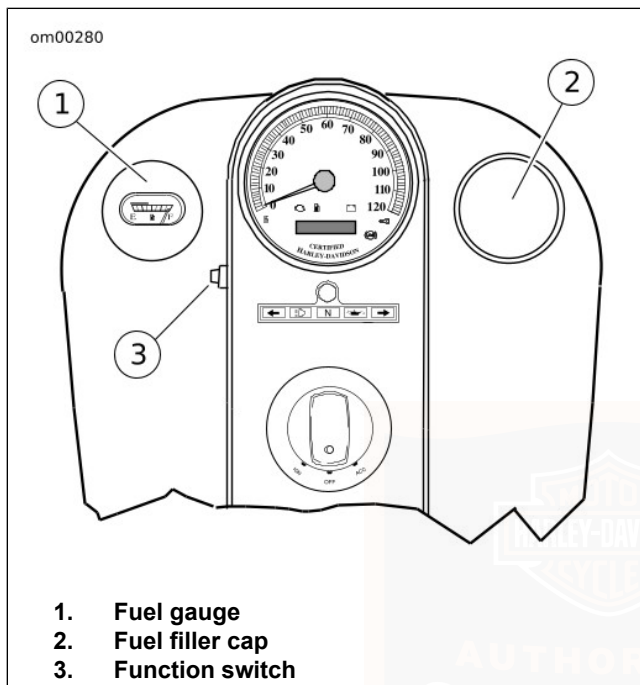

Figure 14. Fuel Tank: FLHR/FLHRC

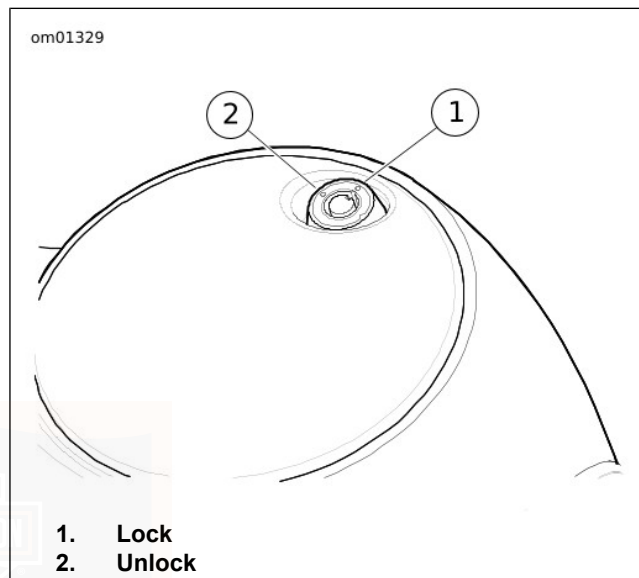

Figure 15. Fuel Door

REAR AIR SUSPENSION

All models feature air-adjustable rear suspension. Air pressure in the rear shock absorbers may be adjusted to suit load requirements, riding style and personal comfort.

NOTICE

Do not exceed maximum air pressure for suspension. Air components fill rapidly. Therefore, use low air line pressure. Failure to do so can result in possible damage to components. (00165b)

▲ WARNING

Use caution when bleeding air from the suspension. Moisture combined with lubricant may leak onto the rear wheel, tire and/or brake components and adversely affect traction, which could result in death or serious injury. (00084a)

1. Remove the left saddlebag, if present.
2. See Figure 16. Remove the cap from the air valve located behind the shock absorber on the left side of the vehicle.

NOTE

- *Always add 21–35 kPa (3–5 psi) to the existing pressure before releasing air from the system to prevent oil for exiting the air valve. NEVER exceed 345 kPa (50 psi).*
- *Do not exceed maximum GVWR or GAWR.*

3. Refer to Table 22 and Table 23. Attach AIR SUSPENSION PUMP AND GAUGE (PART NUMBER: HD-34633) to the air valve. Fill or release air from the shock absorber to the pressure specified for your model motorcycle and load.

NOTE

The specified pressures are recommended starting points. Adjust pressure to suit load conditions, riding style and comfort desired. Less pressure does not necessarily result in a softer ride. Using pressures outside the recommended loading range will result in a reduction of available suspension travel and reduced rider comfort.

4. Install cap on air valve and install left saddlebag, if removed.

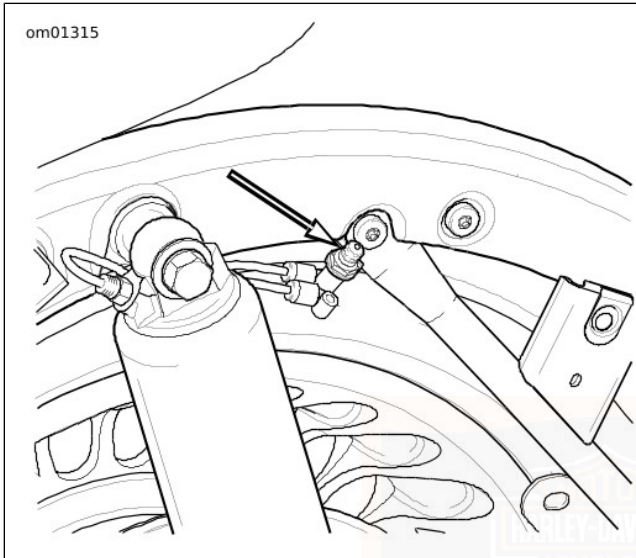

Figure 16. Rear Air Suspension Air Valve

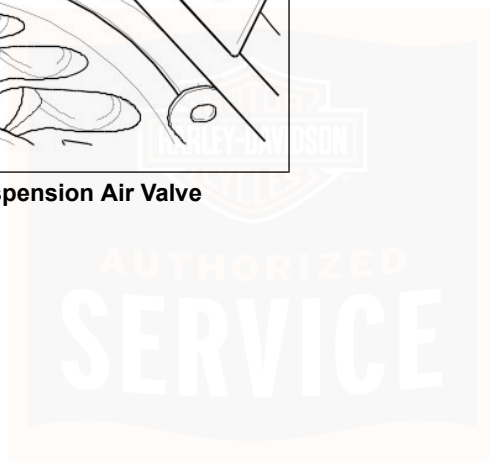

Table 22. Recommended Suspension Air Pressure: FLHX, FLTRX, FLHR/C

SHOCK LOAD	TOTAL WEIGHT		PRESSURE	
	LB.	KG	PSI	kPa
Solo rider	up to 150	up to 68	0	0
	150-200	68-91	0-10	0-69
	200-250	91-113	10-20	69-138
	250-300	113-136	20-30	138-206
	over 300	over 136	30-50	206-345
Solo rider with capacity luggage of 18 kg (40 lb)	up to 150	up to 68	10-20	69-138
	150-200	68-91	20-30	138-206
	200-250	91-113	30-40	206-276
	250-300	113-136	40-50	276-345
	over 300	over 136	50	345
Rider plus passenger	ALL	ALL	40-50	276-345
Maximum GVWR	ALL	ALL	50	345

If Tour-Pak is installed, add 34–69 kPa (5–10 psi) to shock pressure. Do **not** exceed 345 kPa (50 psi) suspension pressure.

Table 23. Recommended Suspension Air Pressure: FLHT/C/U, FLHTK

SHOCK LOAD	TOTAL WEIGHT		PRESSURE	
	LB.	KG	PSI	kPa
Solo rider	up to 150	up to 68	5-10	34-69
	150-200	68-91	10-20	69-138
	200-250	91-113	20-30	138-206
	250-300	113-136	30-40	206-276
	over 300	over 136	40-50	276-345

Table 23. Recommended Suspension Air Pressure: FLHT/C/U, FLHTK

SHOCK LOAD	TOTAL WEIGHT		PRESSURE	
	LB.	KG	PSI	kPa
Solo rider with capacity luggage of 32 kg (70 lb)	up to 150	up to 68	25-30	172-206
	150-200	68-91	30-40	206-276
	200-250	91-113	40-50	276-345
	over 250	over 113	50	345
Rider plus passenger	ALL	ALL	50	345
Maximum GVWR	ALL	ALL	50	345
Do not exceed 345 kPa (50 psi) suspension pressure.				

LUGGAGE

▲ WARNING

Do not exceed the motorcycle's Gross Vehicle Weight Rating (GVWR) or Gross Axle Weight Rating (GAWR). Exceeding these weight ratings can lead to component failure and adversely affect stability, handling and performance, which could result in death or serious injury. (00016f)

GVWR is the sum of the weight of the motorcycle, accessories, and the maximum weight of the rider, passenger and cargo that can be safely carried.

GAWR is the maximum amount of weight that can be safely carried on each axle.

The GVWR and GAWR is shown on the information plate, located on the frame steering head.

Make sure all storage compartments are secure before operating motorcycle.

Adhere to the weight limits and loading instructions on the labels within the storage compartments.

TOUR-PAK

Operation

See Figure 17. Some models are equipped with a lockable Tour-Pak. To open, unlock the Tour-Pak lock with the ignition key and open the draw catches.

Removal/Installation

⚠ CAUTION

Do **NOT** pull on any electrical wires. Pulling on electrical wires may damage the internal conductor causing high resistance, which may result in minor or moderate injury. (00168a)

The Tour-Pak can be installed in the forward or rearward position. See the service manual or a Harley-Davidson dealer for Tour-Pak removal/relocation.

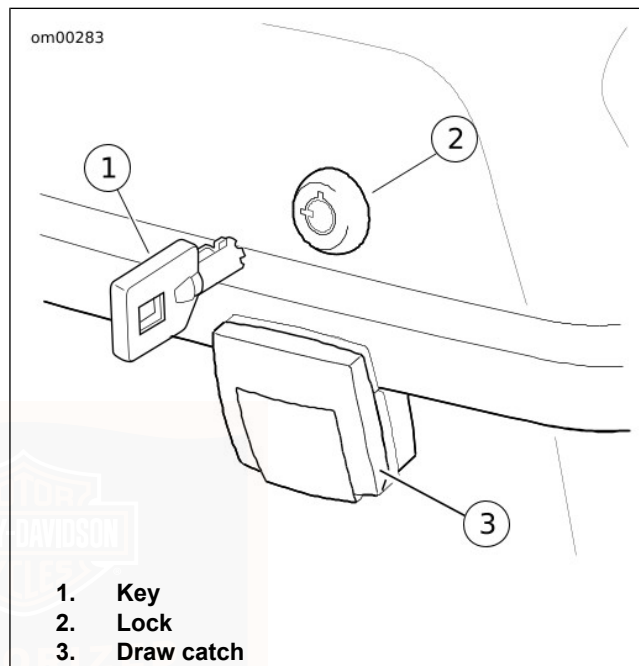

Figure 17. Tour-Pak Lock and Draw Catch

LEATHER SADDLEBAGS

Opening

See Figure 18. To use the quick disconnect strap feature, lift up the strap end to expose the quick release buckle and press on the lock tabs as shown.

The straps may also be opened and closed using the buckle in a conventional manner.

Closing

Insert the male strap end into the receptacle on the bag and push until a positive "click" is felt.

NOTE

See *CARE AND CLEANING > LEATHER CARE (Page 206)* for proper saddlebag care.

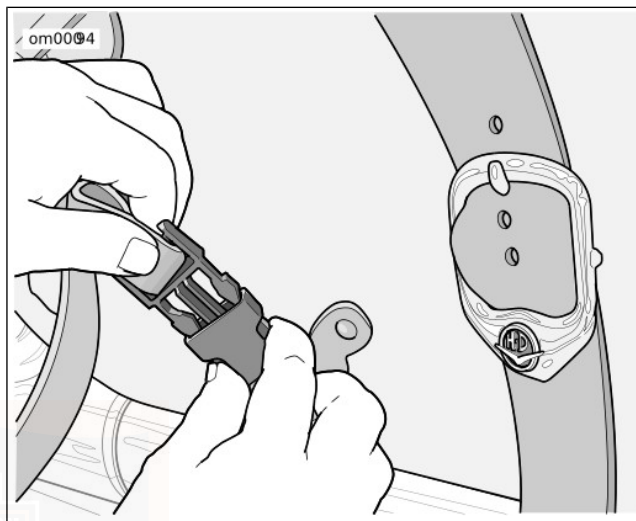

**Figure 18. Saddlebag Quick Disconnect
HARD SADDLEBAGS**

Opening

1. See Figure 19. Unlock latch using ignition key.
2. Place fingers under latch and lift.
3. Place one hand at OUTSIDE CORNER of cover and other hand at opposite outside corner.

4. Lift outside edge of cover, pivoting inside edge of cover in brackets.
5. Lift inside edge of cover to disengage brackets.
6. Bring cover towards you, over saddlebag.
7. As you bring cover toward you, let it flip over, so the inside faces up. Let cover rest against rub bars and nylon check strap.

NOTE

The saddlebag lids are designed to stay attached to the bags at all times.

Closing

1. See Figure 19. Use both hands to hold OUTSIDE corners of cover up and slide inside edge back into place so brackets slide together.
2. Close lid and secure latch. Brackets will engage automatically.

NOTE

Saddlebag latch and Tour-Pak draw catches should be closed and locked whenever motorcycle is in operation.

Removing

See Figure 19. The saddlebags are secured to the support brackets by 1/4 turn fasteners called bail head studs.

NOTE

If your vehicle (international only) does not have the wire form "bail", use a flat bladed screwdriver to turn the studs.

1. Rotate bail head studs 1/4 turn counterclockwise.
2. Remove saddlebag.

Installing

Carefully place saddlebag in position on saddlebag rail and align the bail head studs with the support bracket fasteners.

1. See Figure 19. Fasten studs by pushing into support bracket fasteners and turning 1/4 turn clockwise.
2. Check that studs are securely fastened.

Adjustments

If the latches become loose, you can adjust the latch fingers.

NOTICE

Adjust the latch fingers only enough to enable them to properly engage the latch hinge. Bending latch fingers back and forth can overstress the metal and weaken the fingers. (00169a)

1. Bend the fingers until they firmly engage the hinge.
2. See MAINTENANCE AND LUBRICATION > MISCELLANEOUS LUBRICATION (Page 156) for lubrication details.



om0074

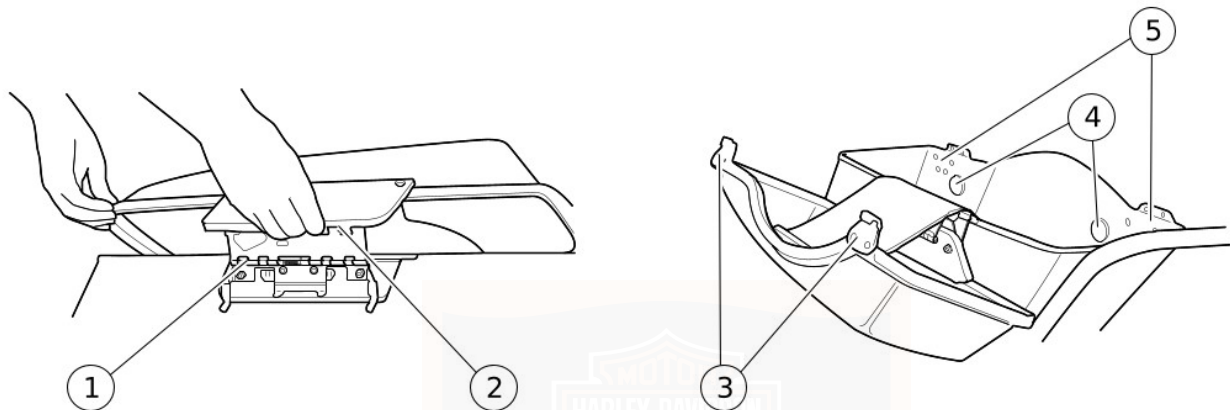

- 1. Hinge
- 2. Latch
- 3. Anchor tabs

- 4. Bail head studs
- 5. Anchor brackets

Figure 19. Hard Saddlebags

WINDSHIELD: FLHR/C

Removal

1. See Figure 20. Lift the wire form latch springs at either side of the windshield and move the TOP of the windshield assembly forward, until the TOP bracket notches slide away from the grommets.
2. Carefully lift the windshield bracket BOTTOM notches off the bottom grommets.
3. Remove windshield.

NOTE

For proper windshield maintenance, see CARE AND CLEANING > WINDSHIELD CARE (Page 208).

Installation

1. See Figure 20. Lift the wire form latch springs at either side of the windshield and slide the BOTTOM windshield bracket notches onto the bottom grommets.
2. Slide the TOP bracket notches onto the top grommets.

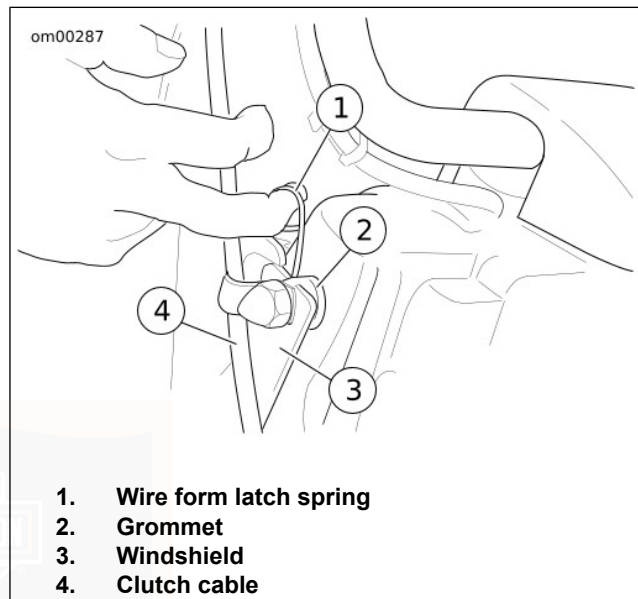

Figure 20. Windshield: FLHR/C

ADJUSTABLE AIR DEFLECTORS

See Figure 21. Some models are equipped with adjustable air deflectors located along the left and right bottom edge of the fairing. These deflectors can be rotated to direct airflow for rider and passenger comfort.

To adjust, grasp the outer edge of the deflector and pivot to the desired position.

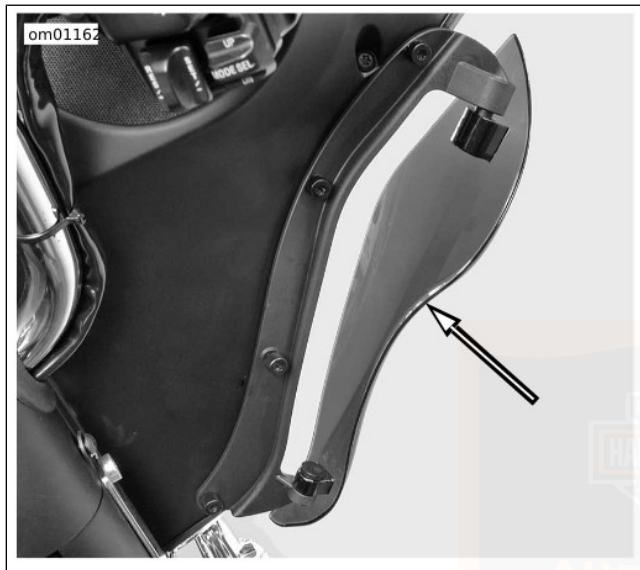

Figure 21. Adjustable Air Deflector

CIGARETTE LIGHTER

NOTICE

Do not use cigarette lighter socket to power electrical devices. Automotive electrical plugs can damage the socket, which can result in improper lighter operation and overheating that could cause equipment damage. (00599b)

See Figure 22. Some models are equipped with a cigarette lighter. The lighter is located on the left side of the fairing. To operate, press lighter into socket. The lighter will pop out when hot.



Figure 22. Cigarette Lighter

ACCESSORY SWITCH

The accessory switch controls power to the accessory connector under the seat. See a Harley-Davidson dealer for electrical accessories that may be purchased and installed on the motorcycle.

See Figure 23. On FLHR/FLHRC models, the accessory switch is on the left side of the nacelle.

See Figure 24. On all other models, the accessory switch is on the right side of the fairing cap.

NOTICE

It is possible to overload the vehicle's charging system by adding too many electrical accessories. If the combined electrical accessories operating at any one time consume more electrical current than the vehicle's charging system can produce, the electrical consumption can discharge the battery and cause damage to the vehicle's electrical system. (00211d)

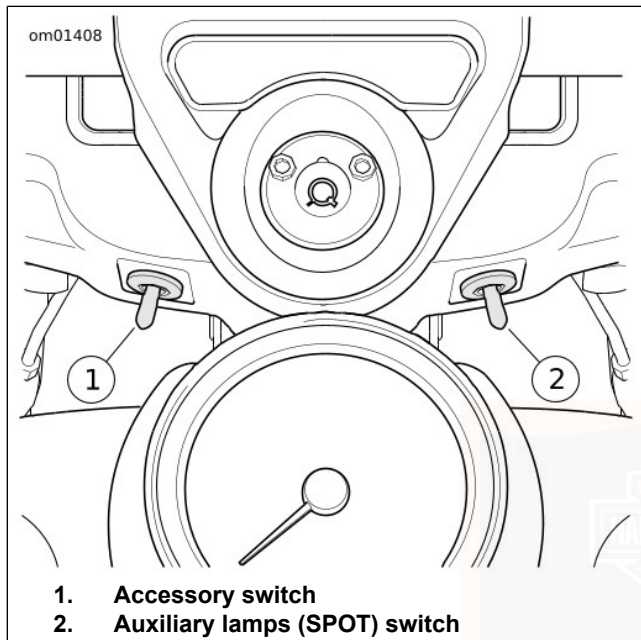

Figure 23. Nacelle Switches: FLHR/FLHRC

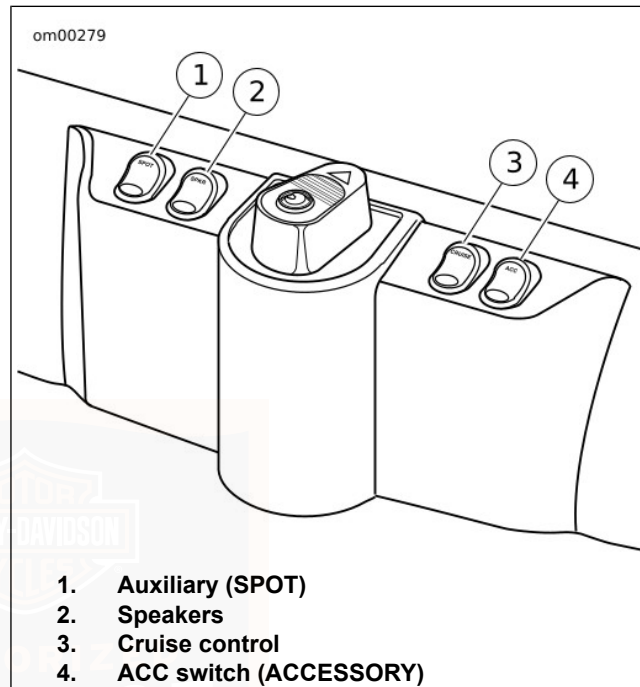

Figure 24. Switch Indicators

AUXILIARY LAMPS

Use the auxiliary lamp switch to turn on the auxiliary lamps as needed. When the high beam headlamp is turned on, the auxiliary lamps automatically turn off.

See Figure 23. On FLHR/FLHRC models, the switch is located on the right side of the nacelle.

See Figure 24. On all other models equipped with auxiliary lamps, the switch is located on the left side of the ignition/headlamp key switch on the fairing cap.

FAIRING LOWER VENTS

Some models are equipped with fairing lowers. The fairing lowers block wind and water from the rider legs, and include a compartment for storing small items.

See Figure 25. Vents in fairing lowers are controlled by the lever shown. Adjust vent openings to control air flow.

Fairing lowers may be removed in warmer ambient temperature to increase rider and passenger comfort.

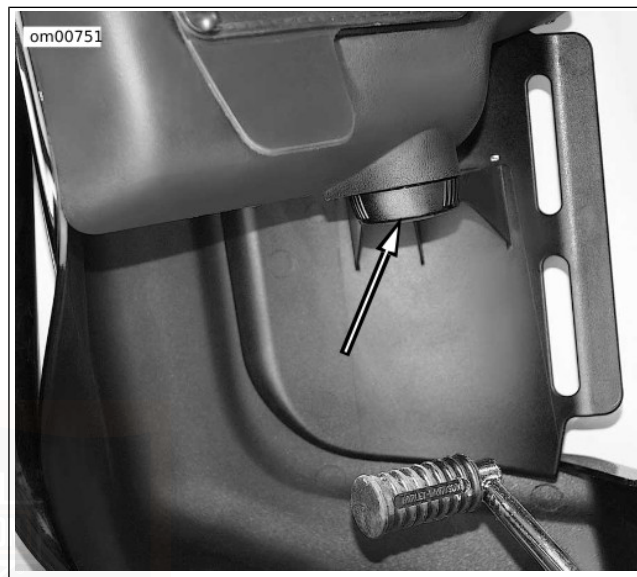

Figure 25. Fairing Lower Vent Control

PASSENGER FOOTBOARDS/FOOTRESTS

Passenger footboards/footrests can be adjusted to one of three positions. Before moving to a new position, remove plastic plugs from holes in the footrest mount in the frame as necessary.

1. See Figure 26. Remove socket screw with lockwasher from top of footboard/footrest bracket. Do not remove lower screw from footboards.
2. Place bracket at the desired position. Insert pin (on footrest bracket only) into mount hole.
3. Install socket screw with lockwasher. Apply a drop of Loctite Threadlocker 243 (blue) (Part No. 99642-97) to the threads. Tighten socket screw to 49–56 N·m (36–42 ft-lbs).

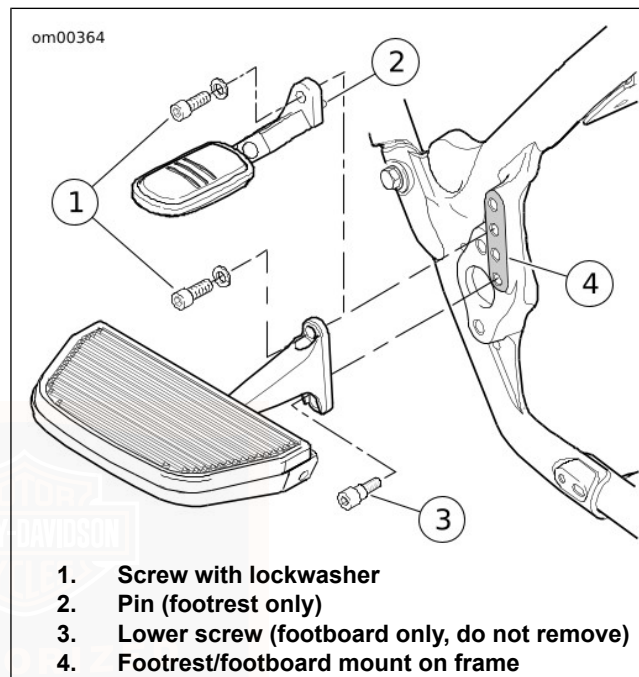

Figure 26. Passenger Footboard/Footrest (typical)

ADVANCED AUDIO SYSTEM

The Advanced Audio System by Harman/Kardon® is based on an electronic unit mounted inside the front fairing of selected Harley-Davidson Touring models.

For FLHX, FLHTC, and FLTRX: The Advanced Audio System is a multi-band radio receiver that includes a Compact Disc (CD)/MP3 player and an auxiliary (AUX) port for media players.

The receiver is stereo and plays through left and right speakers mounted in the rider fairing.

For FLHTCU and FLHTK: The Advanced Audio receiver also supports additional passenger speakers, a rider/passenger intercom and a 40 channel Citizen Band (CB) radio transceiver.

⚠ WARNING

Do not change compact discs while riding, and do not select a volume level that blocks out traffic noise. Distractions or a volume level that blocks out traffic noise, could cause loss of control resulting in death or serious injury. (00086a)

NOTICE

There are no serviceable parts inside the unit; leave all servicing to qualified service personnel. Disassembly of the unit could result in equipment damage and/or equipment malfunction. (00172a)

⚠ WARNING

Do not disassemble unit. Laser radiation is present if disc player is disassembled and the interlock fails or is defeated. Exposure to laser radiation could lead to death or serious injury. (00087a)

⚠ WARNING

Set volume levels and other controls on audio and electronic devices before riding. Distractions can lead to loss of control, resulting in death or serious injury. (00088b)

AUDIO SYSTEM QUICK START GUIDE

See the remaining information in this section for detailed information on all the features for the Advanced Audio System.

Radio Receiver

1. See Figure 27. With the ignition/headlamp key switch in IGNITION or ACCESS, press the **ON** button (10).

2. **Adjust Volume:** See Figure 28. Adjust volume with the the **AUDIO** switch (1) on the left hand grip. Push **AUDIO** switch up (+) to raise the volume or down (-) to lower the volume.
3. **Manual Tuning:** Press and hold the **Up Arrow** or **Down Arrow** until the desired radio frequency is displayed in the LCD (8).
4. **Preset Tuning:** Manually tune the radio to the desired station. Push and hold any one of the five soft keys (7 or 9).

Compact Disc (CD) Player

1. See Figure 27. Turn radio receiver ON, raise the CD door (2) and gently insert a CD with the label side up. The unit will automatically pull the CD into the player. Close the CD door.
2. **Change Tracks:** Push and release the MODE SEL switch on the right hand grip to select a specific track. Pushing the **Up Arrow** and **Down Arrow** (6) keys will also advance tracks.
3. Push the EJECT button (3) (located under the CD door) to eject the CD from the player.

Intercom - If Equipped

NOTE

Some local governments prohibit or restrict the use of headset (helmet-mounted) speakers. Check with local authorities and obey all applicable laws and regulations.

1. Plug headsets into front (Figure 33) and rear (Figure 35) headset jacks.
2. **Transmitting:** Press and hold either the rider PTT switch (Figure 28) or passenger PTT switch (Figure 35 to transmit. To end transmission, release **PTT** switch.

Citizen Band (CB) Radio - If Equipped

1. See Figure 27. Turn radio receiver ON and push the **COM** button (1). Push soft key **1** (9) to turn the CB ON/OFF.
2. **Select a Channel:** Push and release the MODE SEL switch on the right hand grip to select a CB channel.
3. **Transmitting:** Press and hold either the rider PTT switch (Figure 28) or passenger PTT switch (Figure 35 to transmit. To end transmission, release **PTT** switch.

STEREO RECEIVER

The Advanced Audio System stereo receiver is a radio (3 band maximum) with a full function Compact Disc (CD)/MP3 player and an auxiliary (**AUX**) input.

Auxiliary audio devices can play through the receiver's amplifier and speakers when connected to the **AUX** input port. Auxiliary devices include MP3 players, cassette players, and mini-disc players.

Receiver features include:

- Electronic single in-line CD/MP3 player with track up/down, forward and reverse scan, repeat and random play functions.
- CD/CDR/CDRW compatibility. Double-sided CDs will not play in this unit.
- MPEG 2.5 Level III (MP3) file format compatibility.
- More than 10 hours of MP3 music - 150 MP3 songs (10 albums) on one 650MB disc.
- Anti-skip protection (>40 second memory and mechanical dampers).
- Remote controls for frequency tuning, band change, CD select, volume, and bass/treble/fader mixing.
- Automatic Volume Control (AVC) - automatically adjusts volume to compensate for ambient noise due to motorcycle speed.
- Time-of-day clock.
- Weather band frequencies displayed as NOAA channel numbers (active on North American units only).

FRONT PANEL CONTROLS

See Figure 27. The front panel consists of a set of pushbuttons, a liquid crystal display, (LCD), a protective door for the Compact Disc (CD/MP3) slot and a covered input port for auxiliary (AUX) players. Six of the pushbuttons are "soft keys" whose function will change with the display.

ON

Press **ON** to turn the receiver on and off.

1, 2, 3, 4, 5/Left Arrow

For the stereo receiver, the soft keys, **1, 2, 3, 4, and 5/Left Arrow**, are used to store and then recall a selected radio frequency (pre-sets). When combined with any of the Advanced Audio System accessories, the function of any active soft key for that accessory will be displayed next to the soft key in the LCD display.

6

Pressing the **6** soft key will return the display to the previous menu. For **CB** and **Intercom Setup**, the function of the **6** soft key will be displayed in the LCD next to the **6** soft key.

5/Left, Up, Down, Right Arrows

The **5/Left, Up, Down,** and **Right Arrow** soft keys are used for radio band frequency tuning, Bass and Treble mixing, Fader and Volume. They are also used to scroll and highlight a selection in a list. For an Advanced Audio System accessory module, the arrow keys are active when arrows appear in the display.

OK

With a menu or list item highlighted, press the **OK** pushbutton to confirm the selection and initiate the function.

COM

Active on the FLHTCU/FLHTK or on motorcycles equipped the Advanced Audio System CB accessory, **COM** is the Citizen Band (CB) setup button. See ADVANCED AUDIO SYSTEM > CB OPERATION (Page 106). Press the **COM** pushbutton to display the CB Setup menu.

INT

Active only on the FLHTCU/FLHTK, **INT** is the intercom setup button. See ADVANCED AUDIO SYSTEM > INTERCOM OPERATION (Page 104). Press the **INT** pushbutton to display the Intercom Setup menu.

NOTE

With the headsets/microphones plugged into the rider and/or passenger intercom sockets, the intercom is voice activated (VOX).

NAV

Active only with the Advanced Audio System accessory, **NAV** is the GPS positioning and turn-to-turn navigation setup button. Press the **NAV** pushbutton to display the navigational menu.

LCD

The liquid crystal display (LCD) displays the operational status of the stereo receiver and that of any accessory.

CD Door

The CD door is a spring-loaded cover and will stay open when exchanging CDs.

Close the CD door after loading or unloading a CD. To close the door, push the door down until it latches.

EJECT

The CD **EJECT** button is found under the CD cover. Press the **EJECT** pushbutton to eject the CD.

AUX

The auxiliary input port under the **AUX** cover connects the receiver to an auxiliary device such as a cassette or MP3 player.

Use a 1/8 in. (3.5 millimeter) male to male extension cord to plug the line out or headset out from the auxiliary device into the **AUX** port. AUX appears in the LCD as a mode selectable with the **MODE SEL** switch.

The user has control of Bass, Treble, Fader and Volume, if so equipped, but all other player functions are performed with the auxiliary device. Set the volume level of the **AUX** device to normal or average.

NOTE

*Close the protective cap whenever the **AUX** port is not in use.*



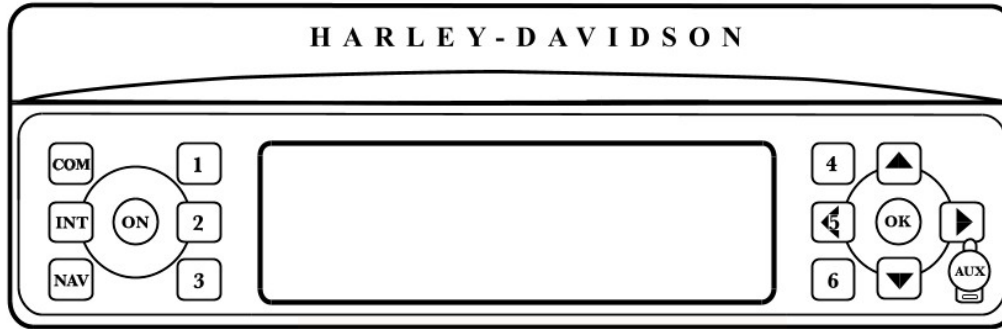

- | | |
|--------------------------------------------|-----------------------------------------|
| 1. Communications (CB) setup (if equipped) | 7. Soft keys (4, 5/Left Arrow, 6) |
| 2. CD cover | 8. Liquid crystal display (LCD) |
| 3. EJECT (under cover) | 9. Soft keys (1, 2, 3) |
| 4. OK (Confirm) | 10. ON key |
| 5. Auxiliary connector cover | 11. GPS navigation module (if equipped) |
| 6. Left (5), Up, Right, Down Arrow Keys | 12. Intercom setup (if equipped) |

Figure 27. Advanced Audio System Front Panel

LEFT HANDLEBAR CONTROLS

See Figure 28. Easy to operate while riding, audio controls are mounted on the left hand switch housing on the left handgrip.

For FLHX and FLHTC: The left hand audio control is an **+ /AUDIO/ -** switch.

For FLHTCU, FLHTK and FLTRX: The left hand audio controls are a **+ /AUDIO/ -** and a **PTT + /SQ/ -** switch. On FLTRX models, the **PTT + /SQ/ -** switch is inactive.

+ /AUDIO/ - Switch

AUDIO: See Figure 28. Press the **AUDIO** switch to access the Audio/Setup menu on the LCD. Press and release **AUDIO** or the press the soft key to toggle to the next displayed function in sequence from Bass, to Treble, to Fade, to Display, to Volume and then to to AVC.

If the **AUDIO** switch is left on any selection the function automatically reverts back to the selected mode after approximately 2-3 seconds.

±: Pressing the **AUDIO** switch upward (+) raises the level for the currently selected Audio/Setup (Bass, Treble, Fade, Volume or AVC). Pressing the switch downward (-) lowers the level. The level is raised or lowered as long as the switch is held until the minimum or maximum level is reached.

The LCD displays a horizontal dashed line to indicate the level. In the center of the line is a single thin dash. When the level is at the center, the selected audio is at a mid-point of its range.

The Fade function is only available on FLHTCU models. See C in Figure 37. Fade adjusts the balance between rider and passenger speakers. Pressing **AUDIO** upward (+) moves the balance to the front speakers while pressing **AUDIO** downward (-) moves the balance to the rear speakers. Equal volume in front and rear speakers is indicated by one horizontal single line in the center position.

The Display function sets the illumination level of the characters in the LCD display.

The AVC (Automatic Volume Control) function sets the volume level to compensate for the ambient noise associated with motorcycle speed.

PTT and + /SQ/ - Switch

See Figure 28. Push-To-Talk (**PTT**) and the squelch control switch (**+ /SQ/ -**) is located on the left handlebar switch assembly.

NOTE

*The **PTT** and **+ /SQ/ -** is found on the FLHTCU, FLHTK and FLTRX models. On the FLTRX, this switch is inoperative*

unless the optional Intercom and Citizen Band transceiver is installed.

PTT: With the power ON and the LCD indicating CB is active, press and hold the **PTT** switch to transmit over the channel displayed. Release **PTT** to end transmission.

+/SQ/-: Lower the threshold to allow reception of CB signals by pressing the **+/SQ/-** switch toward the rear (-) or raise the threshold by pressing the **+/SQ/-** switch toward the front (+).

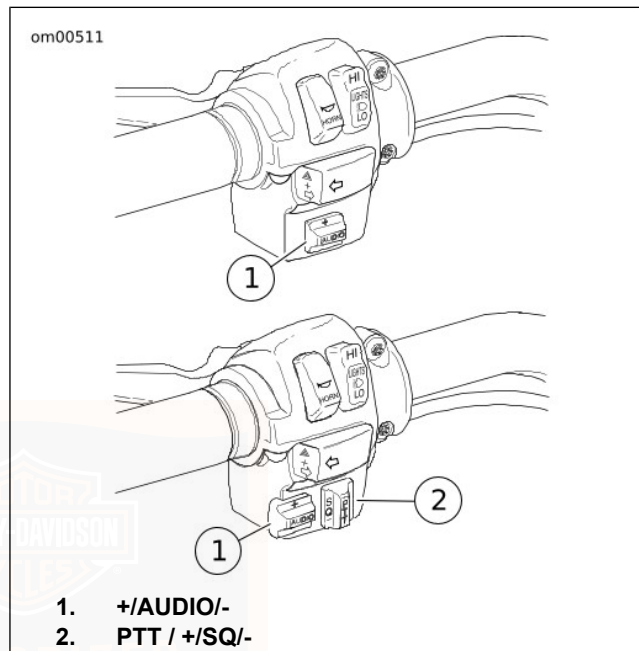

Figure 28. LH Audio Controls: FLHTC, FLHX Upper - FLHTCU, FLHTK, FLTRX Lower

RIGHT HANDLEBAR CONTROLS

See Figure 29. The mode select (**MODE SEL**) switch is located on the right handlebar switch assembly.

UP/MODE SEL/DN Switch

MODE SEL

With the radio power ON, press and release the **MODE SEL** switch to sequence between the radio bands.

When a audio CD/MP3 disc is inserted into the CD player the **CD** function is added to the selections. When a 3.5 mm (1/8 in) connector is plugged into the **AUX** input port the **AUX** function is added to the selections.

The LCD display indicates the function selected.

UP/DN

In the receiver mode: **UP/DN** allows up or down radio station SEEK tuning.

In CD/MP3 mode: **UP/DN** changes tracks and performs fast advance and fast reverse.

In the CB mode: **UP/DN** changes the CB channel.

In the Intercom mode: **UP/DN** changes the voice activated microphone (VOX) sensitivity.

In the AUX mode: The **UP/DN** switch is inactive.

For a detailed description of the various modes, see **ADVANCED AUDIO SYSTEM > RECEIVER OPERATION** (Page 86).

Table 24. Receiver Frequency Bands

MARKET	BAND	FREQUENCY	STEPS
Domestic	AM	530-1700 kHz	10 kHz
	FM	87.75-107.9 MHz	200 kHz
	WB	162.400-162.550 MHz	25 kHz
International	LW	144-279 kHz	3 kHz
	MW	531-1611 MHz	9 kHz
	FM	87.5-108 MHz	100 kHz
Japanese	MW	522-1629 MHz	9 kHz
	FM	76.0-91.0 MHz	100 kHz

NOTE

The intercom and CB can be activated at the same time with the receiver modes. The intercom and CB signals are passed to the audio circuits only if the signal strength exceeds the threshold established by CB squelch or VOX microphone sensitivity levels. Depending on the position of the speaker control switch in the fairing switch cap, the receiver function, the CB, and the VOX microphone can be heard in the headsets simultaneously. See **ADVANCED AUDIO SYSTEM > INTERCOM OPERATION** (Page 104) and **ADVANCED AUDIO SYSTEM > CB OPERATION** (Page 106).

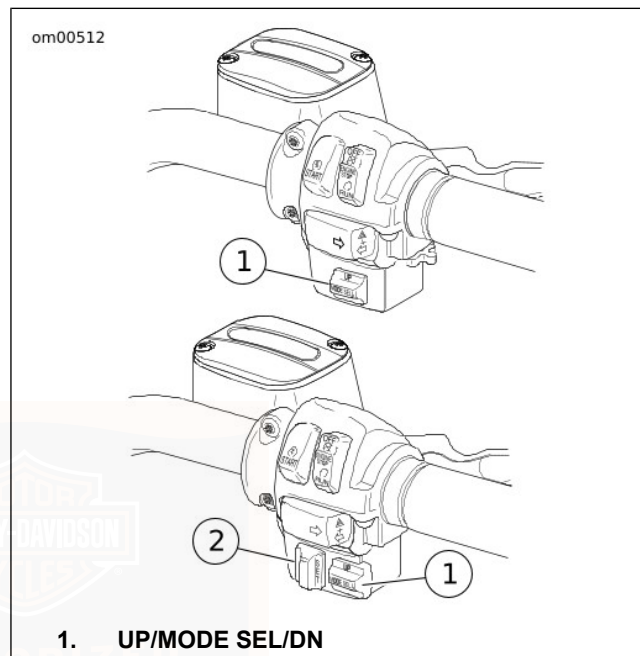

Figure 29. RH Audio Controls: FLHTC, FLHX (Upper) - FLHTCU, FLHTK, FLTRX (Lower)

RECEIVER OPERATION

See Figure 27 for an illustration of the stereo receiver front panel.

Set Time-of-Day

Set the time-of-day with the ignition/headlamp key switch turned to **IGNITION** or **ACCESS** but with the stereo receiver OFF.

Press the Set soft key (6) (Set) on the front panel to display the time setup menu.

See A in Figure 30. To increase the hours in the display press the Hrs+ soft key. To decrease hours press the Hrs- soft key. When the hour is correct, release the soft key.

To increase the minutes in the display press the Min+ soft key. To decrease minutes press the Min- soft key. When the minute is correct, release the soft key.

Turn Receiver ON/OFF

To turn the receiver ON, turn the ignition/headlamp key switch to **IGNITION** or **ACCESS** and press the **ON** button on the front panel. To turn the receiver OFF, press the **ON** button.

If the receiver is ON when the ignition is turned OFF, the receiver will power up when the ignition/headlamp key switch is turned to **IGNITION**.

Select a Frequency Band

Using the right thumb, press the **MODE SEL** switch on the right hand grip and release to cycle to the desired frequency

band (mode) or press the soft key next to the frequency band displayed in the LCD to select a frequency band.

See B in Figure 30. The LCD highlights the selected band.

NOTE

*Refer to Table 24. When a CD/MP3 disc is present in the CD slot and/or an auxiliary player is plugged into the AUX port, the **MODE SEL** switch will cycle through the CD and AUX modes as well as the frequency bands.*

Volume

See D in Figure 30. At any time the receiver is playing, the volume can be adjusted by pressing the **AUDIO** switch up (+) to increase volume or down (-) to decrease volume.

AM vs FM Reception

Commercial radio broadcasting is either AM (Amplitude Modulation) or FM (Frequency Modulation).

AM

AM radio waves reflect off the ionosphere which results in consistent signal reception at a long range (up to 100 miles or 160 kilometers).

However, AM radio can be displaced by loud humming, popping and crackling noises. This is electrical interference

caused by noise from vehicle ignitions, electric signs, power lines and electrical storms.

FM

The advantages of FM radio are high fidelity sound, stereo reception, a wide range of broadcasting formats and a signal that is free of electrical interference.

The disadvantage of FM radio is its short range. FM radio waves travel in straight lines, called "line-of-sight," therefore, FM signals cannot be received over the horizon. At the limit of a station's range, the reception may fade in and out when objects pass between the transmitter and the motorcycle.

FM Stereo vs FM Mono

See E in Figure 30. Normally, the Advanced Audio System plays FM signals in stereo. The LCD will indicate **STEREO**.

However, the stereo receiver has circuits which eliminate or minimize FM flutter due to weak stereo signals. The circuits detect a weak FM stereo signal and automatically blend it into a stronger FM mono signal. The transition is smooth and flutter-free because it occurs over a range of signal conditions, rather than at a minimum threshold.

When the system is automatically blending or is receiving an FM mono signal, the stereo indicator (**STEREO**) will disappear from LCD screen.

WB

See H in Figure 30. Broadcast by the National Oceanic and Atmospheric Administration (NOAA) National Weather Band (WB) frequencies are available in North America only.

To receive NOAA weather alerts while listening to other radio bands, highlight the Alert indicator in the WB display by pressing the soft key. An alert tone will automatically switch the receiver to the announcing WB channel regardless of which frequency band is playing.

When equipped with the CB module, use the soft key to highlight the Alert indicator in the LCD display. Weather alerts are announced over other audio and the **Alert** indicator is highlighted in the display.

Tuning a Radio Station

The radio has several tuning modes in each of the frequency bands: Manual, Seek, Scan, Preset Memory and Preset Scan.

Tuning in all three modes continuously wraps around the ends of the band.

Manual Tuning

To manually tune the radio to a different frequency:

Press the **Up Arrow** button or the **Down Arrow** button to select the frequency in that direction. Hold the selected arrow

button, and after a short delay of 1.5 seconds, the radio will continue to change frequencies until the selected arrow button is released.

SEEK Tuning

See E in Figure 30. In SEEK, the radio tunes in to the next strong station.

Press and release the **MODE SEL** switch up (**UP**) to tune in the next strong station upward in the band. Press and release the switch down (**DN**) to tune in the next strong station downward in the band.

NOTE

The SEEK icon appears in the display as long as the receiver is seeking the next strong frequency. The SEEK icon disappears as soon as the receiver has tuned in the next station.

SCAN Tuning

In SCAN, the radio continuously tunes from one strong station to the next until the SCAN is cancelled.

See F in Figure 30. Press and hold the **MODE SEL** switch **UP** or **DN** approximately 5 seconds to scan the band for strong station signals. Each strong station remains tuned in for 8

seconds before the radio scans to the next station. The receiver will continue to scan until cancelled.

To select a station, cancel SCAN while the radio is tuned to that station. Press the **MODE SEL** switch **UP** or **DN** to cancel a SCAN moving up the band.

Preset Memory Tuning

Use the soft keys, **1, 2, 3, 4,** and **5/Left Arrow** as preset buttons to store frequently tuned stations.

NOTE

See C in Figure 30. AM can store 6 preset frequencies.

*See E and F in Figure 30. Separate FM1 and FM2 bands allow the rider to store 2 sets of 5 preset FM frequencies (10 total). Use the **More** soft key to toggle between FM1 and FM2. The full range of FM frequencies can be selected in either FM1 or FM2.*

To store a current station, press and hold any one of the preset buttons for 1.5 seconds. After an audible signal (a chirp), the station's frequency has been stored and the frequency will appear in the display next to the preset soft key.

To tune to a stored station, press and release the preset soft key.

Preset SCAN Tuning

See G in Figure 30. In preset SCAN, the radio continuously tunes from one preset station to the next until the preset SCAN is cancelled. A P.SC icon will display while preset SCAN is active.

In the FM band, press and hold the More soft key for approximately 3 seconds. Each preset station remains tuned in for 10 seconds before the radio moves to the next station.

To select a station, cancel preset SCAN while the radio is tuned to that station. Press the **MODE SEL** switch **UP** or **DN** to cancel a preset SCAN.

Adjusting Volume

Volume can be adjusted in any radio band.

See D in Figure 30. Volume is adjusted with the **AUDIO** switch on the left hand grip. Using left thumb, press the **AUDIO** switch up (+) to raise the volume or down (-) to lower the volume. The LCD displays the word Volume and a bar graph that changes length with the volume.

Press the **MODE SELUP** or **DN** to cancel the Audio/Setup display or wait 5 seconds after the **AUDIO** switch is released, the display switches to the currently selected frequency band.

See K in Figure 30. Volume can also be adjusted in Audio/Setup.

Press and release the **AUDIO** switch to enter the Audio/Setup display. Press and release the **AUDIO** switch to cycle through Bass, Treble, Fade and Display to Volume and the **AUDIO** switch to raise (+) or lower (-) the volume.

Mixing Bass and Treble

Bass and treble range adjustments can be applied to any Advanced Audio System source.

BASS: See I in Figure 30. Press **AUDIO** to display Bass Audio/Setup. Using the left thumb, press the **AUDIO** switch up (+) to increase the bass range or down (-) to lower the bass range. The LCD displays the word Bass and a dashed line that changes length with the setting. The short center dash indicates a middle setting.

TREBLE: See J in Figure 30. From Bass Audio/Setup, press and release **AUDIO** to sequence to Treble. Using the left thumb, press the **AUDIO** switch up (+) to increase the treble range or down (-) to lower the treble range.

See J in Figure 30. The LCD displays the word Treble and a bar graph that changes length with the setting. The short center dash indicates a middle setting.

Adjusting AVC

See L in Figure 30. Automatic Volume Control (AVC) automatically adjusts volume level to compensate for ambient noise associated with motorcycle speed.

If the AVC does not adequately compensate for ambient noise (or if it over compensates), enter the audio setup menu and select AVC. Compensation is adjusted with the **AUDIO** switch

on the left hand grip. Using left thumb, press the **AUDIO** switch up (+) to raise the compensation level or down (-) to lower the compensation.

NOTE

Although the receiver AVC is preset at 3 bars, it is adjustable from zero bars (OFF) to four bars. At one bar, the volume does not change with motorcycle speed. The more bars displayed, the higher the volume increases with speed.



om00501

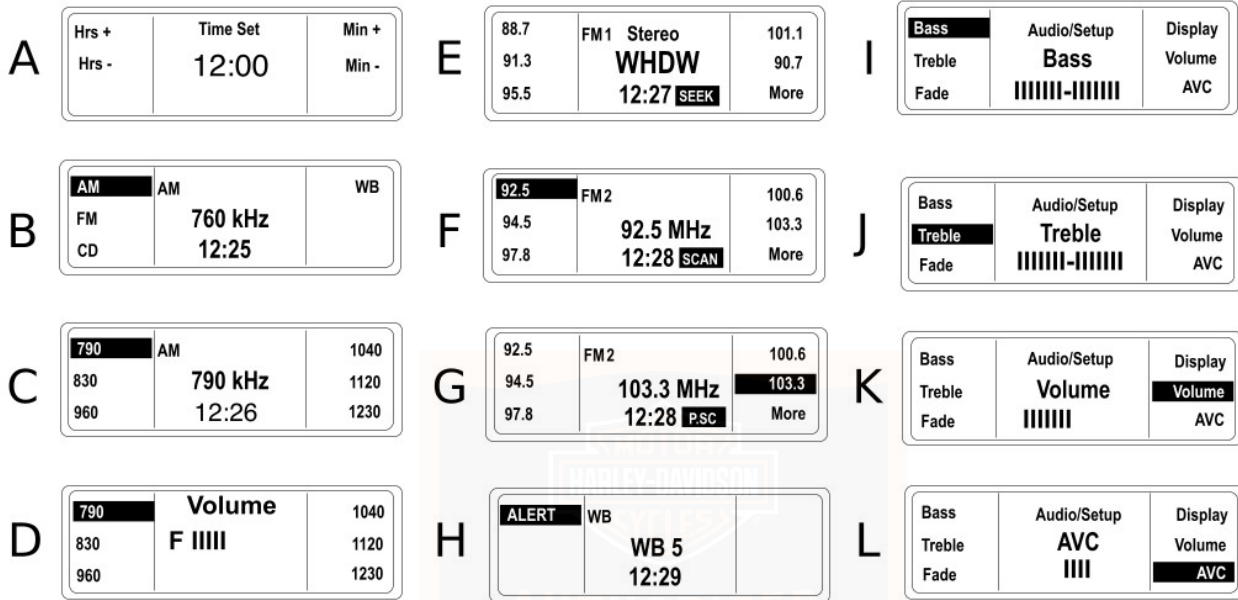

Figure 30. FLHX, FLHTC and FLTRX LCD Display Examples

Adjusting Display Contrast

See Figure 31. Select Display from the Audio/Setup menu with the **AUDIO** switch. Press the **AUDIO** up (+) to increase or down (-) to decrease the contrast of the characters in the display.

NOTE

The contrast can be decreased to render the characters invisible against the background. The characters will appear to have disappeared in the display. Before leaving the Display screen, always increase the character illumination to make the characters visible in other modes.

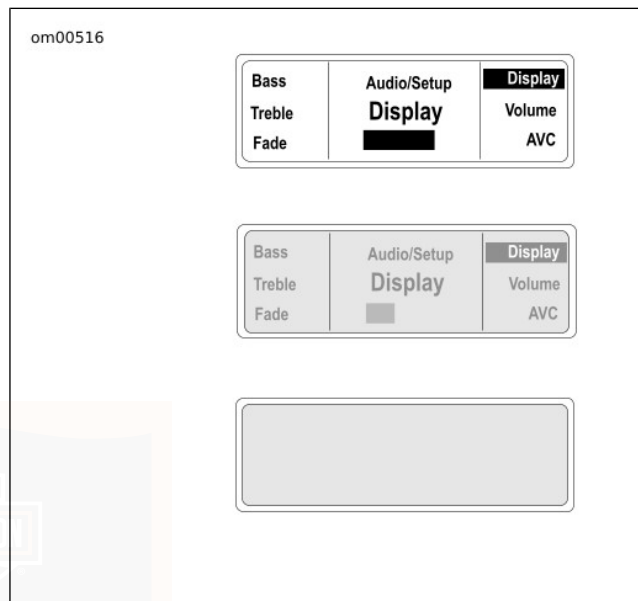

Figure 31. Character Display Illumination

CD/MP3 OPERATION

The CD player will accept commercial audio discs as well as compact discs recorded with MP3 (MPEG 2.5 Level III), files on compact disc read only (CDR) or compact disc read and write (CDRW) formats.

NOTICE

There are no serviceable parts inside the unit; leave all servicing to qualified service personnel. Disassembly of the unit could result in equipment damage and/or equipment malfunction. (00172a)

⚠ WARNING

Do not change compact discs while riding, and do not select a volume level that blocks out traffic noise. Distractions or a volume level that blocks out traffic noise, could cause loss of control resulting in death or serious injury. (00086a)

⚠ WARNING

Do not disassemble unit. Laser radiation is present if disc player is disassembled and the interlock fails or is defeated. Exposure to laser radiation could lead to death or serious injury. (00087a)

Auto Load

With the receiver power ON, raise the CD door and gently insert a CD, label side up, into the CD slot until the unit automatically pulls the CD into the player. Close the CD door.

NOTE

Do not use double sided CDs in the Advanced Audio stereo receiver. Double-sided CDs may become permanently lodged in the player.

See C in Figure 32. The receiver will automatically switch to CD operation. The CD track number and play time will appear in the LCD display. With a CD in the player, CD is added to the modes selectable with the **MODE SEL** switch.

⚠ WARNING

Set volume levels and other controls on audio and electronic devices before riding. Distractions can lead to loss of control, resulting in death or serious injury. (00088b)

Disc Error 1

See B in Figure 32. If the CD loaded into the CD player is damaged, of incorrect format, or upside down, the LCD will display the Disc Error 1 message.

Eject the CD. Refer to **ADVANCED AUDIO SYSTEM > RECOMMENDATIONS FOR HANDLING CDS** (Page 97).

Eject

▲ WARNING

Do not change compact discs while riding, and do not select a volume level that blocks out traffic noise. Distractions or a volume level that blocks out traffic noise, could cause loss of control resulting in death or serious injury. (00086a)

Press the **EJECT** button found under the CD door to eject a CD. The CD will be partially ejected. Remove the CD. Close and latch the CD door.

The receiver will automatically return to the radio band and frequency playing when the CD was loaded and the CD mode is no longer selectable.

Tracks

To change CD/MP3 tracks, use the right thumb and press and release the **MODE SEL** switch on the right hand grip. Press **UP** and release to select higher numbered tracks or press **DN** and release to select lower number tracks.

Pressing the **Up Arrow** and **Down Arrow** keys will also advance tracks.

NOTE

The player automatically numbers the MP3 files found on a CD in alphabetical order.

*If the **MODE SEL** switch is pressed and held **UP** or **DN** longer than 1.5 seconds, the track selections will fast advance or reverse as long as the switch is held.*

CD track selection wraps around the first and last track.

Fast Advance and Reverse

To fast advance a track, press the **MODE SEL** switch **UP** and hold longer than 1.5 seconds. The current track will fast advance while the switch is pressed **UP**. The audio will advance to the subsequent track as long as the switch is held **UP**.

See D in Figure 32. The play time display in the LCD will also fast advance.

To fast reverse a track, press **MODE SEL DN** and hold longer than 1.5 seconds. The current track will fast reverse while the switch is pressed **DN**.

The play time display in the LCD will also fast reverse.

Random

To play tracks randomly, press the Random soft key on the front panel while in the CD mode. The word Random will remain highlighted in the display. No selection is repeated until all other selections have been played.

NOTE

*The Random soft key toggles between normal and Random play. Press once for random play. Press a second time to return to normal play. Pressing the **MODE SEL** switch **UP** or **DN** will select different tracks at random.*

See D in Figure 32. Random will be highlighted in the display.

Scan

To scan the tracks on an CD/MP3 disk, press the Scan soft key.

NOTE

The tracks will play for 8 seconds and then jump to the next track which will play for 8 seconds.

Upon selecting a track, press and release the **MODE SEL** switch to continue playing that track.

Repeat

To repeat a CD track while it is playing, press the soft key next to the Repeat display.

To cancel Repeat, press the Repeat soft key again or press the **MODE SEL** switch **UP** or **DN** to change tracks.

Repeat will no longer be highlighted in the display.

MP3

The receiver CD player will automatically recognize and play MP3 files.

NOTE

The files will be numbered sequentially.

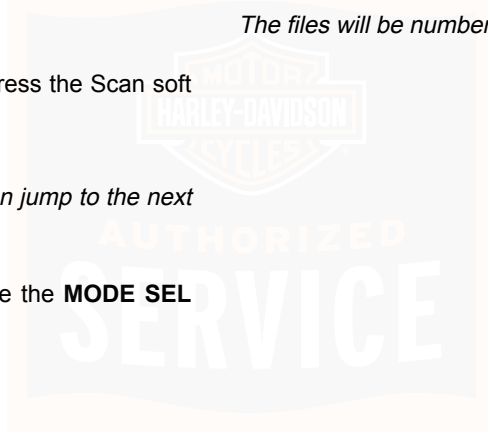

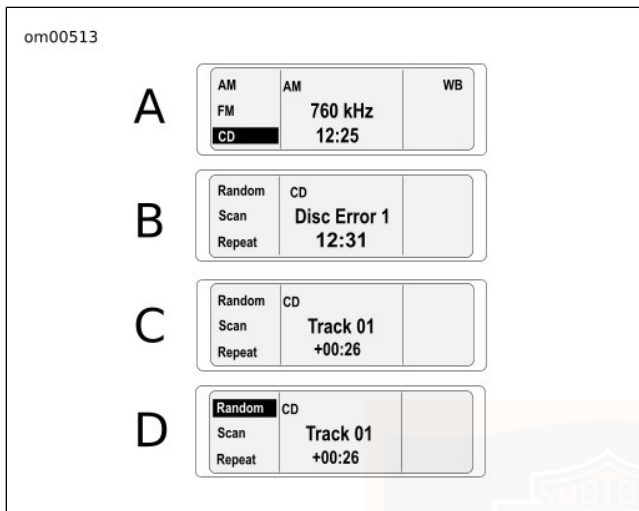

Figure 32. CD/MP3 Display Examples

RECOMMENDATIONS FOR HANDLING CDS

- Use caution when handling a CD. Avoid touching the bottom (shiny) side.
- Store audio CD/MP3 discs in acrylic jewel cases to protect against dust, scratches, light, and changes in humidity.
- Store CDs in a cool dry place away from direct sunlight.
- Use commercially available cleaning tissue to clean the CDs. Never use solvents that can damage the CD.

- Keep protective CD door closed at all times.

▲ WARNING

Do not disassemble unit. Laser radiation is present if disc player is disassembled and the interlock fails or is defeated. Exposure to laser radiation could lead to death or serious injury. (00087a)

NOTE

- *A laser that cannot focus properly may cause skipping. A clouded lens can be caused by dirty CDs, dust, smoke, high humidity, and airborne particles may cause the laser lens to cloud. Operating the CD without allowing the motorcycle to warm up can also cause a CD to skip.*
- *Do not attempt to clean the lens with a cleaning disc. Commercially available cleaning discs may cause damage or become stuck in the CD player.*

INTERCOM AND CITIZEN BAND WITH PASSENGER SPEAKERS

FLHTCU/FLHTK includes a digitally tuned 40 channel Citizen Band (CB) transceiver and rider/passenger intercom.

Features include:

- Rider headset connector on fuel tank console.
- Passenger headset connector on backrest.

- Handlebar mounted rider push to talk (**PTT/+SQ/-**) switch (CB and Intercom).
- Fairing-mounted speaker switch.
- Rear-mounted passenger **UP/MODE SEL/DN** and **PTT/+VOL/-** switches (CB and Intercom).
- Digitally adjustable rear headset speaker volume.
- Passenger receiver band switching and frequency tuning.
- Passenger CD/MP3 player control.
- Rider hand-held microphone compatibility for areas that prohibit headset (helmet-mounted) speakers.

HEADSETS AND SOCKETS

NOTE

Some local governments prohibit or restrict the use of headset (helmet-mounted) speakers. Check with local authorities and obey all applicable laws and regulations.

A Harley-Davidson dealer can help you select the correct genuine Harley-Davidson headsets and microphones for your year and model Harley-Davidson. Harley-Davidson stereo helmet headsets with 7-pin DIN jacks fit the rider and the passenger intercom sockets. Other headset microphones will not work.

Open the socket cap and with the ridge on the headset jack facing upward and insert the jack into either the front or rear headset socket.

NOTE

For areas that do not permit headset speakers, a special hand-held microphone can be used to transmit over the CB. This microphone is also available through a Harley-Davidson dealer.

NOTICE

Do not pull on the cord to remove the headset from the socket. Pull on the headset jack to disconnect the headset from the socket. (00174a)

The spring-loaded hinge keeps the headset socket cap closed while riding. It protects against dirt and water when the headset or hand-held microphone is not in use. Before washing the motorcycle, verify that **BOTH** rider and passenger socket caps are closed.

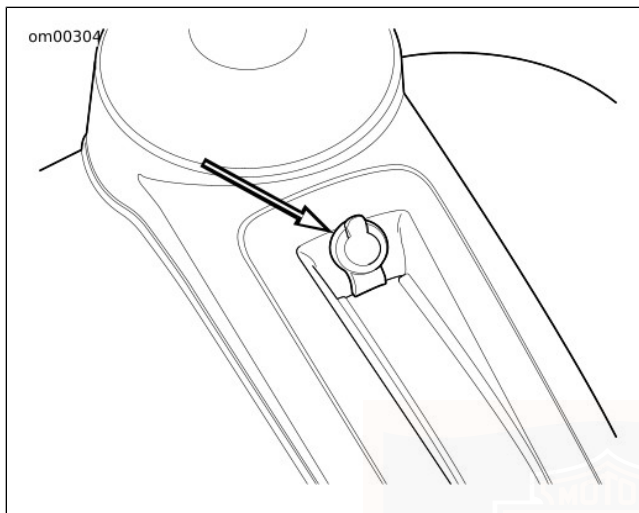

Figure 33. Front Headset Socket Cap

VOX MICROPHONES

The Harley-Davidson intercom uses a voice-activated (VOX) microphone for hands-free intercom operation. The headset microphone minimizes the transmission of hand-held microphone generated noise.

The intercom is activated when a voice or sound exceeds a preset audio level, the voice is said to "break VOX". The voice or sound is transmitted to the headsets.

NOTE

Pressing and holding the **PTT** switch will also open the microphone.

Once VOX is broken, a conversation can proceed uninterrupted. After the absence of sound or voice, there is a delay of approximately 2 seconds before the microphone is deactivated. This delay in deactivation allows for pauses in conversation.

Because loud exhausts, passing trucks, car horns or other background sounds may unintentionally activate the intercom, the sound level necessary to break VOX is adjustable. See **ADVANCED AUDIO SYSTEM > INTERCOM OPERATION** (Page 104).

SPEAKER CONTROLS

SPKR Switch

A three position speaker (SPKR) switch is located on the inner fairing cap of the FLHTCU/FLHTK/FLTRX. See Figure 34.

NOTE

The **SPKR** switch found on the **FLTRX** is inoperable.

Off/Forward: In the forward position, the speakers are off. Audio (radio, CD/MP3, AUX and CB) is played in the headsets

only. During simultaneous CB reception, the other audio source is muted and only the CB is heard in the headsets.

Center: In the center position, the radio, CD/MP3 player or AUX is played over the speakers while the CB is played only in the headsets.

On/Rearward: In the rearward position, the speakers are on. With the SPKR indicator lit, the radio, the CD/MP3 player, or any AUX device and the CB are played through both the rider and passenger speakers. When a CB signal is received, other audio sources mute and the CB is played over the speakers. Refer to Table 27.

NOTE

The intercom is only heard in the headsets, regardless of the SPKR switch position.

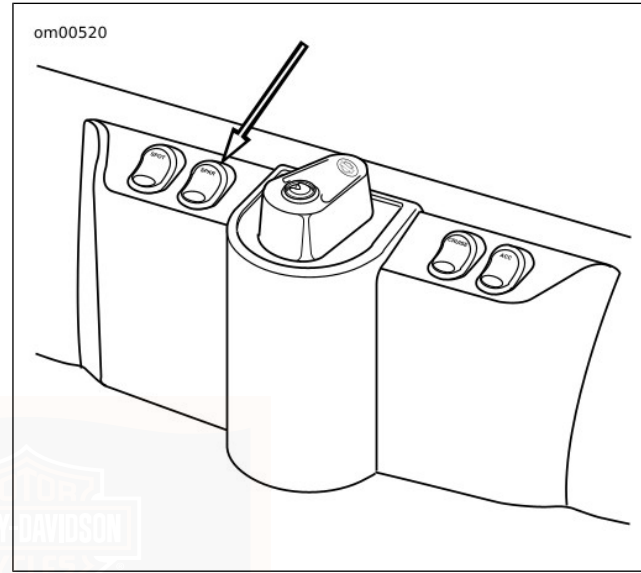

Figure 34. SPKR Switch

Rider to Passenger Speaker Balance

The receiver FADER control balances the front rider and rear passenger speakers.

NOTE

FADER is available only on the FLHTCU/FLHTK, equipped with rider front and passenger rear speakers.

FADER: With the fairing speaker switch in either the SPKR or center position, press the **AUDIO** switch to cycle through Bass to Treble to Fade in the LCD. Or with the motorcycle stationary, press the left hand **AUDIO** switch once to enter the Bass display and select Fade with the **MODE SEL** switch or with the soft key.

The LCD displays the word Fader and a row of outlined rectangles. The smaller center rectangle indicates equal balance between front and rear speakers. A single solid rectangle moves left or right of the center dash as the balance of volume is switched from the passenger speakers (to the left) to the rider speakers (to the right). See C in Figure 37.

- Press the AUDIO switch up (+) to raise the volume from the rider speakers while lowering the volume from the passenger speakers.
- Press the AUDIO switch down (-) to raise the volume from the passenger speakers while lowering the volume from the rider speakers.

PASSENGER CONTROLS

UP/MODE SEL/DN Switch

See Figure 35. The passenger **MODE SEL** switch on the left side of the speaker box gives the passenger control of radio band selection, tuning, CD/MP3 operation and all functions of the hand grip mounted **MODE SEL** switch.

NOTE

For information on routing audio signals to the passenger speakers and headsets, refer to Table 27.

PTT and +/VOL/- Switch

See Figure 35. The **PTT+/VOL/-** switch on the right side of speaker box allows the passenger to talk over the intercom or transmit over the CB as well as to raise or lower the rear headset volume.

See E in Figure 37. When the rear headset volume is adjusted, a F (front) and R (rear) bar graph appear in the LCD display.

NOTE

- *The passenger VOL switch affects only the passenger headset. The handlebar mounted **AUDIO** switch is the master volume control, and used in conjunction with the FADER, affects both the rider and passenger speaker volume.*

- With stereo receiver tuning, radio band selection, CD/MP3 track selection or other functions, simultaneous use of front and rear **MODE SEL** switches may cause operation to be suspended until either rider or passenger controls are released.

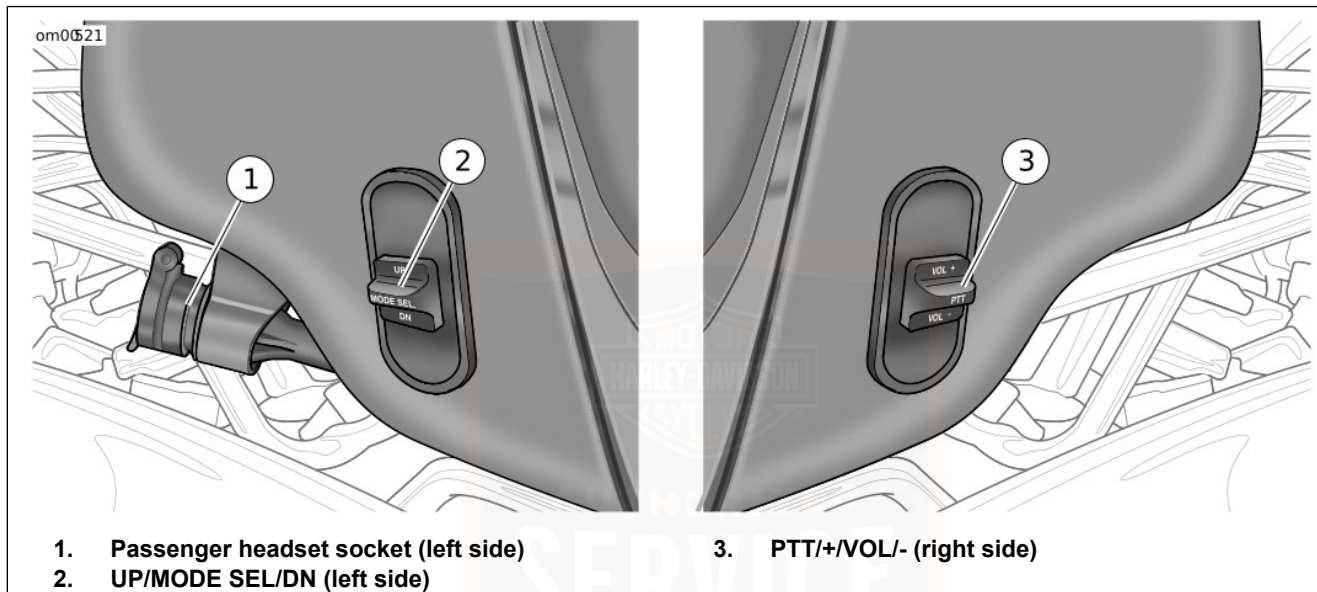

Figure 35. Passenger Controls

SIDECAR CONTROLS

See Figure 36. A **MODE/+TUNE/-** press and tilt switch, a **PTT/+VOL/-** press and tilt switch and a headset socket are mounted on the dash of the TLE Ultra sidecar for the FLHTCU/FLHTK. These controls and stereo speakers of the sidecar are connected to the Advanced Audio System through a wire harness.

MODE and +/TUNE/- Switch

The **MODE/+TUNE/-** switch controls radio band selection, station tuning, and CD/MP3 track selection and operation. The **MODE/+TUNE/-** switch operates like the hand grip mounted **UP/MODE SEL/DN** switch.

PTT/+VOL/-

The **PTT/+VOL/-** press and tilt switch controls the volume in the sidecar speakers and headset and is used to open the intercom and transmit over the CB.

Pressing the **PTT** switch left (+) raises the volume level for the currently selected Audio. Pressing the switch right (-) lowers the volume level.

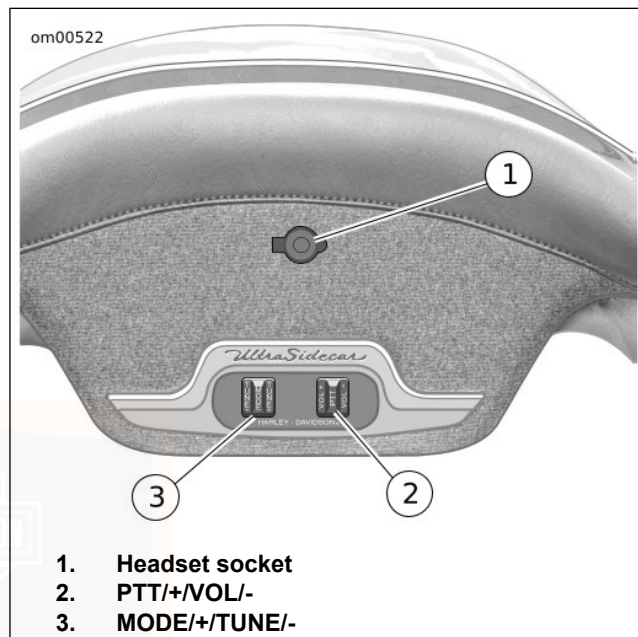

Figure 36. TLE Ultra Sidecar Audio Controls

Table 25. Speaker Output Power

MODEL	TOTAL WATTS	SPEAKERS	OHMS PER SPEAKER
FLTR FLHTC	40	2 speakers, 20 watts each	2
FLHTCU	80	4 speakers, 20 watts each	2
TLE Side- car w/amp- lifier	40	2 speakers, 20 watts each	2

INTERCOM OPERATION

Operation

To speak over the intercom, press and hold either rider or passenger **PTT** switch to enable the microphones. Both microphones are active while one or both **PTT** switches are pressed.

NOTE

Always verify that the CB is off so that private intercom conversations will not be transmitted.

Activating the Intercom and the VOX Microphones

Press and hold the **INT** button on the front panel, to open the Intercom Setup display.

See D in Figure 37. To activate the intercom (INT) and the VOX microphones, press soft key **1** to turn the intercom ON.

The intercom will activate in Intercom Setup with VOX sensitivity and headset volume level settings from the previous use. VOX sensitivity and headset volume are adjusted in Int Setup only.

To exit Int Setup, press and release the **MODE SEL** switch or the **INT** button.

To make adjustments to VOX sensitivity after exiting Intercom Setup, re-enter Intercom Setup by pressing **INT**.

NOTE

To ensure privacy, the intercom can only be heard through the headsets.

To turn OFF the intercom and the VOX microphones, press the **INT** button to open the Intercom Setup display and press the On/Off soft key (**1**).

Adjusting VOX Sensitivity

VOX sensitivity should be adjusted so that the microphones break VOX at a normal voice level.

Enter Intercom Setup by pressing the **INT** button. Press the **ON** or **1** soft key to turn the intercom on.

See G in Figure 37. Press the **MODE SEL** switch **UP** or **DN** or press the **4** or **5** soft key to initiate the VOX display. The LCD displays VOX sensitivity as a bar graph with a smaller bar to indicate the center of the 14 bars. A higher number of bars indicates greater sensitivity while a lower number means less sensitivity.

Continue to use **MODE SEL** on the right hand grip to adjust the sensitivity level. Press **MODE SEL UP** to make the microphone more sensitive. Press the **MODE SEL DN** to reduce sensitivity. To exit Setup, press and release the **MODE SEL** switch.

NOTE

- *The receiver retains the sensitivity level from the previous setup. However, if power is removed from the receiver, VOX sensitivity defaults to mid level.*
- *VOX sensitivity may have to be adjusted if either microphone is unintentionally activated because the microphone misinterprets radio, road or background sound as conversation.*

When VOX is set to its maximum, the microphone is always open. The VOX display will read Open.

When VOX is set to lowest value, the microphone is closed and the VOX display reads Closed.

Adjusting Rider Headset Volume

The rider intercom volume is only adjustable in Intercom Setup.

See E in Figure 37. Enter Intercom Setup, speak into microphone and adjust the intercom volume with the **AUDIO** switch on the left hand grip. Press **AUDIO +** to raise the volume and **AUDIO -** to lower the volume. The LCD displays a dashed line that changes length with the level.

See F in Figure 37. When the headset volume has been adjusted to the bottom of its range, Mute will appear in the volume display.

To exit Intercom Setup, press and release the **MODE SEL** switch.

▲ WARNING

Set volume levels and other controls on audio and electronic devices before riding. Distractions can lead to loss of control, resulting in death or serious injury. (00088b)

Adjusting Passenger Headset Volume

The passenger intercom volume is only adjustable in Intercom Setup.

Enter Intercom Setup. Speak into the microphone and adjust the intercom volume with the **AUDIO** switch on the right speaker box on the passenger's backrest. Press **AUDIO +** to raise the volume and **-** to lower the volume. The LCD displays a bar graph that changes length with the level.

See F in Figure 37. When the headset volume has been adjusted to the bottom of its range, Mute will appear in the volume display.

To exit Intercom Setup, press and release the **MODE SEL** switch or press the INT pushbutton.

CB OPERATION

Activating the CB

See H and I in Figure 37. To activate the Citizen Band transceiver, press and release the **COM** pushbutton on the front panel. Press soft key **1** to turn the CB ON/OFF. The CB will activate in CB Setup with squelch threshold and channel settings from the previous use. CB channels are selected in CB Setup.

To exit CB Setup but leave the receiver with the CB active, press and release the **MODE SEL** switch or the **COM** pushbutton.

To turn off the CB, press the **COM** button to enter CB Setup. Press soft key **1** to turn the CB ON and Off.

NOTICE

There are no adjustments internal to the CB transceiver chassis that can be performed without risking non-compliance with Federal Communications Commission (FCC) rules. Refer to the original equipment manufacturer for any service required during the warranty period. For transmitter service after the warranty period, refer to a certified repair service. Any frequency determining components, such as crystals, or power determining semi-conductors, etc., should only be replaced with the original component manufacturer's part or equivalent. Substitutes can result in violation of FCC rules. (00175a)

Entering CB Setup

See J in Figure 37. With the CB on, press **COM** to enter CB Setup. The LCD displays CB SETUP in the upper half and the CB channel appears in the lower half.

To exit CB Setup, press and release the **MODE SEL** switch.

After exiting CB Setup with the CB still active, re-enter CB Setup by pressing and releasing the **COM** soft key.

Selecting a Channel

In CB Setup, use the **MODE SEL** switch to select a CB channel. Press and release **MODE SEL UP** or **DN** to switch channels one at a time.

Soft keys 4, 5 and 6 can be used to preset CB channels.

If the **MODE SEL** switch is held up or down, tuning continuously wraps around the ends of the channels.

See K in Figure 37. When squelch is interrupted, the CB in the display inverts. If the squelch is not interrupted and the another source is playing, CB is displayed.

▲ WARNING

Set CB channel, squelch threshold and volume before riding to minimize adjustments on the road. Distractions can lead to loss of control, resulting in death or serious injury. (00089a)

Preset Channels

See J in Figure 37. Up to 3 CB channels can be preset. Press and hold a soft key (4, 5, 6) to preset a CB channel.

Once set, press the preset soft key to switch to the preset channel when the CB display is active.

Adjusting Squelch

See K in Figure 37. The CB signal is passed to the speakers or headsets only if signal strength exceeds the threshold set with the squelch control switch (**PTT/+SQ/-**). When CB signals exceed the threshold, they are said to "break squelch." Refer to Table 26.

- To lower the threshold to process the weakest CB signals, press **SQ -** or rearward.
- To raise the threshold to process stronger signals, press **SQ +** or forward.

In the LCD, a dashed line changes length with the setting.

Table 26. Squelch Control Switch

SQ (-) REARWARD	SQ (+) FORWARD
More signals	Fewer signals
More noise	Less noise
More static	Less static
Unwanted signals	Better sound quality

Transmitting

To transmit, press and hold the **PTT** switch. Transmission is over the CB channel displayed in the LCD. To end transmission, release **PTT**.

Adjusting Volume

Refer to Table 27. See L in Figure 37. To adjust volume of the CB in the speakers or headset, Press **AUDIO +** to raise the volume or **AUDIO -** to lower the volume. CB volume is adjustable when squelch is interrupted or when the display is in CB Setup.

A dashed line that changes length with the volume setting is displayed.

NOTICE

Operating the CB radio without an antenna or with a broken antenna cable can result in damage to the transmitter circuitry. (00176a)

CB Range

Maximum transmission range can only be expected under stable weather conditions in flat, open country.

Weather: In times of atmospheric disturbances, such as rain, snow, or even sunspots, the CB's range can be reduced.

Terrain: Buildings, hills, valleys or any elevated objects or depressions that either block or create a longer path between transmitter and receiver will reduce or disrupt communications.

Obstructions: Transmissions may be cut off under a viaduct or inside a tunnel or parking garage.

NOTE

The CB transmitter is the most powerful allowed under Federal law, but since there is no large steel area to create a ground plane, it may not transmit as strongly as when mounted in a car or truck.

AUTHORIZED
SERVICE

om00518

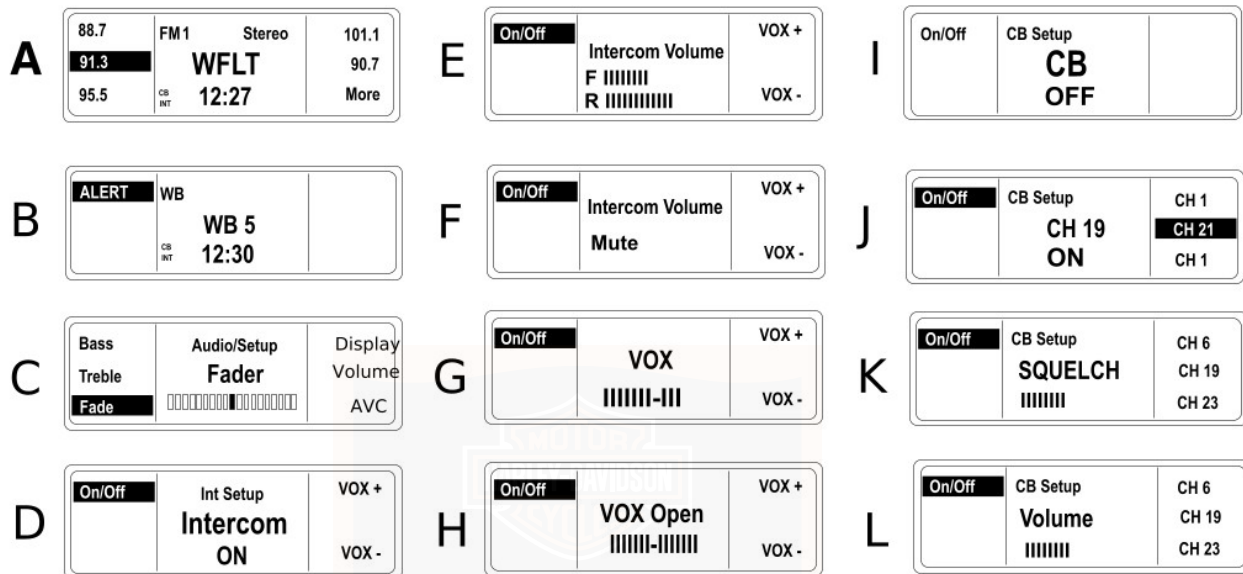

Figure 37. Display Examples

AUDIO ROUTING AND MIXING

General

Refer to Table 27. Whether audio is routed to the headsets, speakers or both depends on the **SPKR** control switch and the **INT** and **CB** buttons on the receiver.

A single audio source routed to headset or speaker can be controlled with the riders **AUDIO** switch or the passenger **VOL** switch.

NOTE

*The passenger volume control switch affects only the passenger headset. The handlebar mounted **AUDIO** switch is the master volume control, and used in conjunction with the fader, affects both the rider and passenger speaker volume.*

Table 27. Audio Routing and Mixing Combinations

AUDIO ROUTING COMBINATIONS			VOLUME CONTROL
SPEAKER CONTROL SWITCH	AUDIO SOURCE(S)	AUDIO OUT	AUDIO ± OR VOL ±
Off or Forward (Headsets)	Music*	Headsets	Music*
	CB	Headsets	CB (During reception or SETUP)
	Intercom	Headsets	Intercom (Only in SETUP)
	Intercom and music*	Both in the headsets	Music
	CB and music*	CB in the headsets (Music is muted during CB reception)	CB (During reception or SETUP)
	Intercom and CB	Both in the headsets (Music is muted during CB reception)	CB (During reception or Setup)

Table 27. Audio Routing and Mixing Combinations

AUDIO ROUTING COMBINATIONS			VOLUME CONTROL
SPEAKER CONTROL SWITCH	AUDIO SOURCE(S)	AUDIO OUT	AUDIO ± OR VOL ±
Center (Speakers and headsets)	Music*	Speakers	Music*
	CB	Headsets	CB (During reception or SETUP)
	Intercom	Headsets	Intercom (Only in SETUP)
	Intercom and music*	Intercom in the headsets Music* in the speakers	Music*
	CB and music*	CB in the headsets Music* in the speakers Music is muted during CB reception	CB
	Intercom and CB	Both in the headsets (Music is MUTED during CB reception)	CB*
On or rearward (Speakers)	Music*	Speakers	Music*
	CB	Speakers	CB (During reception or SETUP)
	Intercom	Headsets	Intercom (Only in SETUP)
	Intercom and music*	Intercom in the headsets. Music in the speakers.	Music
	CB and music*	CB in the speakers (When squelch is broken)	CB
	Intercom and CB	Intercom in the headsets (CB in the speakers MUTED during CB reception)	CB

* Music = Radio, CD player or auxiliary (AUX) audio source.

TROUBLESHOOTING

Operational Troubleshooting

Refer to Table 28. Use the following table to identify rider or passenger control settings that prevent intended operation.

NOTE

See the Electrical Diagnostic Manual for all system diagnosis and electrical troubleshooting information.

NOTICE

There are no serviceable parts inside the unit; leave all servicing to qualified service personnel. Disassembly of the unit could result in equipment damage and/or equipment malfunction. (00172a)

⚠ WARNING

Do not disassemble unit. Laser radiation is present if disc player is disassembled and the interlock fails or is defeated. Exposure to laser radiation could lead to death or serious injury. (00087a)

Radio Fuses

If it is necessary to replace the radio fuses, follow the fuse replacement procedures in this manual or see your Harley-Davidson dealer for service.

See Figure 38. Radio fuses are located in the fuse block under the left side cover.

- A 15 amp radio power fuse allows power to the radio through activation of an internal relay.
- A 15 amp radio memory fuse provides direct and continuous power to the radio memory and time-of-day clock, and when the internal relay is activated, feeds the main circuits of the radio as well.
- A 30 amp fuse provides power to the amplifier mounted under the Tour-Pak.

Remove the radio fuses and inspect the element. Replace the fuse if the element is burned or separated.

NOTE

See Figure 38. Spare 15 and 30 amp fuses are installed in the fuse block.

Table 28. Operational Troubleshooting: Advanced Audio System

THIS	CAN PREVENT THIS
Squelch broken	Fairing music
	Headset music
	Passenger speaker music
Squelch unbroken	CB audio
CB off or low volume	CB audio
Front or rear PTT on	Fairing music
	Headset music
	Passenger speaker music
	CB audio
Handlebar volume low	Fairing music
	Headset music
	Passenger speaker music
Passenger headset volume low	Passenger headset music and CB audio
Fairing SPKR back to speaker	Headset music and headset CB audio
Fairing SPKR forward to headset	Fairing music and CB audio
INT off	Voice communications (Unless PTT is pressed)

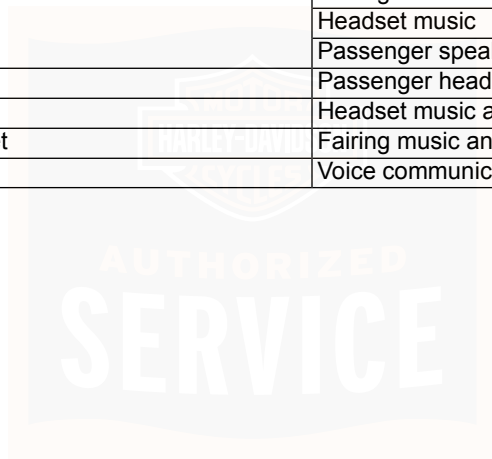

om01156

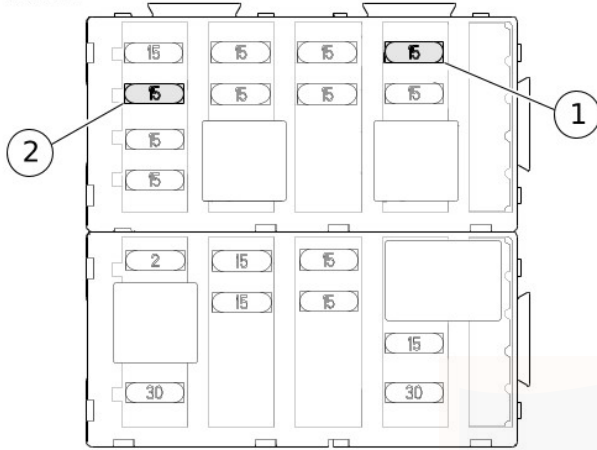

1. Radio power (15 Amp)
2. Radio memory (15 Amp)

Figure 38. Radio Fuses

HARLEY-DAVIDSON SMART SECURITY SYSTEM

Components

See Figure 39. The Harley-Davidson Smart Security System (H-DSSS) consists of a Hands-Free Security Module (HFSM) (1) and a Hands-Free Antenna (2) mounted on the motorcycle, and a Hands-Free Fob **carried** by the rider/passenger.

After parking the motorcycle, turn the ignition key to OFF and the Smart Security System will automatically **arm** within five seconds. While armed, the starter and ignition are disabled and the rider may leave the motorcycle knowing that the module will activate an alarm if someone tampers with the ignition or attempts to move the motorcycle.

If the fob is present, the module will automatically **disarm** when the ignition key is turned to IGNITION or ACCESS.

NOTE

Do not relocate the module or the antenna on the motorcycle.

Options

Several options are available for the Harley-Davidson Smart Security System from the Harley-Davidson Genuine Motor Accessories and Motor Parts catalog. Options include:

- Smart Siren and Smart Siren II.
- Security Pager and Security Pager Receiver II.
- Replacement Fobs.

See a Harley-Davidson dealer for details.

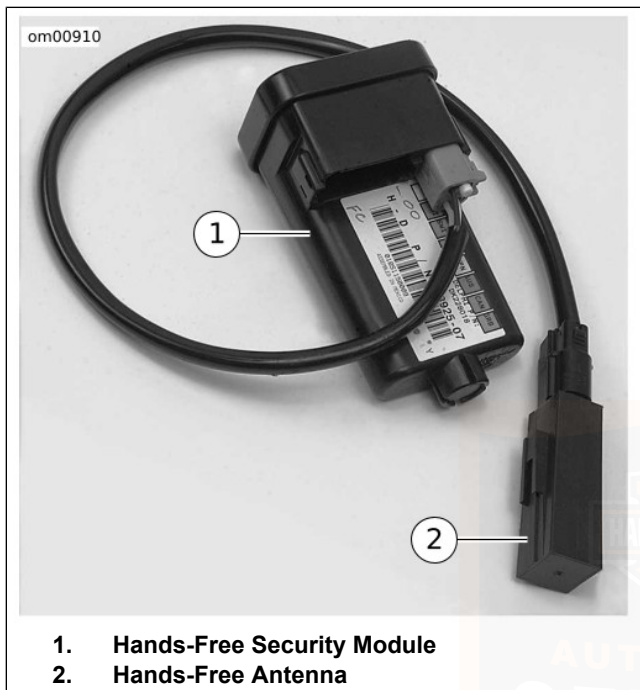

Figure 39. Security Module with Antenna (shown removed)

FCC REGULATIONS

FCC ID: L2C0027TR IC ID: 3432A-0027TR

FCC ID: L2C0028TR IC ID: 3432A-0028TR

This device complies with Part 15 of the FCC Rules and with RSS-210 of Industry Canada rules. Operation is subject to the following two conditions:

(1) This device may not cause harmful interference, and (2) This device must accept any interference received, including interference that may cause undesired operation.

NOTE

Changes or modifications not expressly approved by the party responsible for compliance could void the user's authority to operate the equipment.

The term "IC:" before the radio certification number only signifies that Industry Canada technical specifications were met.

HANDS-FREE FOB

Fob Assignment

See Figure 40. Hands-free fobs are electronically assigned to the Harley-Davidson Smart Security System by a Harley-Davidson dealer so that the module can recognize a fob's unique signal. Only two fobs can be assigned to the module at any one time.

Replacement fobs can be purchased from a dealership but can only be assigned to the motorcycle by a trained Harley-Davidson technician.

NOTE

- *The reusable label found on the fob packaging lists the serial number of the fob. For reference, affix the label to a blank "NOTES" page in this Owner's Manual.*
- *The serial number of the fob is also found on the inside of the fob. See HANDS-FREE SECURITY MODULE > FOB BATTERY (Page 127).*
- *The module will arm only if the fob has been assigned by a Harley-Davidson dealer and a Personal Identification Number (PIN) has been entered in the system. The PIN should be recorded on the Personal Information page in the front of this Owner's Manual and on the removable wallet card.*
- *Should the rider misplace the fob or if the fob fails, the rider can refer to the wallet card and use the PIN to manually disarm the system. Refer to HANDS-FREE SECURITY MODULE > ARMING AND DISARMING (Page 121) and HANDS-FREE SECURITY MODULE > TROUBLESHOOTING (Page 128).*
- *The PIN can easily be changed by the rider at any time. Refer to HANDS-FREE SECURITY MODULE > PERSONAL IDENTIFICATION NUMBER (PIN) (Page 118).*



Figure 40. Hands-Free Fob: Smart Security System

Riding with a Fob

- Always carry the fob when riding, loading, fueling, moving, parking or servicing the motorcycle. Carry the fob in a convenient pocket.

- Do not leave the fob attached to the handlebars or store the fob in a luggage compartment. Unintentionally leaving the fob with the motorcycle when it is parked prevents the system from activating the alarm.
- Do not ride with the fob stored in a metal case or with the fob closer than 76 mm (3.0 in) to a cell phone, PDA, display or other electronic device. Any electromagnetic interference may prevent the fob from disarming the system.
- For added security, always lock the fork and remove the ignition key when parked. If the fob is within range and the motorcycle is unlocked, tampering with the motorcycle will not activate the alarm.

PERSONAL IDENTIFICATION NUMBER (PIN)

The Personal Identification Number (PIN) is a number that can be used to disarm the Harley-Davidson Smart Security System in case an assigned fob is misplaced, fails or if the fob and module cannot communicate because of electromagnetic interference.

A PIN is a five-digit number (1-9, no zeros).

Changing the PIN

To maintain security, the rider can change the PIN at any time. Refer to Table 29.

Table 29. Changing the PIN

STEP NO.	ACTION	WAIT FOR CONFIRMATION	NOTES
1	Select a 5-digit (1 thru 9) PIN and record on the wallet card from Owner's Manual.		
2	With an assigned fob present, turn IGN key IGNITION-OFF-IGNITION-OFF-IGNITION .		
3	Press left turn signal switch 3 times .		
4	Press right turn signal switch 1 time and release.	Turn signals will flash 3 times. Current PIN will appear in odometer. The first digit will be flashing.	See Figure 41.

Table 29. Changing the PIN

STEP NO.	ACTION	WAIT FOR CONFIRMATION	NOTES
5	Enter first digit (a) of new PIN by pressing left turn signal switch a times.		
6	Press right turn signal switch 1 time and release.	The new digit (a) will replace the current in odometer window.	
7	Enter second digit (b) of new PIN by pressing left turn signal switch b times.		
8	Press right turn signal switch 1 time and release.	The new digit (b) will replace the current in odometer window.	
9	Enter third digit (c) of new PIN by pressing left turn signal switch c times.		
10	Press right turn switch 1 time and release.	The new digit (c) will replace the current in odometer window.	
11	Enter fourth digit (d) of new PIN by pressing left turn signal switch d times.		
12	Press right turn switch 1 time and release.	The new digit (d) will replace the current in odometer window.	
13	Enter fifth digit (e) of new PIN by pressing left turn signal switch e times.		

Table 29. Changing the PIN

STEP NO.	ACTION	WAIT FOR CONFIRMATION	NOTES
14	Press right turn switch 1 time and release.	The new digit (e) will replace the current in odometer window.	
15	Before the module rearms, turn the ignition key to OFF .	The odometer will return to mileage.	Turning the ignition key to OFF stores the new PIN in the module.

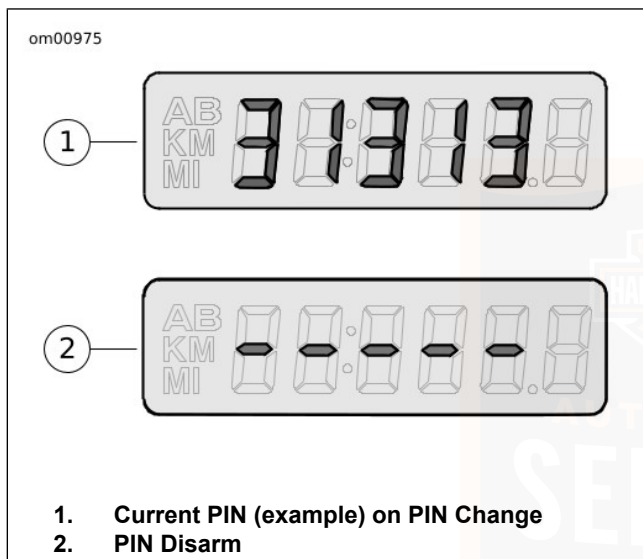

Figure 41. Odometer Windows - PIN

SECURITY STATUS INDICATOR

See Figure 10. The illuminated key icon in the speedometer face indicates the status of the Harley-Davidson Smart Security System.

- **Armed:** A key icon that blinks approximately every 3 seconds indicates that the system is armed.
- **Disarmed:** After the ignition/headlamp switch is turned to IGNITION and the system disarms, the key icon will remain illuminated for approximately four seconds and then turn off.
- **Service:** A key icon that remains illuminated longer than four seconds indicates that service of the module is required.

ARMING AND DISARMING

Arming

When the motorcycle is parked and the ignition key is turned to OFF, the Harley-Davidson Smart Security System arms automatically within five seconds if no motion is detected. Even when the fob is present, the system will arm.

On arming, the turn signals will flash twice and the optional siren will chirp twice. While armed, the key icon in the speedometer face will flash every three seconds.

NOTE

International Models: The HFSM must be in the Chirp Mode for the siren to chirp on arming or on disarming. See *HANDS-FREE SECURITY MODULE > SIREN CHIRP MODE (CONFIRMATION)* (Page 125).

Disarming

Once disarmed, the rider may ride or move the motorcycle for parking, storage or service without setting off the alarm.

Fob: An armed Smart Security System is automatically disarmed when the ignition key is turned to IGNITION with the fob present.

When the module disarms, the optional siren will chirp once and the key icon will illuminate for a solid four seconds and then turn off.

NOTE

Any motion, like lifting the motorcycle up off of its jiffy stand, or turning the ignition key to IGNITION and the module will electronically "poll" for the presence of the fob. If the fob is present, the system disarms.

Personal Identification Number (PIN): If the fob is misplaced or if the present fob fails to communicate with the module, the system can be disarmed with the Personal Identification Number (PIN).

Disarming with a PIN

Do not turn handlebars, straddle seat or lift motorcycle off the jiffy stand. During a PIN disarm, if the Smart Security System detects motorcycle motion the system will activate the alarm.

Table 30. Entering a PIN to Disarm Harley-Davidson Smart Security System

STEP NO.	ACTION	WAIT FOR CONFIRMATION	NOTES
1	If necessary, verify the current 5-digit PIN.		Should be recorded on wallet card.
2	Turn ignition key to IGNITION .		
3	Quickly (within 2 seconds of turning ignition key) hold both turn signal switches in until confirmation.	Key icon flashes at fast rate. In the odometer window, a flashing dash will be followed by four more dashes.	See Figure 41. Five dashes will appear in the odometer window.
4	Enter first digit (a) in the PIN by pressing left turn switch a times .	The first digit (a) in the odometer will be the first digit in the PIN.	
5	Press right turn switch 1 time .	The first digit is stored and the dash will flash.	Serves as enter key.
6	Enter second digit (b) in the PIN by pressing left turn switch b times .	The second digit (b) in the odometer will be the second digit in the PIN.	
7	Press right turn switch 1 time .	The second digit is stored and the next dash will flash.	Serves as enter key.
8	Enter third digit (c) in the PIN by pressing left turn switch c times .	The third digit (c) in the odometer will be the third digit in the PIN.	
9	Press right turn switch 1 time .	The third digit is stored and the next dash will flash.	Serves as enter key.
10	Enter fourth digit (d) in the PIN by pressing left turn switch d times .	The fourth digit (d) in the odometer will be the fourth digit in the PIN.	
11	Press right turn switch 1 time .	The fourth digit is stored and the next dash will flash.	Serves as enter key.

Table 30. Entering a PIN to Disarm Harley-Davidson Smart Security System

STEP NO.	ACTION	WAIT FOR CONFIRMATION	NOTES
12	Enter fifth digit (e) in the PIN by pressing left turn switch e times .	The fifth digit (e) in the odometer will be the fifth digit in the PIN.	
13	Press right turn switch 1 time .	The fifth digit is stored. The key icon stops blinking.	Smart Security System is disarmed.

NOTE

- *At any time during a PIN disarm, if the fob is brought within range of the motorcycle, the Smart Security System will disarm when the module receives the coded signal from the fob.*
- *If a mistake is made while entering PIN, wait two minutes before another disarming attempt.*
- *The Smart Security System will remain disarmed until the ignition key is turned to OFF.*

Arming with Hazard Warning 4-Way Flashers On

If it should be necessary to leave a motorcycle parked along side a roadway, the hazard warning four-way flashers can be turned ON and the Smart Security System armed.

1. Turn ignition key to IGNITION.

2. Simultaneously press both left and right turn signal switches to turn the four-way flashers ON.
3. Turn the ignition key to OFF to arm the Smart Security System.

To turn hazard warning flashers OFF, turn the ignition key to IGNITION and simultaneously press the left and right turn signal switches.

ALARM

Warnings

Once armed, if the motorcycle is moved or lifted up off of its jiffy stand or if the ignition key is turned to IGNITION and the fob is not present, the alarm will warn the operator with three alternate flashes of the turn signals and a chirp of the optional siren.

Within four seconds, if the motorcycle is back on its jiffy stand and no further motion is detected and/or the ignition key is

turned to OFF, the module will remain armed without activating the alarm.

If the motorcycle motion continues or the ignition key is not turned back to OFF, the module will issue a second warning four seconds after the first.

NOTE

During warnings and alarms, the starter motor and the ignition circuits are disabled.

The Alarm

If the Smart Security System is still detecting motion and/or if the ignition key has not been turned back to OFF after a second warning, the system will activate the alarm.

When activated, the Smart Security System will:

- Alternately flash the four turn signals.
- See Figure 42. Sound the optional siren.

Duration: The alarm will stop within 30 seconds and if no motion is detected, the alarm will not restart.

However, if motorcycle motion continues the system will repeat the 30 second alarm and recheck for motion. The alarm will repeat this 30 second alarm cycle for five minutes (10 cycles) or until the alarm is deactivated.

NOTE

The alarm will also activate the LED, vibration or audible modes of a Harley-Davidson Security Pager. A pager can operate either in silent or in combination with an optional Smart Siren. The range of a pager can be up to 0.8 km (0.5 mi). See a Harley-Davidson dealer for details.

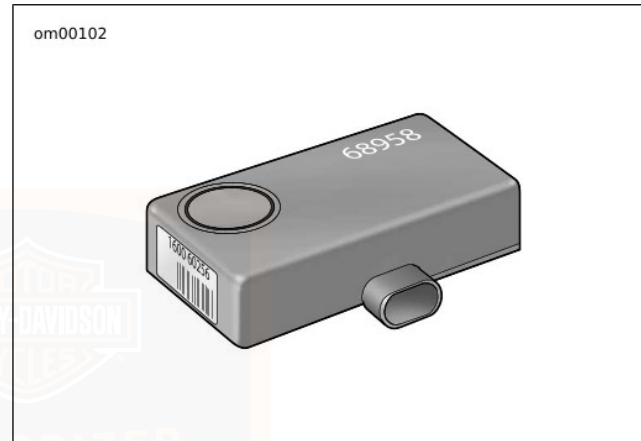

Figure 42. Optional Smart Siren

Deactivate the Alarm

Key Fob: Bring the fob to the motorcycle. After the module identifies that the fob is present, the system will terminate the alarm.

SIREN CHIRP MODE (CONFIRMATION)

Chirpless Mode

In the chirpless mode, the siren does not chirp on arming or disarming.

NOTE

Even when armed in the chirpless mode, the siren still chirps warnings on movement and will activate the alarm through cycles.

Chirp Mode

On arming in the chirp mode, the siren responds with two chirps. When disarming, the siren responds with a single chirp.

Switching Modes

Cycling quickly through two armings and disarmings will switch the system from either the chirpless mode or the chirp mode to its opposite.

1. With the fob present, the ignition switch to ON and the system disarmed, turn the ignition switch OFF.
2. When the system arms (two flashes of turn signals), immediately turn the ignition switch to ON.
3. Wait until the security lamp goes out, then immediately turn the ignition switch OFF.
4. When the system arms (two flashes of turn signals), immediately turn the ignition switch to ON and wait for system to disarm.

TRANSPORT MODE

It is possible to arm the security system without enabling the motion detector for one ignition cycle. This allows the vehicle to be picked up and moved in an armed state, however, any attempt to start the engine when the key fob is not within range will trigger the alarm.

To Enter Transport Mode

1. Turn the ignition switch to IGNITION.
2. Set the engine stop switch to OFF.
3. With an assigned fob within range, turn the ignition switch from IGNITION to ACC.
4. Simultaneously press both the left and the right turn signal switches. This must be done within five seconds of turning the ignition switch to ACC.

5. After the turn signals flash once, turn the ignition switch to OFF and the module is armed.
6. Confirmation: Turn signal blinks three times when armed for one ignition cycle.

To Exit Transport Mode

Return the system to normal operation:

With the fob present, turn the ignition switch to IGNITION to disarm the HFSM. To cancel the transport mode, set the engine stop switch to RUN.

STORAGE AND SERVICE DEPARTMENTS

Long-Term Parking

To maintain arming, store the fob beyond the range of the module. If the motorcycle is to be moved while parked, have the fob present.

If the motorcycle will not be operated for several months, such as during the winter season, refer to MAINTENANCE AND LUBRICATION > MOTORCYCLE STORAGE (Page 196).

Service Departments

When the motorcycle is to be left at a Harley-Davidson dealer, there are two options:

1. Leave an assigned fob with the dealer.
2. To maintain possession of the fob, ask the dealer to disable the module for service (service mode) before leaving the dealership.

SIDECAR CONFIGURATION

⚠ WARNING

Only Touring Harley-Davidson Motorcycles are suitable for sidecar use. Consult a Harley-Davidson dealer. Use of motorcycles other than Touring models with sidecars could result in death or serious injury. (00040a)

NOTICE

Before operating your motorcycle with sidecar attached, have a Harley-Davidson dealer install a Bank Angle Switch kit. The TSM/HFSM will not function properly if not switched to sidecar operation. (00486c)

On motorcycles with a sidecar, the turn signal module (TSM) or the Hands-Free Security Module (HFSM) must be switched from the factory solo vehicle setting to the sidecar setting. Consult a Harley-Davidson dealer for complete details.

If a sidecar is permanently removed from the motorcycle, the TSM or the HFSM must be reconfigured. Refer to the SIDECAR SERVICE MANUAL for complete details.

FOB BATTERY

Replacing the Battery

Replace the key fob battery every year.

1. See Figure 43. Slowly turn a thin blade in the thumbnail slot (1) on the side of the fob to separate the two halves.
2. Remove the battery (2) and discard.

NOTE

Dispose of the old battery in accordance with local regulations.

3. Install a **new** battery (Panasonic 2032 or equivalent) with the positive (+) side down.
4. Align the two halves of the fob and snap together.

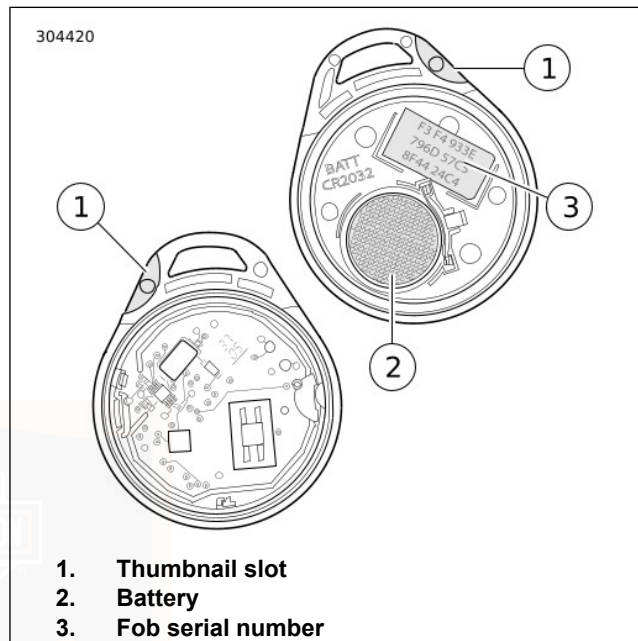

Figure 43. Hands-Free Fob Battery

DISCONNECTING POWER

Optional Siren

When disconnecting the battery or removing the main fuse, perform the following steps to prevent the optional siren from sounding.

1. Verify that the fob is present.
2. Turn the ignition key to IGNITION.
3. Pull the main fuse from its holder or disconnect the battery.

TROUBLESHOOTING

Key Icon

If the system key icon stays illuminated while riding, see a Harley-Davidson dealer.

Fob

If the Smart Security System continues to actuate warnings and alarms with the fob present, one of the following can be the cause:

1. **Electromagnetic Interference:** Other electronic devices, power lines, or other electromagnetic sources can cause the Smart Security System to operate inconsistently.
 - a. Verify that the fob is not in a metal enclosure or within 76 mm (3.0 in) of any other electronic devices.
 - b. Place the fob on the seat and turn the ignition key to IGNITION. After the module disarms, return the fob to a convenient location.
 - c. Move motorcycle at least 5 m (15 ft) from the spot of interference.
2. **Discharged Fob Battery:** Use the PIN to disarm the module. Replace the battery. Refer to HANDS-FREE SECURITY MODULE > FOB BATTERY (Page 127).
3. **A Damaged Fob:** Use the PIN to disarm the motorcycle. Replacement fobs are available for purchase from a Harley-Davidson dealer.

Siren

- If the siren does not chirp two or three times on a valid arming command from the security module, the siren is either in the Chirpless Mode, not connected, not working, or the siren wiring was opened or shorted while the siren was disarmed.

- If the siren is armed and the internal siren battery is dead, shorted, disconnected, or has been charging for a period longer than 24 hours, the siren will respond with three chirps on arming instead of two.
- The internal siren battery may not charge if the vehicle's battery is less than 12.5 volts.
- If the siren enters the self-driven mode where it is powered from the siren's internal 9 volt battery, the turn signal lamps may or may not alternately flash. If the security module activates the siren, the turn signal lamps will alternately flash. If the siren has been armed and a security event occurs, and the siren is in self-driven mode, the siren will alarm for 20 to 30 seconds and then turn off for 5 to 10 seconds. This alarm cycle will be repeated ten times if the siren is in the self-driven mode.



NOTES



OPERATING RECOMMENDATIONS

⚠ WARNING

Motorcycles are different from other vehicles. They operate, steer, handle and brake differently. Unskilled or improper use could result in loss of control, death or serious injury.

- Take a rider training course.
- Read owner's manual before riding, adding accessories or servicing.
- Wear a helmet, eye protection and protective clothing.
- Never tow a trailer.

(00556d)

- Take a rider training course.
- Read Owner's Manual before riding, adding accessories or servicing.
- Wear a helmet, eye protection and protective clothing.
- Never tow a trailer.

NOTICE

Do not run the engine at extremely high RPM with clutch disengaged or transmission in neutral. Running an engine at high RPM can result in engine damage. (00177a)

NOTICE

Do not exceed the maximum safe RPM specified below under any conditions. Exceeding the maximum safe engine RPM can result in equipment damage. (00248a)

- The maximum recommended safe engine speed is 5500 RPM.
- Do not idle engine unnecessarily for more than a few minutes with motorcycle standing still.

NOTICE

Air-cooled engines require air movement over the cylinders and heads to maintain proper operating temperature. Extended periods of idling or parade duty can overheat the engine, resulting in serious engine damage. (00178a)

An engine running long distances at high speed must be given closer than ordinary attention to avoid overheating and possible engine damage.

This applies particularly to a motorcycle equipped with windshield and fairing.

NOTE

Have the engine checked regularly and keep it well tuned.

▲ WARNING

When riding on wet roads, brake efficiency and traction are greatly reduced. Failure to use care when braking, accelerating or turning on wet roads can cause loss of control, which could result in death or serious injury. (00041a)

NOTE

When descending upon a long, steep grade, downshift and use engine compression together with intermittent application of both brakes to slow the motorcycle.

▲ WARNING

Continuous use of brake causes overheating and reduced efficiency, which could result in death or serious injury. (00042a)

▲ WARNING

Do not tow a disabled motorcycle. Towing can adversely affect stability and handling, which could result in death or serious injury. (00017a)

BREAK-IN RIDING RULES

The First 500 Miles (800 Kilometers)

The sound design, quality materials, and workmanship that are built into your new Harley-Davidson will give you optimum performance right from the start.

To allow your engine to wear-in its critical parts, we recommend that you observe the riding rules provided below for the first 800 km (500 mi).

1. During the first 80 km (50 mi) of riding, keep the engine speed below 3000 RPM in any gear. Do not lug the engine by running or accelerating at very low RPM, or by running at high RPM longer than needed for shifting or passing.

NOTE

For models without a tachometer, operate the motorcycle according to the speeds given in Table 31 and Table 32 during motorcycle break-in.

2. Up to 800 km (500 mi), vary the engine speed and avoid operating at any steady engine speed for long periods. Engine speed up to 3500 RPM in any gear is permissible.
3. Drive slowly and avoid fast starts at wide open throttle until the engine has warmed up.

4. Avoid lugging the engine by not running the engine at very low speeds in higher gears.
5. Avoid hard braking. Break-in new brakes with moderate use for the first 300 km (200 mi).

PRE-RIDING CHECKLIST

⚠ WARNING

Identify and understand the specific features of your vehicle. Failure to understand how these features affect the vehicle's operation can lead to an accident, which could result in death or serious injury. (00043b)

Before riding your motorcycle at any time, make a general inspection to be sure it is in safe riding condition.

⚠ WARNING

Stop the engine when refueling or servicing the fuel system. Do not smoke or allow open flame or sparks near gasoline. Gasoline is extremely flammable and highly explosive, which could result in death or serious injury. (00002a)

⚠ WARNING

Avoid spills. Slowly open fuel filler cap. Do not fill above bottom of filler neck insert, leaving air space for fuel expansion. Secure filler cap after refueling. Gasoline is extremely flammable and highly explosive, which could result in death or serious injury. (00028b)

⚠ WARNING

Use care when refueling. Pressurized air in fuel tank can force gasoline to escape through filler tube. Gasoline is extremely flammable and highly explosive, which could result in death or serious injury. (00029a)

1. Verify fuel is present in tank and add fuel if required.
2. Adjust mirrors to proper riding positions.
3. Check the oil level. Add oil if necessary.
4. Check controls to make sure they operate properly. Operate the front and rear brakes, throttle, clutch and shifter. All controls should operate freely without binding.
5. Check steering for proper operation by turning the handlebars through the full operating range. Handlebars should turn smoothly without binding.

▲ WARNING

Be sure tires are properly inflated, balanced, undamaged, and have adequate tread. Inspect your tires regularly and see a Harley-Davidson dealer for replacements. Riding with excessively worn, unbalanced, improperly inflated, overloaded or damaged tires can lead to tire failure and adversely affect stability and handling, which could result in death or serious injury. (00014b)

6. Check tire condition and pressure. Incorrect pressure will result in poor riding characteristics and can affect handling and stability. Refer to tire specifications for correct inflation pressure to use.

▲ WARNING

Be sure headlamp, tail and stop lamp and turn signals are operating properly before riding. Poor visibility of rider to other motorists can result in death or serious injury. (00478b)

7. Check all electrical equipment and switches including the headlamp, stop lamp, turn signals and horn for proper operation.
8. Check for any fuel, oil or hydraulic fluid leaks.

9. Check drive belt for wear or damage.
10. Service your motorcycle as necessary.

STARTING THE ENGINE

General

NOTICE

The engine should be allowed to run slowly for 15-30 seconds. This will allow the engine to warm up and let oil reach all surfaces needing lubrication. Failure to comply can result in engine damage. (00563b)

Do not roll the throttle before starting. Rolling the throttle before starting the motorcycle is unnecessary.

Starting

▲ WARNING

Shift transmission to neutral before starting engine to prevent accidental movement, which could result in death or serious injury. (00044a)

1. Turn ignition/headlamp key switch to IGNITION position. Do not roll the throttle.

2. See Figure 44. Turn the off/run switch to RUN position.

NOTE

The engine lamp will light for approximately 4 seconds and you will hear the fuel pump purr for approximately 2 seconds as it operates to fill the fuel lines with gasoline.

3. Squeeze the clutch lever in against the handgrip.

NOTE

To activate the starting system, the clutch interlock circuitry requires the clutch be disengaged, clutch lever pulled in against left handgrip, and/or the transmission be shifted to the neutral position (green neutral lamp lit).

4. Raise the jiffy stand (required on international models).
5. Press the starter button to start the motorcycle.
6. When the engine has started, you can operate your motorcycle as you normally would after raising the jiffy stand.

NOTE

- *If the fuel tank becomes completely dry, it may take a few seconds longer to start the motorcycle after filling the tank. It will not be necessary to take any extraordinary measures before starting the motorcycle.*
- *The ABS indicator lamp will remain on until vehicle is moving approximately 5 km/h (3 mph).*

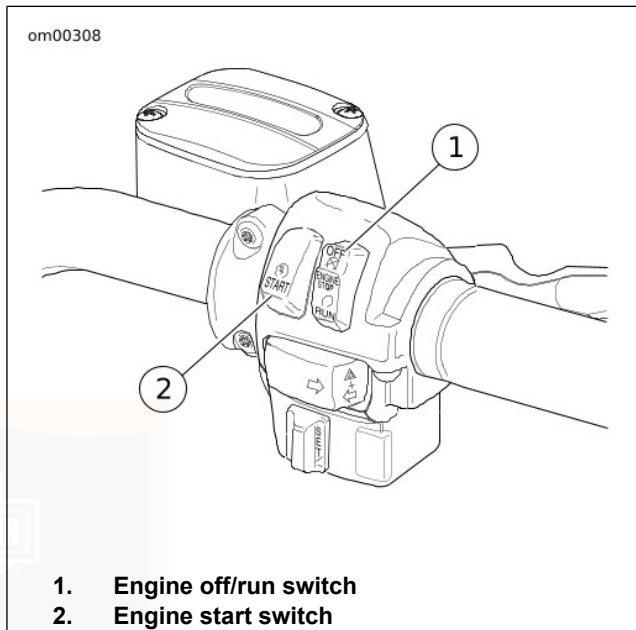

Figure 44. Right Handlebar Controls: Touring Models (typical)

AUTOMATIC COMPRESSION RELEASE (ACR)

Vehicles with Twin Cam 103 and 110 engines are equipped with an Automatic Compression Release (ACR). During

starting, a small auxiliary valve in the cylinder head is opened automatically by the ECM. The open valve releases the air compressed in the cylinder heads and allows the starter motor to turn the high compression engine over at a faster rate to aid starting.

After starting and during normal operation, the ACR valves remain closed.

ENGINE IDLE TEMPERATURE MANAGEMENT SYSTEM

For those riders who frequently find themselves in riding conditions where the vehicle is subjected to prolonged idle conditions or traffic congestion, the motorcycle is equipped with an Engine Idle Temperature Management System (EITMS) to provide limited cooling of the rear cylinder.

Operation

When engine temperature reaches a pre-determined point, the EITMS will turn off the rear cylinder fuel injector. Idle speed will be maintained, however the rear cylinder will become an "air pump" which will work to cool the engine.

EITMS will activate (rear cylinder will turn off) when **all** of the following conditions are met:

- Engine temperature is greater than 165 °C (287 °F)
- Twist grip opening is at idle

136 Operation

- Vehicle speed under 2 km/h (1 mph)
- Engine speed under 1200 RPM

EITMS will disable (rear cylinder will again fire) if **any one** of the following occurs:

- Engine temperature falls below 135 °C (275 °F)
- Twist grip opening is greater than idle
- Vehicle speed exceeds 3 km/h (2 mph)
- Engine speed exceeds 1350 RPM
- Clutch is released with vehicle in gear

When the engine is in EITMS operation, you may notice a difference in idle cadence. Additionally, there may be a unique exhaust odor. These are both considered to be normal conditions.

Enabling/Disabling EITMS

Enabled: The EITMS engine cooling feature will automatically activate whenever the vehicle comes to a complete stop and is idling during elevated temperature conditions. Even with the feature enabled, it may not activate under cool riding conditions.

Disabled: The EITMS feature is not active under any conditions.

Vehicles are delivered from the factory with EITMS disabled. EITMS can be enabled or disabled by the rider by performing the following procedure.

1. Turn the ignition switch to the ON position and push the engine OFF/RUN switch on the right handlebar to the RUN position (do not start the motorcycle).
2. Push the throttle to roll-off position and hold.
3. See Figure 10. After approximately 3 seconds, the cruise indicator lamp will either flash green (EITMS enabled) or red (EITMS disabled).

NOTE

A flashing lamp indicates the EITMS setting. A solid (non-flashing) lamp indicates the cruise control setting.

4. Repeat the procedure as needed to enable or disable EITMS.

NOTE

The EITMS setting will remain in effect until it is changed by the rider or dealer. It does not have to be reconfigured at each startup.

STOPPING THE ENGINE

1. Stop the engine by turning OFF the engine stop switch on right handlebar.

2. Turn OFF the ignition/headlamp key switch. If the engine should be stalled or stopped in any way, turn off the ignition/headlamp key switch at once to prevent battery discharge.

SHIFTING GEARS

Getting Started

NOTE

Always start engine with transmission in neutral. Always start motorcycle forward motion from first gear.

NOTICE

The clutch must be fully disengaged before attempting a gear shift. Failure to fully disengage the clutch can result in equipment damage. (00182a)

The shift pattern is first gear down, next five gears up.

1. With motorcycle engine running and jiffy stand retracted, pull the clutch hand lever in against handlebar grip to fully disengage clutch.
2. Press the foot shift lever down to end of its travel and release. The transmission is now in first gear.
3. To start forward motion, ease out the clutch lever slowly and at the same time, open throttle gradually.

Upshift (Acceleration)

Refer to Table 31. Engage second gear after the motorcycle has reached at the appropriate shifting speed.

Table 31. Upshift (Acceleration) Gear Speeds: Six Speed

GEAR CHANGE	MPH	KPH
First to second	15	25
Second to third	25	40
Third to fourth	35	55
Fourth to fifth	45	70
Fifth to sixth	55	85

1. Close the throttle.
2. Disengage the clutch (pull clutch lever in).
3. See Figure 45. Lift the gear shift lever up to the end of its travel and release.
4. Ease out the clutch lever and gradually open the throttle.
5. Repeat the previous steps to engage third, fourth, fifth, and sixth gears.

NOTE

- *Disengage the clutch completely before each gear change.*
- *Partially close the throttle so the engine will not drag when clutch is again engaged (clutch lever released).*

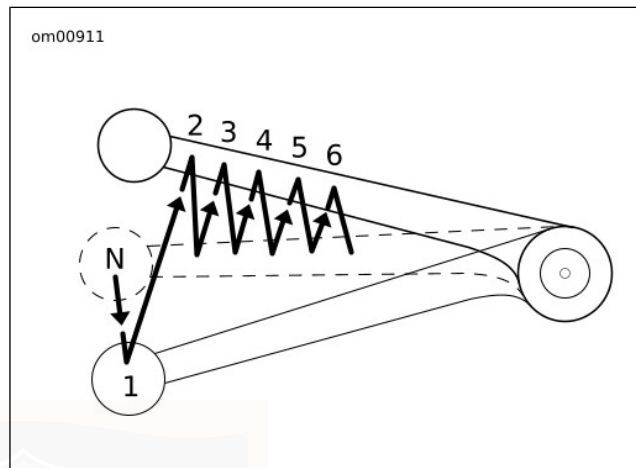

Figure 45. Shifting Sequence: Upshift

Downshift (Deceleration)

⚠ WARNING

Do not downshift at speeds higher than those listed. Shifting to lower gears when speed is too high can cause the rear wheel to lose traction and lead to loss of vehicle control, which could result in death or serious injury. (00045b)

Gear shift pattern is first gear down; next five gears up. Refer to Table 32 for shifting speeds.

Table 32. Downshift (Deceleration) Gear Speeds: Six Speed

GEAR CHANGE	MPH	KPH
Sixth to fifth	50	80
Fifth to fourth	40	65
Fourth to third	30	50
Third to second	20	30
Second to first	10	15

NOTE

The shifting points shown in the tables are recommendations. Vehicle owners may determine that their own individual shifting patterns may differ than those stated and are additionally appropriate for individual riding styles.

See Figure 46. When engine speed decreases, as in climbing a hill or running at a reduced speed, shift to the next lower gear while partially closing the throttle so the engine accelerates as soon as the clutch lever is released.

NOTE

- Disengage the clutch completely before each gear change.
- Partially close the throttle so the engine will not drag when clutch is again engaged (clutch lever released).

NOTICE

Shift to neutral before stopping engine. Shifting mechanism can be damaged by shifting gears while engine is stopped. (00183a)

The gear shifter mechanism permits shifting the transmission to neutral from either first or second gear.

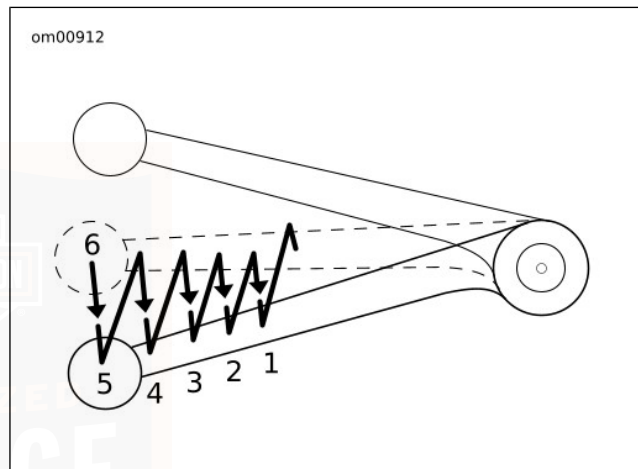

Figure 46. Shifting Sequence: Downshift

NOTES



SAFE OPERATING MAINTENANCE

▲ WARNING

Perform the service and maintenance operations as indicated in the regular service interval table. Lack of regular maintenance at the recommended intervals can affect the safe operation of your motorcycle, which could result in death or serious injury. (00010a)

NOTICE

When lifting a motorcycle using a jack, be sure jack contacts both lower frame tubes where down tubes and lower frame tubes converge. Never lift by jacking on cross-members, oil pan, mounting brackets, components or housings. Failure to comply can cause serious damage resulting in the need to perform major repair work. (00586d)

Good maintenance creates a safe motorcycle. A careful check of certain equipment must be made after periods of storage. Also, frequently inspect the motorcycle between the regular service intervals to determine if additional maintenance is necessary.

Check the following items:

1. Tires for correct pressure, abrasions or cuts.

2. Belt and primary chain for proper tension, wear or damage.
3. Brakes, steering and throttle for responsiveness and freedom from binding.
4. Brake fluid level and condition. Hydraulic lines and fittings for leaks. Also, check brake pads and discs for wear.
5. Cables for fraying or crimping and free operation.
6. Engine oil and primary chaincase/transmission fluid levels.
7. Headlamp, tail lamp, brake lamp and turn signals for proper operation.

BREAK-IN MAINTENANCE

NOTE

The performance of new motorcycle initial service is required to keep your new motorcycle warranty in force and for proper emissions system operation.

Refer to Table 44. After a new motorcycle has been ridden its first 1,600 km (1000 mi), it should be taken to an authorized Harley-Davidson dealer for initial service operations.

ENGINE LUBRICATION

NOTICE

Do not switch lubricant brands indiscriminately because some lubricants interact chemically when mixed. Use of inferior lubricants can damage the engine. (00184a)

Engine oil is a major factor in the performance and service life of the engine. Always use the proper grade of oil for the lowest temperature expected before the next scheduled oil

change. Refer to Table 33. Your authorized dealer has the proper oil to suit your requirements.

If it is necessary to add oil and Harley-Davidson oil is not available, use an oil certified for diesel engines. Acceptable diesel engine oil designations include: CF-4, CG-4, CH-4 and CI-4.

The preferred viscosities for the diesel engine oils in descending order are: 20W50, 15W40 and 10W40.

At the first opportunity, see an authorized dealer to change back to 100 percent Harley-Davidson oil.

Table 33. Recommended Engine Oils

H-D TYPE	VISCOSITY	H-D RATING	LOWEST AMBIENT TEMPERATURE	COLD WEATHER STARTS BELOW 50 °F (10 °C)
H-D Multi-grade	SAE 10W40	HD 360	Below 4 °C (40 °F)	Excellent
Screamin' Eagle SYN3 Synthetic Motorcycle Lubricant	SAE 20W50	HD 360	Above 4 °C (40 °F)	Excellent
H-D Multi-grade	SAE 20W50	HD 360	Above 4 °C (40 °F)	Good
H-D Regular Heavy	SAE 50	HD 360	Above 16 °C (60 °F)	Poor
H-D Extra Heavy	SAE 60	HD 360	Above 27 °C (80 °F)	Poor

CHECKING OIL LEVEL

Check engine oil level at each complete fuel refill.

NOTICE

Do not allow hot oil level to fall below Add/Fill mark on dipstick. Doing so can result in equipment damage and/or equipment malfunction. (00189a)

NOTICE

Oil level cannot be accurately measured on a cold engine. For pre-ride inspection, with motorcycle leaning on jiffy stand on level ground, oil should register on dipstick between arrows when engine is cold. Do not add oil to bring the level to the FULL mark on a COLD engine. (00185a)

NOTICE

Do not overfill oil. Doing so can result in oil carryover to the air cleaner leading to equipment damage and/or equipment malfunction. (00190b)

Oil Level Cold Check

1. For pre-ride inspection, place vehicle on level ground and rest the vehicle on its jiffy stand (unless sidecar is attached).
2. See Figure 47. Remove filler plug/dipstick and wipe off the dipstick. Insert the dipstick and tighten into the fill spout.

NOTE

The oil level marks for checking with motorcycle upright or on jiffy stand are on the same side of the dipstick. Be sure to use the correct portion of dipstick when checking oil level.

3. See Figure 48. Remove the dipstick and verify the level of the oil. The correct oil level should register midway (2) between the FULL and ADD marks on the dipstick.

NOTE

If oil level is at or below the ADD mark, add only enough oil to bring the level to the middle of the two marks on the dipstick.

Oil Level Hot Check

NOTE

- *The engine will require a longer warm up period in colder weather.*
 - *Engine oil level hot check should be performed only when engine is at normal operating temperature.*
1. Ride motorcycle until engine is at normal operating temperature.
 2. Place vehicle on level ground and rest the vehicle on its jiffy stand (unless sidecar is attached). Allow engine to idle for 1-2 minutes. Turn engine off.

3. See Figure 47. Remove filler plug/dipstick and wipe off the dipstick. Insert the dipstick and tighten into the fill spout.

NOTE

The oil level marks for checking with motorcycle upright or on jiffy stand are on the same side of the dipstick. Be sure to use the correct portion of dipstick when checking oil level.

4. See Figure 48. Remove the dipstick and note the level of the oil. The level should be between the ADD (1) and FULL (3) marks. Add oil as necessary to bring the level to the FULL mark on the dipstick. Do not overfill.

NOTE

Refer to Table 33. Use only recommended oil specified in MAINTENANCE AND LUBRICATION > ENGINE LUBRICATION (Page 142).

5. Start engine and carefully check for oil leaks around drain plug and oil filter.

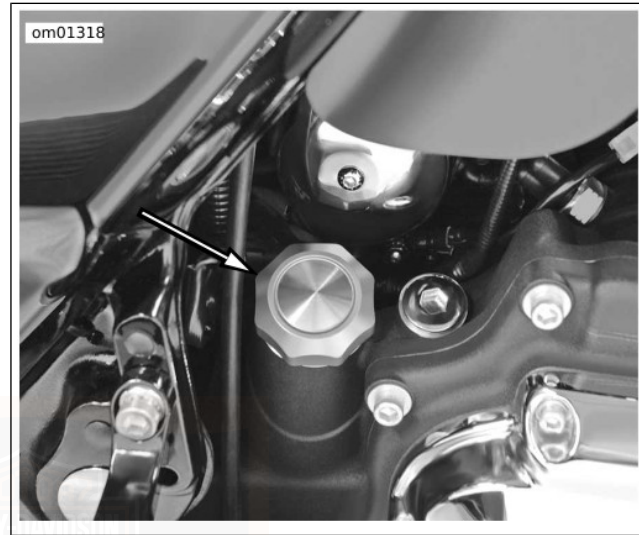

Figure 47. Engine Oil Filler Cap

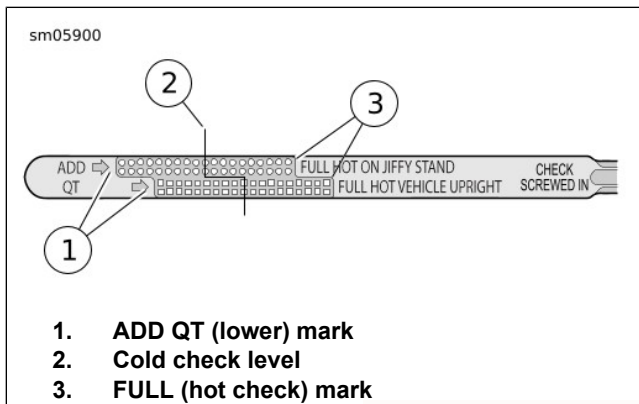

Figure 48. Engine Oil Dipstick

CHANGING OIL AND OIL FILTER

Refer to Table 44. Oil should be changed after the first 1,600 km (1000 mi) for a new engine and at regular intervals in normal service at warm or moderate temperatures.

Oil change intervals should be more frequent in cold weather or severe operating conditions. See **MAINTENANCE AND LUBRICATION > WINTER LUBRICATION** (Page 147).

Twin Cam equipped vehicles require the premium oil filter (Part No. 63798-99A Chrome or Part No. 63731-99A Black).

NOTICE

Do not switch lubricant brands indiscriminately because some lubricants interact chemically when mixed. Use of inferior lubricants can damage the engine. (00184a)

⚠ WARNING

Be sure that no lubricants or fluids get on tires, wheels or brakes when changing fluid. Traction can be adversely affected, which could result in loss of control of the motorcycle and death or serious injury. (00047d)

1. Ride motorcycle until oil is at normal operating temperature. Turn engine off.
2. Remove filler plug/dipstick.
3. See Figure 49. Remove the oil drain plug (2). Do not remove hex plug (3) or transmission drain plug (1). Allow oil to drain completely.
4. Inspect the oil drain plug O-ring for cuts, tears or signs of deterioration. Replace as necessary.

NOTICE

Use Harley-Davidson oil filter wrench for filter removal. This tool can prevent damage to crankshaft position sensor and/or sensor cable. (00192b)

5. Remove the oil filter using OIL FILTER WRENCH (PART NUMBER: HD-42311) or OIL FILTER WRENCH (PART NUMBER: HD-44067-A) and hand tools. Do not use with air tools.
6. Clean the oil filter mount flange of any old gasket material.

NOTE

Dispose of oil and oil filter in accordance with local regulations.

7. See Figure 50. Lubricate gasket with clean engine oil and install **new** oil filter on filter mount. Hand-tighten oil filter one-half to three-quarters of a turn after gasket first contacts filter mounting surface. Do NOT use oil filter wrench for installation.
8. Install engine oil drain plug and tighten to 19–28.5 N·m (14–21 ft-lbs).

NOTE

Use the proper grade of oil for the lowest temperature expected before the next oil change. Refer to Table 33 for recommended oil.

9. Initially add 3.3 L (3.5 qt) of engine oil.

10. Verify proper oil level. See MAINTENANCE AND LUBRICATION > CHECKING OIL LEVEL (Page 142).
 - a. Check engine oil level using **COLD CHECK** procedure.
 - b. Start engine and carefully check for oil leaks around drain plug and oil filter.
 - c. Check engine oil level using **HOT CHECK** procedure.

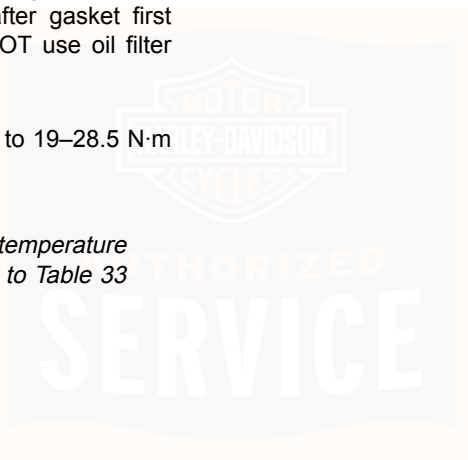

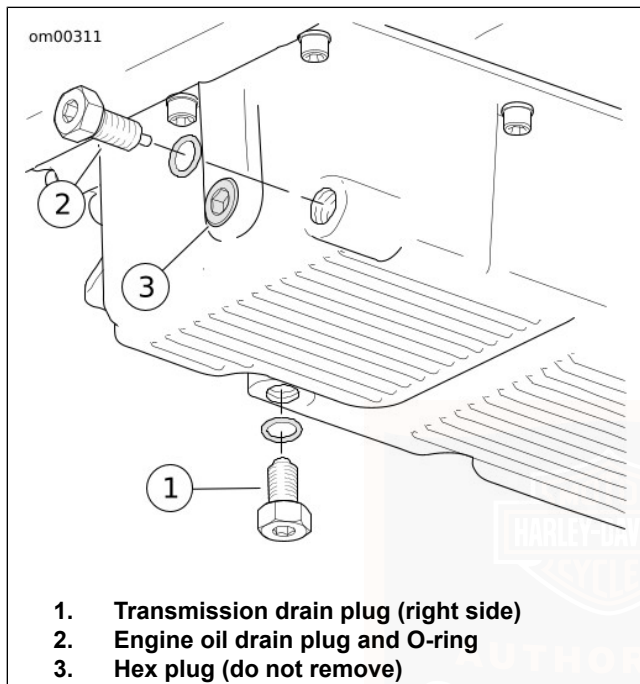

Figure 49. Oil Pan

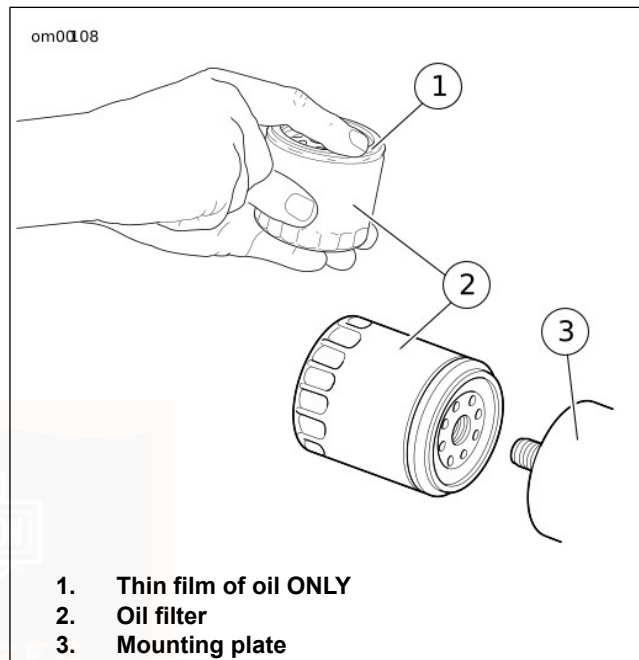

Figure 50. Applying Thin Oil Film

WINTER LUBRICATION

In colder climates, the engine oil should be changed often. If motorcycle is used frequently for short trips, less than 24 km (15 mi), in ambient temperatures below 16 °C (60 °F), oil

change intervals should be reduced to 2,400 km (1500 mi). Motorcycles used only for short runs must have a thorough tank flush-out before **new** oil is put in. The tank flush-out should be performed by an authorized dealer or qualified technician.

NOTE

The further below freezing the temperature drops, the shorter the oil change interval should be.

Water vapor is a normal by-product of combustion in any engine. During cold weather operation, some of the water vapor condenses to liquid form on the cool metal surfaces inside the engine. In freezing weather this water will become slush or ice and, if allowed to accumulate too long, may block the oil lines and cause damage to the engine.

If the engine is run frequently and allowed to thoroughly warm up, most of this water will become vapor again and will be blown out through the crankcase breather.

If the engine is not run frequently and allowed to thoroughly warm up, this water will accumulate, mix with the engine oil and form a sludge that is harmful to the engine.

OIL COOLER

Motorcycles with a Twin Cam 103 or 110 engine are equipped with a factory installed oil cooler. Always keep the cooler clean

and free from dirt and debris. This will help maintain maximum cooling efficiency.

TRANSMISSION LUBRICATION

General

The transmission lubricant level should be checked monthly.

Refer to Table 44. The transmission should be drained and refilled with fresh lubricant at specified intervals.

NOTE

When checking the transmission lubricant level, the motorcycle should be leaning on the jiffy stand. If the motorcycle was recently moved or ridden, allow a short period of time to equalize lubricant level in the transmission compartments.

Check Lubricant Level

1. Park motorcycle on its jiffy stand.
2. See Figure 51. Remove the filler plug/dipstick and wipe off dipstick.

3. See Figure 52. Place back in filler hole but do not thread in. (Filler plug/dipstick should rest on top of threaded hole.) Remove filler plug/dipstick and observe lubricant level. Level should be between the full and low marks on the dipstick.

⚠ WARNING

Be sure that no lubricants or fluids get on tires, wheels or brakes when changing fluid. Traction can be adversely affected, which could result in loss of control of the motorcycle and death or serious injury. (00047d)

NOTICE

When draining or adding lubricant, do not allow dirt, debris or other contaminants to enter the engine. (00198a)

4. Add the recommended GENUINE Harley-Davidson lubricant as necessary. Refer to Table 34. Do not overfill or leakage may occur. The transmission fluid capacity is approximately 0.95 L (32 fl oz).
5. Inspect O-ring for tears or damage. Replace if required. Wipe any foreign material from plug.
6. Install filler plug/dipstick and tighten to 2.8–8.5 N·m (25–75 in-lbs).

Table 34. Recommended Lubricant

MODEL	LUBRICANT
All	FORMULA+ TRANSMISSION AND PRIMARY CHAIN LUBRICANT (Part No. 99851-05) or SYN3 20W50 OIL (Part No. 99824-03/00QT quart)

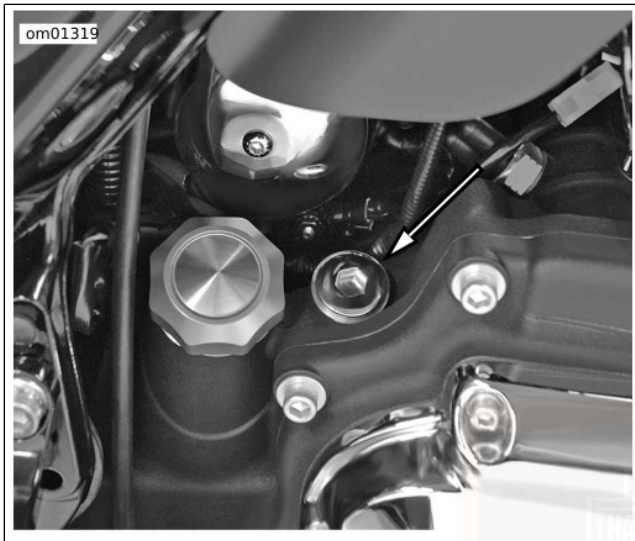

Figure 51. Transmission Filler Plug/Dipstick Location

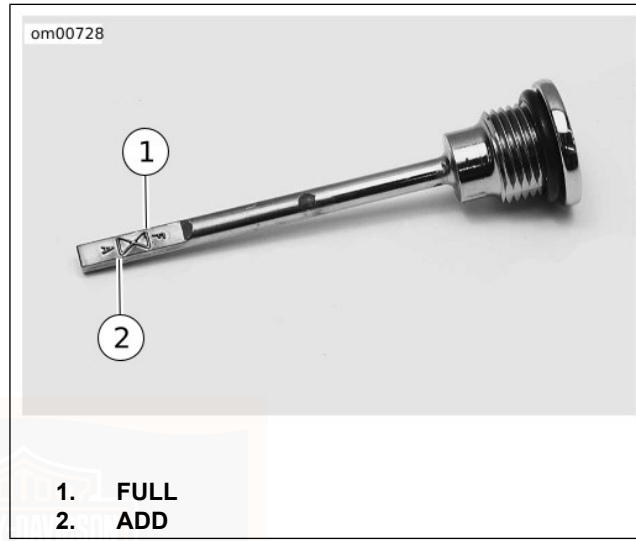

Figure 52. Transmission Filler Plug/Dipstick Lubricant Level

1. FULL
2. ADD

Changing Transmission Fluid

1. See Figure 51. Remove the threaded filler plug/dipstick.

NOTICE

When draining or adding lubricant, do not allow dirt, debris or other contaminants to enter the engine. (00198a)

⚠ WARNING

Be sure that no lubricants or fluids get on tires, wheels or brakes when changing fluid. Traction can be adversely affected, which could result in loss of control of the motorcycle and death or serious injury. (00047d)

2. See Figure 49. Remove transmission drain plug (1) and drain lubricant into a suitable container.

NOTE

Dispose of transmission lubricant in accordance with local regulations.

3. Inspect the drain plug O-ring for tears or damage. Replace if required. Wipe any foreign material from plug.
4. Install drain plug and tighten to 19–28.5 N·m (14–21 ft-lbs). Fill the transmission with 0.95 L (32 fl oz) of the recommended GENUINE Harley-Davidson lubricant. Refer to Table 34.

NOTE

Do not overfill or leakage may occur. The transmission fluid capacity is approximately 0.95 L (32 fl oz).

5. Install filler plug/dipstick and tighten to 2.8–8.5 N·m (25–75 in-lbs).
6. Start engine and carefully check for oil leaks around drain plug.

PRIMARY CHAINCASE LUBRICANT

General

NOTE

The chaincase lubricant level should be drained and refilled at specified intervals. Refer to Table 44.

Check Lubricant Level

1. Ride motorcycle until engine is warmed up to normal operating temperature.
2. Stand vehicle upright on a level surface, so that primary chaincase is level.

3. See Figure 53. Remove clutch inspection cover from primary chaincase cover.
4. Remove and discard seal ring from cover.
5. If the fluid level is visible through the clutch inspection cover opening, it is adequate. If necessary, add enough of the recommended GENUINE Harley-Davidson lubricant until it is visible along the bottom portion of the clutch assembly. Refer to Table 35.

Table 35. Recommended Lubricant

MODEL	LUBRICANT
All	FORMULA+ TRANSMISSION AND PRIMARY CHAIN LUBRICANT (Part No. 99851-05) or SYN3 20W50 OIL (Part No. 99824-03/00QT quart)

NOTICE

Do not overfill the primary chaincase with lubricant. Overfilling can cause rough clutch engagement, incomplete disengagement, clutch drag and/or difficulty in finding neutral at engine idle. (00199b)

6. Refer to Changing Chaincase Lubricant to install seal ring and clutch inspection cover.

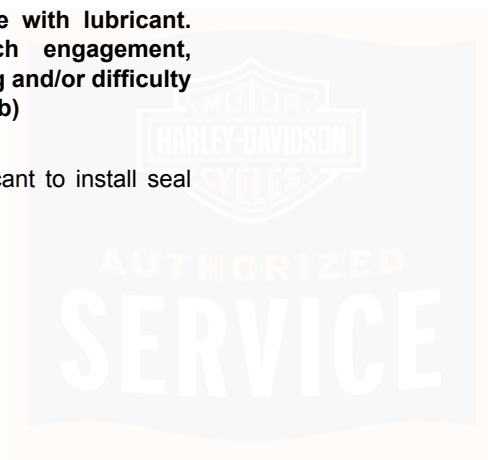

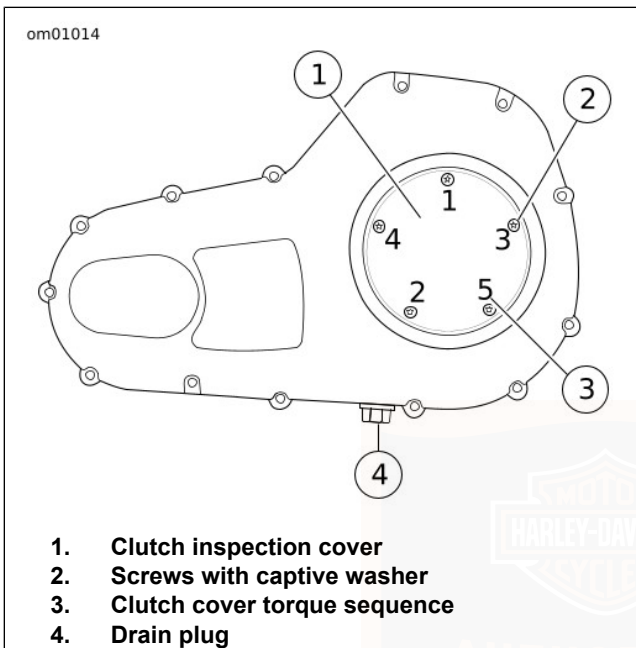

Figure 53. Primary Chaincase Cover

Changing Chaincase Lubricant

NOTICE

When draining or adding lubricant, do not allow dirt, debris or other contaminants to enter the engine. (00198a)

1. Ride motorcycle until engine is warmed to normal operating temperature.
2. See Figure 53. Remove clutch inspection cover from primary chaincase cover.
3. Remove drain plug (2) and drain lubricant into suitable container.

NOTE

Dispose of chaincase lubricant in accordance with local regulations.

4. Clean drain plug magnet. If magnet has accumulated excessive debris, inspect the condition of chaincase components.
5. Inspect drain plug O-ring for cuts, tears or deterioration. Replace as necessary.

6. Install drain plug and tighten to 19–28.5 N·m (14–21 ft-lbs).
7. Pour 1.12 L (38 fl oz) of the recommended GENUINE Harley-Davidson lubricant through the clutch inspection cover opening. Refer to Table 35.

NOTE

Add 1.33 L (45 fl oz) only if the primary chaincase or primary chaincase cover has been removed.

NOTICE

Do not overfill the primary chaincase with lubricant. Overfilling can cause rough clutch engagement, incomplete disengagement, clutch drag and/or difficulty in finding neutral at engine idle. (00199b)

⚠ WARNING

Be sure that no lubricants or fluids get on tires, wheels or brakes when changing fluid. Traction can be adversely affected, which could result in loss of control of the motorcycle and death or serious injury. (00047d)

8. Swab all lubricant from seal ring groove in clutch inspection cover and install **new** seal ring with nubs contacting ring groove walls.

9. See Figure 53. Install clutch inspection cover. Tighten screws in the sequence shown to 9.5–12.2 N·m (84–108 **in-lbs**).

CHECKING DRIVE BELT DEFLECTION

NOTE

Always use BELT TENSION GAUGE (PART NUMBER: HD-35381-A) to measure belt deflection. Do not rely on "feel" as this can result in belts that are under tensioned. Loose belts will fail due to "ratcheting" (jumping a tooth).

Check deflection:

- As part of pre-ride inspection.
 - At every scheduled service interval.
 - With transmission in neutral.
 - At loosest spot in belt.
 - With motorcycle at room temperature.
 - With motorcycle upright and rear wheel off the ground or on jiffy stand without rider or luggage.
1. Remove left side saddlebag.
 2. Slide O-ring on gauge toward 0 lbs (0 kg) mark.
 3. See Figure 54. Fit cradle against bottom of belt midway between transmission sprocket and rear sprocket.

4. Push upward on knob until O-ring slides to the 4.5 kg (10 lb) mark on the tool and compare belt deflection to scale on debris deflector.

NOTE

Each graduation on the scale represents 3.2 mm (1/8 in) of belt deflection.

5. Measure deflection at several locations around the belt. Select the loosest measurement and compare with specifications in Table 36. Adjust belt as necessary.

Table 36. Belt Deflection

MODEL	INCHES	MILLIMETERS
FLHX, FLTRX	1/4-5/16	6.4-7.9
Other models	3/8-7/16	9.5-11.1

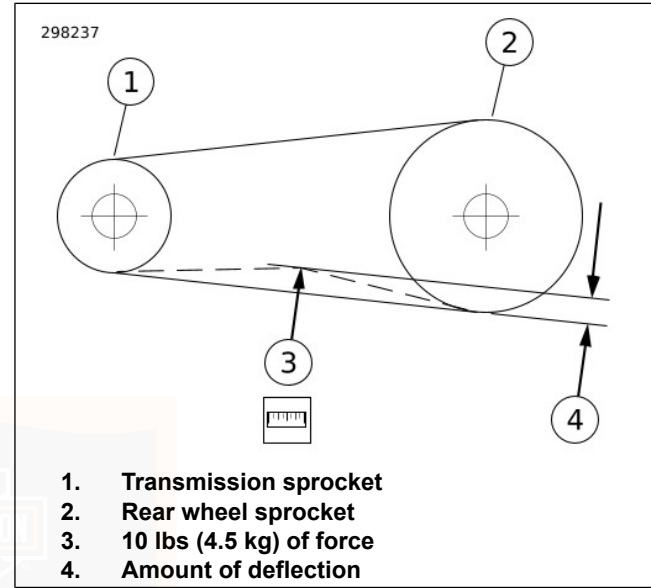

Figure 54. Checking Belt Deflection

CHASSIS LUBRICATION

Refer to Table 44 for all maintenance schedules.

NOTE

Use recommended special purpose grease for steering head bearings. Use a multipurpose chassis grease for other applications.

1. Lubricate clutch control cable (if equipped) at proper intervals.
2. Lubricate front brake hand lever and clutch control hand lever only if necessary.
3. Inspect rear fork pivot shaft bearings.
4. Pack the steering head bearings with fresh grease at proper intervals.
5. Lubricate the jiffy stand mechanism with LOCTITE SILVER GRADE ANTI-SEIZE at proper intervals.

NOTE

For model specific information regarding the chassis lubrication, refer to the appropriate Service Manual or see a Harley-Davidson dealer.

MISCELLANEOUS LUBRICATION

Hinges, Latches, Etc.

Lubricate the rub points of latches and hinges using Harley® Lube (Part No. 94968-09) as required.

Lubricate the fingers on the saddlebag latches where they engage the hinge.

OIL APPLICATIONS

Refer to Table 44 for all control connections and parts. Vehicle should be oiled at regular intervals, particularly after washing motorcycle or driving in wet weather.

FRONT FORK OIL

Refer to Table 44. Have a Harley-Davidson dealer drain the front fork oil and refill at proper intervals. If fork does not appear to be working properly or an appreciable amount of oil leakage should develop, see a Harley-Davidson dealer. If there is insufficient oil in either side of fork, the rebound action will be incorrect.

FUEL FILTER

Fuel injected motorcycles have a fuel filter attached to the fuel pump.

NOTE

For model specific information regarding fuel filter maintenance, refer to the appropriate Service Manual or see a Harley-Davidson dealer.

CLUTCH

NOTICE

The clutch control cable must be oiled and adjusted periodically to compensate for lining wear. Failure to oil and adjust the clutch control cable can result in equipment damage. (00203c)

The need for attention to clutch and controls will be indicated by the clutch slipping under load or dragging when released. In this situation, check the control cable adjustment first. See a Harley-Davidson dealer for proper service.

HYDRAULIC LIFTERS

The hydraulic lifters are self-adjusting. They automatically adjust length to compensate for engine expansion and valve mechanism wear. This keeps the valve mechanism free of lash when the engine is running.

When starting an engine which has been turned off even for a few minutes, the valve mechanism may be slightly noisy until the hydraulic units completely refill with oil. If at any time the valve mechanism becomes abnormally noisy, other than for a short period immediately after engine is started, it is an indication that one or more of the hydraulic units may not be functioning properly.

Always check the engine oil level first since normal circulation of oil through the engine is necessary for proper operation of the hydraulic lifters.

If engine oil is at the proper level, the lifters may not be functioning properly because of dirt in the oil supply passages leading to the lifter units. See a Harley-Davidson dealer for service.

FRONT FORK BEARINGS

▲ WARNING

Adjustments to steering head bearings should be performed by a Harley-Davidson dealer. Improperly adjusted bearings can adversely affect handling and stability, which could result in death or serious injury. (00051b)

Refer to Table 44. Check front fork for proper bearing adjustment and lubricate bearings at proper intervals.

With motorcycle front end raised off the floor, be sure front fork turns freely without any binding or interference and that there is no appreciable front to rear fork shake indicating excessive bearing looseness. Steering head bearings should be adjusted according to Service Manual procedure, if necessary.

REAR FORK PIVOT SHAFT

Refer to Table 44. Check the tightness of the rear fork pivot shaft fastener at proper intervals.

NOTE

For model specific information regarding the rear fork pivot shaft, refer to the appropriate Service Manual or see a Harley-Davidson dealer.

BRAKES

▲ WARNING

Inspect brake pads for wear at service maintenance intervals. If you ride under adverse conditions (steep hills, heavy traffic, etc.), inspect more frequently. Excessively worn brake pads can lead to brake failure, which could result in death or serious injury. (00052a)

NOTE

- *Master cylinder cover specifies correct brake fluid.*
 - *Use only Harley-Davidson D.O.T. 4 HYDRAULIC BRAKE FLUID (Part No. 99953-99A).*
 - *Do not mix D.O.T. 4 with D.O.T. 5 brake fluid.*
1. Refer to Table 44. Check brake pads and brake discs for wear at proper intervals.

2. Check the fluid level in the master cylinder reservoirs at proper intervals.
3. If level is low, clean dirt and debris from reservoir cover before removing.

NOTE

If the brake system is not leaking, there should never be a need to add fluid. If the fluid level is low, the pads are probably worn and need to be replaced. By replacing the pads, the fluid level will rise.

NOTICE

DOT 4 brake fluid will damage painted and body panel surfaces it comes in contact with. Always use caution and protect surfaces from spills whenever brake work is performed. Failure to comply can result in cosmetic damage. (00239c)

▲ WARNING

Contact with DOT 4 brake fluid can have serious health effects. Failure to wear proper skin and eye protection could result in death or serious injury.

- **If inhaled: Keep calm, remove to fresh air, seek medical attention.**

- **If on skin: Remove contaminated clothing. Rinse skin immediately with plenty of water for 15-20 minutes. If irritation develops, seek medical attention.**
- **If in eyes: Wash affected eyes for at least 15 minutes under running water with eye lids held open. If irritation develops, seek medical attention.**
- **If swallowed: Rinse mouth and then drink plenty of water. Do not induce vomiting. Contact Poison Control. Immediate medical attention required.**
- **See Safety Data Sheet (SDS) for more details available at sds.harley-davidson.com**

(00240e)

4. Add D.O.T. 4 HYDRAULIC BRAKE FLUID (Part No. 99953-99A) if necessary.

NOTE

Use only D.O.T. 4 HYDRAULIC BRAKE FLUID (Part No. 99953-99A) approved for brake system use and available from your Harley-Davidson dealer.

Harley-Davidson has provided your new motorcycle with the optimum brake pad friction material available. It is selected to give the best performance possible under dry, wet and high operating temperature conditions. It exceeds all regulatory requirements currently in effect. However, during some braking

conditions you may experience noise. This is normal for this friction material.

⚠ WARNING

Brakes are a critical safety component. Contact a Harley-Davidson dealer for brake repair or replacement. Improperly serviced brakes can adversely affect brake performance, which could result in death or serious injury. (00054a)

See Figure 55. Visual inspection of brake pads can be made without removing the caliper. View the lower area of each caliper with a flashlight.

⚠ WARNING

Perform routine scheduled brake maintenance. Lack of maintenance at recommended intervals can adversely affect brake performance, which could result in death or serious injury. (00055a)

⚠ WARNING

Always replace brake pads in complete sets for correct and safe brake operation. Improper brake operation could result in death or serious injury. (00111a)

The rear brake outer pad on all models can be measured from the caliper bracket side using a thin plastic 152.4 mm (6.0 in)

rule. Place the rule against the brake disc through the space alongside the caliper.

The outer surface of the brake pad backing plate should measure 0.4 mm (0.016 in) or more away from the brake disc.

NOTE

- If the brake pad friction material is 0.4 mm (0.016 in) thick or less, the pads must be replaced immediately.
- Always replace brake pads in pairs.

⚠ WARNING

Be sure wheel and brake caliper are aligned. Riding with a misaligned wheel or brake caliper can cause the brake disc to bind and lead to loss of control, which could result in death or serious injury. (00050a)

Check rear brake caliper position on rear brake disc. Disc should run true within brake caliper.

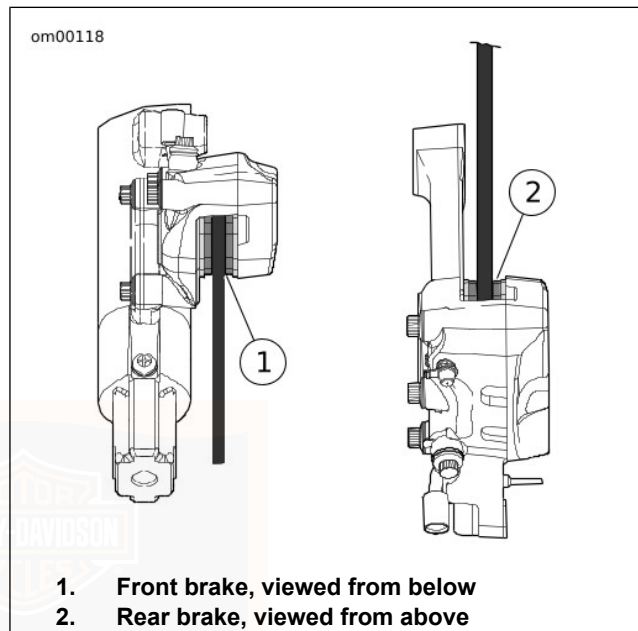

Figure 55. Brake Friction Material

TIRES

See SPECIFICATIONS > SPECIFICATIONS (Page 21) for tire pressures and sizes.

- Be sure to keep tires properly inflated.

- Follow tire data for correct cold tire inflation pressures.
- Check before riding when tires are cold.
- Do not over-inflate tires.

▲ WARNING

Do not inflate tire beyond maximum pressure as specified on sidewall. Over inflated tires can blow out, which could result in death or serious injury. (00027b)

▲ WARNING

Match tires, tubes, rim strips or seals, air valves and caps to the correct wheel. Contact a Harley-Davidson dealer. Mismatching can lead to tire damage, allow tire slippage on the wheel or cause tire failure, which could result in death or serious injury. (00023c)

Check inflation pressure and inspect tread for punctures, cuts, breaks, etc., at least weekly if in daily use. Check before each trip if used occasionally.

▲ WARNING

Be sure tires are properly inflated, balanced, undamaged, and have adequate tread. Inspect your tires regularly and see a Harley-Davidson dealer for replacements. Riding with excessively worn, unbalanced, improperly inflated, overloaded or damaged tires can lead to tire failure and adversely affect stability and handling, which could result in death or serious injury. (00014b)

Same as original equipment tires should be used. Other tires may not fit correctly, could adversely affect handling, and may be hazardous to use.

▲ WARNING

Tires are a critical safety component. Contact a Harley-Davidson dealer for tire repair or replacement. Improper tire service can adversely affect stability and handling, which could result in death or serious injury. (00057a)

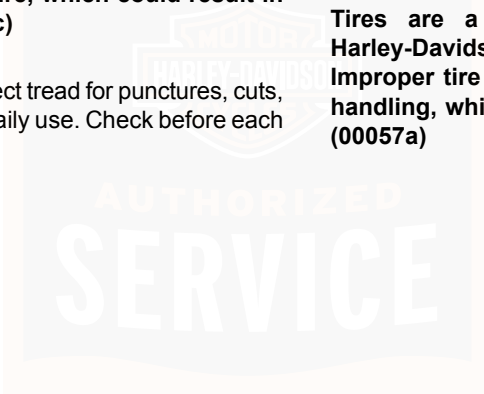

▲ WARNING

Replace punctured or damaged tires. In some cases, small punctures in the tread area may be repaired from within the removed tire by a Harley-Davidson dealer. Speed should NOT exceed 80 km/h (50 mph) for the first 24 hours after repair, and the repaired tire should NEVER be used over 129 km/h (80 mph). Failure to follow this warning could lead to tire failure and result in death or serious injury. (00015b)

▲ WARNING

Striking an object, such as a curb or pothole can cause internal tire damage. If an object is struck, have the tire inspected immediately inside and out by a Harley-Davidson dealer. A damaged tire can fail while riding and adversely affect stability and handling, which could result in death or serious injury. (00058b)

TIRE REPLACEMENT

Inspection

▲ WARNING

Replace tire immediately with a Harley-Davidson specified tire when wear bars become visible or only 1 mm (1/32 in) tread depth remains. Riding with a worn tire could result in death or serious injury. (00090c)

See Figure 56. Arrows on tire sidewalls pinpoint location of wear bar indicators.

Tread wear indicator bars will appear on tire tread surfaces when 0.8 mm (1/32 in) or less of tire tread remains. See Figure 57. Always replace tires before the tread wear indicator bars appear.

When To Replace Tires

New tires are needed if any of the following conditions exist:

1. Tread wear indicator bars become visible on the tread surfaces.
2. Tire cords or fabric become visible through cracked sidewalls, snags or deep cuts.
3. A bump, bulge or split in the tire.
4. Puncture, cut or other damage to the tire that cannot be repaired.

When installing tires on rims, do not rely on tread design to determine direction of rotation. Always be sure the rotational arrows molded into the sidewalls point in the direction of rotation when the vehicle is moving forward.

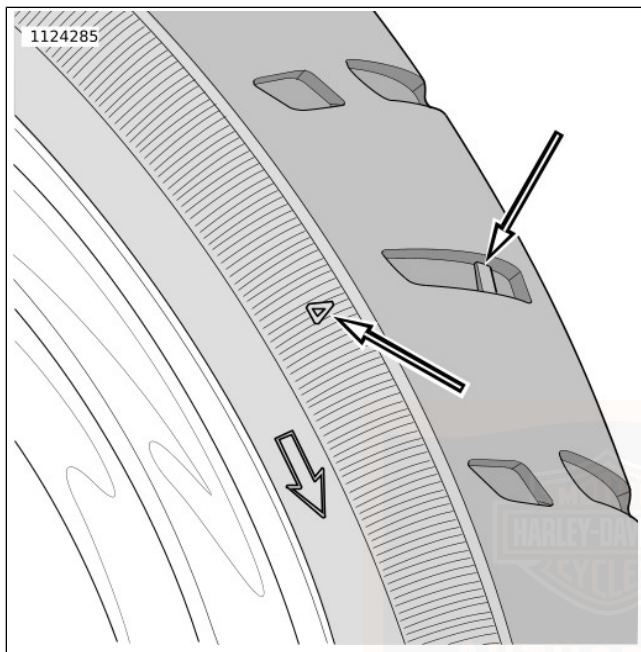

Figure 56. Tire Sidewall Wear Bar Locator

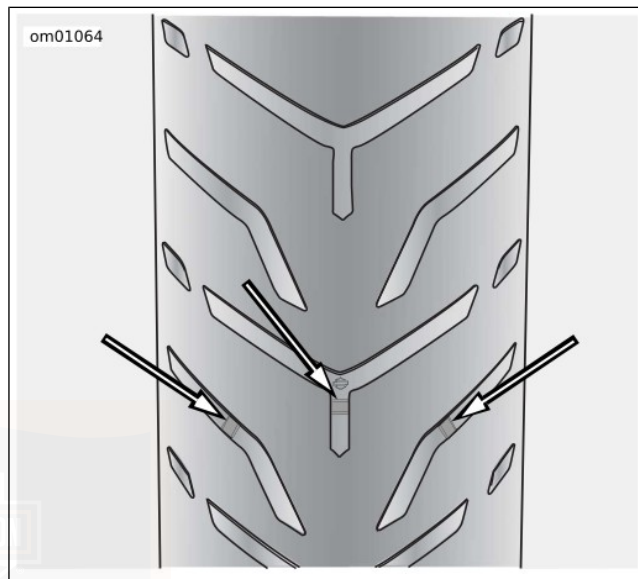

Figure 57. Wear Bar Appearance

SHOCK ABSORBERS

Inspect shock absorbers and rubber bushings for leaks and bushing deterioration at proper intervals.

SPARK PLUGS

⚠ WARNING

Disconnecting spark plug cable with engine running can result in electric shock and death or serious injury. (00464b)

⚠ CAUTION

Do NOT pull on any electrical wires. Pulling on electrical wires may damage the internal conductor causing high resistance, which may result in minor or moderate injury. (00168a)

Refer to Table 44 before servicing spark plugs. Check the spark plugs at proper intervals.

1. Disconnect spark plug cables from plugs by pulling up on the molded connector caps.
2. Check spark plug type. Only use those spark plugs specified for your model motorcycle.

NOTE

*If a torque wrench is not available, tighten **new** spark plugs finger-tight and then tighten an additional one-quarter turn with a spark plug wrench.*

3. Check spark plug gap against specifications table.

4. Always tighten to the proper torque. Spark plugs must be tightened to the torque specified for proper heat transfer.
5. Connect each molded connector cap until the cap snaps firmly into place over the spark plug.

IGNITION

The engine in your motorcycle has been designed specifically to achieve optimum fuel economy within exhaust emission controls. Factory programmed ignition characteristics provide maximum engine performance and driveability.

AIR CLEANER

See Figure 58. The engine air cleaner is a paper/wire mesh air filter element.

Refer to Table 44. Remove air cleaner cover and inspect filter element at proper intervals. When operated under dusty conditions, inspect more often.

The paper/wire mesh air filter element should be washed in lukewarm water with a mild detergent.

⚠ WARNING

Compressed air can pierce the skin and flying debris from compressed air could cause serious eye injury. Wear safety glasses when working with compressed air. Never use your hand to check for air leaks or to determine air flow rates. (00061a)

- Allow filter to either air dry or blow it dry, from the inside, with low pressure air.
- Do not use an air cleaner filter oil on the Harley-Davidson paper/wire mesh air filter element.

NOTICE

Install air filter before running engine. Failure to do so can draw debris into the engine and could result in engine damage. (00207a)

Install baseplate gasket, air filter element and bracket if removed. Tighten bracket screws to 12.2–14.9 N·m (108–132 **in-lbs**).

When installing air cleaner cover, apply a drop of LOCTITE THREADLOCKER 243 (blue) to the threads of the cover screw and tighten to 4.1–6.8 N·m (36–60 **in-lbs**).

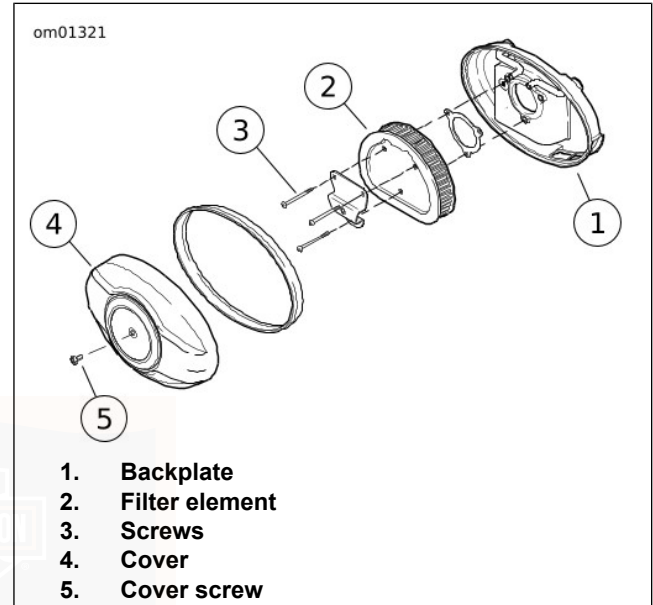

Figure 58. Air Cleaner: Twin Cam Models
HEADLAMP: SINGLE HEADLAMP MODELS

Removal

1. Remove screw at bottom of headlamp door (chrome ring). Remove headlamp door.

2. See Figure 59. Remove screws securing headlamp assembly.
3. Remove headlamp connector from headlamp bulb.



Figure 59. Headlamp Retaining Screws, typical

Bulb Replacement

NOTICE

When replacement is required, use only the specified sealed beam unit or bulb, available from a Harley-Davidson dealer. An improper wattage sealed beam or bulb, can cause charging system problems. (00209a)

NOTE

The headlamp uses a replaceable quartz halogen bulb which is very delicate and must be handled with care.

1. Remove headlamp assembly.
2. Remove rubber boot at back of housing.
3. See Figure 60. Release wire retaining clip (1) from retainer (2). Swing wireform out of the way.

NOTE

It may be necessary to loosen retainer screw 1/2-1 turn to release wireform.

▲ WARNING

Handle bulb carefully and wear eye protection. Bulb contains gas under pressure, which, if not handled carefully, could cause serious eye injury. (00062b)

4. Remove and discard bulb.

NOTICE

Never touch the quartz bulb. Fingerprints will etch the glass and decrease bulb life. Handle the bulb with paper or a clean, dry cloth. Failure to do so could result in bulb damage. (00210b)

5. Install **new** bulb. Align the tab on the bulb with the notch in the headlamp housing.
6. See Figure 60. Rotate wire retaining clip (1) into place and latch under lip of retainer (2).

NOTE

If retainer screw was loosened to release wire retaining clip, hold retainer in place and tighten screw until snug. Verify that reflector cone is still centered under decorative logo. If it is not, loosen retainer screw and repeat step until the proper results are achieved.

7. Install rubber boot at back of housing.
8. **HDI models:** Rotate position lamp bulb retainer 1/4 turn counterclockwise to remove. Replace bulb and install bulb retainer in lamp housing.
9. Install headlamp assembly.

sm05135

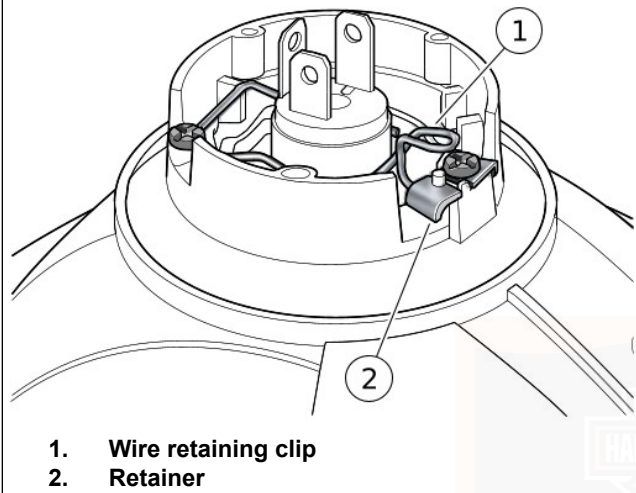

Figure 60. Wire Retaining Clip

Installation

1. Install headlamp connector on headlamp bulb.
2. Install headlamp assembly and tighten screws to:
 - a. **Non-fairing equipped:** 1–2 N·m (9–18 in-lbs).

b. **Fairing equipped:** 2.5–3.6 N·m (22–32 in-lbs).

3. Fit the headlamp door spring into slot at top of headlamp housing and secure the headlamp door (chrome ring) with screw. Tighten to 1–2 N·m (9–18 in-lbs).

HEADLAMP BULB REPLACEMENT: DUAL HEADLAMP MODELS

Removal

1. Carefully pry headlamp bezel from front of motorcycle.
2. Remove four screws securing headlamp assembly to trim ring/adjuster assembly.
3. Disconnect headlamp harness from bulb and remove headlamp housing assembly.

Bulb Replacement

NOTICE

When replacement is required, use only the specified sealed beam unit or bulb, available from a Harley-Davidson dealer. An improper wattage sealed beam or bulb, can cause charging system problems. (00209a)

NOTE

The headlamp uses a replaceable quartz halogen bulb which is bulb is very delicate and must be handled with care.

1. See Figure 61. Remove rubber boot (1).
2. Rotate retainer (2) counter-clockwise and remove.

⚠ WARNING

Handle bulb carefully and wear eye protection. Bulb contains gas under pressure, which, if not handled carefully, could cause serious eye injury. (00062b)

3. Remove and discard bulb.

NOTICE

Never touch the quartz bulb. Fingerprints will etch the glass and decrease bulb life. Handle the bulb with paper or a clean, dry cloth. Failure to do so could result in bulb damage. (00210b)

4. See Figure 61. Install **new** bulb in headlamp housing. Be sure tab (5) on bulb is aligned with slot (6) in bulb housing.
5. Install retainer (2) and rotate clockwise to secure.

6. Install rubber boot (1) over retainer until flush with base of bulb socket.
7. **HDI models:** Rotate position lamp bulb retainer 1/4 turn counterclockwise to remove. Replace bulb and install bulb retainer in lamp housing.

Installation

1. Install headlamp assembly and tighten screws to 1.7–2.8 N·m (15–25 in-lbs).
2. Install headlamp bezel.

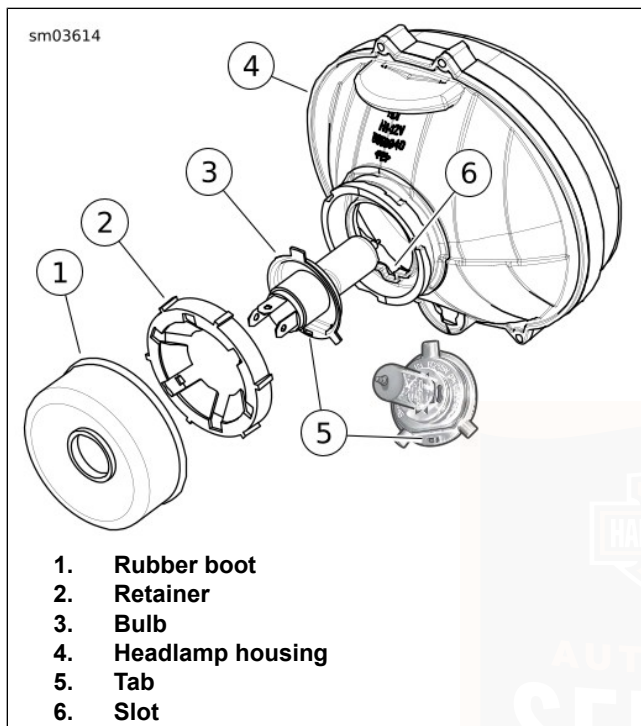

Figure 61. Headlamp Housing Assembly

HEADLAMP ALIGNMENT

⚠ WARNING

The automatic-on headlamp feature provides increased visibility of the rider to other motorists. Be sure headlamp is on at all times. Poor visibility of rider to other motorists can result in death or serious injury. (00030b)

NOTE

Vehicles with multiple beam headlamps that are individually aimed should be adjusted so both lamps converge into one pattern.

1. Verify that front and rear tire inflation pressures are correct and that suspension is adjusted to the weight of the principal rider. See OWNER MANUAL > SPECIFICATIONS (Page 21).
2. Fill fuel tank or add ballast to equal the weight of the fuel needed.

NOTE

See Figure 62. To aid in properly placing the motorcycle, a perpendicular line (1) can be drawn on the floor. For best results, choose an area with minimum light.

3. See Figure 62. Draw a vertical line (2) on the wall.

4. Position motorcycle so that front axle is 7.6 m (25 ft) from wall.

NOTE

As the weight of the rider will compress the suspension slightly, have a person whose weight is approximately the same as that of the principal rider sit on the motorcycle.

5. With the vehicle laden and upright, point the front wheel straight forward at wall and measure the distance (4) from the floor to the center of the HIGH BEAM bulb.
6. Draw a horizontal line (5) through the vertical line on the wall that is 53.3 mm (2.1 in) lower than the measured bulb centerline.

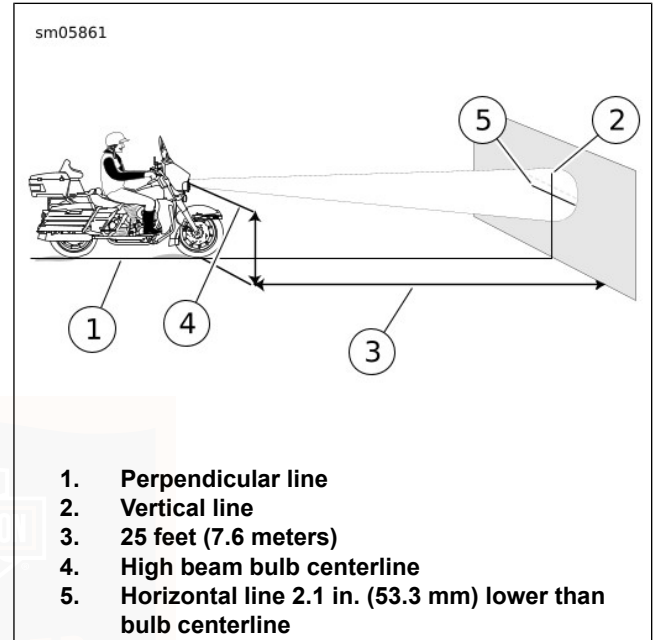

Figure 62. Check Headlamp Alignment

7. See Figure 62. Verify headlamp alignment. Turn the ignition switch to IGNITION and set the headlamp switch to HIGH beam.
 - a. The center of the hot spot (brightest area of light beam) should be centered where the two lines intersect.
 - b. Adjust headlamp alignment if necessary.

HEADLAMP ADJUSTMENT: SINGLE HEADLAMP MODELS

NOTE

Headlamp adjustment can be performed without removing the headlamp trim ring.

1. See Figure 63. Using adjuster slots in trim ring, insert Phillips screwdriver between headlamp trim ring and rubber gasket.
 - a. **Horizontal:** Turn the horizontal adjusting screw to adjust light beam left and right.
 - b. **Vertical:** Turn the vertical adjusting screw to adjust light beam up and down.
2. Adjust the light beam until it is centered as shown in Figure 62.

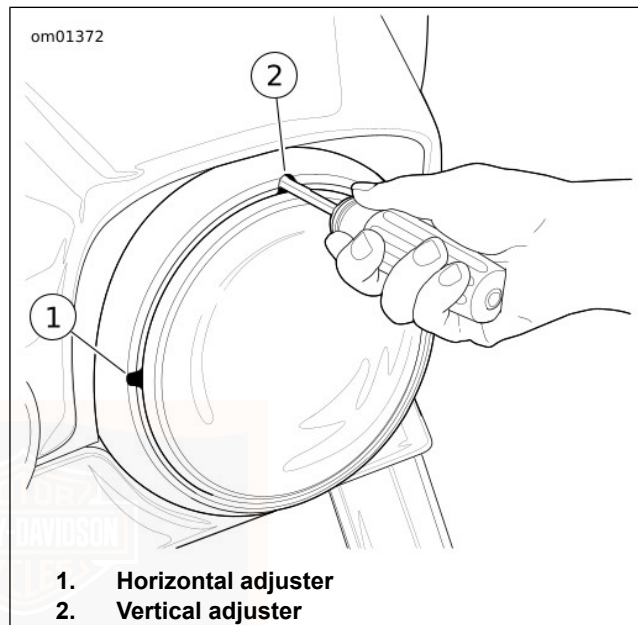

Figure 63. Headlamp Adjusters (typical)

HEADLAMP ADJUSTMENT: DUAL HEADLAMP MODELS

1. See Figure 64. Rotate the hex adjusters (metric) located near the bottom edge of the inner fairing. Refer to Table 37 for adjuster rotation.
 - a. **Horizontal:** Turn either the left or right adjuster to adjust the light beam left and right.
 - b. **Vertical:** Turn both adjusters equally to adjust the light beam up and down.
2. Adjust the light beam until it is centered as shown in Figure 62.

Table 37. Hex Adjuster Rotation

HEX ADJUSTER	ROTATION	BEAM MOVEMENT
Left only	clockwise	to the right
Right only	counterclockwise	
Left only	counterclockwise	to the left
Right only	clockwise	
Left and right equally	clockwise	upward
Left and right equally	counterclockwise	downward



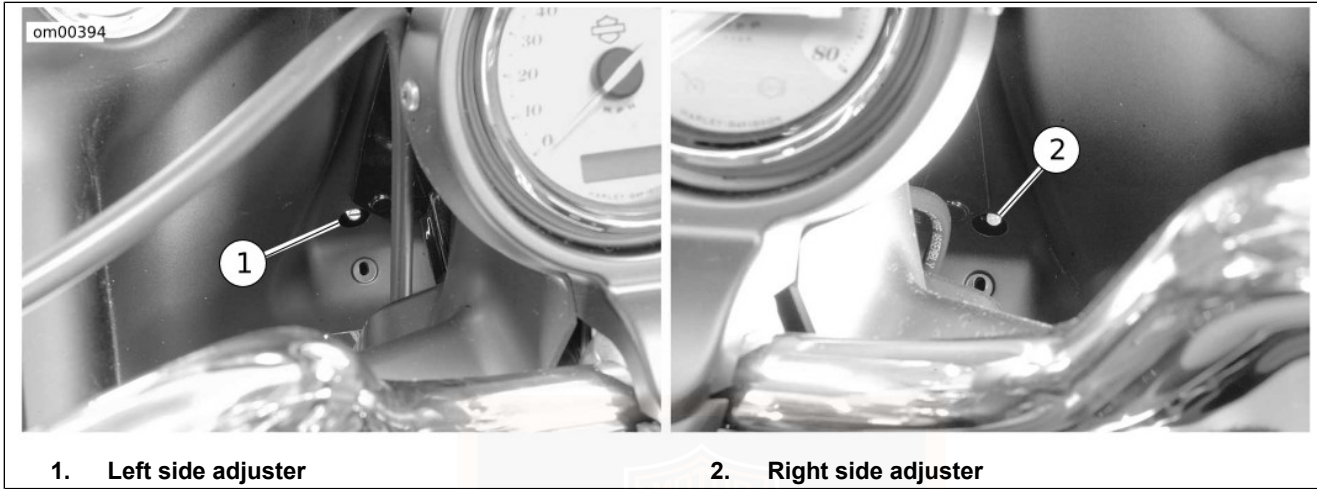

1. Left side adjuster

2. Right side adjuster

Figure 64. Headlamp Adjusters: Dual Headlamp Models

AUXILIARY LAMPS

For models equipped with auxiliary lamps, see a Harley-Davidson dealer or service manual for bulb replacement or alignment.

TURN SIGNAL BULB REPLACEMENT: BULLET STYLE

1. See Figure 65. Insert a coin or the blade of a small screwdriver into the notch at the bottom of the lens cap. Carefully twist until the lens cap pops out of the lamp housing.
2. Push bulb in and rotate counterclockwise. Pull bulb from socket.

3. Inspect condition of electrical contacts in socket. If necessary, clean with a small wire brush and electrical contact cleaner.
4. Coat base of **new** bulb with ELECTRICAL CONTACT GREASE (Part No. 99861-90).
5. Align pins on bulb with pin guides in bulb socket. Push **new** bulb in and turn clockwise to lock in place.
6. Snap lens cap back into the lamp holder. Rotate lens to position notch at bottom of lamp.

▲ WARNING

Be sure that all lights and switches operate properly before operating motorcycle. Low visibility of rider can result in death or serious injury. (00316a)

7. Test turn signal operation.

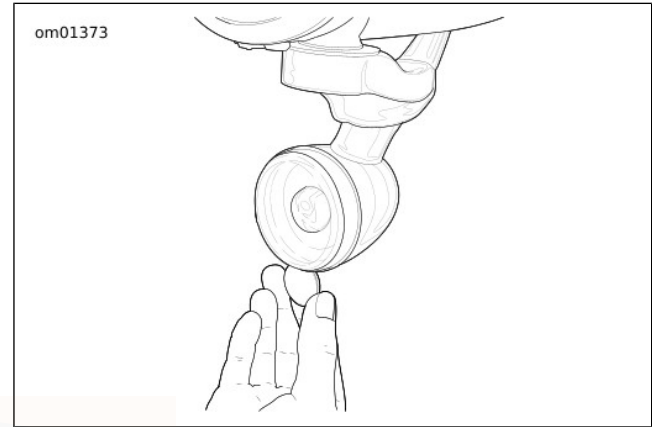

Figure 65. Lens Cap Notch

**TURN SIGNAL BULB REPLACEMENT:
FLAT LENS STYLE**

1. See Figure 66. Remove two screws to release lens from lamp housing.
2. Push bulb in and rotate counterclockwise to remove bulb from socket.
3. Inspect condition of electrical contacts in socket. If necessary, clean with a small wire brush and electrical contact cleaner.

4. Liberally apply ELECTRICAL CONTACT GREASE (Part No. 99861-90) to contacts in socket and at bottom of **new** bulb.
5. Orient index pins on **new** bulb with pin guides inside bulb socket. Push bulb in and turn clockwise to lock in place.
6. Seat lens in lamp and install two screws.

⚠ WARNING

Be sure that all lights and switches operate properly before operating motorcycle. Low visibility of rider can result in death or serious injury. (00316a)

7. Test turn signal operation.

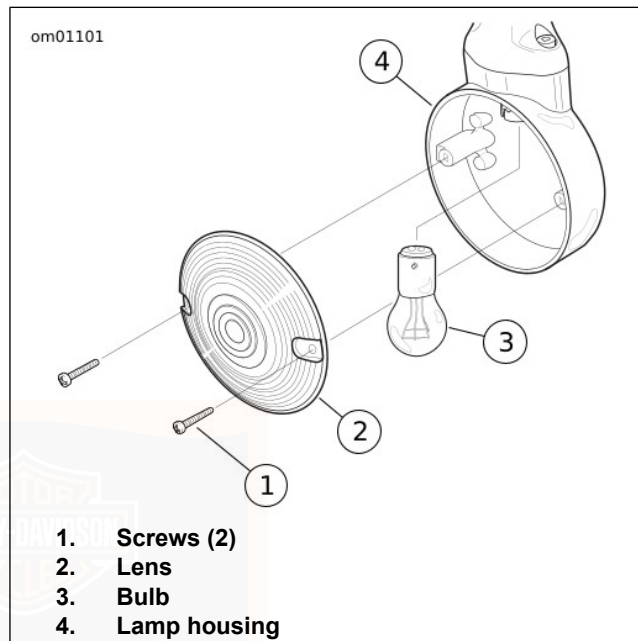

**Figure 66. Turn Signal Lamp Assembly: Flat Lens Style
TAIL LAMP BULB REPLACEMENT**

Removal

1. Remove two screws to release tail lamp assembly from chrome base.

2. See Figure 67. Disconnect tail lamp connector (3).
3. Rotate bulb socket (4) 1/4 turn counterclockwise and remove from tail lamp assembly. Pull bulb from socket.

Installation

1. Coat base of **new** bulb with ELECTRICAL CONTACT GREASE (Part No. 99861-90). Install **new** bulb in socket.
2. Insert socket (4) into tail lamp assembly and rotate 1/4 turn clockwise.
3. See Figure 67. Connect tail lamp connector (3).
4. Place tail lamp into position against chrome base.

NOTE

Over tightening screws can crack the lens.

5. Install two screws and tighten to 2.3–2.7 N·m (20–24 in-lbs).

▲ WARNING

Be sure that all lights and switches operate properly before operating motorcycle. Low visibility of rider can result in death or serious injury. (00316a)

6. Test tail lamp operation.

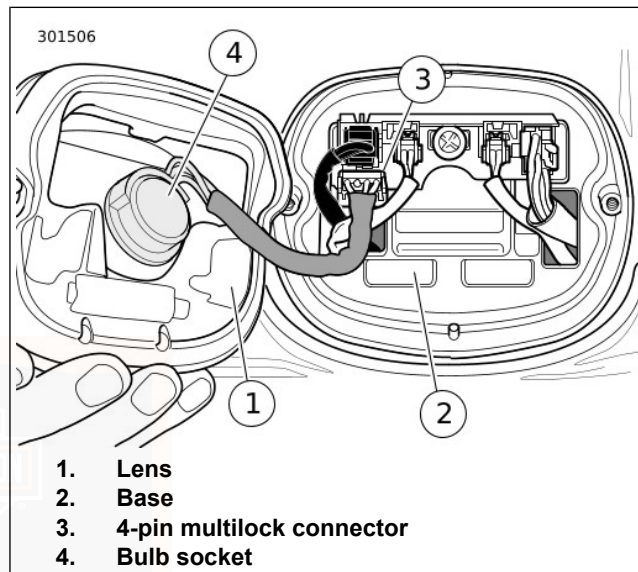

Figure 67. Tail Lamp Assembly

ALTERNATOR/VOLTAGE REGULATOR

Charging Rate

The alternator output is controlled and changed to direct current by the voltage regulator.

- The voltage regulator increases charging rate when battery is low or lamps are lit.
- The voltage regulator decreases charging rate when battery charge is up.

NOTICE

It is possible to overload the vehicle's charging system by adding too many electrical accessories. If the combined electrical accessories operating at any one time consume more electrical current than the vehicle's charging system can produce, the electrical consumption can discharge the battery and cause damage to the vehicle's electrical system. (00211d)

A battery voltage LED in the instruments will light up when voltage is either too low or too high.

NOTE

- *This unit requires no interval attention. If any electrical system trouble is experienced that might be traceable to the alternator or voltage regulator, the motorcycle should be taken to a Harley-Davidson dealer who has the necessary electrical testing equipment to give the required attention.*
- *For model specific information regarding the voltage regulator, refer to the appropriate Service Manual or see a Harley-Davidson dealer.*

BATTERY: GENERAL

Type

Your motorcycle uses a permanently sealed, maintenance-free, lead/calcium and sulfuric acid battery. All batteries are shipped precharged and ready to be put into service. Do not attempt to open the battery for any reason.

Table 38. Antidotes for Battery Acid

CONTACT	TREATMENT
External	Flush with water.
Internal	Drink large quantities of milk or water, followed by milk of magnesia, vegetable oil or beaten eggs. Get immediate medical attention.
Eyes	Flush with water. Get immediate medical attention.

⚠ WARNING

Batteries contain sulfuric acid, which could cause severe burns to eyes and skin. Wear a protective face shield, rubberized gloves and protective clothing when working with batteries. KEEP BATTERIES AWAY FROM CHILDREN. (00063a)

⚠ WARNING

Explosive hydrogen gas, which escapes during charging, could cause death or serious injury. Charge battery in a well-ventilated area. Keep open flames, electrical sparks and smoking materials away from battery at all times. **KEEP BATTERIES AWAY FROM CHILDREN.** (00065a)

⚠ WARNING

Batteries, battery posts, terminals and related accessories contain lead and lead compounds, and other chemicals known to the State of California to cause cancer, and birth defects or other reproductive harm. Wash hands after handling. (00019e)

⚠ WARNING

Never remove warning label from battery. Failure to read and understand all precautions contained in warning, could result in death or serious injury. (00064b)



om00618



1



2



3



4



5



6

<p>NON-SPILLABLE</p> <p>This is a ready filled, activated SEALED BATTERY. NEVER remove strip. Refer to owner's manual or instruction sheet for charging procedure.</p>	     	<p>! DANGER/POISON 3-4580</p> <table border="1"><tr><td><p>SHIELD EYES. EXPLOSIVE GASES CAN CAUSE BLINDNESS OR INJURY.</p></td><td><p>NO SPARKS FLAMES SMOKING</p></td><td><p>SULFURIC ACID CAN CAUSE BLINDNESS OR SEVERE BURNS.</p></td><td><p>FLUSH EYES IMMEDIATELY WITH WATER. GET MEDICAL HELP FAST.</p></td></tr></table>	 <p>SHIELD EYES. EXPLOSIVE GASES CAN CAUSE BLINDNESS OR INJURY.</p>	 <p>NO SPARKS FLAMES SMOKING</p>	 <p>SULFURIC ACID CAN CAUSE BLINDNESS OR SEVERE BURNS.</p>	<p>FLUSH EYES IMMEDIATELY WITH WATER. GET MEDICAL HELP FAST.</p> 
 <p>SHIELD EYES. EXPLOSIVE GASES CAN CAUSE BLINDNESS OR INJURY.</p>	 <p>NO SPARKS FLAMES SMOKING</p>	 <p>SULFURIC ACID CAN CAUSE BLINDNESS OR SEVERE BURNS.</p>	<p>FLUSH EYES IMMEDIATELY WITH WATER. GET MEDICAL HELP FAST.</p> 			
<p>KEEP OUT OF REACH OF CHILDREN. DO NOT OPEN BATTERY.</p>						

1. Contents are corrosive
2. Wear safety glasses
3. Contents are explosive

4. Keep flames away
5. Read instructions
6. Keep away from children

Figure 68. Battery Warning Label



Figure 69. Battery Warning Label

Voltmeter Test

Refer to Table 39. The voltmeter test provides a general indicator of battery condition. Check the voltage of the battery to verify that it is in a 100 percent fully-charged condition. If the open circuit (disconnected) voltage reading is below 12.6

V, charge the battery and then re-check the voltage after the battery has set for one to two hours.

Table 39. Voltmeter Test

READING IN VOLTS	PERCENT OF CHARGE
12.7	100
12.6	75
12.3	50
12.0	25
11.8	0

Cleaning and Inspection

Battery top must be clean and dry. Dirt and electrolyte on top of the battery can cause battery to self-discharge.

1. Clean battery top.
2. Clean cable connectors and battery terminals using a wire brush or fine grit sandpaper to remove any oxidation.
3. Inspect and clean the battery screws, clamps and cables. Check for breakage, loose connections and corrosion.
4. Check the battery posts for melting or damage caused by overtightening.
5. Inspect the battery for discoloration, a raised top or a warped or distorted case. This might indicate that the battery has been frozen, overheated or overcharged.

6. Inspect the battery case for cracks or leaks.

Charging

Never charge a battery without first reviewing the instructions for the charger being used. In addition to the manufacturer's instructions, follow these general safety precautions.

Charge the battery if any of the following conditions exist:

- Vehicle lamps appear dim.
- Electric starter sounds weak.
- Battery has not been used for an extended period of time.

⚠ WARNING

Explosive hydrogen gas, which escapes during charging, could cause death or serious injury. Charge battery in a well-ventilated area. Keep open flames, electrical sparks and smoking materials away from battery at all times. KEEP BATTERIES AWAY FROM CHILDREN. (00065a)

⚠ WARNING

Batteries contain sulfuric acid, which could cause severe burns to eyes and skin. Wear a protective face shield, rubberized gloves and protective clothing when working with batteries. KEEP BATTERIES AWAY FROM CHILDREN. (00063a)

1. Perform a voltmeter test to determine the state of charge. If battery needs to be charged, proceed to the next step.
2. Place the battery on a level surface.

NOTE

- *The figures in Table 40 show typical charging times. Charge times may vary. When using automatic chargers, allow the charger to determine when charging is complete.*
- *Do not use chargers with excessively high voltage designed for flooded batteries or excessively high current designed for much larger batteries. Charging should be limited to no more than 5 amps at no more than 14.6 volts.*

⚠ WARNING

Unplug or turn OFF battery charger before connecting charger cables to battery. Connecting cables with charger ON can cause a spark and battery explosion, which could result in death or serious injury. (00066a)

⚠ WARNING

Connect positive (+) battery cable first. If positive (+) cable should contact ground with negative (-) cable connected, the resulting sparks can cause a battery explosion, which could result in death or serious injury. (00068a)

▲ WARNING

Disconnect negative (-) battery cable first. If positive (+) cable should contact ground with negative (-) cable connected, the resulting sparks can cause a battery explosion, which could result in death or serious injury. (00049a)

NOTICE

Do not reverse the charger connections described in the following steps or the charging system of the motorcycle could be damaged. (00214a)

3. Connect the red battery charger lead to positive (+) terminal of the battery.
4. Connect the black battery charger lead to negative (-) terminal of the battery.

NOTE

If the battery is still in the vehicle, connect the negative lead to the chassis ground. Make sure that the ignition and all electrical accessories are turned off.

5. Step away from the battery and turn on the charger.

▲ WARNING

Unplug or turn OFF battery charger before disconnecting charger cables from battery. Disconnecting clamps with charger ON can cause a spark and battery explosion, which could result in death or serious injury. (00067a)

6. After the battery is fully charged, turn OFF the charger and disconnect the black battery charger lead to the negative (-) terminal of the battery.
7. Disconnect the red battery charger lead to the positive (+) terminal of the battery.
8. Mark the charging date on the battery.

Table 40. 28 Amp-Hour Battery Charging Rate/Times (Approximate)

READING (VOLTS)	PERCENT OF CHARGE	5 AMP CHARGER	2 AMP CHARGER	1.5 AMP CHARGER	0.75 AMP CHARGER
12.7	100	-	-	-	-
12.6	75	2 hours 24 minutes	4 hours 30 minutes	5 hours 42 minutes	10 hours 18 minutes
12.3	50	3 hours 48 minutes	8 hours	10 hours 18 minutes	19 hours 42 minutes
12.0	25	5 hours 12 minutes	11 hours 30 minutes	15 hours	29 hours
11.8	0	6 hours 36 minutes	15 hours	19 hours 42 minutes	38 hours 18 minutes

Storage

If the motorcycle will not be operated for several months, such as during the winter season, remove the battery from the motorcycle and fully charge.

If the motorcycle is to be stored with the battery installed, it will be necessary to connect a battery tender to maintain charge. See an authorized dealer for more information.

A battery that is removed from the vehicle is affected by self-discharge. A battery that is stored in the vehicle is affected by both self-discharge and, more significantly, parasitic loads. Parasitic loads occur from things like diode leakage and maintaining computer memory with the vehicle off.

- Batteries self-discharge at a faster rate at higher ambient temperatures.

- To reduce the self-discharge rate, store battery in a cool, dry place.
- Charge the battery once per month if stored in the vehicle.
- Charge the battery every three months if stored out of the vehicle.

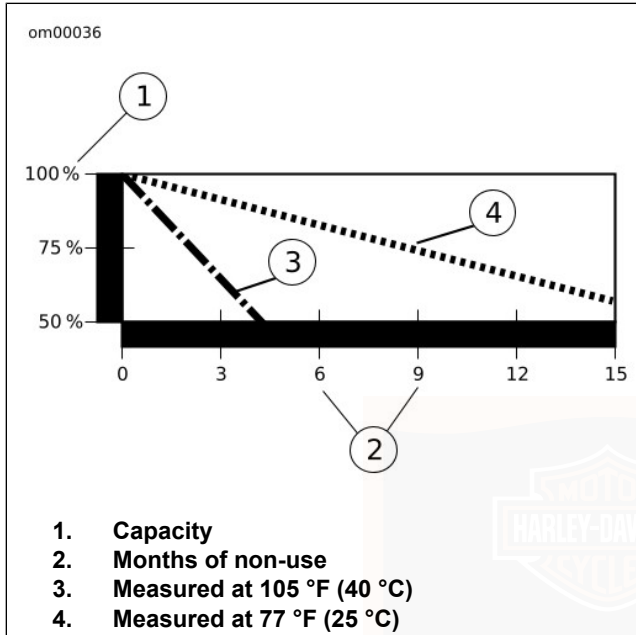

Figure 70. Effective Rate of Temperature on Battery Self-discharging Rate

BATTERY

Disconnection and Removal

1. Remove seat.
2. See Figure 71. If present, move purge solenoid (1) forward to release from top caddy. Release HFSM antenna (2) from top caddy and move out of the way.
3. Remove fasteners (4).
4. Cut cable ties (3) and move harnesses to allow more clearance for the top caddy.
5. See Figure 72. Release top caddy from front hold-down bracket and rotate top caddy (1) out of the way.
6. If equipped with security system siren, turn the ignition switch ON with the hands-free fob present to disarm the security system.

▲ WARNING

Disconnect negative (-) battery cable first. If positive (+) cable should contact ground with negative (-) cable connected, the resulting sparks can cause a battery explosion, which could result in death or serious injury. (00049a)

7. Remove battery negative cable (black) from the battery negative (-) terminal.
8. Remove battery positive cable (red) from the battery positive (+) terminal.
9. Grasp lifting strap (2) and pull up to raise battery. When battery is extracted far enough to get a good grip, grasp battery and remove the rest of the way.

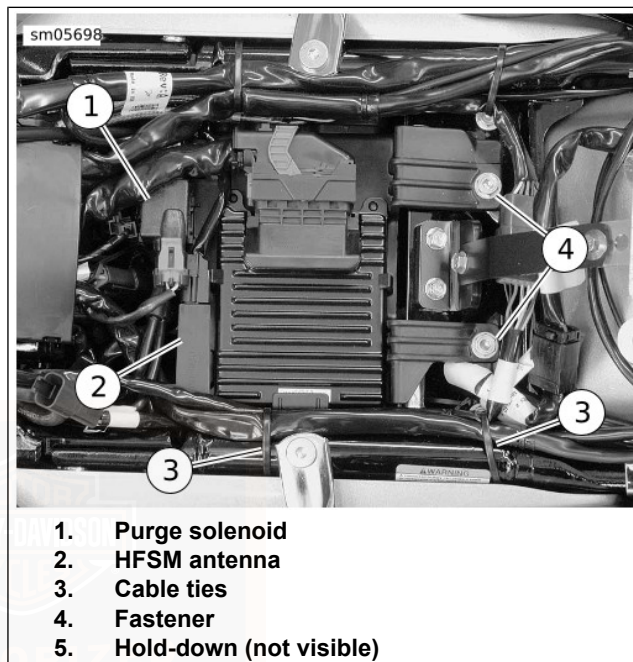

Figure 71. Top Caddy

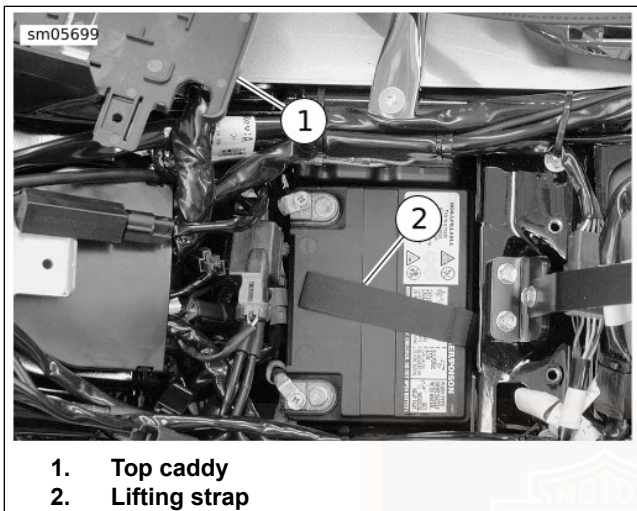

Figure 72. Move Top Caddy Aside

Installation and Connection

1. Run lifting strap rearward, first down the center of the battery tray, then up and across the frame crossmember.
2. Place the battery into the battery tray, terminal side forward.

NOTICE

Connect the cables to the correct battery terminals. Failure to do so could result in damage to the motorcycle electrical system. (00215a)

⚠ WARNING

Connect positive (+) battery cable first. If positive (+) cable should contact ground with negative (-) cable connected, the resulting sparks can cause a battery explosion, which could result in death or serious injury. (00068a)

NOTICE

Do not over-tighten bolts on battery terminals. Use recommended torque values. Over-tightening battery terminal bolts could result in damage to battery terminals. (00216a)

3. Connect battery positive cable (red) to battery positive (+) terminal. Tighten bolt to 6.8–7.9 N·m (60–70 **in-lbs**).
4. Connect battery negative cable (black) to battery negative (-) terminal. Tighten bolt to 6.8–7.9 N·m (60–70 **in-lbs**).

NOTICE

Keep battery clean and lightly coat terminals with petroleum jelly to prevent corrosion. Failure to do so could result in damage to battery terminals. (00217a)

5. Apply a light coat of petroleum jelly or ELECTRICAL CONTACT LUBRICANT, Part No. 99861-02 (1 oz tube), to both battery terminals.
6. See Figure 72. Fold lifting strap (2) forward over top of battery.
7. See Figure 71. Rotate top caddy into position above battery and engage latch on hold-down bracket.
8. If equipped, engage HFMS antenna (2) and purge solenoid (1) on top caddy. Verify all other connectors and harnesses are routed below the purge solenoid mounting tongue.
9. Fasten top caddy to frame crossmember. Tighten screws (4) to 8.1–10.9 N·m (72–96 **in-lbs**).
10. Secure harnesses to frame with cable ties (3).

⚠ WARNING

After installing seat, pull upward on seat to be sure it is locked in position. While riding, a loose seat can shift causing loss of control, which could result in death or serious injury. (00070b)

11. Install seat.

JUMP STARTING

Jump-starting a motorcycle is typically not recommended. However, there may be circumstances when it is necessary to do so. If a jump-start is necessary, use the following procedure.

⚠ WARNING

Be sure jumper cables touch only appropriate battery terminals or ground. Allowing jumper cables to touch each other can result in sparks and a battery explosion, which could result in death or serious injury. (00072a)

⚠ WARNING

Explosive hydrogen gas, which escapes during charging, could cause death or serious injury. Charge battery in a well-ventilated area. Keep open flames, electrical sparks and smoking materials away from battery at all times. KEEP BATTERIES AWAY FROM CHILDREN. (00065a)

NOTICE

Be sure both vehicles have the same battery voltage when jump starting. Connecting vehicles with different system voltages can result in vehicle damage. (00220c)

NOTE

- This procedure presumes the BOOSTER battery is in another vehicle. DO NOT jump start from a running booster vehicle. The high output charging systems on some vehicles can damage the electrical components on the motorcycle.*
- Make sure the motorcycle and the BOOSTER vehicle are not touching one another.*

1. Turn off all unnecessary lamps and accessories.

Positive Cable

1. See Figure 73. Connect one end of a jumper cable to the DISCHARGED battery positive (+) terminal (1).

2. Connect the other end of the same cable to the BOOSTER battery positive (+) terminal (2).

Negative Cable

⚠ WARNING

Do not connect negative (-) cable to or near the discharged battery negative (-) terminal. Doing so could cause a spark and explosion, which could result in death or serious injury. (00073a)

1. Connect one end of a jumper cable to the BOOSTER battery negative (-) terminal (3).

NOTICE

Do not connect the negative (-) cable to painted or chrome parts. Doing so could result in discoloration at the attachment point. (00221a)

2. Connect other end of the same cable (4) to a safe ground, (away from the DISCHARGED battery).
3. Start motorcycle.
4. Disconnect cables in reverse order of Steps 2, 3, 4, 5; that is: Steps 5, 4, 3, 2.

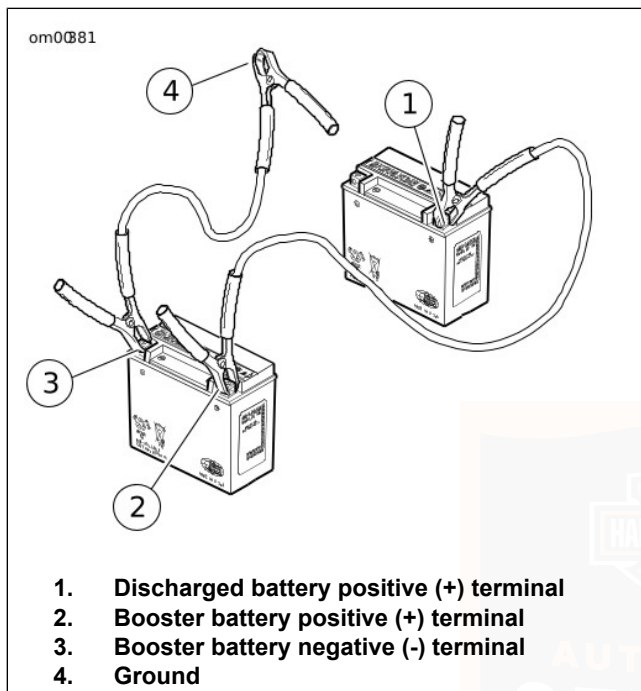

Figure 73. Jump Start Cable Connections

FUSES AND RELAYS

Main Fuse

See Figure 74. A 40 amp main fuse (2) is located near the fuse block. Removing the main fuse will disconnect power to all systems except the starter motor/solenoid.

If equipped with security system siren, turn the ignition switch ON with the hands-free fob present to disarm the security system before removing the main fuse.

System Fuses

NOTICE

Do not skip any steps for fuse replacement. Skipping fuse replacement steps can result in damage to the sound system and/or other motorcycle systems. (00223a)

See Figure 74. Fuses are located under left side cover.

If fuse replacement does not correct a problem, see a Harley-Davidson dealer for electrical diagnosis.

1. Place the ignition/headlamp key switch in the OFF position.

NOTE

Removal of side cover requires no tools. Pull side cover to remove. To install, align barbed studs on side cover with grommets in frame and push.

2. Remove left side cover.
3. See Figure 74. Press latch on bottom of fuse block cover (1) and swing bottom of the cover out. Remove the cover.

NOTE

The fuse block cover has a fuse puller (3) attachment that may be used to remove fuses.

4. See Figure 75. Remove fuse and inspect the element.

NOTICE

Always use replacement fuses that are of the correct type and amperage rating. Use of incorrect fuses can result in damage to electrical systems. (00222a)

5. Replace the fuse if the element is burned or damaged.

NOTE

Use automotive-type ATO fuses for replacements. Two spare fuses can be found in the fuse block.

6. Install the fuse block cover.
7. Install left side cover.

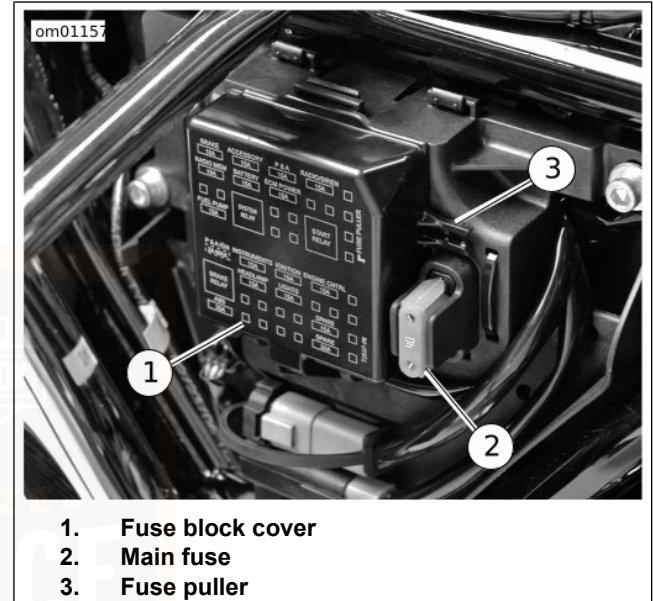
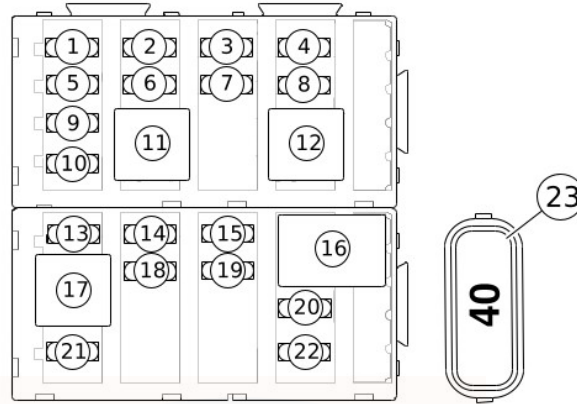

Figure 74. Fuse Block Area

om01155b



- | | |
|--------------------------------------|----------------------------|
| 1. Brake (15 A) | 13. P&A ignition (2 A max) |
| 2. Accessory (15 A) | 14. Instruments (15 A) |
| 3. P&A (15 A) | 15. Ignition (15 A) |
| 4. Radio power (15 A) | 16. Lighting relay |
| 5. Radio memory (15 A) | 17. Brake relay |
| 6. Battery (15 A) | 18. Headlamp (15 A) |
| 7. ECM power (15 A) | 19. Lights (15 A) |
| 8. Power outlet (15 A) (if equipped) | 20. Spare (15 A) |
| 9. Exhaust control (15 A) | 21. ABS (30 A) |
| 10. Fuel pump (15 A) | 22. Spare (30 A) |
| 11. System relay | 23. Main fuse (40 A) |
| 12. Start relay | |

Figure 75. Fuses

SEAT

Removal

1. Open Tour-Pak (if equipped) to move passenger backrest out of the way. See CONTROLS AND INDICATORS > TOUR-PAK (Page 65).

NOTE

The Tour-Pak must be positioned to the rear to gain access to the seat mounting bracket screw. If the Tour-Pak is in the forward position, remove Tour-Pak and temporarily install in rearward position.

2. Remove the left side saddlebag.

NOTICE

Detach passenger seat strap before removing seat. Failure to do so can result in damage to rear fender paint. (00225a)

3. See Figure 76. Remove fastener from seat strap bracket.
4. Pull upward on strap to free it from slot in bracket.
5. See Figure 77. On FLHRC, carefully pull passenger seat strap through slots in the seat to remove.

6. Place seat strap on right side of vehicle.
7. To protect finish of Tour-Pak, cover rear seat mounting bracket with palm of hand.
8. See Figure 78. While pushing seat forward, raise rear of seat until bracket clears top of Tour-Pak (if equipped). Push seat rearward slightly to free tongue from slot in seat.
9. Remove seat from frame.

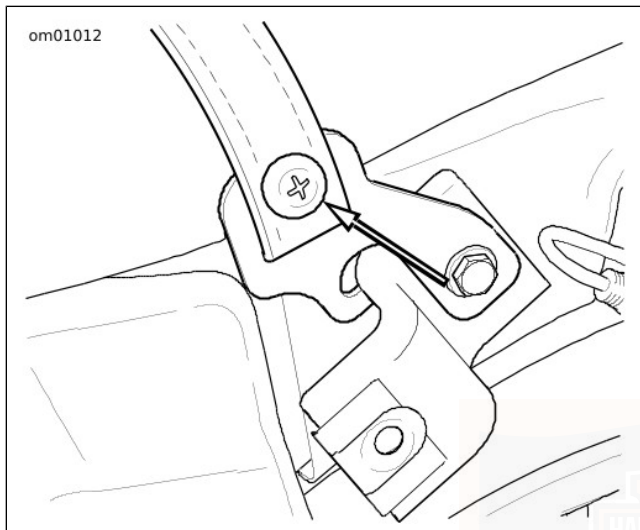

Figure 76. Seat Strap Bracket Screw (typical)



Figure 77. Strap Slots: FLHRC

Installation

1. See Figure 79. Place seat on frame backbone.
2. To protect finish of Tour-Pak, cover rear seat mounting bracket with palm of hand.

3. See Figure 78. While raising rear of seat approximately 76.2 mm (3 in), use other hand to firmly push downward and rearward until tongue engages slot in seat.
4. Push seat forward. Align mounting bracket with seat retention nut on rear fender.
5. Install fastener to secure seat to rear fender. Tighten to 2.3–4.5 N·m (20–40 **in-lbs**).
8. Pull up on seat to verify that it is properly secured.
9. Install saddlebag.
10. If moved, install Tour-Pak in its original location.

NOTE

If the seat retention nut is damaged or lost, see service manual for instructions.

6. See Figure 77. On FLHRC, carefully route free end of passenger seat strap through slots in the seat.
7. See Figure 76. Install end of seat strap in the bracket slot. Install seat strap bracket fastener. Tighten to 5.4–8.1 N·m (48–72 **in-lbs**).

▲ WARNING

After installing seat, pull upward on seat to be sure it is locked in position. While riding, a loose seat can shift causing loss of control, which could result in death or serious injury. (00070b)



Figure 78. Seat Tongue

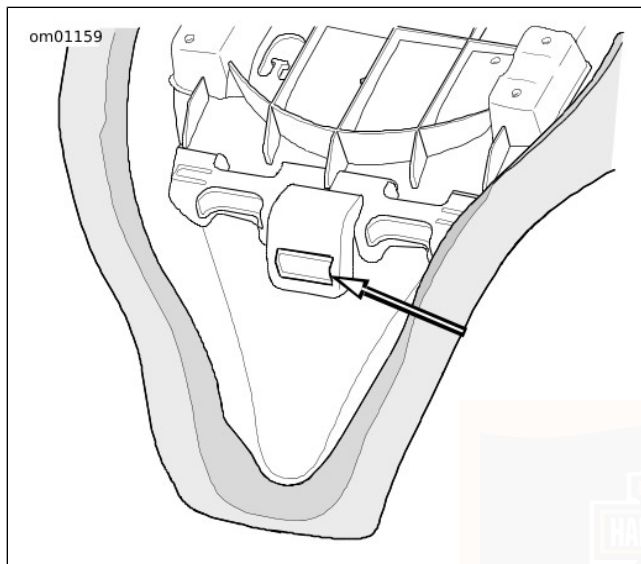

Figure 79. Seat Mounting Slot

MOTORCYCLE STORAGE

Placing Motorcycle in Storage

NOTICE

Proper storage is important for the trouble-free operation of your motorcycle. See your Owner's Manual for storage recommendations or see a Harley-Davidson dealer. Improper storage procedures can lead to equipment damage. (00046a)

If the motorcycle will not be operated for several months, such as during the winter season, there are several tasks which should be performed. These steps will protect parts against corrosion, preserve the battery and prevent the build-up of gum and varnish in the fuel system.

▲ WARNING

Do not store motorcycle with gasoline in tank within the home or garage where open flames, pilot lights, sparks or electric motors are present. Gasoline is extremely flammable and highly explosive, which could result in death or serious injury. (00003a)

NOTE

Make a list of everything you do and fasten it to a handgrip. When you take the motorcycle out of storage, this list will be

your reference/checklist to get your motorcycle in operating condition.

1. Fill fuel tank and add a gasoline stabilizer. Use one of the commercially available gasoline stabilizers and follow the manufacturer's instructions.
2. Warm motorcycle to operating temperature. Change oil and turn engine over to circulate the new oil.
3. Check and adjust belt if necessary.
4. Check tire inflation. Adjust to proper inflation pressure.
5. To protect the vehicle's body panels, engine, chassis and wheels from corrosion, follow the cosmetic care procedures described in the OWNER MANUAL > CARE AND CLEANING (Page 201) section of this owner's manual prior to storage.
6. Prepare battery for winter storage. See MAINTENANCE AND LUBRICATION > BATTERY: GENERAL (Page 178).

NOTE

- *If the motorcycle will be stored with the security system armed, connect a Battery Tender to maintain battery charge.*

- *If the motorcycle will be stored with the security system disarmed, turn ignition switch to ON while the hands-free fob is present. This will prevent the optional siren from sounding. Disconnect the negative battery cable and prepare battery for storage. See MAINTENANCE AND LUBRICATION > BATTERY: GENERAL (Page 178).*

▲ WARNING

Explosive hydrogen gas, which escapes during charging, could cause death or serious injury. Charge battery in a well-ventilated area. Keep open flames, electrical sparks and smoking materials away from battery at all times. KEEP BATTERIES AWAY FROM CHILDREN. (00065a)

7. If motorcycle is to be covered, use a material such as light canvas that will breathe. Plastic materials that do not breathe promote the formation of condensation.

Removing Motorcycle From Storage

⚠ WARNING

The clutch failing to disengage can cause loss of control, which could result in death or serious injury. Prior to starting after extended periods of storage, place transmission in gear and push vehicle back and forth several times to assure proper clutch disengagement. (00075a)

1. See MAINTENANCE AND LUBRICATION > BATTERY: GENERAL (Page 178) for proper battery care. Charge and install the battery.
2. Remove and inspect the spark plugs. Replace if necessary.
3. Clean the air cleaner element.
4. Start the engine and run until it reaches normal operating temperature. Turn off engine.
5. Check amount of oil in the oil tank.
6. Check the transmission lubricant level.

7. Check controls to be sure they are operating properly. Operate the front and rear brakes, throttle, clutch and shifter.
8. Check steering for smoothness by turning the handlebars through the full operating range.

⚠ WARNING

Be sure tires are properly inflated, balanced, undamaged, and have adequate tread. Inspect your tires regularly and see a Harley-Davidson dealer for replacements. Riding with excessively worn, unbalanced, improperly inflated, overloaded or damaged tires can lead to tire failure and adversely affect stability and handling, which could result in death or serious injury. (00014b)

9. Check tire pressure. Incorrect pressure will result in poor riding characteristics and can affect handling and stability.
10. Check all electrical equipment and switches including the stop lamp, turn signals and horn for proper operation.
11. Check for any fuel, oil or brake fluid leaks.

NOTICE

Turn engine over a few times to be sure there is no oil in the crankcase and that all oil has been pumped back into the oil tank. Stop engine and re-check oil level. Failure to do so can result in engine damage. (00071a)



NOTES



CLEANING AND GENERAL CARE

Clean and protect the cosmetic surfaces on your motorcycle as often as possible to inhibit rust and corrosion. After the motorcycle is cleaned, polish and seal the motorcycle to create a sacrificial barrier of protection against the weather and harsh substances.

Refer to Table 41 and Table 42. Harley-Davidson cleaning products are tested extensively for use on vehicle surfaces and are formulated to be compatible with one another. See a Harley-Davidson dealer to purchase recommended cleaning products.

NOTE

Use recommended surface care products. Paper towels, terry cloths, cloth diapers or other materials with nylon fibers can create fine scratches to surfaces.

⚠ WARNING

Observe warnings on labels of cleaning compounds. Failure to follow warnings could result in death or serious injury. (00076a)

⚠ WARNING

Do not wash brake discs with cleaners containing chlorine or silicone. Cleaners containing chlorine and silicone can impair brake function, which could result in death or serious injury. (00077a)

NOTICE

Do not use a pressure washer to clean motorcycle. Using a pressure washer can result in equipment damage. (00489c)

NOTICE

Use of abrasive products or powered buffing equipment will cause permanent cosmetic damage to body panels. Use only recommended products and techniques outlined in this manual to avoid damaging body panels. (00245b)

SERVICES

Table 41. Recommended Cleaning and Care Products

PRODUCT	PART NUMBER	PURPOSE	FRAME	BODY PANELS	WHEELS	DENIM FINISH	OTHER	
H-D Sunwash Cleaner Concentrate	94659-98	General cleaning and washing of all surfaces. Prevents hard water spots and rinses clean in the sun.	Yes	Yes	Yes	Yes		
H-D Bug Remover	94657-98	Removes bugs from metal, plastic or painted surfaces.	Yes	Yes	Yes	Yes		
Harley-Gloss	94627-98	Produces high gloss with UV protection. Allows chrome to breathe, unlike wax. Good for windshields.	Yes	Yes	Yes	Yes		
Harley Spray Cleaner and Polish	99817-99A	Aerosol spot cleaner and detailer. Degreases and reduces static attraction to dust.	Yes	Yes	Yes	No		
Wheel and Tire Cleaner	94658-98	Cleans wheels, tires, whitewalls and black-coated exhaust pipes and mufflers. Do not use on frames or anodized parts.	No	No	Yes	No		
Harley Bright Chrome Cleaner	94683-99	Shines chrome-plated surfaces and cleans brushed aluminum or stainless steel surfaces.	As applicable					
Harley Bright Metal Polish	99725-89	Polishes non-clear coated polished aluminum or polished stainless steel surfaces.	As applicable					

Table 41. Recommended Cleaning and Care Products

PRODUCT	PART NUMBER	PURPOSE	FRAME	BODY PANELS	WHEELS	DENIM FINISH	OTHER	
Harley Glaze Polish & Sealant	99701-84	Polishes windshields, painted surfaces and chrome.	Yes	Yes	As applicable	No		
H-D Swirl & Scratch Treatment	94655-98	Removes fine scratches and swirls.	Yes	Yes	No	No		
H-D Spray Cleaner & Polish	99817-99A	Waterless quick cleaner and detailer.	Yes	Yes	Yes	No		
H-D Black Tire Sidewall Protectant	94628-05	Restores luster to black tire sidewalls.	No	No	No	No	Tires	
H-D Preserve Bare Aluminum Protectant	99845-07	Corrosion control for bare aluminum surfaces.	As applicable					
H-D Windshield Water Repellent Treatment	99841-01	Allows water to bead and dissipate from the windshield.	No	No	No	No	Windshield	
H-D Leather Dressing	98261-91V	Weatherproofs and preserves leather products.	No	No	No	No	Leather goods	
S100 Total Cycle Cleaner	99760-85T	Cleans painted surfaces, chrome and aluminum. Rinse completely while surfaces are wet. Do not allow to dry.	Yes	Yes	Yes	No		
Grease-cutting dishwashing detergent	Not applicable	Cleans Denim finish. Dilute per manufacturer's instructions.	No	No	No	Yes		
Ammonia-based glass cleaner	Not applicable	Spot cleans Denim finish. Do NOT use on windshields.	No	No	No	Yes		

Table 41. Recommended Cleaning and Care Products

PRODUCT	PART NUMBER	PURPOSE	FRAME	BODY PANELS	WHEELS	DENIM FINISH	OTHER
NOVUS 1 Cleaner/Protectant	99837-94T	Cleans windshields, tail lamps and all plastics. Resists fingerprints, fogging, smears and repels dust.	No	No	No	No	Windshield
NOVUS 2 Scratch Remover	99836-94T	Minor scratch remover for windshields and plastics. Apply after NOVUS 1.	No	No	No	No	Windshield

Table 42. Recommended Surface Care Products

PRODUCT	PART NO.	DESCRIPTION
Wash Mitt	94760-99	Absorbant wool-blended washing mitten.
Soft Detailing Pad	94790-01	Soft pad for removing bugs and debris without scratching the surface finish.
Softstrips	94680-99	For cylindrical surfaces such as handlebars, forks, pushrod covers and spokes.
Softcloth	94656-98	Non-absorbant cloth for applying and buffing Swirl & Scratch treatment and Harley Glaze to painted surfaces or chrome.
Soft Drying Towel	94791-01	Extra-absorbant, non-streaking synthetic towel for drying. Dampen towel and wring out before using for greatest absorbancy.
Wheel & Spoke Brush	43078-99	Cone-shaped scrub brush for wheels.
Microfiber Detailing cloth	94663-02	Highly absorbant detailing cloth for polishing and sealing. Contains no nylon fibers.
S100 Detailing Swabs	99780-04	Large cotton swabs for cleaning crevices and detailed surfaces.

WASHING THE MOTORCYCLE

Refer to Table 41 and Table 42 for recommended cleaning and care products.

Preparation

1. Allow motorcycle to cool before rinsing or washing. Spraying water on hot surfaces can leave water spots and mineral deposits.
2. Rinse the motorcycle from the bottom up.
3. To loosen dried bugs or hardened dirt, allow surfaces to soak under a damp towel.

Cleaning the Wheels and Tires

1. Rinse wheel and tire surfaces. Avoid splashing brake dust on chrome or painted parts.
2. Apply Wheel and Tire Cleaner. Allow cleaner to sit for 1 minute.
3. Clean wheel with Soft Detailing Pad or Wheel & Spoke Brush. Use Softstrips to clean wheel spokes.
4. Rinse well.

Washing the Motorcycle

NOTE

Refer to the appropriate instructions in this section for cleaning leather, Denim (flat) finishes, windshields or other special surfaces.

1. Fill a bucket with clean water.
2. Fill another bucket with water and add H-D Sunwash Cleaner Concentrate, following the directions on the package.
3. Soak the H-D Wash Mitt in the Sunwash solution. Wash all surfaces from the top working down.
4. Use H-D Bug Remover to remove any bugs.
5. Rinse from the bottom up, then rinse from the top down.

Drying the Motorcycle

1. Dry the surfaces of the motorcycle from the top down using a Soft Drying Towel or HOG Blaster.
2. Dampen towel in clean water and wring out the excess. The towel is more absorbent when wet.
3. Wipe across the vehicle surface.
4. Repeat as necessary until surface is completely dry.

Polishing and Sealing

NOTE

If motorcycle has Denim finish, skip the Polishing and Sealing procedure.

1. Apply Harley Glaze Polish & Sealant with a Softcloth or Microfiber Detailing Cloth, following the instructions on the package.
2. Buff with a Softcloth.

Finishing Tires

1. Apply Harley Black to tires, following the instructions on the package.

DENIM FINISH CARE

Some motorcycles have a Denim (flat or matte) finish. The Denim finish has qualities which differ from high gloss finishes on all other Harley-Davidson motorcycles. Like denim fabric, Denim paint will burnish or mar with age and use, thus adding character and personality to the finish of the motorcycle. Refer to Table 41 for recommended products.

- If scratched, the color coat of paint does nick/scuff and these marks cannot be rubbed out.
- If polished, the finish will become less matte and more glossy over time.

How to Clean

1. For heavier deposits:
 - a. Use grease cutting dishwashing detergent and a clean Wash Mitt. (Dilute the detergent per the instruction provided by its manufacturer.)
 - b. Rinse thoroughly with clean water.
2. For light deposits, use glass cleaner (ammonia base) and Softcloth. This helps remove finger prints and light soil.
3. For final detailing, apply Harley Gloss with a Softcloth.

LEATHER CARE

NOTE

Many Harley-Davidson accessories and seats are made of either treated or untreated leather or have leather inserts. Natural materials age differently and require different care than man-made materials. Seat covers and panels made of leather will gain "character", such as wrinkles, with age. Leather is porous and organic and each leather product will settle into its own distinct form with use. Your leather product will mature into its own custom shape and style from the sun, rain and time. This maturing is natural and will enhance the custom quality of your Harley-Davidson motorcycle.

Leather surfaces are not designed for long-term exposure to inclement weather and should be protected with a

Harley-Davidson Seat Rain Cover or Motorcycle Storage Cover (sold separately). See your Harley-Davidson dealer.

Leather must be periodically cleaned and treated to maintain its appearance and extend its life. Clean and treat leather once a season or more frequently under adverse conditions.

NOTICE

Do not use bleach or detergents containing bleach on saddlebags, seats, tank panels or painted surfaces. Doing so can result in equipment damage. (00229a)

- Do not use ordinary soap to clean leather or fur. It could dry or remove the oils from the leather.
 - Use ONLY a good quality saddle soap to clean leather. Be sure you rinse saddle soap off thoroughly before treating leather.
 - Never try to dry leather quickly, using artificial means. Always let leather dry naturally, at room temperature. Always allow leather to dry completely before using.
1. Vacuum or blow dust off.
 2. Thoroughly clean leather with a good quality saddle soap, following manufacturer's directions. Rinse thoroughly with clean sponge or cloth and water. Allow leather to dry.

3. Once leather is dry, treat with a good quality leather treatment, such as H-D Leather Dressing.

WHEEL CARE

Regular washing and the use of a corrosion protectant will help the wheels maintain their original appearance. Damage from harsh chemicals, acid based wheel cleaners, brake dust and lack of maintenance can occur. Refer to Table 41 for recommended cleaning products.

NOTE

- *It is imperative that the wheels are cared for weekly to guard against pitting and corrosion.*
- *Corrosion of these components is not considered to be a defect in materials or workmanship.*
- *Aluminum wheels do not have a protective coating.*

WHITEWALL TIRES

Use a good quality, commercial whitewall cleaner and follow the manufacturer's directions.

WINDSHIELD CARE

NOTICE

Polycarbonate windshields/wind deflectors require proper attention and care to maintain. Failure to maintain polycarbonate properly can result in damage to the windshield/wind deflector. (00483e)

- Do not clean in hot sun or high temperature.
- Powdered, abrasive or alkaline cleanser will damage the windscreen/windshield.

NOTICE

Use only Harley-Davidson recommended products on Harley-Davidson windshields. Do not use harsh chemicals or rain sheeting products, which can cause windshield surface damage, such as dulling or hazing. (00231c)

Windshields require special care. Harley-Davidson recommends using Harley Softcloths to clean your windshield. Refer to Table 35 for recommended cleaning products.

NOTE

- *Use NOVUS 2 SCRATCH REMOVER to remove minor scratches.*
- *To treat the windshield with water repellent use WINDSHIELD WATER REPELLENT TREATMENT.*
- *Covering the windshield with a clean, wet cloth for approximately 15-20 minutes before washing will make dried bug removal easier.*

1. Use mild soap and warm water to wash the windshield.
2. Wipe dry with a clean Soft Drying Towel.

NOTE

To minimize swirl marks, cleaning should be done when motorcycle is cool and parked in the shade. Faint swirl marks are normal and may be more visible on tinted windshields.

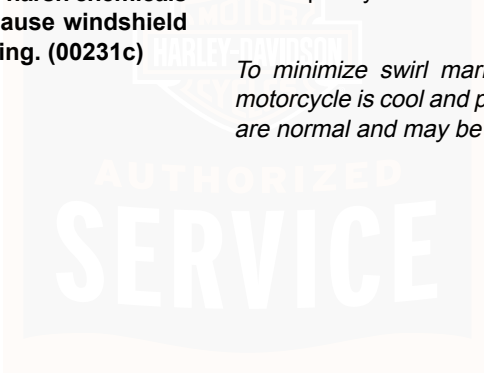

TROUBLESHOOTING: GENERAL

⚠ WARNING

The troubleshooting section of the Owner's Manual is a guide to diagnose problems. Read the service manual before performing any work. Improper repair and/or maintenance could result in death or serious injury. (00080a)

The following checklist of possible operating troubles and their probable causes will be helpful in keeping your motorcycle in good operating condition. More than one of these conditions may be causing trouble and should be carefully checked.

ENGINE: TOURING MODELS

Starter Does Not Operate or Does Not Turn Engine Over

1. Engine OFF/RUN switch in OFF position.
2. Ignition switch not ON.
3. Discharged battery or loose or corroded connections (solenoid chatters).
4. Clutch lever not squeezed against handlebar or transmission not in neutral.

5. Jiffy stand not in retracted position (required for international models).
6. Blown fuse.

Engine Turns Over But Does Not Start

1. Fuel tank empty.
2. Fuel filter clogged.
3. Discharged battery or loose or broken battery terminal connections.
4. Fouled spark plugs.
5. Spark plug cable connections loose or in bad condition and shorting.
6. Loose or corroded wire or cable connection(s) at coil or battery.
7. Fuel pump inoperative.
8. Blown fuse.

Starts Hard

1. Spark plugs in bad condition, have improper gap, or are partially fouled.
2. Spark plug cables in bad condition and leaking.
3. Battery nearly discharged.

4. Loose wire or cable connection(s) at one of the battery terminals or at coil.
5. Engine oil too heavy (winter operation).
6. Water or dirt in fuel system.
7. Fuel pump inoperative.

Starts But Runs Irregularly or Misses

1. Spark plugs in bad condition or partially fouled.
2. Spark plug cables in bad condition and leaking.
3. Spark plug gap too close or too wide.
4. Battery nearly discharged.
5. Damaged wire or loose connection at battery terminals or coils.
6. Intermittent short circuit due to damaged wire insulation.
7. Water or dirt in fuel system.
8. Fuel vent system plugged. See dealer.
9. One or more injectors fouled.

A Spark Plug Fouls Repeatedly

1. Fuel mixture too rich.
2. Incorrect spark plug.

Pre-ignition or Detonation (Knocks or Pings)

1. Incorrect fuel.
2. Incorrect spark plug for the kind of service.

Overheats

1. Insufficient oil supply or oil not circulating.
2. Heavy carbon deposit from lugging engine. See dealer.
3. Insufficient air flow over cylinder heads during extended periods of idling or parade duty.

Excessive Vibration

1. Rear fork pivot shaft nuts loose. See dealer.
2. Front engine mounting bolts loose. See dealer.
3. Engine to transmission mounting bolts loose. See dealer.
4. Broken frame. See dealer.
5. Front chain or links tight as a result of insufficient lubrication or belt badly worn.
6. Wheels and/or tires damaged. See dealer.
7. Vehicle not properly aligned. See dealer.

ELECTRICAL SYSTEM

Alternator Does Not Charge

1. Regulator not grounded. See dealer.
2. Engine ground wire loose or damaged. See dealer.
3. Loose or damaged wires in charging circuit. See dealer.

Alternator Charge Rate is Below Normal

1. Weak battery.
2. Excessive use of add-on accessories.
3. Loose or corroded connections.
4. Extensive periods of idling or low speed riding.

TRANSMISSION

Transmission Shifts Hard

1. Bent shifter rod. See dealer.

Transmission Jumps Out of Gear

1. Worn shifter dogs in transmission. See dealer.

Clutch Slips

1. Clutch controls improperly adjusted. See dealer.

2. Worn friction discs. See dealer.
3. Insufficient clutch spring tension. See dealer.

Clutch Drags or Does Not Release

1. Clutch controls improperly adjusted. See dealer.
2. Primary chaincase overfilled.
3. Clutch discs warped. See dealer.

Clutch Chatters

1. Friction discs or steel discs worn or warped. See dealer.

BRAKES

ABS System Behavior

1. ABS lamp does not shut off above 5 km/h (3 mph). See dealer.
2. Other ABS symptoms. Refer to Table 21.

Brakes Do Not Hold Normally

1. Master cylinder low on fluid. See dealer.
2. Brake line contains air bubbles. See dealer.
3. Master or wheel cylinder piston worn. See dealer.
4. Brake pads contaminated with grease or oil. See dealer.

5. Brake pads badly worn. See dealer.
6. Brake disc badly worn or warped. See dealer.
7. Brake fades because of heat build up. Excessive braking or brake pads dragging. See dealer.
8. Brake drags. Insufficient hand lever free play. See dealer.

HEATED HAND GRIPS

1. Engine must be running. Start engine.
2. Turn ignition/key switch off then back on. Start engine and set hand grip heat.
3. Check the P&A fuse.
4. See dealer.



WARRANTY AND MAINTENANCE

This Owner's Manual contains your new motorcycle warranty and an owner's maintenance record.

It is the owner's responsibility to follow the scheduled mileage intervals as specified. All of the specified maintenance services must be performed to keep your warranty valid.

1. Make an appointment with a Harley-Davidson dealer for inspection and service prior to first 1,600 km (1000 mi).
2. Bring this Owner's Manual with you when you visit your dealer to have your motorcycle inspected and serviced.
3. Have the dealer technician sign the maintenance record in the Owner's Manual at the proper mileage interval. The records should be retained by the owner as proof of proper maintenance.
4. Keep receipts covering any parts, service or maintenance performed.

These records should be transferred to each subsequent owner.

▲ WARNING

Harley-Davidson parts and accessories are designed for Harley-Davidson motorcycles. Using non-Harley-Davidson parts or accessories can adversely affect performance, stability or handling, which could result in death or serious injury. (00001b)

Use only Harley-Davidson approved parts and accessories. Use of other manufacturers performance parts may void your warranty. See a Harley-Davidson dealer.

Harley-Davidson dealerships are independently owned and operated and may sell parts and accessories that are not manufactured or approved by Harley-Davidson. Therefore, you should understand that we are not and cannot be responsible for the quality, suitability, or safety of any non-Harley-Davidson part, accessory or design modification, including labor, which may be sold and/or installed by our dealers.

KEEPING IT ALL HARLEY-DAVIDSON

Genuine Harley-Davidson parts are engineered and tested specifically for use on your motorcycle. Insist that your dealer uses only Genuine replacement parts to keep your Harley-Davidson motorcycle and its warranty intact.

NOTE

Installing off-road or competition parts to enhance performance may void all or part of your new motorcycle warranty. See the Harley-Davidson Motorcycle Limited Warranty in this manual or a Harley-Davidson dealer for details.

NOTICE

It is possible to overload the vehicle's charging system by adding too many electrical accessories. If the combined electrical accessories operating at any one time consume more electrical current than the vehicle's charging system can produce, the electrical consumption can discharge the battery and cause damage to the vehicle's electrical system. (00211d)

CALIFORNIA EVAPORATIVE EMISSION CONTROLS: 2010 MODELS

All new 2010 Harley-Davidson motorcycles sold in the State of California are equipped with an evaporative emission control system. This system is designed to meet the CARB regulations in effect at the time of manufacture. A complete CARB emissions warranty statement can be obtained from your dealer.

The system requires a small amount of maintenance. Periodic inspection is required to make sure hoses are properly routed, not kinked or blocked and that all fittings are secure. Mounting hardware should also be checked periodically for tightness.

214 Warranties and Responsibilities

EPA NOISE REGULATIONS IN THE UNITED STATES

EPA noise regulations require that the following statements be included in the Owner's Manual.

EPA Regulations

TAMPERING WITH NOISE CONTROL SYSTEM PROHIBITED: Federal law prohibits the following acts or the causing thereof: (1) The removal or rendering inoperative by any person other than for purposes of maintenance, repair, or replacement of any device or element of design incorporated into any new vehicle for the purpose of noise control prior to its sale or delivery to the ultimate purchaser or while it is in use, or (2) the use of the vehicle after such device or element of design has been removed or rendered inoperative by any person.

AMONG THOSE ACTS PRESUMED TO CONSTITUTE TAMPERING ARE THE FOLLOWING:

1. Replacing the muffler(s) and/or the entire exhaust system with parts not certified to be noise legal for street use.
2. Removing or modifying the muffler internal baffles in any way.
3. Replacing the air intake/cleaner assembly with one not certified to be noise legal for street use.

4. Modifying the air intake/cleaner assembly in such a way as to make the vehicle no longer noise legal for street use.

Harley-Davidson recommends that any and all noise related maintenance be done by an authorized Harley-Davidson dealer using genuine Harley-Davidson parts.

WARRANTY/SERVICE INFORMATION

Any authorized Harley-Davidson dealer is responsible for providing the warranty repair work on your motorcycle. If you have any questions regarding warranty obligations contact your selling dealer.

For normal service work or warranty work under the above conditions, you may obtain the name and location of your nearest U.S. Harley-Davidson dealer by calling 800-490-9635 (toll free), in any state except Alaska and Hawaii. To find dealers worldwide, see www.harley-davidson.com.

NOTE

The number shown above is accessible only with a touch-tone phone.

REPORTING SAFETY DEFECTS IN UNITED STATES

Safety defects must be reported to the National Highway Traffic Safety Administration (NHTSA) and Harley-Davidson.

NHTSA Statement

If you believe that your vehicle has a defect which could cause a crash or could cause injury or death, you should immediately inform the National Highway Traffic Safety Administration (NHTSA) in addition to notifying Harley-Davidson.

If NHTSA receives similar complaints, it may open an investigation, and if it finds that a safety defect exists in a group of vehicles, it may order a recall and remedy campaign. However, NHTSA cannot become involved in individual problems between you, your dealer, or Harley-Davidson.

Refer to Table 43 to contact NHTSA.

Table 43. NHTSA Contacts

ITEM	DATA
Phone	Call the Auto Safety Hot Line toll-free at 888-DASH-2DOT
Mail	U.S. Department of Transportation, National Highway Traffic Safety Administration, Office of Defects Investigation, NVS-210, 400 7th Street S.W., Washington, D.C. 20590
Web site	www.nhtsa.dot.gov

You can also obtain other information about motor vehicle safety from the hot line.

REQUIRED DOCUMENTATION FOR IMPORTED MOTORCYCLES

If a Harley-Davidson is imported into the United States, additional documentation is required to be eligible for the United States Manufacturer's Limited Warranty. A Harley-Davidson dealer can provide a form explaining the requirements.

OWNER CONTACT INFORMATION

If you move from your present address, sell your motorcycle, or purchase a pre-owned Harley-Davidson or Buell motorcycle,

see a Harley-Davidson or Buell dealer to update your owner contact information.

This will provide the Company with an accurate registration (as required by law in some countries), and will allow the Company to notify you in the event of a recall or product program.

Updated owner information must also be on file with the Company when transferring an Extended Service Plan Contract on a pre-owned motorcycle.

When updating your contact information, your dealer will need your vehicle identification number (VIN), odometer mileage, and date of vehicle transfer (if applicable).

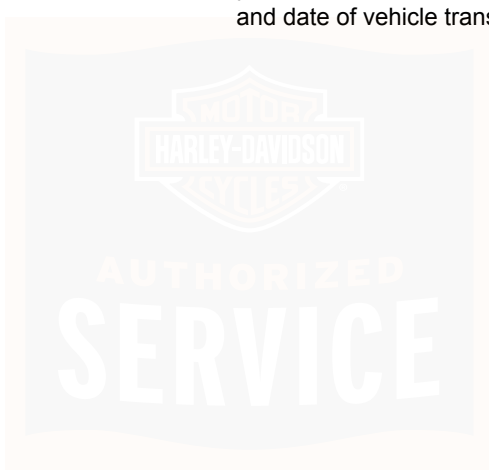

2010 HARLEY-DAVIDSON MOTORCYCLE LIMITED WARRANTY

24 Months/Unlimited Miles

Harley-Davidson warrants for any new 2010 Harley-Davidson motorcycle/sidecar that an authorized Harley-Davidson dealer will repair or replace without charge any parts found under normal use to be defective in factory materials or workmanship. Such repair and replacement will be Harley-Davidson's sole obligation and the customer's sole remedy under this warranty.

THERE IS NO OTHER EXPRESS WARRANTY (OTHER THAN THE SEPARATE EMISSIONS AND NOISE WARRANTIES) ON THE MOTORCYCLE. ANY IMPLIED WARRANTY OF MERCHANTABILITY OR FITNESS FOR PARTICULAR PURPOSE IS LIMITED TO THE DURATION OF THIS WARRANTY.

Some states do not allow limitations on how long an implied warranty lasts, so the above limitation may not apply to you.

TO THE FULLEST EXTENT ALLOWED BY LAW, HARLEY-DAVIDSON AND ITS DEALERS SHALL NOT BE LIABLE FOR LOSS OF TIME, INCONVENIENCE, LOSS OF MOTORCYCLE USE, COMMERCIAL LOSS OR OTHER INCIDENTAL OR CONSEQUENTIAL DAMAGES. Some states do not allow the exclusion or limitation of incidental or consequential damages, so the above limitation or exclusion

may not apply to you. This warranty gives you specific legal rights, and you may have other rights which vary from state to state.

The following terms and conditions apply to this warranty:

Duration

1. The duration of this limited warranty is twenty four months, starting from the earlier of (a) the date of initial retail purchase and delivery from an authorized Harley-Davidson dealer, or (b) the third anniversary of the last day of the model year of the motorcycle/sidecar. Your dealer will submit an electronic Sales and Warranty Registration form to initiate your warranty.
2. Any unexpired portion of this limited warranty will be transferred to subsequent owners, upon the resale of the motorcycle/sidecar during the warranty period.

Owner's Obligations

To obtain warranty service, return your motorcycle/sidecar at your expense within the warranty period to an authorized dealer. Our dealer should be able to provide warranty service during normal business hours and as soon as possible, depending upon the workload of the dealer's service department and the availability of necessary parts.

Harley-Davidson Motor Company, P.O. Box 653, Milwaukee, Wisconsin 53201, U.S.A.

Exclusions

This warranty will not apply to any motorcycle/sidecar as follows:

1. Which has not been operated or maintained as specified in the Owner's Manual.
 2. Which has been abused, misused, improperly stored, used "off the highway," or used for racing or competition of any kind.
 3. Which is not manufactured to comply with the laws of the market in which it is registered.
 4. Installing off-road or competition parts to enhance performance may void all or part of your new motorcycle warranty. See a Harley-Davidson dealer for details.
 5. Acts of God, war, riot, insurrection, natural disasters, including, but not limited to, nuclear contamination, lightning, forest fires, dust storms, hail storms, ice storms, earthquakes, floods, or for other circumstances out of Harley-Davidson's control.
1. Parts and labor for normal maintenance as recommended in the Owner's Manual, or the replacement of parts due to normal wear and tear including such items as the following: tires, lubrication, oil and filter change, fuel system cleaning, battery maintenance, engine tune-up, spark plugs, brake, clutch, chain/belt adjustment and chain replacement.
 2. Cosmetic concerns that arise as a result of owner abuse, lack of proper maintenance or environmental conditions (except concerns that result from defects in material or workmanship, which are covered by this warranty for the duration of the warranty period).
 3. Any cosmetic condition existing at the time of retail delivery that has not been documented by the selling dealer prior to retail delivery.
 4. Defects or damage to the motorcycle caused by alterations outside of Harley-Davidson factory specifications.

Other Limitations

This warranty does not cover:

Important: Read Carefully

1. Our dealers are independently owned and operated and may sell other products. Because of this, HARLEY-DAVIDSON IS NOT RESPONSIBLE FOR THE SAFETY, QUALITY, OR SUITABILITY OF ANY NON-HARLEY-DAVIDSON PART, ACCESSORY OR DESIGN MODIFICATION INCLUDING LABOR WHICH MAY BE SOLD AND/OR INSTALLED BY OUR DEALERS.
2. This limited warranty is a contract between you and the manufacturer. It is separate and apart from any warranty you may receive or purchase from the dealer. The dealer is not authorized to alter, modify, or in any way change the terms and conditions of this warranty.
3. Any warranty work or parts replacement authorized by the manufacturer will not preclude the manufacturer from later relying on any exclusion where applicable.



NOTES



2010 HARLEY-DAVIDSON MOTORCYCLE NOISE CONTROL SYSTEM LIMITED WARRANTY

The following warranty applies to the noise control system, is in addition to the MOTORCYCLE LIMITED WARRANTY and EMISSION CONTROL SYSTEM LIMITED WARRANTY, and applies only to motorcycles sold in the U.S.

Harley-Davidson Motor Company warrants to the first owner and each subsequent owner that this vehicle is designed and built so as to conform at the time of sale with applicable regulations of the U.S. Environmental Protection Agency (as tested following F-76 Drive-By test procedure) and that it is free from defects in materials and workmanship which can cause this motorcycle not to meet U.S. Environmental Protection Agency Standards within one (1) year from initial retail purchase and delivery from an authorized Harley-Davidson dealer or one (1) year from the [second] anniversary of the last day of the model year of the motorcycle, or 6,000 km (3730 mi) whichever occurs first. Any unexpired portion of this limited warranty will be transferred to subsequent owners, upon the resale of the motorcycle during the warranty period. If the motorcycle was used as a demonstrator, then the warranty period may have started and/or expired prior to the initial retail sale. See a Harley-Davidson dealer for details.

THERE IS NO OTHER EXPRESS WARRANTY (OTHER THAN THE SEPARATE MOTORCYCLE AND EMISSIONS WARRANTIES) ON THE MOTORCYCLE. ANY IMPLIED WARRANTY OF MERCHANTABILITY OR FITNESS FOR PARTICULAR PURPOSE IS LIMITED TO THE DURATION OF THIS WARRANTY.

Some states do not allow limitations on how long an implied warranty lasts, so the above limitation may not apply to you.

The Limited 2 year warranty period shall begin on the date the motorcycle is delivered to the first retail purchaser or, if the motorcycle is placed in service as a demonstrator or company vehicle prior to sale at retail, on the date it is first placed in service.

THE FOLLOWING ITEMS ARE NOT COVERED BY THE NOISE CONTROL SYSTEM WARRANTY

1. Failures which arise as a result of misuse, alteration, or non-performance of maintenance as specified in the Owner's Manual.
2. Replacing, removing, or modifying any portion of the NOISE CONTROL SYSTEM (consisting of the exhaust system and air intake/cleaner assembly) with parts not certified to be noise legal for street use.
3. Any motorcycle on which the odometer mileage has been changed so that the mileage cannot be determined.

4. TO THE FULLEST EXTENT ALLOWED BY LAW, HARLEY-DAVIDSON AND ITS DEALERS SHALL NOT BE LIABLE FOR LOSS OF TIME, INCONVENIENCE, LOSS OF MOTORCYCLE USE, COMMERCIAL LOSS OR OTHER INCIDENTAL OR CONSEQUENTIAL DAMAGES.

Some states do not allow the exclusion or limitation of incidental or consequential damages, so the above limitation or exclusion may not apply to you.

Other Rights

This warranty gives you specific legal rights, and you may have other rights which vary from state to state.

Recommendations for Required Maintenance

It is recommended that any noise system maintenance be performed by an authorized Harley-Davidson dealer using genuine Harley-Davidson replacement parts. The maintenance, replacement or repair of the noise control system may be performed by any other qualified service outlet or individual. Non-genuine parts may be used only if such parts are certified to comply with U.S. Environmental Protection Agency Standards.

Harley-Davidson Motor Company, P.O. Box 653, Milwaukee, Wisconsin 53201, U.S.A.

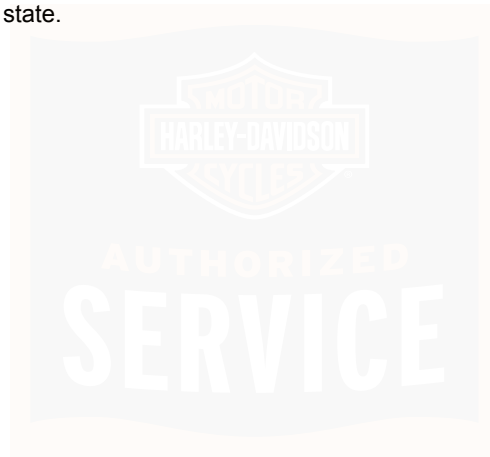

2010 HARLEY-DAVIDSON EMISSION CONTROL SYSTEM LIMITED WARRANTY

The following warranty applies to the emission control system, is in addition to the MOTORCYCLE LIMITED WARRANTY and NOISE CONTROL SYSTEM LIMITED WARRANTY, and applies only to motorcycles sold in the U.S.

Harley-Davidson Motor Company warrants to the first owner and each subsequent owner that this vehicle is designed and built so as to conform at the time of sale with applicable regulations of the U.S. Federal Environmental Protection Agency, and that it is free from defects in materials and workmanship which would cause this motorcycle not to meet U.S. Environmental Protection Agency Standards within five (5) years from initial retail purchased and delivery from an authorized Harley-Davidson dealer or five (5) years from the [second] anniversary of the last day of the model year of the motorcycle, or 30,000 km (18641 mi) whichever occurs first. Any unexpired portion of this limited warranty will be transferred to subsequent owners, upon the resale of the motorcycle during the warranty period. If the motorcycle was used as a demonstrator, then the warranty period may have started and/or expired prior to the initial retail sale. See a Harley-Davidson dealer for details.

THERE IS NO OTHER EXPRESS WARRANTY (OTHER THAN THE SEPARATE MOTORCYCLE AND NOISE WARRANTIES) ON THE MOTORCYCLE. ANY IMPLIED

WARRANTY OF MERCHANTABILITY OR FITNESS FOR PARTICULAR PURPOSE IS LIMITED TO THE DURATION OF THIS WARRANTY.

Some states do not allow limitations on how long an implied warranty lasts, so the above limitation may not apply to you.

The warranty period shall begin on the date the motorcycle is delivered to the first retail purchaser or, if the motorcycle is placed in service as a demonstrator or company vehicle prior to sale at retail, on the date it is first placed in service.

THE FOLLOWING ITEMS ARE NOT COVERED BY THE EMISSION CONTROL SYSTEM WARRANTY

1. Failures which arise as a result of misuse, alterations, accident or non-performance of maintenance as specified in the Owner's Manual.
2. The replacement of parts (such as spark plugs, fuel and oil filters, etc.) used in required maintenance.
3. Any motorcycle on which the odometer mileage has been changed so that the mileage cannot be determined.
4. TO THE FULLEST EXTENT ALLOWED BY LAW, HARLEY-DAVIDSON AND ITS DEALERS SHALL NOT BE LIABLE FOR LOSS OF TIME, INCONVENIENCE, LOSS OF MOTORCYCLE USE, COMMERCIAL LOSS OR OTHER INCIDENTAL OR CONSEQUENTIAL DAMAGES.

Some states do not allow the exclusion or limitation of incidental or consequential damages, so the above limitation or exclusion may not apply to you.

Other Rights

This warranty gives you specific legal rights, and you may have other rights which vary from state to state.

Recommendations for Required Maintenance

It is recommended that any emission system maintenance be performed by an authorized Harley-Davidson dealer using

genuine Harley-Davidson replacement parts. The maintenance, replacement or repair of the emissions control system may be performed by any other qualified service outlet or individual. Non-genuine parts may be used only if such parts are certified to comply with U.S. Environmental Protection Agency Standards.

Harley-Davidson Motor Company, P.O. Box 653, Milwaukee, Wisconsin 53201, U.S.A.



2010 LIMITED RADIO WARRANTY

Harley-Davidson Motor Company warrants that this Harley-Davidson radio will be free from factory defects in material and workmanship, under normal use and service, for a period of twenty four (24) months starting from the earlier of (a) the date of initial retail purchase of the motorcycle/sidecar on which the radio is installed, or (b) the third anniversary of the last day of the model year of the motorcycle/sidecar on which the radio is installed. Any unexpired portion of this limited warranty will be transferred to subsequent owners, upon the resale of the motorcycle during the warranty period. If the motorcycle/sidecar was used as a demonstrator, then the warranty period may have started and/or expired prior to the initial retail sale. See a Harley-Davidson Dealer for details.

This warranty does not cover defects or damage due to abuse, misuse or improper installation, or any radio on a motorcycle which has been registered with Harley-Davidson Motor Company as a collector's vehicle. See a Harley-Davidson dealer for details.

To obtain warranty service, return your motorcycle/sidecar with sound system intact, at your expense, within the warranty period to the selling dealer, or to any other authorized dealer if you have moved a long distance, or are touring a long distance. Our dealer should be able to provide warranty service during his normal business hours and as soon as

possible, depending upon his service department's workload and the availability of necessary parts.

The remedy for breach of this warranty is expressly limited to the repair or replacement, without charge for parts and labor, of any part that proves to be defective, AND DOES NOT EXTEND TO LIABILITY FOR CONSEQUENTIAL DAMAGES, COSTS OR EXPENSES, INCLUDING LOSS OF TIME, INCONVENIENCE OR LOSS OF USE OF THE VEHICLE, RESULTING FROM ANY PART THAT PROVES TO BE DEFECTIVE.

THERE IS NO OTHER EXPRESS WARRANTY ON THE RADIO. ANY IMPLIED WARRANTY RELATING TO THIS RADIO, INCLUDING WARRANTIES OR MERCHANTABILITY OR FITNESS FOR A PARTICULAR PURPOSE, IS EXPRESSLY LIMITED TO TWENTY FOUR (24) MONTHS, THE DURATION OF THIS WARRANTY.

(Some states do not allow the limitation of the length of an implied warranty or the exclusion or limitation of incidental or consequential damages, so the above limitations or exclusions may not apply to you.)

Other Rights

This warranty gives you specific legal rights, and you may have other rights which vary from state to state in the United States.

Harley-Davidson Motor Company, P.O. Box 653, Milwaukee, Wisconsin 53201, U.S.A.



226 Limited Radio Warranty

REGULAR SERVICE INTERVALS

Regular lubrication and maintenance will help keep your new Harley-Davidson operating at peak performance. Your Harley-Davidson dealer knows best how to service your motorcycle with factory approved methods and equipment assuring you of thorough and competent workmanship.

NOTE

- Refer to Table 44. Regular maintenance interval operations are required to keep your new motorcycle warranty in force. The use of other than Harley-Davidson approved parts and service procedures may void the warranty. Any alterations to the emission system components, such as the exhaust system, may be in violation of Federal and State laws.
- Refer to Table 45. When servicing your motorcycle, bring this owner's manual to the dealership and complete information needed in the blank columns listed.

▲ WARNING

Perform the service and maintenance operations as indicated in the regular service interval table. Lack of regular maintenance at the recommended intervals can affect the safe operation of your motorcycle, which could result in death or serious injury. (00010a)

▲ WARNING

If you operate your motorcycle under adverse conditions (severe cold, extreme heat, very dusty environment, very bad roads, through standing water, etc.), you should perform the regular maintenance intervals more frequently to ensure the safe operation of your motorcycle. Failure to maintain your motorcycle could result in death or serious injury. (00094a)

Table 44. Regular Service Intervals: 2010 Touring Models

ITEM SERVICED	PROCEDURE	1000 MI	5000 MI	10000	15000	20000	25000	30000	35000	40000	45000	50000	NOTES
		1600 KM	8000 KM	16000 KM	24000 KM	32000 KM	40000 KM	48000 KM	56000 KM	64000 KM	72000 KM	80000 KM	
Engine oil and filter	Replace	X	X	X	X	X	X	X	X	X	X	X	
Oil lines and brake system	Inspect for leaks, contact or abrasion	X	X	X	X	X	X	X	X	X	X	X	1, 3

Table 44. Regular Service Intervals: 2010 Touring Models

ITEM SERVICED	PROCEDURE	1000 MI 1600 KM	5000 MI 8000 KM	10000 MI 16000 KM	15000 MI 24000 KM	20000 MI 32000 KM	25000 MI 40000 KM	30000 MI 48000 KM	35000 MI 56000 KM	40000 MI 64000 KM	45000 MI 72000 KM	50000 MI 80000 KM	NOTES
Air cleaner	Inspect, service as required	X	X	X	X	X	X	X	X	X	X	X	
Tires	Check pressure, inspect tread	X	X	X	X	X	X	X	X	X	X	X	
Wheel spokes (if equipped)	Check torque	X	X			X			X			X	1, 5
Primary chaincase lubricant	Replace	X		X		X		X		X		X	
Transmission lubricant	Replace	X				X				X			
Clutch	Check adjustment	X	X	X	X	X	X	X	X	X	X	X	1
Drive belt and compensator sprocket	Inspect, adjust belt	X	X	X	X	X	X	X	X	X	X	X	1
Compensator sprocket isolators	Inspect for wear												7
Brake and clutch controls	Check and lubricate	X	X	X	X	X	X	X	X	X	X	X	1
Jiffy stand	Inspect and lubricate	X	X	X	X	X	X	X	X	X	X	X	1
Fuel lines and fittings	Inspect for leaks, contact or abrasion	X	X	X	X	X	X	X	X	X	X	X	1, 3
Fuel tank filter	Replace						X					X	1
Brake fluid	Check levels and condition	X	X	X	X	X	X	X	X	X	X	X	4
Brake pads and discs	Inspect for wear	X	X	X	X	X	X	X	X	X	X	X	
Spark plugs	Inspect	X	X	X	X		X	X	X		X	X	
	Replace					X				X			

Table 44. Regular Service Intervals: 2010 Touring Models

ITEM SERVICED	PROCEDURE	1000 MI 1600 KM	5000 MI 8000 KM	10000 MI 16000 KM	15000 MI 24000 KM	20000 MI 32000 KM	25000 MI 40000 KM	30000 MI 48000 KM	35000 MI 56000 KM	40000 MI 64000 KM	45000 MI 72000 KM	50000 MI 80000 KM	NOTES
Electrical equipment and switches	Check operation	X	X	X	X	X	X	X	X	X	X	X	
Front fork oil	Replace											X	1, 6
Steering head bearings	Lubricate	X		X		X		X		X			
	Adjust						X					X	1, 2
Air suspension	Check pressure, operation and leakage	X	X	X	X	X	X	X	X	X	X	X	1
Windshield bushings (if applicable)	Inspect			X		X		X		X		X	1
Fuel door, Tour-Pak, saddlebags (if equipped)	Lubricate hinges and latches	X	X	X	X	X	X	X	X	X	X	X	
Critical fasteners	Check tightness	X		X		X		X		X		X	1
Battery	Check battery and clean connections												3
Exhaust system	Inspect for leaks, cracks, and loose or missing fasteners or heat shields	X	X	X	X	X	X	X	X	X	X	X	3



Table 44. Regular Service Intervals: 2010 Touring Models

ITEM SERVICED	PROCEDURE	1000 MI 1600 KM	5000 MI 8000 KM	10000 MI 16000 KM	15000 MI 24000 KM	20000 MI 32000 KM	25000 MI 40000 KM	30000 MI 48000 KM	35000 MI 56000 KM	40000 MI 64000 KM	45000 MI 72000 KM	50000 MI 80000 KM	NOTES
Road test	Verify component and system functions	X	X	X	X	X	X	X	X	X	X	X	
NOTES:	<ol style="list-style-type: none"> 1. Should be performed by an authorized Harley-Davidson dealer, unless you have the proper tools, service data and are mechanically qualified. 2. Disassemble, lubricate and inspect every 80,000 km (50000 mi). 3. Perform annually or at specified intervals, whichever comes first. 4. Change D.O.T. 4 brake fluid and flush system every two years. 5. Perform spoke tension check at the 1000, 5000, 20,000 mile services and every 15,000 mile interval thereafter. Not all vehicles are equipped with spoke wheels. Consult appropriate topic in service manual. 6. Replace fork oil and inspect every 80,000 km (50000 mi). 7. Perform at each rear tire change. 												

Table 45. Owner's Maintenance Records

SERVICE MILE INTERVAL	DATE	DEALER NUMBER	TECHNICIAN NAME	TECHNICIAN SIGNATURE
1000 MI (1600 KM)				
5000 MI (8000 KM)				
10,000 MI (16,000 KM)				
15,000 MI (24,000 KM)				
20,000 MI (32,000 KM)				
25,000 MI (40,000 KM)				
30,000 MI (48,000 KM)				
35,000 MI (56,000 KM)				
40,000 MI (64,000 KM)				

Table 45. Owner's Maintenance Records

SERVICE MILE INTERVAL	DATE	DEALER NUMBER	TECHNICIAN NAME	TECHNICIAN SIGNATURE
45,000 MI (72,000 KM)				
50,000 MI (80,000 KM)				

SERVICE LITERATURE

Refer to Table 46. Visit any Harley-Davidson dealer or go to www.harley-davidson.com to purchase a service or parts

manual for your motorcycle. Factory authorized manuals are the most complete and detailed source of information outside of your Harley-Davidson dealer.

Table 46. Service Literature: 2010 Touring Models

DOCUMENT	LANGUAGE	PART NUMBER
Touring Models Service Manual	English	99483-10
Touring Models Electrical Diagnostics Manual	English	99497-10
Touring Models Service and Electrical Diagnostics Manual	French	99483-10FR
Touring Models Service and Electrical Diagnostics Manual	German	99483-10DE
Touring Models Service and Electrical Diagnostics Manual	Spanish	99483-10ES
Touring Models Service and Electrical Diagnostics Manual	Italian	99483-10IT
Touring Models Parts Catalog	English	99456-10
Sidecar Service Manual	English	99485-10

H-D MICHIGAN, INC. TRADEMARK INFORMATION

Harley, Harley-Davidson, H-D, Bar & Shield, Cross Bones, Digital Tech, Digital Technician, Digital Technician II, Dyna, Electra Glide, Evolution, Fat Bob, Fat Boy, Glaze, Gloss, H-D,

H-Dnet.com, HD, Harley, Harley-Davidson, Heritage Softail, Low Rider, Night Rod, Nightster, Night Train, Profile, Revolution, Road Glide, Road King, Road Tech, Rocker, Softail, Sportster, Street Glide, Street Rod, Sun Ray, Sunwash, Tech Link, Twin Cam 88, Twin Cam 88B, Twin Cam 96, Twin Cam 96B, Twin Cam 103, Twin Cam 103B,

Twin Cam 110, Twin Cam 110B, Tour-Pak, Screamin' Eagle, Softail, Super Glide, SYN3, Ultra Classic, V-Rod, VRSC and Harley-Davidson Genuine Motor Parts and Genuine Motor Accessories are among the trademarks of H-D Michigan, Inc.

PRODUCT REGISTERED MARKS

Alcantara S.p.A., Allen, Amp Multilock, Bluetooth, Brembo, Delphi, Deutsch, Dunlop, Dynojet, Fluke, G.E. Versilube,

Gunk, Hydroseal, Hylomar, Kevlar, Lexan, Loctite, Lubriplate, Keps, K&N, Magnaflux, Marson Thread-Setter Tool Kit, MAXI fuse, Molex, Michelin, MPZ, Multilock, NGK, Novus, Packard, Pirelli, Permatex, Philips, PJ1, Pozidriv, Robinair, S100, Sems, Snap-on, Teflon, Threadlocker, Torca, Torco, TORX, Tufoil, Tyco, Ultratorch, Velcro, X-Acto, and XM Satellite Radio are among the trademarks of their respective owners.



Index

A

Accessories and Cargo Guidelines.....	5,12
Accessory and Cargo Guidelines.....	12
Accessory Switch.....	73
ACR (Automatic Compression Release).....	135
Advanced Audio System.....	77,77,78,79,83, 84, 86, 97, 97, 98, 99, 99, 101, 103, 104, 106, 110, 112
Air Cleaner Filter.....	164
Air Deflectors.....	71
Air Suspension.....	61
Alarm.....	123
Alternator/Voltage Regulator.....	177
Audio Routing and Mixing.....	110
Audio System.....	77
Automatic Compression Release (ACR).....	135
Auxiliary Input Port.....	79
Auxiliary Lamps.....	174
Auxiliary/Fog Lamps.....	174

B

Battery.....	46,128,178,185,188
Belt Deflection.....	154
Brakes.....	55,158,211

Break-in.....	141
Break-in Maintenance.....	141
Break-in Riding Rules.....	132
Bulb Replacement.....	165,168,175,176

C

California Evaporative Emission Controls.....	214
Catalytic Converters.....	29
CB Operation.....	106
CB Transceiver.....	97
CD Operation.....	93
Chaincase Lubricant.....	151
Changing Engine Oil.....	145
Changing Primary Chaincase Lubricant.....	151
Charging the Battery.....	178
Chassis Lubrication.....	155
Checking Engine Oil.....	142
Checking Primary Chaincase Lubricant.....	151
Cigarette Lighter.....	72
Clean.....	205
Cleaning.....	201,205,206,206,207, 207, 208
Clutch.....	35,157
Controls.....	35,55,55,83,99,

Index

Coolant.....	101	EPA Noise Regulations.....	214
Cruise Control.....	21	ETC.....	39
Customer service.....	46,50,51		
	2		
D			
Dealer Locator.....	215	Factory Replacement Parts.....	213
Dealer Locator Phone Number.....	215	Fairing Controls.....	99
Denim Finish.....	206	Fairing Lower Vents.....	75
Drive Belt Deflection.....	154	Fob.....	116,127
		Four-Way Flashers.....	40
		Front Fork Bearings.....	157
		Front Fork Oil.....	156
		Front Panel Controls.....	79
		Fuel.....	28,29,46,60,164
		Fuel and Oil.....	28
		Fuel Filter.....	156
		Fuses.....	128,190
		Fuses and Relays.....	112,128,190
		G	
		Gasoline.....	28,29
		Gasoline Blends.....	28

Index

GAWR.....	12
GAWR/GVWR.....	12
Gear Shift Lever.....	55
GVWR.....	12

H

Hand Controls.....	35
Hand Grips.....	39
Handling CDs.....	97
Hazard Warning 4-Way Flasher.....	40,121
Hazard Warning Four-Way Flasher.....	40
Headlamp.....	41,165,168,170,172, 173
Headlamp Adjustment.....	170,172,173
Headlamp Alignment.....	170
Headlamp: Dual Headlamp Models.....	168
Headlamp: Single Headlamp Models.....	165
Headsets and Sockets.....	98
Heated Hand Grips.....	39,212
Heel-Toe Foot Shifter.....	55
Heel-Toe Shift Lever.....	55
Horn.....	35
Hydraulic Lifters.....	157

I

Ignition System.....	164
Importing a Motorcycle.....	216
Indicator Lamps.....	41,46
Instruments.....	41,42,46,59
Intercom.....	97,104
Intercom Operation.....	104

J

Jiffy Stand.....	58,59
Jump-Starting Battery.....	188

K

Key Fob.....	127
--------------	-----

L

Labels.....	18
Leather.....	206
Leather and Vinyl Care.....	206
Leather Care.....	206

Index

Left Handlebar Controls.....	83
Limited Radio Warranty.....	225
Limited Warranty.....	217,221,223
Lubrication.....	155,156
Luggage.....	12,65

M

Maintenance.....	141,141,142,142,145, 151,154,155,156,156,157,157,157,158,163,164,164,165,168,170, 172,173,175,176,177,178,213
Manual.....	1
Mirror Adjustment.....	59
Mirrors.....	59
Motorcycle Cleaning Products.....	201
Motorcycle Storage.....	196
MP3 (MPEG 2.5 Level III).....	93

N

National Highway Traffic Safety Administration.....	215
National Highway Traffic Safety Administration (NHTSA).....	215
Noise Control System.....	14

Noise Control System Limited Warranty.....	221
--------------------------------------------	-----

O

Octane Rating.....	29
Oil.....	142
Oil Applications.....	156
Oil Cooler.....	148
Oil Level.....	142
Operation.....	39,55,133,137
Owner Contact Information.....	216

P

Passenger Controls.....	101
Passenger Footboards.....	75
Passenger Footboards/Footrests.....	75
Passenger Headset Volume.....	104
Passenger Speakers.....	97
Polishing.....	205
Power Disconnect.....	128,190
Pre-Riding Checklist.....	133
Primary Chaincase.....	21,151

Index

Primary Chaincase Lubricant..... 151

R

Radio.....77
Rear Fork Pivot Shaft..... 158
Receiver Operation.....86
Reverse.....46
Rider to Passenger Speaker Balance.....99
Right Handlebar Controls.....84
Rules of the Road.....11

S

Saddlebags.....67,67
Saddlebags (FLHR/FLHT/FLHX/FLTR).....67
Saddlebags (FLHRC).....67
Saddlebags (FLHT/FLTR).....67
Saddlebags: All Except FLHRC.....67
Safe Operating Rules.....5
Safety.....12,18,141
Safety Defintions.....1
Seat.....193
Security System.....40,46,115,116,116,
118, 120, 123, 125, 126, 126, 127, 128

Service Intervals.....227
Service Literature.....231
Shifting Gears.....55,137
Shock Absorbers.....61,163
Sidecar Controls.....103
Sidestand.....58
Sidestand Interlock.....59
Siren Chirp Mode (Confirmation).....125
Smart Security System.....115,116,116,118,120,
121, 123, 125, 126, 126, 127, 128, 128
Sound System.....97
Spark Plug Replacement.....164
Spark Plugs.....164
Specifications.....21,29,142
SPKR Switch.....99
Starting the Engine.....134
Stopping the Engine.....137
Storage.....196
Suspension.....61
Suspension, Rear.....61

T

Tail Lamp.....176
Tail Lamp Assembly.....176

Index

Tail Lamp Bulb Replacement.....	176
Tire Replacement.....	162
Tires.....	27,160,162
Tour-Pak.....	65
Trademarks.....	231,232
Transmission.....	21,211
Transmission Lubrication.....	148
Troubleshooting.....	41,112,209,211,211, 211, 212
Turn Signal Bulbs (Bullet Style).....	174
Turn Signal Bulbs (Flat Lens Style).....	175
Turn Signal Lamps.....	175
Turn Signal Switches.....	40
Turn Signals.....	35,40,40,41,175

V

V.I.N.....	15
Vehicle Identification Number.....	15
VIN.....	15
Voltage Regulator/Alternator.....	177
VOX Microphones.....	99

W

Warranty.....	213,215,217,221,223, 225
Warranty Repair Work.....	215
Washing.....	205
Wheel Care.....	207
Wheels.....	207
Whitewall Tires.....	207
Windshield.....	71,208
Windshield Cleaning.....	208
Windshield (FLHR/C).....	71
Winter Lubrication.....	147

