



INSTRUCTIONS

94100003

2025-02-12



SOFTAIL FORWARD CONTROLS KIT CHROME

GENERAL INFORMATION

Table 1. General Information

Kits	Suggested Tools	Skill Level ⁽¹⁾
50700061	Safety Glasses, Torque Wrench, Loctite 243 (blue), E-Clip tool	

(1) Tightening to torque value or other moderate tools and techniques required

KIT CONTENTS

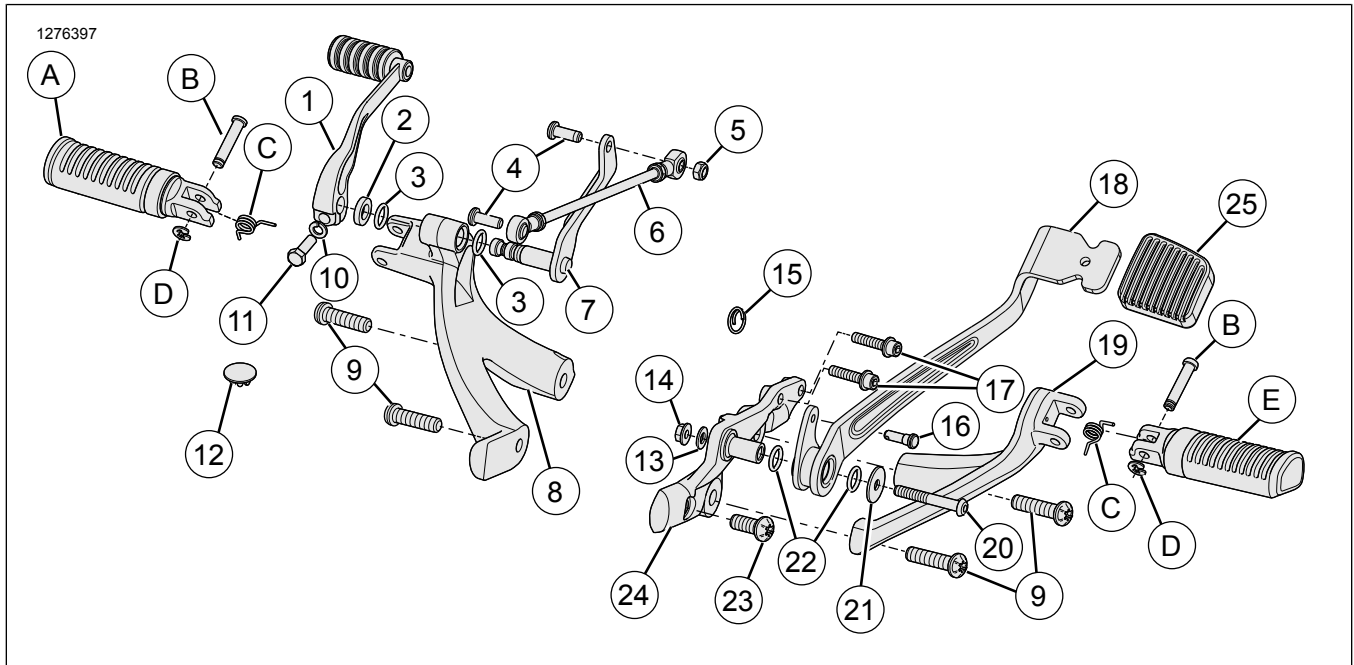

Figure 1. Kit Contents: Forward Controls (Chrome)

Table 2. Kit Contents: Forward Controls Kit (Chrome)

<input checked="" type="checkbox"/>	Verify that all contents are present in the kit before installing or removing items from vehicle.				
	Item	Qty	Description	Part No.	Notes
<input type="checkbox"/>	1	1	Shift lever sub-assembly	33600124	Bag A
<input type="checkbox"/>	2	1	Nylon washer	6057	Bag A
<input type="checkbox"/>	3	2	O-ring, small	11191	Bag A
<input type="checkbox"/>	4	2	Screw, socket head button	4387	Bag A
<input type="checkbox"/>	5	1	Lock nut	7727	Bag A
<input type="checkbox"/>	6	1	Shifter linkage rod	33600123	Bag A
<input type="checkbox"/>	7	1	Shifter rod lever	33600132	Bag A
<input type="checkbox"/>	8	1	Foot support bracket, left	33600212	Bag A
<input type="checkbox"/>	9	4	Cap screw, button head, 3/8-16 x 1.62 inch	10200536	Bag C
<input type="checkbox"/>	10	1	Lockwasher	7041	Bag A
<input type="checkbox"/>	11	1	Screw, hex head	4017	Bag A
<input type="checkbox"/>	12	1	Primary cover plug	25701149	Bag A
<input type="checkbox"/>	13	1	Washer, small	6702	Bag B
<input type="checkbox"/>	14	1	Flange nut	7531	Bag B
<input type="checkbox"/>	15	1	Cotter circle	51938-04	Bag B
<input type="checkbox"/>	16	1	Rear brake clevis pin	42460-80B	Bag B
<input type="checkbox"/>	17	2	Screw	10500022	Bag B
<input type="checkbox"/>	18	1	Brake pedal, chrome	50600209	Bag B
<input type="checkbox"/>	19	1	Foot support bracket, right	50500913	Bag B
<input type="checkbox"/>	20	1	Screw, button head, TORX 2.25 inch	10200851	Bag B
<input type="checkbox"/>	21	1	Washer	6237	Bag B
<input type="checkbox"/>	22	2	O-ring, large	11364	Bag B
<input type="checkbox"/>	23	1	Cap screw, button head, 3/8-16 x 1 inch	4512A	Bag B
<input type="checkbox"/>	24	1	Brake pedal bracket	50600206	Bag B
<input type="checkbox"/>	25	1	Brake pedal pad	50600223	Bag B
Items mentioned in text, but not included in kit					
<input checked="" type="checkbox"/>	A	1	Footpeg, left	50501107	
<input checked="" type="checkbox"/>	B	2	Footpeg clevis pin	50500702	
<input checked="" type="checkbox"/>	C	2	Footpeg torsion spring	50500703	
<input checked="" type="checkbox"/>	D	2	E-clip	50500701	

Table 2. Kit Contents: Forward Controls Kit (Chrome)

Verify that all contents are present in the kit before installing or removing items from vehicle.				
Item	Qty	Description	Part No.	Notes
✓	E	1	Footpeg, right	50501106

The contents of bag A will be used for left side assemblies, bag B will be used for right side assemblies and bag C will be used for both left and right sides.

GENERAL

Instruction sheet is also available electronically. To verify you are using the most current version available, do one of the following:

- Go to h-d.com/isheets
- Scan QR code in upper left corner of the instruction sheet

NOTE

This instruction sheet **may have a Supplemental Video** to assist installer in clarifying a certain part of the assembly. A linked video would be located at the end of this instruction sheet.

Models

For model fitment information, see the Parts and Accessories (P&A) Retail Catalog or the Parts and Accessories section of www.harley-davidson.com.

Contact Harley-Davidson Customer Support Center at 1-800-258-2464 (U.S. only) or 1-414-343-4056.

Installation Requirements

⚠ WARNING

Rider and passenger safety depend upon the correct installation of this kit. If the procedure is not within your capabilities or you do not have the correct tools, have a Harley-Davidson dealer perform the installation. Improper installation of this kit could result in death or serious injury. (00308b)

⚠ WARNING

Brakes are a critical safety component. Contact a Harley-Davidson dealer for brake repair or replacement. Improperly serviced brakes can adversely affect brake performance, which could result in death or serious injury. (00054a)

LOCTITE 243 MEDIUM STRENGTH THREADLOCKER AND SEALANT (BLUE) (99642-97)

E-CLIP TOOL (PART NUMBER: HD-52369)

LEFT SIDE

Disassemble Left Side

1. See Figure 7. Remove footpeg from foot support bracket. Retain footpeg, E-clip, clevis pin, and torsion spring for later use.

- a. Remove E-clip (3).

Special Tool: E-CLIP TOOL (HD-52369)

NOTE

When removing E-clip, use E-clip tool to prevent damage to painted surfaces.

- b. Remove clevis pin (1).
 - c. Remove footpeg (4).
 - d. Remove torsion spring (2).
2. See Figure 2. Remove the left mid foot support bracket (3).
 - a. Remove screws (2).
 - b. Remove foot support bracket.
 3. Remove and discard plastic plug (1) if present.
 4. See Figure 3. Remove shifter assembly.
 - a. Remove screw (5) to free shifter rod (4) from rear shifter rod lever (3).
 - b. Remove pinch screw (1) from front shifter rod lever (2).
 - c. Pull foot shift lever (6) and shaft (8) outward until front shifter rod lever (2) is free.
 - d. Remove front shifter rod lever and shifter rod.
 - e. Remove foot shift lever, shaft and spacer (7).

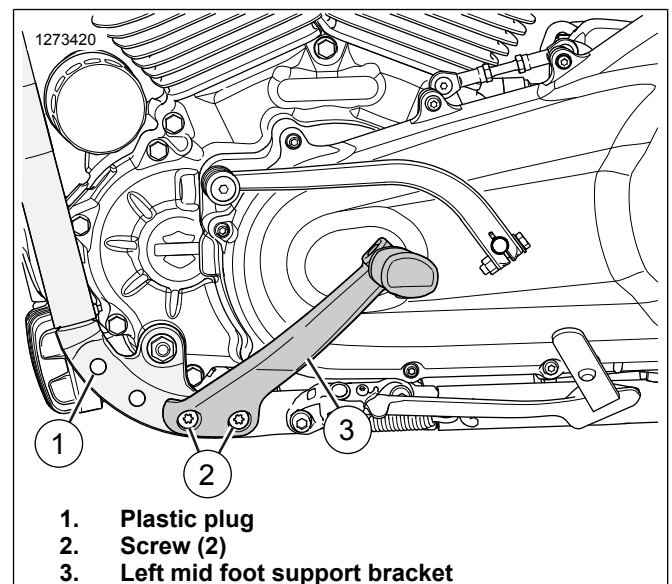
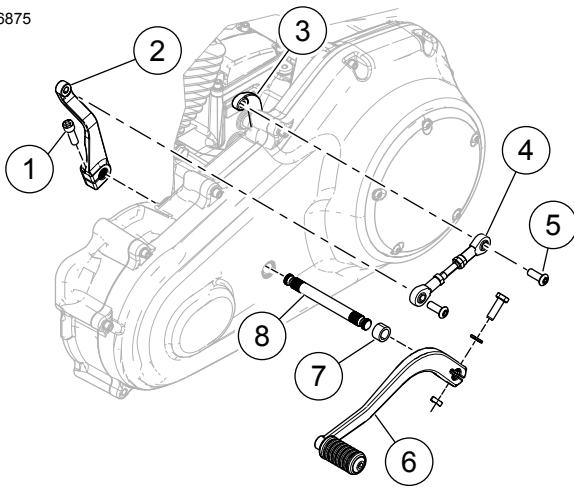

Figure 2. Left Mid Foot Support Bracket

1296875



- 1. Pinch screw
- 2. Shifter rod lever, front
- 3. Shifter rod lever, rear
- 4. Shifter rod
- 5. Screw
- 6. Foot shift lever
- 7. Spacer
- 8. Shaft

Figure 3. Shift Linkage: Mid-Mount Foot Control Models

Pre-Assemble Left Side Kit Components

1. See Figure 4. Install footpeg to foot support bracket.
 - a. Insert short leg of torsion spring (3) into hole in footpeg (1).
 - b. Insert long leg of torsion spring into hole in left foot support bracket (10).

- c. Rotate footpeg into position and install clevis pin (2).
- d. Install E-clip (14).

Special Tool: E-CLIP TOOL (HD-52369)

NOTE

When installing E-clip, use E-clip tool to prevent damage to painted surfaces.

2. Install shifter assembly to foot support bracket.
 - a. Install first small O-ring (11) onto shaft of shift rod lever (9).
 - b. Install shift rod lever through hole in left foot support bracket (10).
 - c. Install second small O-ring (11) onto shaft of shift rod lever.
 - d. Install nylon washer (5) onto shaft of shift rod lever.
 - e. See Figure 5. Align shift lever with shift rod lever at an angle of 65–75°.
 - f. See Figure 4. Install shift lever (4) onto shift rod lever.
 - g. Install lock washer (12) and screw (13). Tighten.
Torque: 24.4–29.8 N·m (18–22 ft-lbs) *Shift lever pinch screw*
 - h. Install shifter linkage rod (8) to shift rod lever (9).
 - i. Install screw (6) and nut (7). Tighten.
Torque: 13.5–19 N·m (120–170 in-lbs) *Shifter rod screw*

1276112

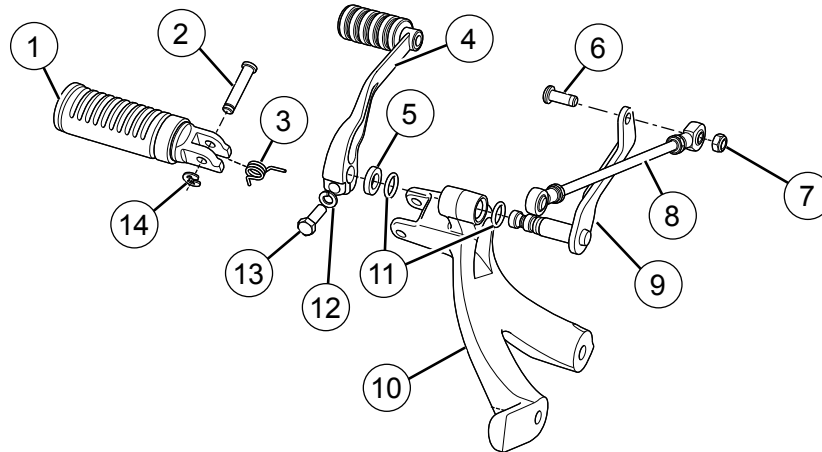

- 1. Left footpeg
- 2. Footpeg clevis pin
- 3. Footpeg torsion spring
- 4. Shift lever sub-assembly
- 5. Nylon washer
- 6. Screw
- 7. Nut
- 8. Shifter linkage rod
- 9. Shift rod lever
- 10. Left foot support bracket
- 11. O-ring - small (2)
- 12. Lock washer
- 13. Screw
- 14. E-clip

Figure 4. Left Side Pre-Assemble

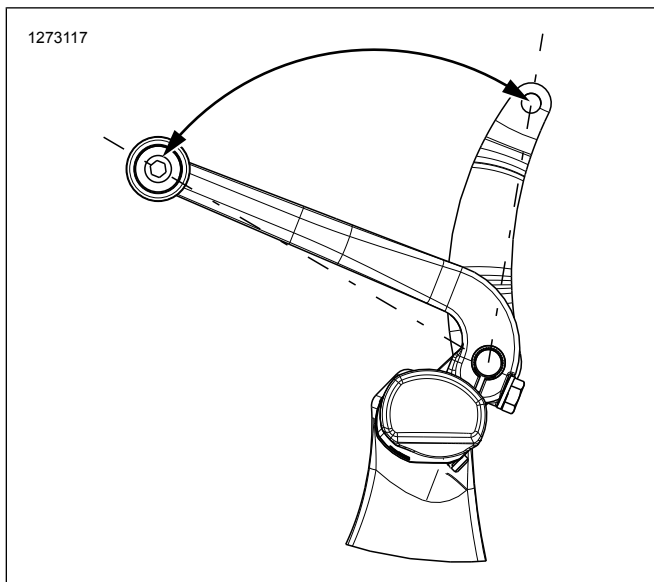

Figure 5. Shift lever assembly angle

Installation Left Side

1. Install left foot support assembly.
 - a. See Figure 1. Select left foot support bracket assembly and screws (12) from kit.
 - b. See Figure 6. Apply threadlocker to screws (6).
 LOCTITE 243 MEDIUM STRENGTH
 THREADLOCKER AND SEALANT (BLUE)
 (99642-97)
 - c. Install left foot support assembly (5).
 - d. Install screws (6). Tighten.
 Torque: 54–61 N·m (40–45 ft-lbs) *Left-hand foot support screws*
2. Install plug (4) into shifter shaft hole in primary cover.
3. Install shifter linkage.
 - a. Install shifter linkage rod (1) to rear shifter rod lever (3) with screw. Tighten.
 Torque: 13.5–19 N·m (120–170 **in-lbs**) *Shifter rod screw*
 - b. Adjust shifter rod ends (7) for rider posture and tighten jam nuts (8).
 Torque: 9–13.5 N·m (80–120 **in-lbs**) *Shifter rod jam nuts*

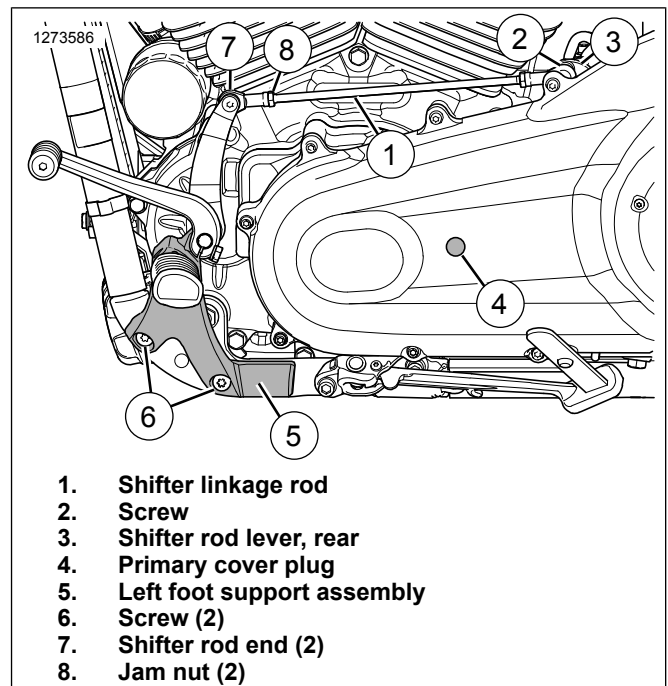

Figure 6. Left side forward controls

1. Shifter linkage rod
2. Screw
3. Shifter rod lever, rear
4. Primary cover plug
5. Left foot support assembly
6. Screw (2)
7. Shifter rod end (2)
8. Jam nut (2)

RIGHT SIDE

Disassemble Right Side

1. See Figure 7. Remove footpeg from foot support bracket. Retain footpeg, E-clip, clevis pin, and torsion spring for later use.

NOTE

When removing E-clip, use E-clip tool to prevent damage to painted surfaces.

- a. Remove E-clip (3).
 Special Tool: E-CLIP TOOL (HD-52369)
 - b. Remove clevis pin (1).
 - c. Remove footpeg (4).
 - d. Remove torsion spring (2).
2. See Figure 8. Remove right side foot support bracket.
 - a. Remove front linkage screw (2).
 - b. Remove screws (7).
 - c. Remove foot support bracket (1).
 3. Remove rear master cylinder from bracket.
 - a. See Figure 9. Remove cotter circle (1).
 - b. Remove clevis pin (2).
 - c. See Figure 8. Remove screws (4).
 - d. Support rear brake master cylinder (3).

4. Remove brake pedal bracket.
 - a. Remove screw (5).
 - b. Remove brake pedal bracket (6).

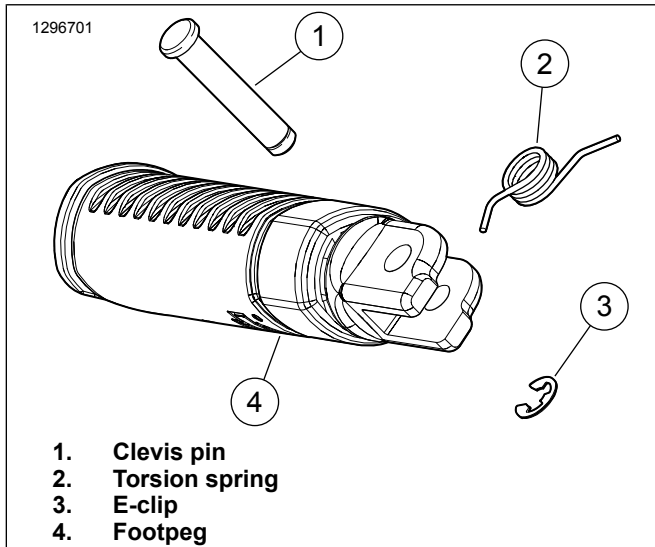

Figure 7. Rider Footpeg (Typical)

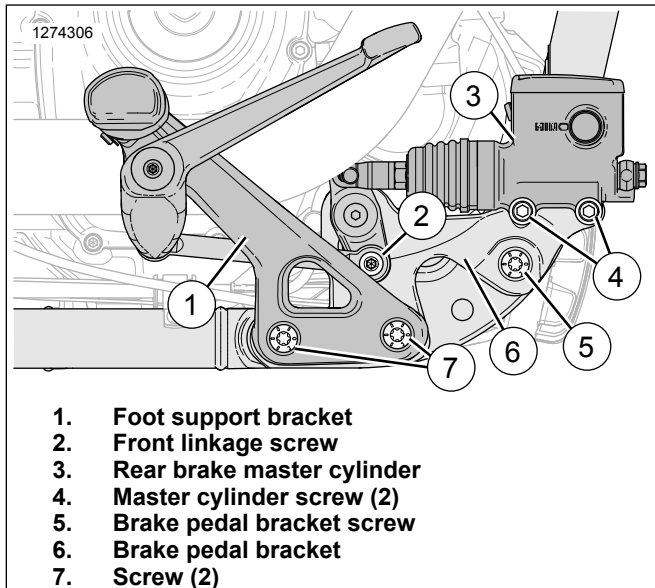

Figure 8. Right Side Mid Controls

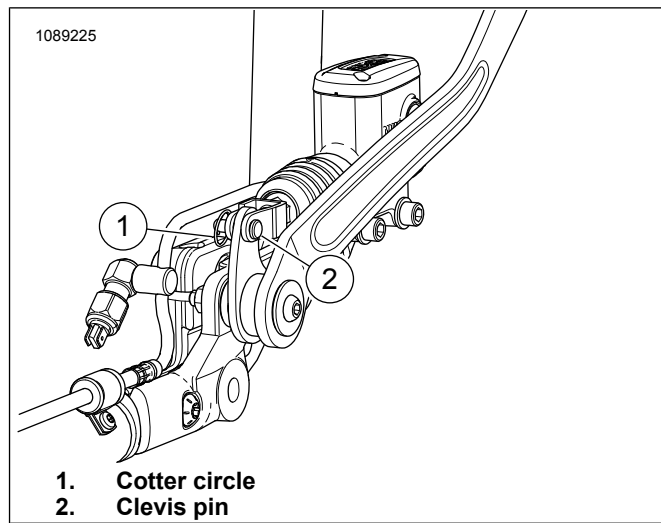

Figure 9. Rear Master Cylinder - Rear View: (exhaust remove for clarity)

Pre-Assemble Right Side Kit Components

1. See Figure 10. Install footpeg to foot support bracket.
 - a. Insert short leg of torsion spring (4) into hole in footpeg (6).
 - b. Insert long leg of torsion spring into hole in right foot support bracket (3).
 - c. Rotate footpeg into position and install clevis pin (5).
 - d. Install E-clip (7).

Special Tool: E-CLIP TOOL (HD-52369)

NOTE

When installing E-clip, use E-clip tool to prevent damage to painted surfaces.

2. Assemble brake pedal.
 - a. Install first large O-ring (10) onto brake pedal mounting bracket (1).
 - b. Install brake pedal (2) onto mounting bracket.
 - c. Install second large O-ring (10) onto brake pedal mounting bracket.
 - d. Install screw (8) and large washer (9).
 - e. Install small washer (11) and nut (12). Tighten.
Torque: 24.4–29.8 N·m (18–22 ft-lbs) *Brake pedal pivot screw*
 - f. Install brake pedal pad (13) to brake pedal.

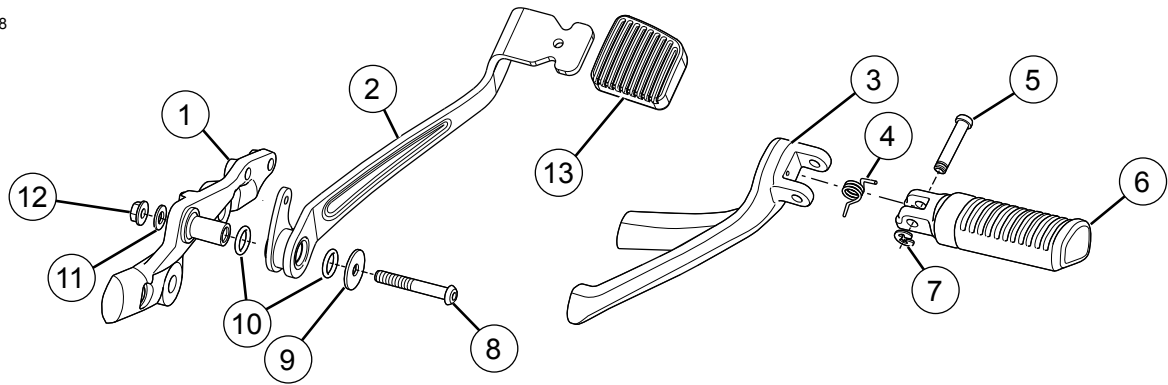

- | | |
|-------------------------------|------------------------|
| 1. Brake pedal bracket | 8. E-clip |
| 2. Brake pedal - Black | 9. Screw |
| 3. Right foot support bracket | 10. Washer - large |
| 4. Footpeg return spring | 11. O-ring - large (2) |
| 5. Footpeg clevis pin | 12. Washer - small |
| 6. Right footpeg | 13. Nut |
| 7. Wearpeg | 14. Brake pedal pad |

Figure 10. Right Side Pre-Assemble

Installation Right Side

1. See Figure 1. Select the brake pedal bracket assembly and screw (23) from kit.
2. See Figure 11. Install brake pedal mounting bracket.
 - a. Apply threadlocker to screw (2).
LOCTITE 243 MEDIUM STRENGTH
THREADLOCKER AND SEALANT (BLUE)
(99642-97)
 - b. Install brake pedal bracket (1).
 - c. Install screw (2). Hand tighten.
3. Install rear master cylinder to brake pedal mounting bracket.
 - a. Install rear master cylinder (5).

NOTE

Verify that the brake pedal link is between the master cylinder yoke when placing the master cylinder into place.

- b. See Figure 9. Install clevis pin (2).
 - c. Install cotter circle (1).
 - d. See Figure 11. Install screws (4). Tighten.
Torque: 24–30 N·m (18–22 ft-lbs) *Rear master cylinder mounting screws*
4. Install right foot support assembly.
 - a. See Figure 1. Select right foot support bracket assembly and screws (9) from kit.
 - b. See Figure 11. Apply threadlocker to screws (3).

- c. Install right foot support assembly (6).
- d. Install screws (3).
- e. Tighten screws (2 and 3).
Torque: 54–61 N·m (40–45 ft-lbs) *Right foot support screws*

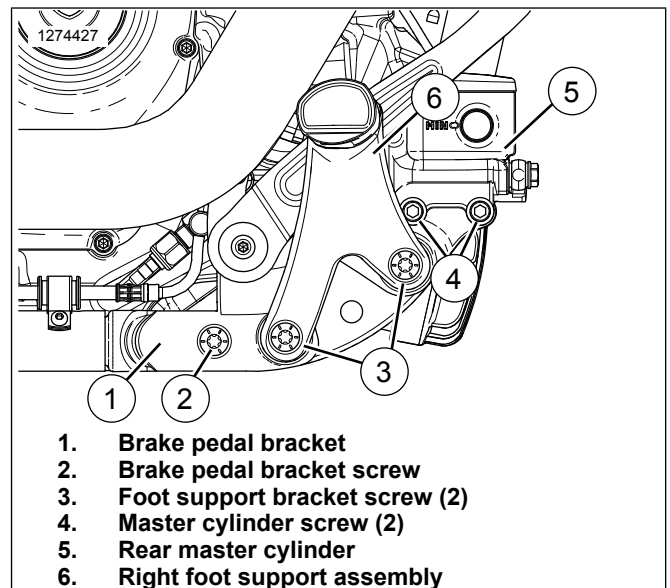

- | |
|-----------------------------------|
| 1. Brake pedal bracket |
| 2. Brake pedal bracket screw |
| 3. Foot support bracket screw (2) |
| 4. Master cylinder screw (2) |
| 5. Rear master cylinder |
| 6. Right foot support assembly |

Figure 11. Right Foot Support Bracket