

SPORTSTER® MODELS

2005 HARLEY-DAVIDSON® INTERNATIONAL OWNER'S MANUAL



Harley-Davidson Motor Company
Service Communications
Milwaukee WI 53208 USA

2026-04-10



99468-051A

English

Printed in the USA

2005 HARLEY-DAVIDSON® INTERNATIONAL OWNER'S MANUAL
SPORTSTER® MODELS - 99468-051A



99468-051A

SPORTSTER® MODELS

2005 HARLEY-DAVIDSON® INTERNATIONAL OWNER'S MANUAL



99468-051A

2005 HARLEY-DAVIDSON® INTERNATIONAL OWNER'S MANUAL - SPORTSTER® MODELS

TABLE OF CONTENTS

INTRODUCTION

Safety Definitions.....	1
Your Owner's Manual.....	1
We Care About You.....	1
United States Owners.....	2
Customer Service Assistance.....	2

SAFETY FIRST

Safe Operating Rules: Sportster Models.....	5
Rules of the Road.....	11
Accessories and Cargo.....	12
Accessory and Cargo Guidelines.....	12

IDENTIFICATION

2005 Sportster Models.....	15
Vehicle Identification Number.....	28

SPECIFICATIONS

Specifications: 2005 Sportster Models.....	31
Tire Data.....	35
Gasoline Blends.....	36
Fuel.....	37
Catalytic Converters.....	37

CONTROLS AND INDICATORS

General: Controls and Indicators.....	39
Ignition/Headlamp Key Switch: Sportster Models.....	39
Hand Controls: Basic Operation.....	41
Electric Starter Switch.....	41
Engine OFF/RUN Switch.....	41
Throttle Control Grip.....	42
Clutch Hand Lever.....	42
Horn Switch.....	43
Headlamp Dimmer Switch.....	43
Turn Signal Switches.....	43
Turn Signal Switch Operation.....	44
Hazard Warning 4-Way Flasher.....	45
INDICATOR LAMPS.....	45
Instruments: Sportster Models.....	46
Speedometer.....	46
Tachometer.....	47
Trip Odometer.....	47
Tip Indicator Lamp.....	47
Enrichener.....	49
Carbureted Models Only.....	49
Gear Shift Lever.....	50
Brake System.....	51
Jiffy Stand.....	51
Rear View Mirrors.....	52

TABLE OF CONTENTS

Fuel Supply Valve.....	53
Carbureted Models Only.....	53
Fuel Filler Cap: Sportster Models.....	54
Fork Lock: Sportster Models.....	55
Shock Absorbers: Sportster Models.....	57
Rear Shock Preload Adjustment (All Models).....	57

H-D FACTORY SECURITY SYSTEM

Basic Security System Operation.....	61
Security System Options.....	61
FCC Regulations.....	61
Arming The System.....	61
Using Key Fob.....	62
Using Auto-arming.....	62
Disarming The System.....	62
Using Key Fob.....	63
Using Personal Code.....	63
Security Status Lamp.....	65
Transport Mode.....	65
Security System Custom Setup.....	66
Key Fob Assignment.....	66
Procedure.....	66
Personal Code.....	67
Creating Code for the First Time.....	67
Modifying Existing Codes.....	68

Enable Auto-arming Selection.....	72
Alarm Sensitivity.....	73
Storage Mode Configuration.....	74
Security System Maintenance.....	75
Key Fob Battery Replacement.....	75
Disabling the System.....	76
Battery Disconnects and Configuring.....	77
Troubleshooting the Security System.....	77
Siren Diagnostics.....	77

OPERATION

Operating Recommendations: Sportster Models.....	79
Break-in Riding Rules.....	80
The First 500 Miles (800 Kilometers).....	80
Pre-Riding Checklist.....	81
Starting the Engine: Carbureted Models.....	82
C.V. Carburetors.....	83
Cool Engine.....	83
Warm or Hot Engine.....	84
Stopping the Engine.....	84
Shifting Gears.....	84
Getting Started.....	84
Upshift (Acceleration).....	85
Downshift (Deceleration).....	85

TABLE OF CONTENTS

MAINTENANCE AND LUBRICATION

Safe Operating Maintenance.....	89	Carbureted Models Only.....	105
Break-in Maintenance.....	89	CLUTCH.....	106
Engine Lubrication.....	89	Hydraulic Lifters.....	106
Checking Oil Level: Sportster Models.....	90	Front Fork Bearings.....	106
Removing and Replacing Oil Filler Cap.....	90	Rear Fork Pivot Shaft.....	107
Oil Level Cold Check.....	91	Brakes: Sportster Models.....	107
Oil Level Hot Check.....	91	Tires.....	108
Changing Oil and Oil Filter: Sportster Models.....	93	Tire Replacement.....	110
Removal and Draining.....	93	Inspection.....	110
Installation and Filling.....	96	When To Replace Tires.....	110
Winter Lubrication.....	97	Shock Absorbers.....	111
Transmission Lubrication: Sportster Models.....	97	Spark Plugs.....	112
Check Lubricant Level.....	98	Ignition.....	112
Changing Lubricant.....	99	Carburetor.....	112
Primary Chain Adjustment: Sportster Models.....	101	Air Cleaner.....	113
General.....	101	HEADLAMP.....	114
Procedure.....	102	Headlamp Alignment: Sportster Models.....	117
Rear Drive Belt: Sportster Models.....	103	Inspection.....	117
General.....	103	Adjustment.....	118
Checking Deflection.....	103	Turn Signal Bulbs: Bullet Style.....	119
Chassis Lubrication.....	104	Replacement.....	119
Oil Applications.....	105	Alignment.....	119
Front Fork Oil.....	105	Alternator/Voltage Regulator.....	120
Fuel Strainer.....	105	Charging Rate.....	120
		Battery: General.....	121
		Type.....	121

TABLE OF CONTENTS

Voltmeter Test.....	123	Wheel Care.....	140
Cleaning and Inspection.....	123	Windshields.....	141
Charging.....	124	TROUBLESHOOTING	
Storage.....	126	Troubleshooting: General.....	143
Battery: Sportster Models.....	127	Engine.....	143
Disconnection and Removal.....	127	Starter Does Not Operate or Does Not Turn Engine Over.....	143
Installation and Connection.....	128	Engine Turns Over But Does Not Start.....	143
Jump Starting.....	129	Starts Hard.....	143
Positive Cable.....	130	Starts But Runs Irregularly or Misses.....	144
Negative Cable.....	130	A Spark Plug Fouls Repeatedly.....	144
Electrical Protection: Sportster Models.....	132	Pre-ignition or Detonation (Knocks or Pings).....	144
Fuse Replacement.....	132	Overheats.....	144
Replacing the Maxi-Fuse.....	133	Excessive Vibration.....	144
Seat: Sportster Models.....	135	Electrical System.....	145
Removal.....	135	Alternator Does Not Charge.....	145
Installation.....	135	Alternator Charge Rate is Below Normal.....	145
Motorcycle Storage.....	136	Carburetor.....	145
Placing Motorcycle in Storage.....	136	Carburetor Floods.....	145
Removing Motorcycle From Storage.....	137	Transmission.....	145
ACCESSORIES MAINTENANCE		Transmission Shifts Hard.....	145
General Maintenance.....	139	Transmission Jumps Out of Gear.....	145
Cleaning Your Motorcycle.....	139	Clutch Slips.....	145
Leather Care.....	139	Clutch Drags or Does Not Release.....	145
Whitewall Tires.....	140		

TABLE OF CONTENTS

Clutch Chatters.....	145
Brakes.....	146
Brakes Do Not Hold Normally.....	146

WARRANTIES AND RESPONSIBILITIES

Warranty and Maintenance.....	147
Keeping It All Harley-Davidson.....	147
Important Moving Information.....	148
Warranty/Service Information.....	148
Owner Transfer Identification Form.....	148
Required Documentation for Imported Motorcycles.....	148

LIMITED MOTORCYCLE WARRANTY

2005 HARLEY-DAVIDSON MOTORCYCLE LIMITED WARRANTY.....	149
24 Months/Unlimited Miles.....	149
Duration.....	149
Owner's Obligations.....	149
Exclusions.....	149
Other Limitations.....	150
Important: Read Carefully.....	150

MAINTENANCE SCHEDULING

Regular Service Intervals.....	153
Service Literature.....	156



NOTES



SAFETY DEFINITIONS

Statements in this manual preceded by the following words are of special significance:

▲ WARNING

WARNING indicates a potentially hazardous situation which, if not avoided, could result in death or serious injury. (00119a)

▲ CAUTION

CAUTION indicates a potentially hazardous situation which, if not avoided, may result in minor or moderate injury. (00139a)

NOTICE

NOTICE indicates a potentially hazardous situation which, if not avoided, may result in property damage. (00140b)

NOTE

A NOTE refers to important information and is placed in italic type. It is recommended that you take special notice of these items.

HARLEY-DAVIDSON MOTORCYCLES ARE FOR ON-ROAD USE ONLY

This motorcycle is not equipped with a spark arrester and is designed to be used only on the road. Operation of off-road usage in some areas may be illegal. Obey local laws and regulations. This manual should be considered a permanent part of the motorcycle and should remain with the motorcycle when resold.

VISIT THE HARLEY-DAVIDSON WEB SITE

<http://www.harley-davidson.com>

YOUR OWNER'S MANUAL

We Care About You

Welcome to the Harley-Davidson Motorcycling Family! When enjoying your Harley-Davidson motorcycle, be sure to ride safely, respectfully and within the limits of the law and your abilities. Always wear a helmet, proper eyewear and protective clothing, and insist your passenger does too. Never ride while under the influence of alcohol or drugs. Know your Harley and read and understand your owner's manual from cover to cover.

This manual has been prepared to acquaint you with the operation, care and maintenance of your motorcycle and to provide you with important safety information. Follow these instructions carefully for maximum motorcycle performance and for your personal motorcycling safety and pleasure. Your Owner's Manual contains instructions for operation and minor

maintenance. Major repairs are covered in the Harley-Davidson Service Manual. Such major repairs require the attention of a skilled technician and the use of special tools and equipment. Your Harley-Davidson dealer has the facilities, experience and Genuine Harley-Davidson parts necessary to properly render this valuable service. We recommend that any emission system maintenance be performed by an authorized Harley-Davidson dealer.

Attend a rider safety course. To enroll in a Harley-Davidson Riding Academy course, call 1-414-343-4056 (U.S.) or visit www.harley-davidson.com/learntoride. In the United States, for information about Motorcycle Safety Foundation rider courses, call 1-800-446-9227 or visit www.msf-usa.org.

United States Owners

Your Harley-Davidson motorcycle conforms to all applicable U.S. Federal Motor Vehicle Safety Standards and U.S. Environmental Protection Agency regulations effective on the date of manufacture. Protect your privilege to ride by joining the American Motorcyclist Association. Visit www.americanmotorcyclist.com for more information.

Harley-Davidson reserves the right to change specifications, equipment or designs at any time without notice and without incurring obligation.

CUSTOMER SERVICE ASSISTANCE

Most sales or service issues are resolved at the dealership.

1. Discuss your problem with the appropriate personnel at the dealership in the Sales, Service or Parts area. If that proves unsuccessful, speak to the owner of the dealership or the general manager.
2. If you cannot resolve the issue with the dealership, contact the Harley-Davidson Customer Support Center. Harley-Davidson Motor Company Attention: Harley-Davidson Customer Support Center P.O. Box 653 Milwaukee, Wisconsin 53201 1-800-258-2464 (U.S. only) 1-414-343-4056

For customers outside the US, contact your local Harley-Davidson market office, call 1-414-343-4056 or visit harley-davidson.com.

Table 2. Vehicle and Personal Data

PERSONAL INFORMATION	DEALER INFORMATION
Date of Purchase:	
Name:	Name:
Address:	Address:
Address:	Address:
Vehicle Identification Number:	Sales Contact:
Key Number:	Service Contact:



NOTES



SAFE OPERATING RULES: SPORTSTER MODELS

Before operating your new motorcycle it is your responsibility to read and follow the operating and maintenance instructions in this manual, and follow these basic rules for your personal safety.

- Know and respect the rules of the road (see RULES OF THE ROAD section). Carefully read and observe the rules contained in the RIDING TIPS booklet accompanying this Owner's Manual. Read and familiarize yourself with the contents of the MOTORCYCLE HANDBOOK for your state.
- Before starting engine, check for proper operation of brake, clutch, shifter, throttle controls, correct fuel and oil supply.

⚠ WARNING

Harley-Davidson parts and accessories are designed for Harley-Davidson motorcycles. Using non-Harley-Davidson parts or accessories can adversely affect performance, stability or handling, which could result in death or serious injury. (00001b)

⚠ WARNING

Stop the engine when refueling or servicing the fuel system. Do not smoke or allow open flame or sparks near gasoline. Gasoline is extremely flammable and highly explosive, which could result in death or serious injury. (00002a)

- Use only Harley-Davidson approved parts and accessories. Use of certain other manufacturer's performance parts will void your new motorcycle warranty. See your Harley-Davidson dealer for details.

When refueling your motorcycle, the following rules should be observed.

- Refuel in a well ventilated area with the engine turned off.
- Remove fuel filler cap slowly.
- Do not smoke or allow open flames or sparks when refueling or servicing the fuel system.
- Always close the fuel supply valve when the engine is not running. This prevents flooding of the carburetor and the surrounding area with gasoline.
- Do not fill fuel tank above the bottom of the filler neck insert.
- Leave air space to allow for fuel expansion.

⚠ WARNING

Do not store motorcycle with gasoline in tank within the home or garage where open flames, pilot lights, sparks or electric motors are present. Gasoline is extremely flammable and highly explosive, which could result in death or serious injury. (00003a)

⚠ WARNING

Engine exhaust from this product contains chemicals known to the State of California to cause cancer, and birth defects or other reproductive harm. (00004f)

⚠ WARNING

Do not run motorcycle in a closed garage or confined area. Inhaling motorcycle exhaust, which contains poisonous carbon monoxide gas, could result in death or serious injury. (00005a)

⚠ WARNING

The jiffy stand locks when placed in the full forward (down) position with vehicle weight on it. If the jiffy stand is not in the full forward (down) position with vehicle weight on it, the vehicle can fall over which could result in death or serious injury. (00006a)

⚠ WARNING

Be sure jiffy stand is fully retracted before riding. If jiffy stand is not fully retracted, it can contact the road surface causing a loss of vehicle control, which could result in death or serious injury. (00007a)

- A new motorcycle must be operated according to the special break-in procedure. See OPERATION > BREAK-IN RIDING RULES (Page 80).
- Operate motorcycle only at moderate speed and out of traffic until you have become thoroughly familiar with its operation and handling characteristics under all conditions.

NOTE

We recommend that you obtain information and formal training in the correct motorcycle riding technique. The Motorcycle Safety Foundation® offers beginning and advanced rider safety courses. Call (949)727-3227 for information.

⚠ WARNING

Travel at speeds appropriate for road and conditions and never travel faster than posted speed limit. Excessive speed can cause loss of vehicle control, which could result in death or serious injury. (00008a)

- Do not exceed the legal speed limit or drive too fast for existing conditions. Always reduce speed when poor driving conditions exist. High speed increases the influence of any other condition affecting stability and increases the possibility of loss of control.
 - Pay strict attention to road surfaces and wind conditions. Any two wheeled vehicle may be subject to upsetting forces such as wind blasts from passing trucks, holes in the pavement, rough road surfaces, rider control error, etc. These forces may influence the handling characteristics of your motorcycle. If this happens, reduce speed and guide the motorcycle with a relaxed grip to a controlled condition. Do not brake abruptly or force the handlebar. This may aggravate an unstable condition.
 - Keep cargo weight concentrated close to the motorcycle and as low as possible to minimize the change in the motorcycle's center of gravity. Distribute weight evenly on both sides of the vehicle and do not load bulky items too far behind the rider or add weight to the handlebars or front forks. Do not exceed maximum specified load in each saddlebag.
- Operate your motorcycle defensively. Remember, a motorcycle does not afford the same protection as an automobile in an accident. One of the most common accident situations occurs when the driver of the other vehicle fails to see or recognize a motorcycle and turns left into the on-coming motorcyclist. Operate only with headlamp on.

▲ WARNING

Avoid contact with exhaust system and wear protective clothing that completely covers legs while riding. Exhaust pipes and mufflers get very hot when engine is running and remain too hot to touch, even after engine is turned off. Failure to wear protective clothing could result in burns or other serious injury. (00009a)

- Wear an approved helmet, clothing, and foot gear suited for motorcycle riding. Bright or light colors are best for greater visibility in traffic, especially at night. Avoid loose, flowing garments and scarves.
- When carrying passengers, it is your responsibility to instruct them on proper riding procedures. (See Riding Tips for Motorcyclist included in your Harley-Davidson Owner's Kit.)

NOTE

New riders should gain experience under various conditions while driving at moderate speeds.

- Do not allow other individuals, under any circumstances, to operate your motorcycle unless you know they are experienced, licensed riders and are thoroughly familiar with the operation of your particular motorcycle.
- Protect your motorcycle against theft. After parking your motorcycle, lock the steering head and remove ignition key from switch. Set security alarm if present.
- Safe motorcycle operation requires alert mental judgment combined with a defensive driving attitude. Do not allow fatigue, alcohol or drugs to endanger your safety or that of others.
- Vehicles equipped with a sound system should have the volume adjusted to a nondistracting level before operating vehicle.
- Maintain your motorcycle in proper operating condition in accordance with Table 37. Particularly important to motorcycle stability is proper tire inflation pressure, tread condition, and proper adjustment of wheel bearings and steering head bearings.

⚠ WARNING

Do not operate vehicle with forks locked. Locking the forks restricts the vehicle's turning ability, which could result in death or serious injury. (00035a)

⚠ WARNING

Perform the service and maintenance operations as indicated in the regular service interval table. Lack of regular maintenance at the recommended intervals can affect the safe operation of your motorcycle, which could result in death or serious injury. (00010a)

⚠ WARNING

Do not operate motorcycle with loose, worn or damaged steering or suspension systems. Contact a Harley-Davidson dealer for repairs. Loose, worn or damaged steering or suspension components can adversely affect stability and handling, which could result in death or serious injury. (00011a)

⚠ WARNING

Regularly inspect shock absorbers and front forks. Replace leaking, damaged or worn parts that can adversely affect stability and handling, which could result in death or serious injury. (00012a)

⚠ WARNING

Use Harley-Davidson replacement fasteners. Aftermarket fasteners can adversely affect performance, which could result in death or serious injury. (00013a)

- See a Harley-Davidson service manual for proper torque values.
- Aftermarket fasteners may not have the specific property requirements to perform properly.

NOTICE

883cc and 1200cc Harley-Davidson motorcycles have a plugged carburetor overflow fitting. The fuel supply valve on the vehicle should be turned off when the vehicle is not operating. Failure to do so may result in fuel drainage into the engine, dilution of the engine oil and engine damage. (00146b)

⚠ WARNING

Be sure tires are properly inflated, balanced, undamaged, and have adequate tread. Inspect your tires regularly and see a Harley-Davidson dealer for replacements. Riding with excessively worn, unbalanced, improperly inflated, overloaded or damaged tires can lead to tire failure and adversely affect stability and handling, which could result in death or serious injury. (00014b)

⚠ WARNING

Replace punctured or damaged tires. In some cases, small punctures in the tread area may be repaired from within the removed tire by a Harley-Davidson dealer. Speed should NOT exceed 80 km/h (50 mph) for the first 24 hours after repair, and the repaired tire should NEVER be used over 129 km/h (80 mph). Failure to follow this warning could lead to tire failure and result in death or serious injury. (00015b)

⚠ WARNING

Do not exceed the motorcycle's Gross Vehicle Weight Rating (GVWR) or Gross Axle Weight Rating (GAWR). Exceeding these weight ratings can lead to component failure and adversely affect stability, handling and performance, which could result in death or serious injury. (00016f)

- GVWR is the sum of the weight of the motorcycle, accessories, and the maximum weight of the rider, passenger and cargo that can be safely carried.
- The GVWR is shown on the information plate, located on the frame steering head.

⚠ WARNING

Do not tow a disabled motorcycle. Towing can adversely affect stability and handling, which could result in death or serious injury. (00017a)

⚠ WARNING

Do not pull a trailer with a motorcycle. Pulling a trailer can cause tire overload, damage and failure, reduced braking performance, and adversely affect stability and handling, which could result in death or serious injury. (00018c)

⚠ CAUTION

Direct contact of DOT 5 brake fluid with eyes can cause eye irritation, swelling, and redness. Avoid eye contact. In case of eye contact flush with large amounts of water and get medical attention. Swallowing large amounts of DOT 5 brake fluid can cause digestive discomfort. If swallowed, obtain medical attention. Use in well ventilated area. **KEEP OUT OF REACH OF CHILDREN.** (00144b)

⚠ WARNING

Batteries, battery posts, terminals and related accessories contain lead and lead compounds, and other chemicals known to the State of California to cause cancer, and birth defects or other reproductive harm. Wash hands after handling. (00019e)

⚠ WARNING

Wheel weights on wheels without spokes contain lead and lead compounds, chemicals known to the State of California to cause cancer, and birth defects or other reproductive harm. (00356d)

⚠ WARNING

Consult a Harley-Davidson dealer regarding any questions or problems that occur in the operation of your motorcycle. Failure to do so can aggravate an initial problem, cause costly repairs, cause an accident and could result in death or serious injury. (00020a)

SERVICE

NOTICE

California vehicles, equipped with Evaporative Emission controls, have a plugged carburetor overflow fitting. The fuel supply valve on the vehicle should be turned off when the vehicle is not operating. Failure to do so may result in fuel drainage into the engine, dilution of the engine oil and engine damage. (00145a)

- Be sure all equipment required by federal, state and local law is installed and in good operating condition.

RULES OF THE ROAD

- Keep to the right side of the road centerline when meeting other vehicles coming in the opposite direction. Ride to left of center of your lane to avoid oily pavement ahead.
- Always sound your horn, actuate your turn signals, and exercise caution when passing other vehicles going in the same direction. Never try to pass another vehicle going in the same direction at street intersections, on curves, or when going up or down a hill.
- At street intersections give the right-of-way to the vehicle on your right. Do not presume you have the right-of-way, as the other driver may not know it is your turn.
- Always signal when preparing to stop, turn or pass.

- All traffic signs, including those used for the control of traffic at intersections, should be obeyed promptly. SLOW DOWN signs near schools and CAUTION signs at railroad crossings should always be observed and your actions governed accordingly.
- When intending to turn to the left, signal at least 100 feet (30.5 meters) before reaching the turning point. Move over to the centerline of the street (unless local rules require otherwise), slow down, enter the intersection of the street and then turn carefully to the left.
- Never anticipate a traffic light. When a change is indicated from GO to STOP (or vice versa) in the traffic control systems at intersections, slow down and wait for the light to change. Never run through a yellow or red traffic light.
- While turning either right or left, watch for pedestrians, animals, as well as vehicles.
- Do not leave the curb or parking area without signaling. Be sure your way is clear to enter moving traffic. A moving line of traffic always has the right-of-way.
- Be sure your license plate is installed in the position specified by law and is clearly visible at all times. Keep the plate clean.
- Ride at a safe speed that is consistent with the type of highway you are on. Pay strict attention to whether the road is dry, oily, icy or wet.

- Watch for debris such as leaves or loose gravel.
- Weather and traffic conditions on the highway dictate adjusting your speed and driving habits accordingly.

ACCESSORIES AND CARGO

Harley-Davidson Motor Company cannot test and make specific recommendations concerning every accessory or combination of accessories sold. Therefore, the rider must be responsible for safe operation of the motorcycle when installing accessories or carrying additional weight.

⚠ WARNING

See **ACCESSORIES AND CARGO** section within the **SAFETY FIRST** section in your owner's manual. Improper cargo loading or accessory installation can cause component failure and adversely affect stability, handling and performance, which could result in death or serious injury. (00021c)

⚠ WARNING

Do not exceed the motorcycle's Gross Vehicle Weight Rating (GVWR) or Gross Axle Weight Rating (GAWR). Exceeding these weight ratings can lead to component failure and adversely affect stability, handling and performance, which could result in death or serious injury. (00016f)

- GVWR is the sum of the weight of the motorcycle, accessories, and the maximum weight of the rider, passenger and cargo that can be safely carried.
- The GVWR is shown on the information plate which is located on the frame down tube.

⚠ WARNING

Do not pull a trailer with a motorcycle. Pulling a trailer can cause tire overload, damage and failure, reduced braking performance, and adversely affect stability and handling, which could result in death or serious injury. (00018c)

Accessory and Cargo Guidelines

The following guidelines should be used when equipping a motorcycle, carrying passengers and/or cargo.

⚠ WARNING

Travel at speeds appropriate for road and conditions and never travel faster than posted speed limit. Excessive speed can cause loss of vehicle control, which could result in death or serious injury. (00008a)

- Do not exceed the legal speed limit or drive too fast for existing conditions. Always reduce speed when poor driving conditions exist. High speed increases the influence of any other condition affecting stability and increases the possibility of loss of control.
- Pay strict attention to road surfaces and wind conditions. Any two wheeled vehicle may be subject to upsetting forces such as wind blasts from passing trucks, holes in the pavement, rough road surfaces, rider control error, etc. These forces may influence the handling characteristics of your motorcycle. If this happens, reduce speed and guide the motorcycle with a relaxed grip to a controlled condition. Do not brake abruptly or force the handlebar. This may aggravate an unstable condition.
- Keep cargo weight concentrated close to the motorcycle and as low as possible. This minimizes the change in the motorcycle's center of gravity.
- Distribute weight evenly on both sides of the vehicle.
- Do not load bulky items too far behind the rider or add weight to the handlebars or front forks.
- Do not exceed maximum specified load in each saddlebag.
- Luggage racks are designed for lightweight items. Do not overload racks.

- Be sure cargo is secure and will not shift while riding and recheck the cargo periodically. Accessories that change the operator's riding position may increase reaction time and affect handling of the motorcycle.
- Additional electrical equipment may overload the motorcycle's electrical system possibly resulting in electrical system and/or component failure.

⚠ WARNING

If Equipped: Front and/or rear guards are not intended to provide protection from bodily injury in a collision with another vehicle or any other object. (00022d)

Large surfaces such as fairings, windshields, back rests, and luggage racks can adversely affect handling. Only genuine Harley-Davidson items designed specifically for the motorcycle model should be used with proper installation.

⚠ WARNING

Harley-Davidson parts and accessories are designed for Harley-Davidson motorcycles. Using non-Harley-Davidson parts or accessories can adversely affect performance, stability or handling, which could result in death or serious injury. (00001b)

⚠ WARNING

Only Touring Harley-Davidson Motorcycles are suitable for sidecar use. Consult a Harley-Davidson dealer. Use of motorcycles other than Touring models with sidecars could result in death or serious injury. (00040a)



2005 SPORTSTER MODELS

This section provides left and right side views of your 2005 Sportster motorcycle. Please refer to the CONTROLS AND INDICATORS and OPERATION sections for specific details about each component.

NOTE

Specifications in this publication may not match those of official certification in some markets due to timing of publication printing, variance in testing methods, and/or vehicle differences. Customers seeking officially recognized regulatory specifications for their vehicle should refer to certification documents and/or contact their respective dealer or distributor.





- 1. Fuel supply valve
- 2. Enricher knob
- 3. Battery (under left side cover)
- 4. Fuse block holder
- 5. Rear master cylinder

- 6. Rear brake reservoir
- 7. Clutch inspection cover
- 8. Primary chain inspection cover
- 9. Engine oil filter

Figure 1. 2005 Sportster XL1200C Custom – Left Side View

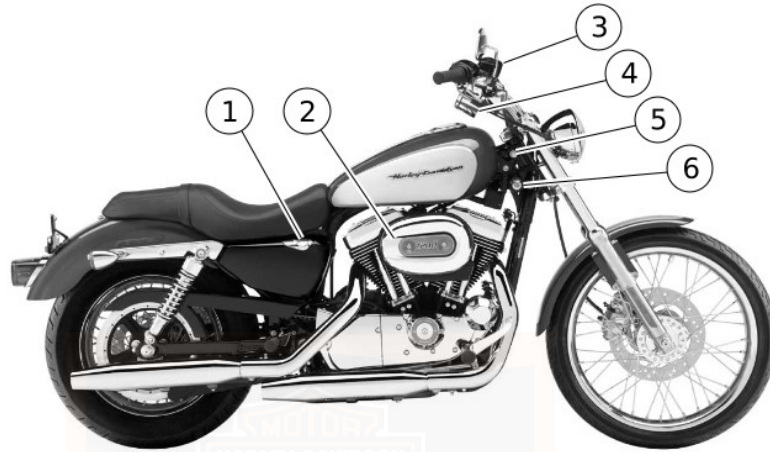

- | | |
|--|---------------------------------|
| 1. Engine oil fill plug and dipstick | 4. Speedometer |
| 2. Air cleaner | 5. Fork lock |
| 3. Front brake master cylinder and reservoir | 6. Ignition/headlamp key switch |

Figure 2. 2005 Sportster XL1200C Custom – Right Side View

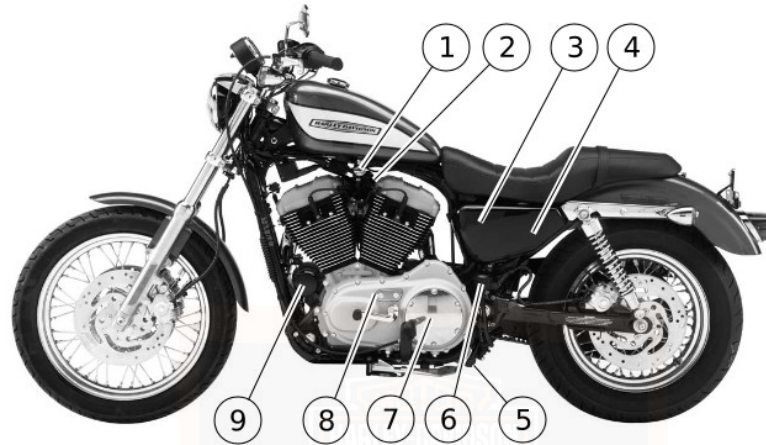

- | | |
|------------------------------------|-----------------------------------|
| 1. Fuel supply valve | 6. Rear brake reservoir |
| 2. Enrichener knob | 7. Clutch inspection cover |
| 3. Battery (under left side cover) | 8. Primary chain inspection cover |
| 4. Fuse block holder | 9. Engine oil filter |
| 5. Rear master cylinder | |

Figure 3. 2005 Sportster XL1200R Roadster – Left Side View

om00182



- | | |
|--|---------------------------------|
| 1. Engine oil fill plug and dipstick | 4. Speedometer |
| 2. Air cleaner | 5. Fork lock |
| 3. Front brake master cylinder and reservoir | 6. Ignition/headlamp key switch |

Figure 4. 2005 Sportster XL1200R Roadster – Right Side View

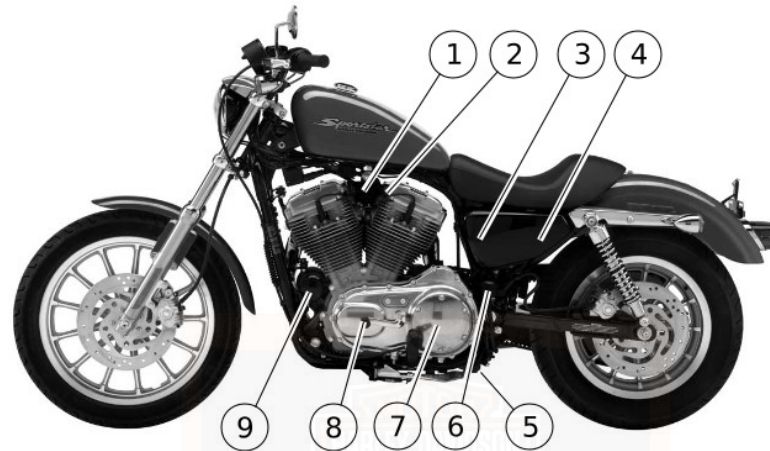

- | | |
|------------------------------------|-----------------------------------|
| 1. Fuel supply valve | 6. Rear brake reservoir |
| 2. Enricher knob | 7. Clutch inspection cover |
| 3. Battery (under left side cover) | 8. Primary chain inspection cover |
| 4. Fuse block holder | 9. Engine oil filter |
| 5. Rear master cylinder | |

Figure 5. 2005 Sportster XL883 – Left Side View



- | | |
|--|---------------------------------|
| 1. Engine oil fill plug and dipstick | 4. Speedometer |
| 2. Air cleaner | 5. Fork lock |
| 3. Front brake master cylinder and reservoir | 6. Ignition/headlamp key switch |

Figure 6. 2005 Sportster XL883 – Right Side View



- | | |
|------------------------------------|-----------------------------------|
| 1. Fuel supply valve | 6. Rear brake reservoir |
| 2. Enricher knob | 7. Clutch inspection cover |
| 3. Battery (under left side cover) | 8. Primary chain inspection cover |
| 4. Fuse block holder | 9. Engine oil filter |
| 5. Rear master cylinder | |

Figure 7. 2005 Sportster XL883R – Left Side View



- | | |
|--|---------------------------------|
| 1. Engine oil fill plug and dipstick | 4. Speedometer |
| 2. Air cleaner | 5. Fork lock |
| 3. Front brake master cylinder and reservoir | 6. Ignition/headlamp key switch |

Figure 8. 2005 Sportster XL883R – Right Side View



- | | |
|------------------------------------|-----------------------------------|
| 1. Fuel supply valve | 6. Rear brake reservoir |
| 2. Enrichener knob | 7. Clutch inspection cover |
| 3. Battery (under left side cover) | 8. Primary chain inspection cover |
| 4. Fuse block holder | 9. Engine oil filter |
| 5. Rear master cylinder | |

Figure 9. 2005 Sportster XL883C Custom – Left Side View



- | | |
|--|---------------------------------|
| 1. Engine oil fill plug and dipstick | 4. Speedometer |
| 2. Air cleaner | 5. Fork lock |
| 3. Front brake master cylinder and reservoir | 6. Ignition/headlamp key switch |

Figure 10. 2005 Sportster XL883C Custom – Right Side View

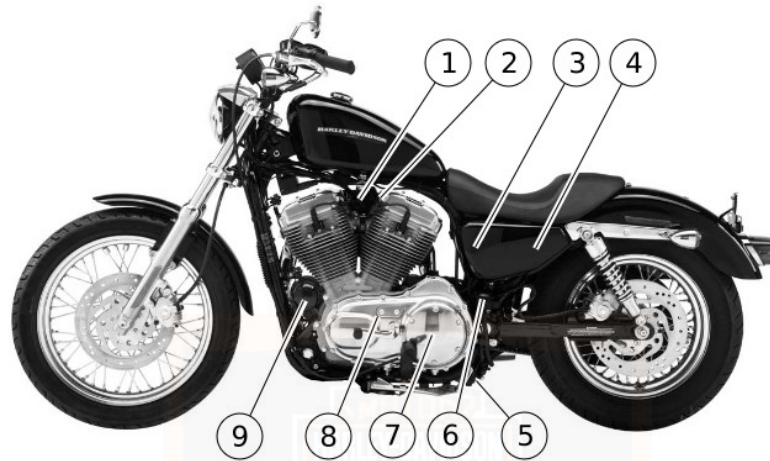

- | | |
|------------------------------------|-----------------------------------|
| 1. Fuel supply valve | 6. Rear brake reservoir |
| 2. Enrichener knob | 7. Clutch inspection cover |
| 3. Battery (under left side cover) | 8. Primary chain inspection cover |
| 4. Fuse block holder | 9. Engine oil filter |
| 5. Rear master cylinder | |

Figure 11. 2005 Sportster XL883 Low – Left Side View

om0018



- | | |
|--|---------------------------------|
| 1. Engine oil fill plug and dipstick | 4. Speedometer |
| 2. Air cleaner | 5. Fork lock |
| 3. Front brake master cylinder and reservoir | 6. Ignition/headlamp key switch |

Figure 12. 2005 Sportster XL883 Low – Right Side View

VEHICLE IDENTIFICATION NUMBER

See Figure 13. The full 17 digit serial or Vehicle Identification Number (V.I.N.) is stamped on the steering head and on a label located on the right front frame down tube.

An abbreviated V.I.N. is stamped on the left side crankcase at the base of the rear cylinder.

NOTE

Always give the full 17 digit Vehicle Identification Number when ordering parts or making any inquiry about your motorcycle.

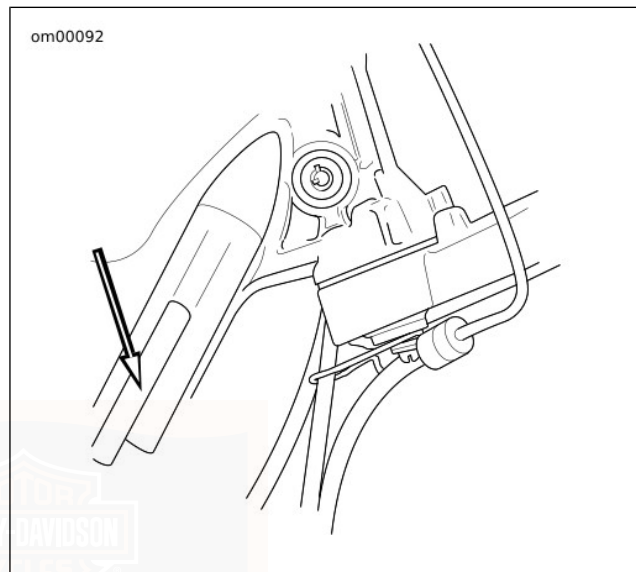
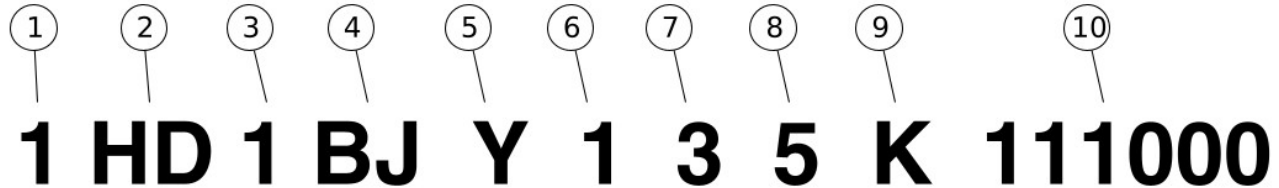

Figure 13. V.I.N. Stamping Location



- | | |
|-------------------------------------|--------------------------------------|
| 1. Market designation (1 character) | 6. Introduction date (1 character) |
| 2. Manufacturer (2 characters) | 7. V.I.N. check digit (1 character) |
| 3. Motorcycle type (1 character) | 8. Model year (1 character) |
| 4. Model (2 characters) | 9. Assembly plant (1 character) |
| 5. Engine type (1 character) | 10. Sequential number (6 characters) |

Figure 14. Typical Harley-Davidson Vehicle Identification Number

Table 3. 2005 Harley-Davidson General V.I.N. Breakdown

POSITION	DESCRIPTION	POSSIBLE VALUES
1	Market designation	1=Domestic 5=International
2	Manufacturer	HD=Harley-Davidson
3	Motorcycle type	1=Heavyweight motorcycle
4	Model	see model V.I.N. table

Table 3. 2005 Harley-Davidson General V.I.N. Breakdown

POSITION	DESCRIPTION	POSSIBLE VALUES
5	Engine type	Y=Carbureted B=Fuel injected
6	Introduction date	1=Regular 2=Mid-year 3=California
7	V.I.N. check digit	Can be 0-9 or X
8	Model year	5=2005
9	Assembly plant	Y=York, PA K=Kansas City, MO
10	Sequential number	varies

Table 4. 2005 Sportster V.I.N. Model Codes

CODE	MODEL NAME
CA	XL883
CJ	XL883C Custom
CM	XL883 Low

Table 4. 2005 Sportster V.I.N. Model Codes

CODE	MODEL NAME
CK	XL883R
CL	XL1200R Roadster
CG	XL1200C Custom

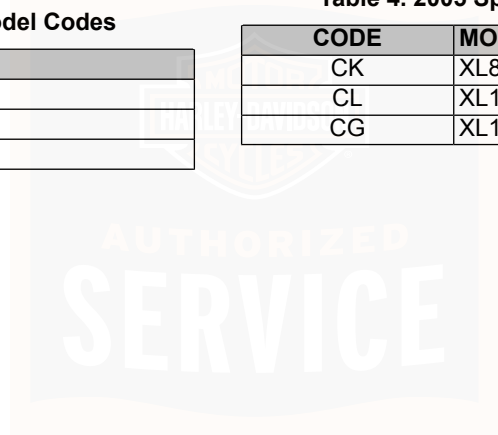

SPECIFICATIONS: 2005 SPORTSTER MODELS

Table 5. Ignition System: 2005 Sportster Models

COMPONENT	SPECIFICATION	
Ignition timing	not adjustable	
Battery	12 volt, 12 amp/hr, sealed and maintenance free	
Spark plug type	HD-6R12	
Spark plug size	12 mm	
Spark plug gap	0.97-1.09 mm	0.038-0.043 in.
Spark plug torque	16.3-24.4 N·m	12-18 ft-lbs

Table 6. Transmission Specifications

TRANSMISSION	SPECIFICATION
Type	Constant mesh, foot shift
Speeds	5 forward

Table 7. Engine: 2005 Sportster Models

ITEM	883 MODELS	1200 MODELS
Number of cylinders	2	
Type	4-cycle, 45 degree V-Type, air cooled	
Compression ratio	8.9-1	9.7-1
Bore	76.20 mm (3.00 in.)	88.85 mm (3.50 in.)
Stroke	96.82 mm (3.81 in.)	96.82 mm 3.81 in.
Displacement	883 cm ³ (53.86 in ³)	1200 cm ³ (73.20 in ³)
Torque	69.0 N·m (51.0 ft-lbs) @ 4300 RPM	107.0 N·m (79.0 ft-lbs) @ 3500 RPM

Table 8. Sprocket Teeth: 2005 Sportster Models

DRIVE	ITEM	NUMBER OF TEETH			
		883 MODELS		1200 MODELS	
		WORLD MODELS	U.S. MODELS	WORLD MODELS	U.S. MODELS
Primary	Engine	38	34	38	38
	Clutch	57	57	57	57

Table 8. Sprocket Teeth: 2005 Sportster Models

DRIVE	ITEM	NUMBER OF TEETH			
		883 MODELS		1200 MODELS	
		WORLD MODELS	U.S. MODELS	WORLD MODELS	U.S. MODELS
Final	Transmission	28	28	30	29
	Rear wheel	68	68	68	68

Table 9. Overall Gear Ratios: 2005 Sportster Models

GEAR	883 MODELS		1200 MODELS	
	WORLD MODELS	U.S. MODELS	WORLD MODELS	U.S. MODELS
1st	9.792	10.944	9.139	9.454
2nd	6.732	7.524	6.283	6.500
3rd	5.220	5.834	4.872	5.040
4th	4.301	4.806	4.014	4.152
5th	3.643	4.071	3.400	3.517

Table 10. Tire Sizes: 2005 Sportster Models

MODEL	MOUNT	SIZE	NUMBER
XL883, XL883 Low, XL883R, XL1200R	front	19 in.	D401F 100/90-19
XL883C, XL1200C	front	21 in.	D402F MH90-21
All	rear	16 in.	D401 150/80B16

Table 11. Tire Pressures: 2005 Sportster Models

MODEL	LOAD	TIRE PRESSURE (COLD)			
		FRONT		REAR	
		kPa	psi	kPa	psi
All	solo rider	206	30	248	36
	rider and passenger	206	30	275	40

2005 vehicles use Dunlop Harley-Davidson tires only.

Table 12. Bulb Chart: 2005 Sportster Models

LAMP	DESCRIPTION (ALL LAMPS 12 VOLT)	BULBS REQUIRED	CURRENT DRAW (AMPERAGE)	HARLEY-DAVIDSON PART NUMBER
Headlamp	high beam/low beam	1	4.58/5.0	68329-03
	position lamp international	1	0.32	53438-92
Tail and stop lamps	tail lamp	1	0.59	68167-04
	stop lamp	1	2.10	68167-88
	tail lamp international	1	0.59	68167-88
	stop lamp international	1	2.10	68167-88
Turn signal lamp	front/running	2	2.25/0.59	68168-89
	front international	2	1.75	68163-84
	rear	2	2.25	68572-64B
	rear international	2	1.75	68163-84
Instrument panel	Illuminated with LEDs. Replace entire assembly upon failure.			

Table 13. Dimensions: 2005 Sportster Models

ITEM	XL1200C CUSTOM		XL1200R ROADSTER		XL883 XL883R		XL883C CUSTOM		XL883 LOW	
	mm	in.	mm	in.	mm	in.	mm	in.	mm	in.
Wheel base	1534.2	60.4	1524	60.0	1524	60.0	1534.2	60.4	1524	60.0
Overall length	2293.6	90.3	2288.5	90.1	2288.5	90.1	2293.6	90.3	2288.5	90.1
Overall width	830.6	32.7	932.2	36.7	830.6	32.7	830.	32.76	830.6	32.7
Road clearance	111.8	4.4	141	5.6	141	5.6	111.8	4.4	111.8	4.4
Overall height	1160.8	45.7	1249.7	49.2	1137.9	44.8	1160.8	45.7	1137.	44.89
Saddle height	668	26.3	713.7	28.1	693.4	27.3	668	26.3	660.4	26.0

Table 14. Capacities: 2005 Sportster Models

ITEM	XL1200C CUSTOM		XL1200R ROADSTER		XL883 XL883R		XL883C CUSTOM		XL883 LOW	
	LITERS	U.S.	LITERS	U.S.	LITERS	U.S.	LITERS	U.S.	LITERS	U.S.
Fuel tank (total)	17.0	4.5 gal.	12.5	3.3 gal.	12.5	3.3 gal.	17.0	4.5 gal	12.5	3.3 gal.
Fuel tank (reserve)	3.8	1.0 gal.	3.0	0.8 gal.	3.0	0.8 gal.	3.8	1.0 gal.	3.0	0.8 gal.
Oil tank with filter	3.4	3.6 qt.	3.4	3.6 qt.	3.4	3.6 qt.	3.4	3.6 qt.	3.4	3.6 qt.
Transmission (approximate)	0.95	32 oz.	0.95	32 oz.	0.95	32 oz.	0.95	32 oz.	0.95	32 oz.

Table 15. Weights: 2005 Sportster Models

ITEM	XL1200C CUSTOM		XL1200R ROADSTER		XL883 XL883R		XL883C CUSTOM		XL883 LOW	
	kg	lb.	kg	lb.	kg	lb.	kg	lb.	kg	lb.
Weight (as shipped from factory)	261	575	262	577	261	574	263	579	261	574
GVWR	454	1000	454	1001	454	999	454	1001	454	999
GAWR front	149	329	152	335	152	335	152	335	152	335
GAWR rear	305	671	302	666	301	664	302	666	301	664

NOTE

Gross Vehicle Weight Rating GVWR (maximum allowable loaded vehicle weight) and corresponding Gross Axle Weight Ratings (GAWR) are given on a label located on the frame below the steering head.

TIRE DATA

▲ WARNING

Match tires, tubes, rim strips or seals, air valves and caps to the correct wheel. Contact a Harley-Davidson dealer. Mismatching can lead to tire damage, allow tire slippage on the wheel or cause tire failure, which could result in death or serious injury. (00023c)

▲ WARNING

Harley-Davidson recommends the use of its specified tires. Harley-Davidson vehicles are not designed for operation with non-specified tires, including snow, moped and other special-use tires. Use of non-specified tires can adversely affect stability, handling or braking and lead to loss of vehicle control, which could result in death or serious injury. (00024d)

Tubeless tires fitted with the correct size inner tubes may be used on all Harley-Davidson laced (wire spoked) wheels. Protective rubber rim strips must be used with tubeless tires (fitted with correct size inner tubes) when mounted on laced (wire spoked) wheels.

▲ WARNING

Use inner tubes on laced (wire spoked) wheels. Using tubeless tires on laced wheels can cause air leaks, which could result in death or serious injury. (00025b)

Tubeless tires are used on all Harley-Davidson cast and disc wheels.

Tire sizes are molded on the tire sidewall. Inner tube sizes are printed on the tube.

▲ WARNING

Harley-Davidson front and rear tires are not the same. Interchanging front and rear tires can cause tire failure, which could result in death or serious injury. (00026a)

▲ WARNING

Do not inflate tire beyond maximum pressure as specified on sidewall. Over inflated tires can blow out, which could result in death or serious injury. (00027b)

▲ WARNING

Replace tire immediately with a Harley-Davidson specified tire when wear bars become visible or only 1 mm (1/32 in) tread depth remains. Riding with a worn tire could result in death or serious injury. (00090c)

See SPECIFICATIONS > SPECIFICATIONS: 2005 SPORTSTER MODELS (Page 31) for tire pressures and sizes.

GASOLINE BLENDS

Your motorcycle was designed to get the best performance and efficiency using unleaded gasoline. Most gasoline is blended with alcohol and/or ether to create oxygenated blends. The type and amount of alcohol or ether added to the fuel is important.

NOTICE

Do not use gasoline that contains methanol. Doing so can result in fuel system component failure, engine damage and/or equipment malfunction. (00148a)

- Gasoline containing METHYL TERTIARY BUTYL ETHER (MTBE): Gasoline/MTBE blends are a mixture of gasoline and as much as 15% MTBE. Gasoline/MTBE blends can be used in your motorcycle.
- ETHANOL is a mixture of 10% ethanol (Grain alcohol) and 90% unleaded gasoline. Gasoline/ethanol blends can be used in your motorcycle if the ethanol content does **not** exceed 10%.

- **REFORMULATED OR OXYGENATED GASOLINES (RFG):** Reformulated gasoline is a term used to describe gasoline blends that are specifically designed to burn cleaner than other types of gasoline, leaving fewer tailpipe emissions. They are also formulated to evaporate less when you are filling your tank. Reformulated gasolines use additives to oxygenate the gas. Your motorcycle will run normally using this type of gas and Harley-Davidson recommends you use it when possible, as an aid to cleaner air in our environment.

You may find that some gasoline blends adversely affect the starting, driveability or fuel efficiency of your motorcycle. If you experience one or more of these problems, it is recommended you operate your motorcycle on straight unleaded gasoline.

FUEL

Refer to Table 16. Always use a good quality unleaded gasoline. Octane ratings are usually found on the pump.

⚠ WARNING

Avoid spills. Slowly open fuel filler cap. Do not fill above bottom of filler neck insert, leaving air space for fuel expansion. Secure filler cap after refueling. Gasoline is extremely flammable and highly explosive, which could result in death or serious injury. (00028b)

⚠ WARNING

Use care when refueling. Pressurized air in fuel tank can force gasoline to escape through filler tube. Gasoline is extremely flammable and highly explosive, which could result in death or serious injury. (00029a)

Modern service station pumps dispense a high flow of gasoline into a motorcycle fuel tank making air entrapment and pressurization a possibility.

Table 16. Octane Ratings: Sportster Models

VEHICLE	PUMP OCTANE (R + M)/2
883 Models	87 (91 RON)
1200 Models	91 (95 RON)

CATALYTIC CONVERTERS

California and all international motorcycles are equipped with catalytic converters.

NOTICE

Do not operate catalytic converter-equipped vehicle with engine misfire. If you operate the vehicle under this condition, the exhaust will become abnormally hot, which can cause vehicle damage, including emission control loss. (00149c)

NOTICE

Use only unleaded fuel in catalytic converter-equipped motorcycles. Using leaded fuel will damage the emission control system. (00150c)



GENERAL: CONTROLS AND INDICATORS

▲ WARNING

Identify and understand the specific features of your vehicle. Failure to understand how these features affect the vehicle's operation can lead to an accident, which could result in death or serious injury. (00043b)

Some features explained are unique to certain models. These features may be available as accessories for your Harley-Davidson motorcycle. See a Harley-Davidson dealer for a complete list of accessories that will fit your specific motorcycle.

Refer to the side view photographs in the front of the manual to locate the items discussed in this section. See IDENTIFICATION > 2005 SPORTSTER MODELS (Page 15).

IGNITION/HEADLAMP KEY SWITCH: SPORTSTER MODELS

▲ WARNING

The automatic-on headlamp feature provides increased visibility of the rider to other motorists. Be sure headlamp is on at all times. Poor visibility of rider to other motorists can result in death or serious injury. (00030b)

See Figure 15. The ignition/headlamp key switch controls electrical functions of the motorcycle.

See the YOUR OWNER'S MANUAL section at the front of this book. Be sure to record all your key numbers in the space provided.

NOTICE

Protect your vehicle against theft. Failure to lock the motorcycle after parking could result in theft and/or equipment damage. (00151b)

▲ WARNING

Do not operate vehicle with forks locked. Locking the forks restricts the vehicle's turning ability, which could result in death or serious injury. (00035a)

NOTICE

Do not lubricate barrel locks with petroleum based lubricants or graphite. Inoperative locks may result. (00152a)

NOTICE

Turn the ignition switch to the OFF position and remove the key before locking the motorcycle. Leaving the key in the ACC position will keep the instrument lights on and result in a discharged battery. (00155b)

Turn key counterclockwise to remove from the ignition. Refer to Table 17 for all key switch functions.

NOTE

- *ACC-Accessories and hazard warning flasher can be turned on. Instrument lamps are on. Brake lamp and horn can be activated. Key may not be removed.*
- *The lamps work when the switch is in the IGNITION position, as required by law in some localities.*

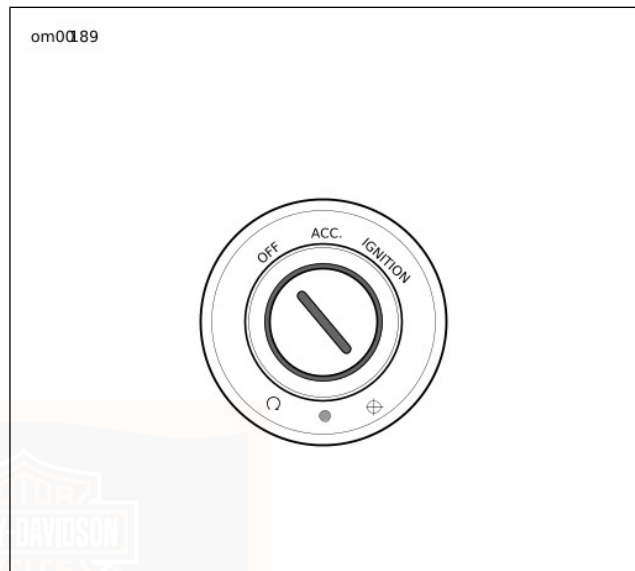

Figure 15. Ignition/Headlamp Key Switch: Sportster Models

Table 17. Ignition/Headlamp Switch Positions: 2005 Sportster Models

LOCATION AND OPERATION	SWITCH POSITION	FUNCTION
Switch is on right side of steering neck. Push in and turn key to operate.	OFF	Ignition and lamps are off. Key may be removed.
	ACC*	Accessories and hazard warning flasher can be turned on. Instrument lamps are on. Brake lamp and horn can be activated. Key may be removed except for international models.
	IGNITION*	Ignition and lamps are on.
*International models have an additional function – position lamp and tail lamp are also on.		

HAND CONTROLS: BASIC OPERATION

Electric Starter Switch

NOTE

Off/Run switch MUST be in RUN position to operate engine.

See Figure 16. The electric starter switch is located on the right handlebar control group. See OPERATION > STARTING THE ENGINE: CARBURETED MODELS (Page 82) for detailed operation procedures.

1. Put the engine off/run switch in the RUN position and the transmission in neutral. Neutral (green) indicator lamp should be illuminated.
2. See Figure 15. Turn ignition/headlamp key switch to ON and push the START switch to operate starter motor.

Engine OFF/RUN Switch

See Figure 16. The engine off/run switch (7) turns the ignition power ON or OFF. The engine off/run switch is located on the right handlebar control. Push the top portion of the engine off/run switch to turn off ignition power and shut the engine off. Push the bottom portion of the engine off/run switch to turn on ignition power.

NOTE

- *The engine off/run switch must be in the ON position to start or operate the engine.*
 - *The engine off/run switch should be used to shut the engine off.*
1. To shut the engine off, push the top of the off/run switch to the ignition OFF position.

2. See Figure 15. Turn the ignition key to the OFF position to turn the ignition power completely OFF.

Throttle Control Grip

See Figure 16. The throttle control grip (9) is located on the right handlebar control and is operated with the right hand.

To reduce rider fatigue on long trips, a spring loaded throttle friction adjustment screw (10) is located at the bottom of the throttle grip clamp on non-cruise equipped models.

1. Slowly turn throttle control grip clockwise (toward the front of the bike) to close the throttle (decelerate).
2. Slowly turn throttle control grip counterclockwise (toward rear of bike) to open the throttle (accelerate).

⚠ WARNING

Do not tighten throttle friction adjustment screw to the point where the engine will not return to idle automatically. Over-tightening can lead to loss of vehicle control, which could result in death or serious injury. (00031b)

3. Unscrew the throttle friction adjustment screw so the throttle returns to the idle position when the hand is removed from the grip.

4. Screw the throttle adjustment screw in to increase friction on grip. This provides a damping effect on throttle motion.

NOTE

The throttle friction adjustment screw should not be used under normal stop and go operating conditions.

Clutch Hand Lever

⚠ WARNING

Do not position fingers between hand control lever and handlebar grip. Improper hand positioning can impair control lever operation and cause loss of vehicle control, which could result in death or serious injury. (00032a)

The clutch hand lever (1) is located on the left handlebar and is operated with the fingers of the left hand.

1. Slowly pull clutch hand lever in against handlebar grip to fully disengage clutch.
2. Shift to first gear using the gear shifter lever. See OPERATION > SHIFTING GEARS (Page 84).
3. Slowly release the clutch hand lever to engage clutch.

Horn Switch

The horn is operated by pushing on the horn switch (2) located on the left handlebar control group.

Headlamp Dimmer Switch

The headlamp dimmer switch (3) is located on the left handlebar. The switch has two positions to activate the headlamps high or low beams.

- Press the top of the headlamp dimmer beam switch to activate the high beam.
- Press the bottom of the headlamp dimmer switch to return to the low beam.

See Figure 17. The (blue) high beam indicator lamp will illuminate when the high beam is on.

Turn Signal Switches

Each handlebar control group contains a turn signal switch.

- The right turn signal switch (11) operates the right front and right rear flashing lamps.
- The left turn signal switch (4) operates the left front and left rear flashing lamps.

NOTE

Front turn signal lamps also function as running lamps.



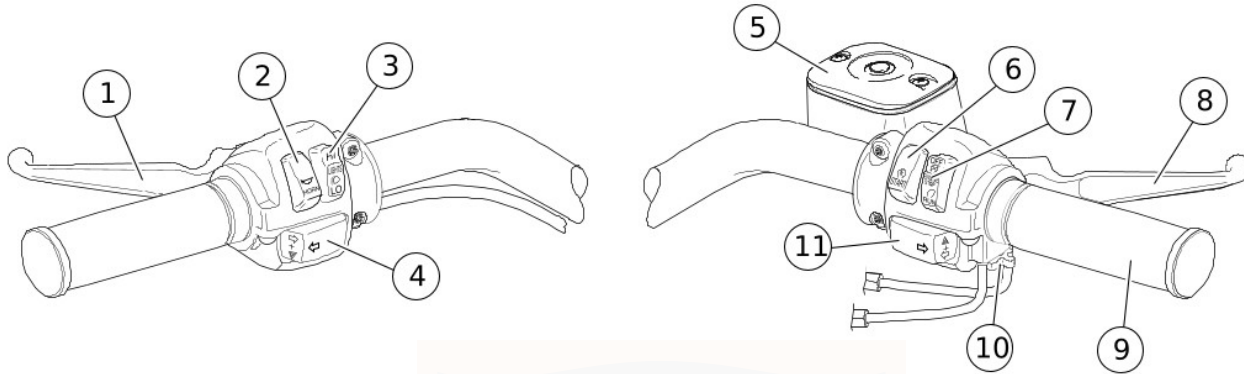

1. Clutch hand lever
2. Horn switch
3. Headlamp dimmer switch
4. Left turn signal switch
5. Master cylinder reservoir
6. Electric starter switch

7. Engine off/run switch
8. Brake hand lever
9. Throttle control grip
10. Throttle friction adjusting screw
11. Right turn signal switch

Figure 16. Handlebar Controls

TURN SIGNAL SWITCH OPERATION

The turn signal switches are used by the turn signal module to control turn signal operation based on vehicle speed, vehicle acceleration and turn completion.

Momentarily depress the desired turn signal switch. The turn signal lamps will begin and continue flashing until they are manually or automatically cancelled. As long as the motorcycle is stationary, the signals will flash.

NOTE

- If you want the turn signals on longer, hold the switch in. The turn signals will begin flashing immediately, but the microprocessor will not begin computing distance until you release the switch.
- If you are signaling to turn in one direction and you depress the switch for the opposite turn signal, the first signal is cancelled and the opposite side begins flashing.
- If you want to stop the lamps from flashing, briefly depress the turn signal switch a second time. The turn signal lamps will stop flashing.

HAZARD WARNING 4-WAY FLASHER

Use the following method to activate the four-way flashers.

1. With the ignition key ON and security system disarmed (models with security only), press the left and right turn signal switches at the same time.
2. Turn the ignition key OFF and arm the security system if present and desired. The four-way flashers will continue for two hours.
3. To cancel four-way flashing, disarm the security system if necessary, turn the ignition key ON and press the left and right turn signal switches at the same time.

This system allows a stranded vehicle to be left in the four-way flashing mode and secured until help is found.

INDICATOR LAMPS

See Figure 17. Five indicator lamps are provided.

- The green TURN indicators will flash when turn signals are activated; therefore, flashing indicates the chosen turn direction. When the 4-way hazard flashers are operating, both turn indicators will flash simultaneously.
- The blue BEAM indicator lamp, when lit, signals high beam headlamp operation.
- The green NEUTRAL lamp, when lit, signals the transmission is in neutral gear.
- The red OIL indicator lamp, when lit, signals that oil is not circulating through the engine.

NOTE

The OIL indicator lamp will glow when the ignition is turned on prior to starting engine. With engine running, lamp should be off when engine speed is above idle.

Several other circumstances that could cause the red oil indicator lamp to signal, include the following:

- If the oil pressure indicator lamp does not go off at speeds above idling, it is usually because of an empty oil tank or diluted oil.

- In freezing weather the oil feed may clog with ice and sludge, preventing oil circulation.
- A grounded oil signal switch wire.
- A faulty signal switch.
- A damaged or improperly installed check valve.
- Trouble with the pump.

NOTICE

If the oil pressure indicator lamp remains lit, always check the oil supply first. If the oil supply is normal and the lamp is still lit, stop the engine at once and do not ride further until the trouble is located and the necessary repairs are made. Failure to do so may result in engine damage. (00157a)

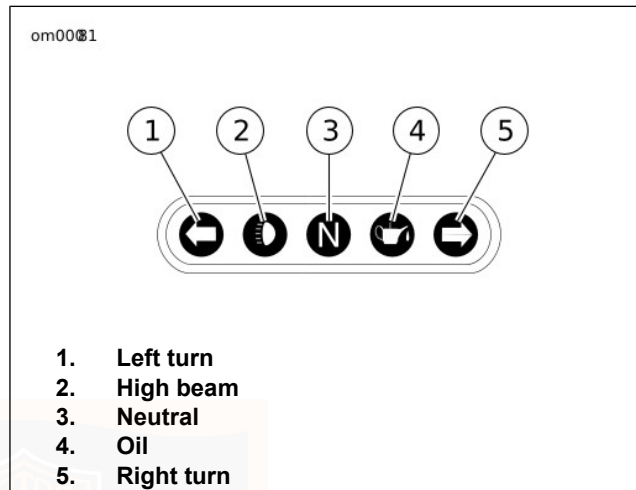

Figure 17. Indicator Lamps

INSTRUMENTS: SPORTSTER MODELS

Speedometer

⚠ WARNING

Travel at speeds appropriate for road and conditions and never travel faster than posted speed limit. Excessive speed can cause loss of vehicle control, which could result in death or serious injury. (00008a)

See Figure 18. The speedometer registers miles per hour (U.S. models only) or kilometers per hour (international models only) of forward speed. The odometer registers the number of miles/kilometers the vehicle has traveled.

The electronic speedometer has a single display window for both the odometer and trip-odometer.

1. Press the function switch to change the display window on the speedometer face to either odometer or trip-odometer.
2. To reset the trip-odometer to zero, press button to reset speedometer display to the ODOMETER mode and hold the button in for approximately 2-3 seconds. The speedometer will switch to the trip-odometer mode and reset the display to zero.

Tachometer

NOTICE

See OPERATING RECOMMENDATIONS section. Do not operate the engine above maximum safe RPM as shown under OPERATION (red zone on tachometer). Lower the RPM by upshifting to a higher gear or reducing the amount of throttle. Failure to lower RPM may cause equipment damage. (00159a)

The tachometer (if applicable) registers the engine speed in revolutions per minute (RPM).

Trip Odometer

Use the trip-odometer A or trip-odometer B to register number of miles/kilometers traveled on a trip or between refueling.

Odometer will display mileage when bike is OFF when function switch is pressed. There is no need to turn the bike on to check the odometer reading.

NOTICE

Never attempt to tamper with or alter the vehicle odometer. This is illegal. Tampering with or altering a vehicle odometer may cause equipment damage. (00160a)

Tip Indicator Lamp

⚠ WARNING

If tip occurs, check all controls for proper operation. Restricted control movement can adversely affect the performance of the brakes, clutch or ability to shift, which could result in loss of vehicle control and death or serious injury. (00350a)

Should motorcycle be tipped over, the word "tip" will appear in the odometer window. Engine will not start until reset. To reset, cycle ignition/headlamp key switch ON-OFF-ON.

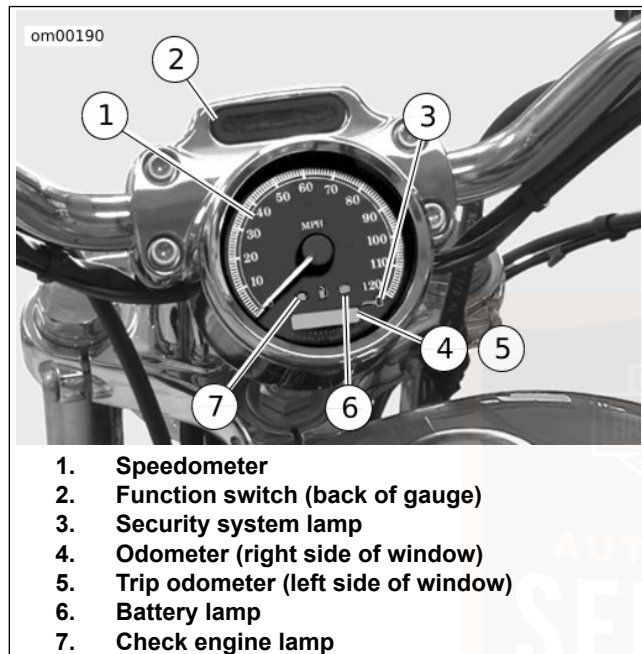

Figure 18. Speedometer/Odometer: Sportster Models (1200 Custom)

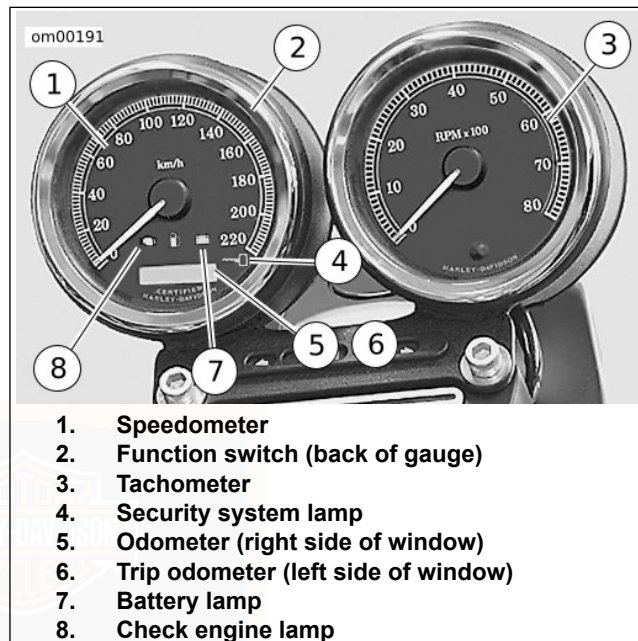

Figure 19. Speedometer/Odometer and Tachometer: International Sportster Models (1200R Roadster)

ENRICHENER

Carbureted Models Only

A constant velocity (C.V.) carburetor uses an enrichener instead of a choke. An enrichener is operated almost the same way as a choke except there are two differences:

- When starting a cold engine, the throttle control **MUST BE CLOSED** for the enrichener to work properly.
- The enrichener does not have detents. The enrichener knob position can be adjusted from full-in to full-out.

See Figure 20. Engine speed increases as the enrichener knob is pulled out. By moving the enrichener knob, you adjust the air/fuel mixture to start a cold or warm engine.

1. Pull enrichener knob all the way out for cold engine starting.

NOTICE

Pay close attention to the vehicle's warm-up time. Either excessive or insufficient use of the enrichener may cause poor performance, erratic idle, poor fuel economy, spark plug fouling and equipment damage. (00164a)

2. Change the enrichener knob position between full-out or full-in as the situation requires.

NOTE

See *OPERATION* section for detailed starting procedures.

Only carbureted models use an enrichener.

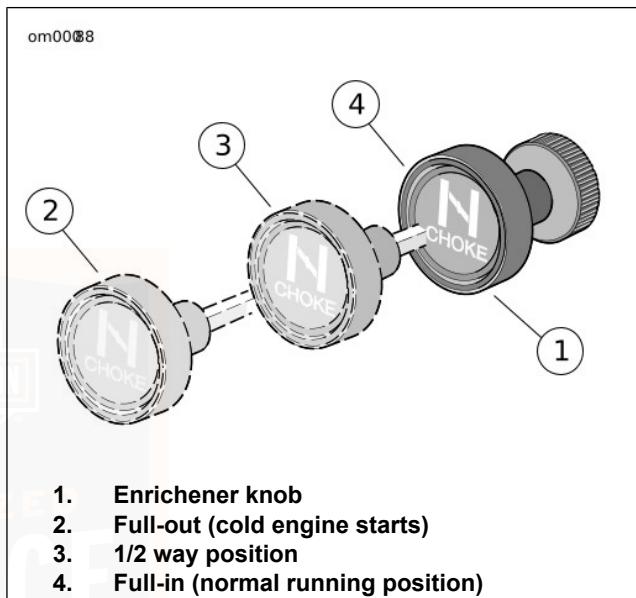

Figure 20. Setting the Enrichener

GEAR SHIFT LEVER

NOTICE

The clutch must be fully disengaged before attempting a gear shift. Failure to fully disengage the clutch can result in equipment damage. (00182a)

The gear shift lever is located on the left side of the motorcycle and is operated with the left foot.

1. Push the gear shift lever all the way down (full stroke) to shift the transmission to the next lower gear.
2. Lift the gear shift lever all the way up (full stroke) to shift the transmission to the next higher gear.

NOTE

- *Release the gear shift lever after each gear change.*
- *The lever must return to its central position before another gear change can be made.*

See Figure 21. First gear is the last gear position that can be found by pushing the gear shift lever full stroke downward.

Neutral is located between first and second gear. The green neutral indicator lamp on the dash will illuminate when the transmission is in neutral.

1. To shift from first gear to neutral, lift the gear shift lever 1/2 of its full stroke.
2. To shift from second gear to neutral, push the gear shift lever downward 1/2 of its full stroke.

When the motorcycle is standing still and the engine is not running, shifting gears requires a different technique. Before shifting in this condition, move the motorcycle backward and forward with the clutch fully disengaged (clutch lever pulled in). While maintaining slight pressure on the shift lever, shift from one gear to another.

Even with the engine running and the motorcycle standing still, difficulty may be experienced in shifting gears. This difficulty occurs because transmission gears are not turning and shifting parts are not lined up to permit engagement.

NOTICE

When difficulty of shifting gears is experienced, do not under any circumstances, attempt to force the shift. The results of such abuse will be a damaged or broken shifter mechanism. (00161a)

See OPERATION > SHIFTING GEARS (Page 84) for more information.

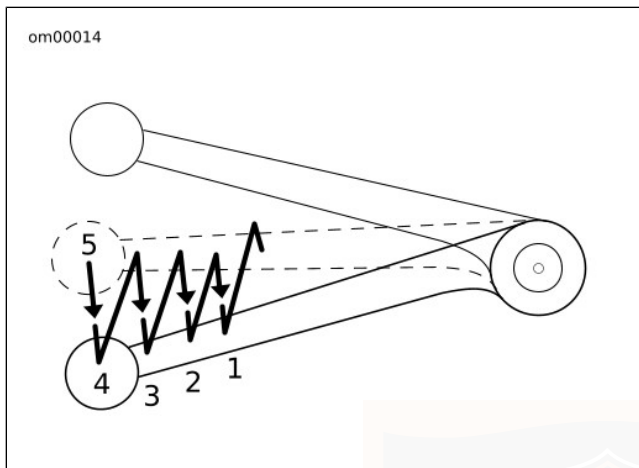

Figure 21. Shifting Sequence: Downshift

BRAKE SYSTEM

⚠ WARNING

Do not apply brake strongly enough to lock the wheel. A locked wheel will skid and can cause loss of vehicle control, which could result in death or serious injury. (00053a)

The rear brake pedal controls the rear wheel brake and is located on the motorcycle's right side. Operate the rear brake pedal with the right foot.

The front brake hand lever controls the front wheel brake and is located on the right handlebar. Operate the hand lever with the fingers of the right hand.

⚠ WARNING

Do not position fingers between hand control lever and handlebar grip. Improper hand positioning can impair control lever operation and cause loss of vehicle control, which could result in death or serious injury. (00032a)

Brakes should be applied uniformly and evenly to prevent wheels from locking up. A balance between rear and front braking is generally best.

JIFFY STAND

⚠ WARNING

Always park motorcycle on a level, firm surface. An unbalanced motorcycle can fall over, which could result in death or serious injury. (00039a)

See Figure 22. The jiffy stand is located on the left side of the motorcycle and swings outward to support the motorcycle for parking.

⚠ WARNING

The jiffy stand locks when placed in the full forward (down) position with vehicle weight on it. If the jiffy stand is not in the full forward (down) position with vehicle weight on it, the vehicle can fall over which could result in death or serious injury. (00006a)

⚠ WARNING

Be sure jiffy stand is fully retracted before riding. If jiffy stand is not fully retracted, it can contact the road surface causing a loss of vehicle control, which could result in death or serious injury. (00007a)

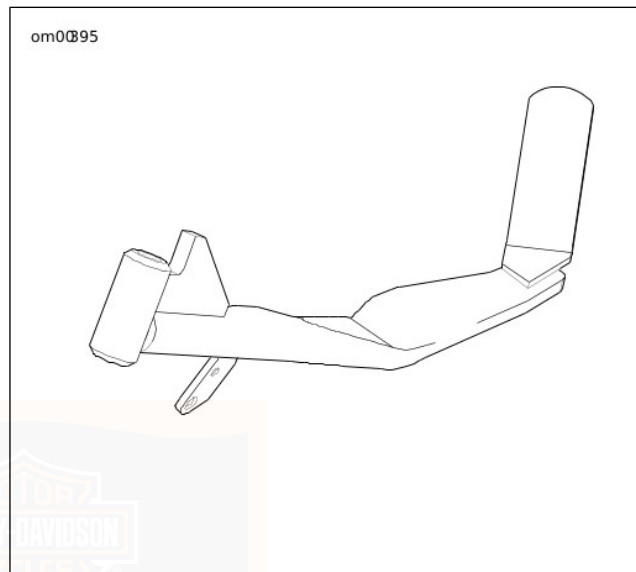

Figure 22. Jiffy Stand: Sportster Models

REAR VIEW MIRRORS

⚠ WARNING

Objects in mirrors are closer than they appear. Use caution when judging distance of objects in mirrors. Failure to judge correct distances could result in death or serious injury. (00033a)

Your vehicle is equipped with two convex rear view mirrors.

This type of mirror is designed to give a much wider view to the rear than a flat mirror. However, cars and other objects seen in this type of mirror will look smaller and farther away than when seen in a flat mirror.

- Use caution when judging the size or relative distance of objects seen in rear view mirrors.
- Always adjust the rear view mirrors to clearly reflect the area behind the motorcycle before riding.

NOTE

Adjust mirrors so you can see a small portion of your shoulders in each mirror. This will help you establish the relative distance of vehicles to the rear of your motorcycle.

FUEL SUPPLY VALVE

Carbureted Models Only

See Figure 23. The fuel supply valve is located under the fuel tank. The fuel supply is cut off to the engine when the valve handle is horizontal and when the engine is turned OFF.

1. Turn the handle to the horizontal position (2) to turn OFF main fuel supply.
2. Turn handle to position (3) to turn ON main fuel supply.

3. Turn the handle to position (1) to turn ON reserve fuel supply.

The fuel supply valve is vacuum-operated and will open and close when engine is turned ON or OFF.

NOTE

- *The fuel supply valve on the vehicle should be turned OFF when the vehicle is not operating.*
- *To always maintain a reserve supply, do not operate the motorcycle with the valve in the reserve (RES) position after refueling.*

om0000

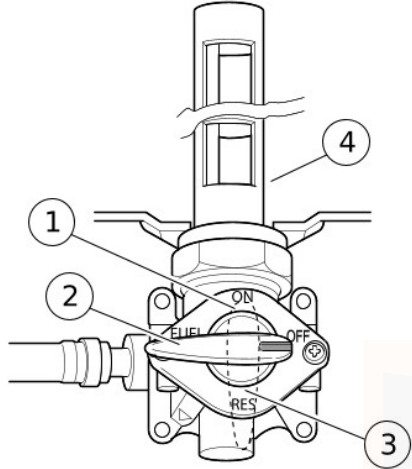

1. Handle UP (reserve supply) – ON position
2. Handle HORIZONTAL – OFF position
3. Handle DOWN (main supply) – ON position
4. Fuel strainer

Figure 23. Fuel Supply Valve

FUEL FILLER CAP: SPORTSTER MODELS

See Figure 24. To open, turn fuel filler cap counterclockwise and lift up. To close, turn fuel filler cap clockwise until it clicks. The ratchet action of the cap prevents overtightening.

NOTE

Fuel filler cap turns approximately a 3/4 turn before it starts unscrewing.

See SAFE OPERATING RULES section and review safety procedures listed below.

NOTICE

Do not spill fuel onto the motorcycle while refueling. Immediately wipe up fuel spills on your motorcycle. Fuel can cause damage to cosmetic surfaces. (00147b)

NOTICE

Use only unleaded fuel in catalytic converter-equipped motorcycles. Using leaded fuel will damage the emission control system. (00150c)

⚠ WARNING

Do not store motorcycle with gasoline in tank within the home or garage where open flames, pilot lights, sparks or electric motors are present. Gasoline is extremely flammable and highly explosive, which could result in death or serious injury. (00003a)

⚠ WARNING

Avoid spills. Slowly open fuel filler cap. Do not fill above bottom of filler neck insert, leaving air space for fuel expansion. Secure filler cap after refueling. Gasoline is extremely flammable and highly explosive, which could result in death or serious injury. (00028b)

⚠ WARNING

Do not use aftermarket fuel caps. Aftermarket fuel caps may fit improperly and leak, which could lead to death or serious injury. See a Harley-Davidson dealer for approved fuel caps. (00034a)

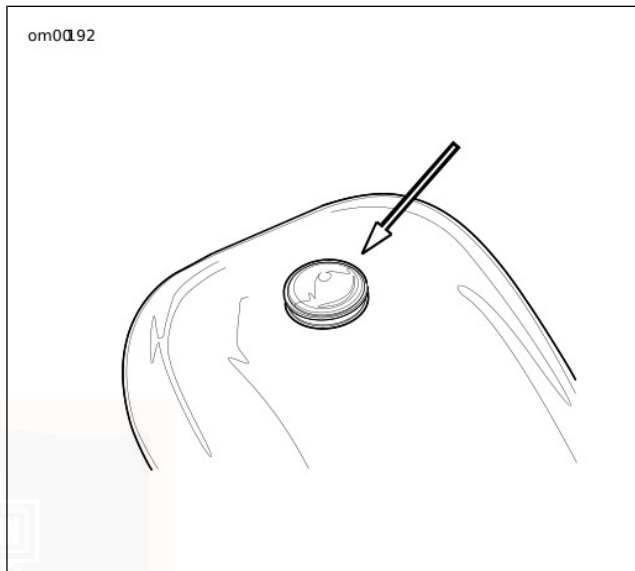

Figure 24. Fuel Filler Cap: Sportster Models
FORK LOCK: SPORTSTER MODELS

NOTICE

Protect your vehicle against theft. Failure to lock the motorcycle after parking could result in theft and/or equipment damage. (00151b)

See Figure 25. Sportster models have the fork lock located on the steering head just above the ignition/headlamp key switch. Using the fork lock immediately after parking your motorcycle will discourage unauthorized use or theft when parking your motorcycle.

⚠ WARNING

Do not operate vehicle with forks locked. Locking the forks restricts the vehicle's turning ability, which could result in death or serious injury. (00035a)

To lock fork, see Figure 26.

1. Turn fork to full left position.
2. Insert ignition key into fork lock.
3. Turn to right position (clockwise).
4. Remove ignition key.

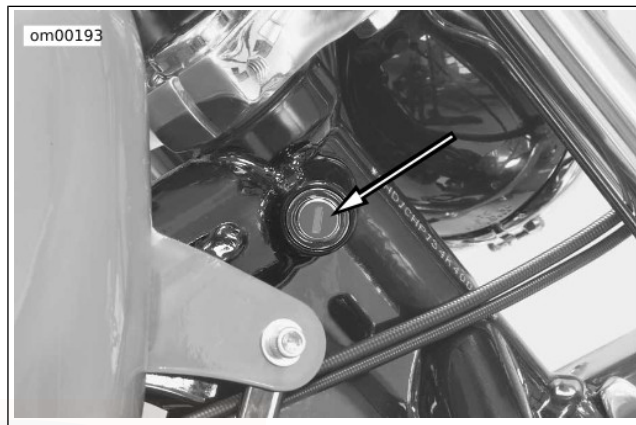

Figure 25. Fork Lock Location: Sportster Models

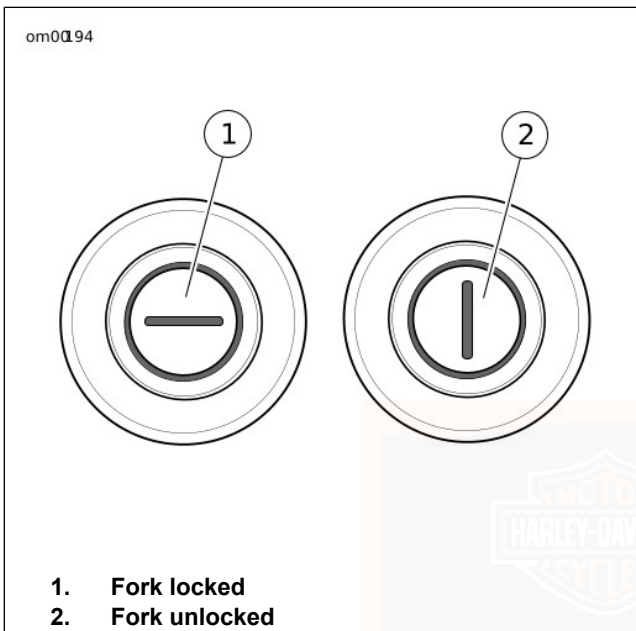

Figure 26. Fork Lock Positions: Sportster Models

SHOCK ABSORBERS: SPORTSTER MODELS

Rear Shock Preload Adjustment (All Models)

⚠ WARNING

Adjust both shock absorbers equally. Improper adjustment can adversely affect stability and handling, which could result in death or serious injury. (00036b)

See Figure 27. The Sportster models feature rear shock absorbers that can be adjusted for carrying the weight of a rider and/or passenger.

NOTE

- *XL Custom models have five preload positions.*
- *XL 883 and XL Roadster models have three preload positions.*

See Figure 28 and Figure 29. To adjust the rear shock spring preload, turn spring adjusting cam to the desired position with a spanner wrench. When reducing preload, cams should be rotated in opposite direction. A SPANNER WRENCH (PART NUMBER: HD-94820-75A) is available from your Harley-Davidson dealer.

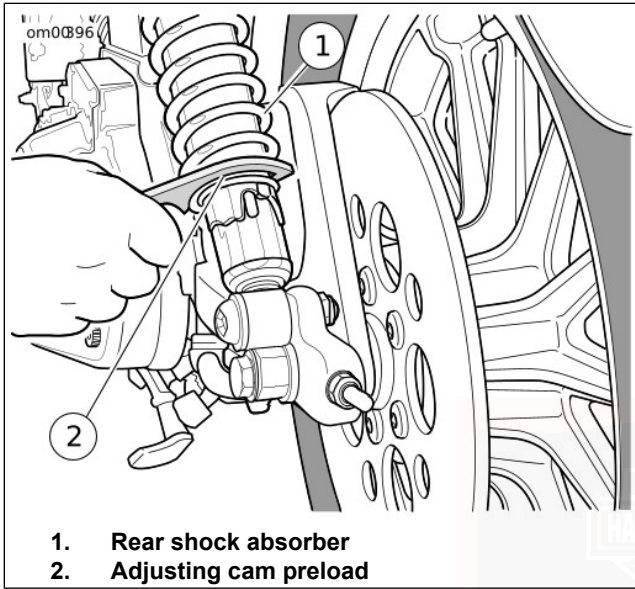

Figure 27. Rear Shock Absorber Adjustment: Sportster Models

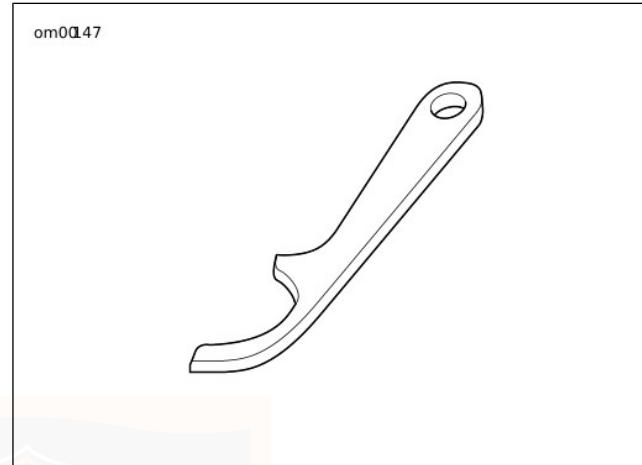
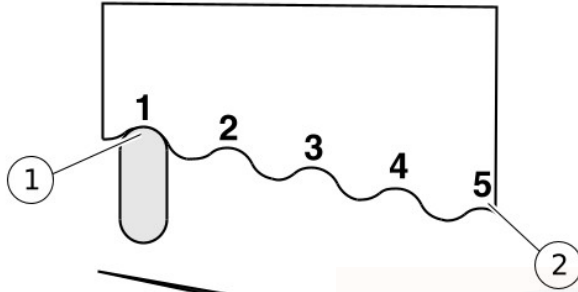

Figure 28. Spanner Wrench

om0096



1. Minimum preload adjustment
2. Maximum preload adjustment

Figure 29. Preload Adjustment: Sportster Models

NOTES



BASIC SECURITY SYSTEM OPERATION

The security system provides security and immobilization functions. The security system will disable the starter and the ignition or EFI system. Additional functions include the ability to flash all four turn signals and sound a siren (if purchased as an option) if a theft attempt is detected.

Conditions that activate the security alarm when the system is armed include:

- Detecting vehicle movement.
- Detecting tampering of the ignition switch circuit.
- Detecting tampering of the security lamp circuit.
- Detecting that a battery disconnect has occurred while armed. (Activates siren only if P&A siren is installed.)

SECURITY SYSTEM OPTIONS

The following configurations are available on the security system unit:

- Alarm sensitivity.
- Auto-arming feature.
- Storage mode.

Factory settings for the security system include:

- Medium motion alarm sensitivity.

- Key fob arming mode.
- Storage mode set to 10 days.

FCC REGULATIONS

This device complies with Part 15 of the FCC Rules and with RSS-210 of Industry Canada rules.

Operation is subject to the following conditions:

- This device may not cause harmful interference.
- This device must accept any interference received, including interference that may cause undesired operation.

ARMING THE SYSTEM

There are two methods to arm the security system:

- **Remote-arming:** See Figure 30. Owners may enable security alarm and immobilization functions with a remote, personally carried transmitter. This transmitter is referred to as a key fob within this document.
- **Auto-arming:** Arms the security system within 30 seconds after IGNITION switch is turned OFF. To enable auto-arming see Using Auto-arming below.

NOTE

- *The vehicle cannot be armed with the engine running or the ignition ON.*

- *International vehicles are configured for auto-arming. This cannot be changed.*

Using Key Fob

See Figure 30. Hold down the key fob button until the system responds with two turn signal flashes and two chirps from optional siren. To assign a key fob to a motorcycle, refer to Table 21.

Using Auto-arming

Auto-arming causes the security system to automatically arm itself (without the use of the key fob) within 30 seconds after the ignition key is turned OFF. During this period, the security lamp stays on solid to indicate auto-arming is starting up.

The vehicle may be moved during these 30 seconds without triggering the alarm. However, any motion after that period will trigger the security alarm. Upon expiration of the auto-arming period, the turn signals flash twice, the security lamp begins to flash and the siren (if installed) chirps twice.

To set the auto-arming selection, refer to Table 23.

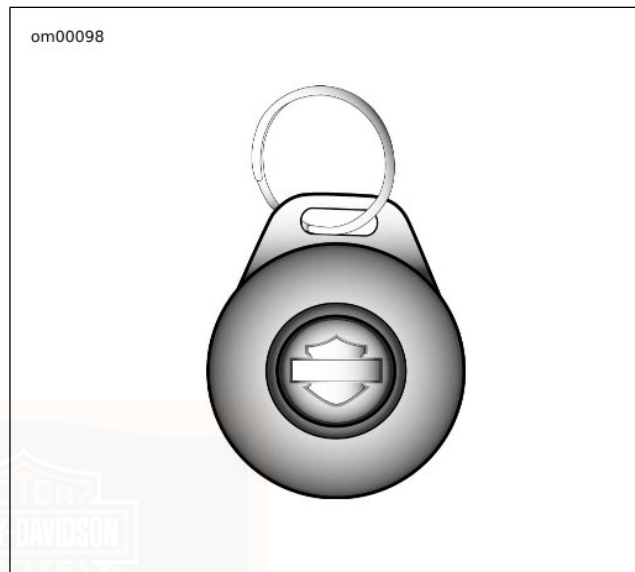

Figure 30. Key Fob

DISARMING THE SYSTEM

There are two ways to disarm the system:

- **Remote disarming:** See Figure 30. Owners may disable security alarm and immobilization functions with a remote, personally carried transmitter. This transmitter is referred to as a key fob within this document.

- **Personal code:** If a key fob is not available, the security system allows the rider to disable the security alarm and immobilization functions if the rider knows the previously entered personal code.

NOTE

Do not forget to enter a personal code for security system vehicles. If a code is not assigned and the key fob is lost or damaged while the vehicle is armed, the security system module must be replaced. Refer to Table 22 for personal code setup.

Using Key Fob

See Figure 30. Quickly press the key fob button twice. The system will respond with one turn signal flash.

NOTE

- **Disarming function may require practice.** *The key fob button must be pressed twice within 1.5 seconds to send the disarm command. The action is very similar to double-clicking a computer mouse. Light quick taps work best; very hard or very slow taps are less likely to work.*

- *If the system is remotely disarmed (with the key fob) but the ignition key is not turned ON within 30 seconds, the system will rearm itself when auto-arming is enabled.*

Using Personal Code

Enter the five digit personal code you have chosen using the left and right turn signal switches. For complete procedure refer to Table 18. To create a personal code, refer to Table 22.

NOTE

If you make an error while disarming the security system using the personal code, the alarm will activate for 30 seconds after the last digit is entered. After a failed attempt, the security lamp will flash once every second for 10 minutes. During this time, the vehicle will not accept any attempt to enter a personal code.

Table 18. Entering a Personal Code to Disarm Security System

STEP NO.	ACTION	WAIT FOR CONFIRMATION	NOTES
<i>NOTE: The left turn signal switch is used for code number entry and the right turn signal is used as the "enter" key.</i>			
1	Know your 5 digit personal code		
2	Turn IGN key to ACC		
3	Hold both turn switches in until confirmation	Security lamp blinks at fast rate	
4	Enter first digit of code (a) by pressing left turn switch a times		
5	Press right turn switch 1 time		Serves as enter key for first digit
6	Enter second digit of code (b) by pressing left turn switch b times		
7	Press right turn switch 1 time		Serves as enter key for second digit
8	Enter third digit of code (c) by pressing left turn switch c times		
9	Press right turn switch 1 time		Serves as enter key for third digit
10	Enter fourth digit of code (d) by pressing left turn switch d times		
11	Press right turn switch 1 time		Serves as enter key for fourth digit
12	Enter fifth digit of code (e) by pressing left turn switch e times		
13	Press right turn switch 1 time	Security lamp stops blinking	System is disarmed. You may use the vehicle or program another key fob.

SECURITY STATUS LAMP

See Figure 31. A lamp within the speedometer face tells the rider if the system is armed or disarmed.

Refer to Table 19 for an explanation of the lamp's activity.

Table 19. Security Lamp Status

SECURITY LAMP STATUS	MODE
Does not flash.	No security system (TSSM), security system not armed or storage mode active.
Flashes every second.	10 minute time-out after failed personal code entry attempt.
Flashes every 2 seconds.	Security system armed.
Flashes 3 times a second.	Personal code entry mode.
Stays ON solid with ignition key OFF.	Auto-arming is started up. You have 30 seconds before system armed.
Stays ON solid with ignition key ON.	If solid for more than 8 seconds after key is ON, a current trouble code is present.

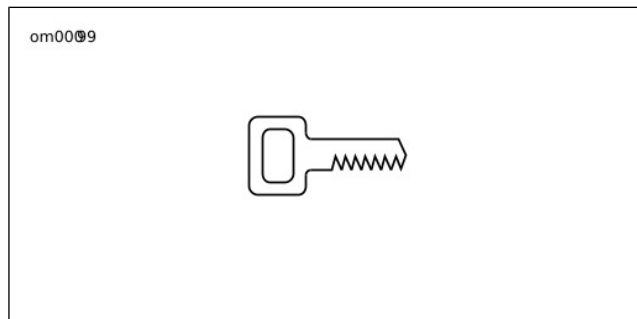

Figure 31. Security System Icon

TRANSPORT MODE

It is possible to arm the security system without enabling the motion detector for one ignition cycle. This allows the vehicle to be moved in an immobilized state for transport.

The transport mode is used for moving the vehicle or transporting on a trailer with the security system armed and without tripping the alarm. When the vehicle is in the transport mode, the security system does not respond to motion detection.

1. To exit the transport mode, use the key fob to disarm the vehicle.
2. To enter the transport mode, refer to Table 20.

NOTE

Transport mode is especially useful when working on

international vehicles. If it is not used, the alarm will activate under many typical service activities.

Table 20. Transport Mode

STEP NO.	ACTION	WAIT FOR CONFIRMATION	NOTES
1	Turn IGN key ON		
2	Press and hold key fob button until confirmation is received	3 flashes turn signals & indicators	
3	Turn IGN key OFF		
4	Press and hold key fob button until confirmation is received	3 flashes turn signals & indicators	The vehicle can be moved without tripping the alarm

SECURITY SYSTEM CUSTOM SETUP

Key Fob Assignment

The key fob on security system motorcycles must be set so it will operate the alarm system on the vehicle. This assignment must be completed with no pauses greater than 10 seconds between steps. Turn the ignition OFF after both key fobs have been assigned. The programming mode will also exit after 60 seconds has elapsed without detecting any key fob sign up messages or turn signal activity.

Procedure

To assign a key fob to a motorcycle, refer to Table 21.

Two key fobs may be assigned to the security system. The first successful attempt to program a key fob will disable all previously assigned key fobs. If a second key fob is to be programmed, it must be done in the same programming sequence as the initial key fob.

Table 21. Key Fob Assignment

STEP NO.	ACTION	WAIT FOR CONFIRMATION	NOTES
1	Turn IGN key ON-OFF-ON-OFF-ON		
2	Press left turn switch 2 times and release	2-3 flashes turn signals & indicators depending on vehicle configuration (See BATTERY DISCONNECTS AND CONFIGURING section)	2 flashes - North American/Domestic configuration security system 3 flashes - international configuration security system
3	Press right turn switch 1 time and release	1 flash turn signals & indicators	
4	Press left turn switch 1 time and release	2 flashes turn signals & indicators	
5	Press and hold key fob button until confirmation is received	2 flashes turn signals & indicators	This may take 10-25 seconds
6	If you have two key fobs, press and hold button on second key fob until confirmation is received	2 flashes turn signals & indicators	Optional step
7	Turn IGN key OFF		

PERSONAL CODE

Creating Code for the First Time

The personal code consists of five digits entered using the left and right turn signal switches. Each digit can be any number from 1-9. The personal code is intended to be used to disarm the vehicle in case the key fob is not functioning.

Record your personal code on the card(s) provided in the rear of the Owner's Manual. Carry one for reference in your wallet when riding.

To set a personal code on a motorcycle with no code previously installed, refer to Table 22. The procedure listed uses 3-1-3-1-3 as the sample personal code.

NOTE

For better security, do not use 3-1-3-1-3 as a personal code. It is shown as an example only.

Decide what five digit code the owner would like to use. The code will be programmed using the turn signal switches and key fob. Record your personal code on the card(s) provided in the rear of the Owner's Manual. Carry one for reference in your wallet when riding.

- When programming the personal code, the security lamp flashes to provide feedback when entering each digit.
- The number of security lamp flashes corresponds to the number currently selected for a given digit. Therefore, the lamp may flash 1-9 times depending on the number entered.
- Press the left turn switch one time to increment each digit of the code.

- Quickly press the key fob button twice to advance to the next digit of the code.

NOTE

The programming mode exits upon turning the key switch to OFF or if no turn signal switch/key fob button activity occurs for 60 seconds. No data is saved for partial configuration attempts of a first time entry.

Modifying Existing Codes

If a code was previously entered, the lamp will flash the equivalent digit. Each additional press of the left turn switch will increment the digit.

- To advance from 5 to 6, press and release the left turn switch 1 time.
- To advance from 8 to 2, press and release the left turn switch 3 times (9-1-2).

Table 22. Programming a Personal Code

STEP NO.	ACTION	WAIT FOR CONFIRMATION	NOTES
<i>NOTE: For better security, do not use 3-1-3-1-3 as a personal code. It is shown as an example only.</i>			
1	Set RUN/OFF switch to OFF		Verify that security lamp is not blinking (vehicle is disarmed)
2	Turn IGN key ON-OFF-ON-OFF-ON		

Table 22. Programming a Personal Code

STEP NO.	ACTION	WAIT FOR CONFIRMATION	NOTES
3	Press left turn switch 2 times and release	1-3 flashes turn signals & indicators depending on vehicle configuration (See BATTERY DISCONNECTS AND CONFIGURING section)	1 flash - Worldwide TSSM, no security 2 flashes - North American/Domestic configuration security system 3 flashes - international configuration security system
4	Quickly press key fob button 2 times and release	1 flash turn signals & indicators	Vehicle is in personal code entry mode
5	Press left turn switch 1 time and release	None if no code entered 1-9 flashes if code previously entered	A lack of confirmation flashes indicates no digit is entered
6	In this example, you will press and release three times If code previously entered, count flashes for number and then press and release left turn switch to advance through the digits	Security lamp flashes to indicate each digit selected Digit will display on odometer In this example, the lamp will flash 3 times	You've selected 3 as a number for the first digit
7	Quickly press key fob button 2 times and release	2 flashes turn signals & indicators	You've confirmed 3 as a number for the first digit and have advanced to entering the second digit
8	Press left turn switch 1 time and release	None if no code entered 1-9 flashes if code previously entered	A lack of confirmation flashes indicates no digit is entered

Table 22. Programming a Personal Code

STEP NO.	ACTION	WAIT FOR CONFIRMATION	NOTES
9	In this example, you will perform this step one time If code previously entered, count flashes for number and then press and release left turn switch to advance through the digits	Security lamp flashes to indicate each digit selected Digit will display on odometer In this example, the lamp will flash 1 time	You've selected 1 as a number for the second digit
10	Quickly press key fob button 2 times and release	3 flashes turn signals & indicators	You've confirmed 1 as a number for the second digit and have advanced to entering the third digit
11	Press left turn switch 1 time and release	None if no code entered 1-9 flashes if code previously entered	A lack of confirmation flashes indicates no digit is entered
12	In this example, you will repeat this step three times If code previously entered, count flashes for number and then press and release left turn switch to advance through the digits	Security lamp flashes to indicate each digit selected Digit will display on odometer In this example, the lamp will flash 3 times	You've selected 3 as a number for the third digit
13	Quickly press key fob button 2 times and release	4 flashes turn signals & indicators	You've confirmed 3 as a number for the third digit and have advanced to entering the fourth digit
14	Press left turn switch 1 time and release	None if no code entered 1-9 flashes if code previously entered	A lack of confirmation flashes indicates no digit is entered

Table 22. Programming a Personal Code

STEP NO.	ACTION	WAIT FOR CONFIRMATION	NOTES
15	In this example, you will perform this step one time If code previously entered, count flashes for number and then press and release left turn switch to advance through the digits	Security lamp flashes to indicate each digit selected Digit will display on odometer In this example, the lamp will flash 1 time	You've selected 1 as a number for the fourth digit
16	Quickly press key fob button 2 times and release	5 flashes turn signals & indicators	You've confirmed 1 as a number for the fourth digit and have advanced to entering the fifth digit
17	Press left turn switch 1 time and release	None if no code entered 1-9 flashes if code previously entered	A lack of confirmation flashes indicates no digit is entered
18	In this example, you will repeat this step three times If code previously entered, count flashes for number and then press and release left turn switch to advance through the digits	Security lamp flashes to indicate each digit selected Digit will display on odometer In this example, the lamp will flash 3 times	You've selected 3 as a number for the fifth digit
19	Quickly press key fob button 2 times and release	1 flashes turn signals & indicators	You've confirmed 3 as a number for the fifth digit and have gone back to the first digit
20	Turn IGN key OFF		
21	Write down code in owner's manual		
22	Arm the security system and attempt to disarm using personal code entry		

ENABLE AUTO-ARMING SELECTION

The security system allows remote arming via the key fob at anytime. However, if the system is remotely disarmed (with the key fob) but the ignition key is not turned ON within 30 seconds, the system will rearm itself when auto-arming is enabled.

To set the auto-arming selection, refer to Table 23.

NOTE

Auto-arming configuration cannot be altered on international vehicles.

Table 23. Auto-arming Configuration (Not Available on International Vehicles)

STEP NO.	ACTION	WAIT FOR CONFIRMATION	NOTES
1	Turn IGN key ON-OFF-ON-OFF-ON		
2	Press left turn switch 2 times and release	2 or 3 flashes turn signals & indicators depending on vehicle configuration (See BATTERY DISCONNECTS AND CONFIGURING section)	2 flashes - North American/Domestic configuration security system 3 flashes - international configuration security system
3	Press and hold key fob button until confirmation is received	1 flash turn signals & indicators	
4	Press and hold key fob button until confirmation is received	2 flashes turn signals & indicators	
5	Press left turn switch 1 time and release	Turn signals & indicators flash to indicate the current option selected	1 flash - auto-arming disabled 2 flashes - auto-arming enabled
6	Press and release left turn switch to advance through options	Turn signals & indicators flash to indicate the new option selected	1 flash - auto-arming disabled 2 flashes - auto-arming enabled
7	Turn IGN key OFF		

ALARM SENSITIVITY

The tamper warning has four sensitivity settings:

- Extremely low.
- Low.
- Medium.

- High.

The selection chosen controls the sensitivity of the security system in regard to short disturbances of the vehicle (i.e. someone bumps into the vehicle).

To set alarm sensitivity, refer to Table 24.

Table 24. Alarm Sensitivity Adjustment

STEP NO.	ACTION	WAIT FOR CONFIRMATION	NOTES
1	Turn IGN key ON-OFF-ON-OFF-ON		
2	Press left turn switch 2 times and release	2 or 3 flashes turn signals & indicators depending on vehicle configuration (See BATTERY DISCONNECTS AND CONFIGURING section)	2 flashes - North American/Domestic configuration security system 3 flashes - international configuration security system
3	Press and hold key fob button until confirmation is received	1 flash turn signals & indicators	
4	Press left turn switch 1 time and release	Turn signals & indicators flash to indicate the current option selected	1 flash - extremely low 2 flashes - low sensitivity 3 flashes - medium sensitivity 4 flashes - high sensitivity
5	Press and release left turn switch to advance through options	Turn signals & indicators flash to indicate the new option selected	1 flash - extremely low 2 flashes - low sensitivity 3 flashes - medium sensitivity 4 flashes - high sensitivity
6	Turn IGN key OFF		

STORAGE MODE CONFIGURATION

The security system has a special mode for long term storage. This mode prevents the security system from discharging the battery after a period of days without any ignition key switch activity. Refer to Table 25.

- If the security system is set to infinite, the system will not go into storage mode. In this case, the customer must use a trickle charger to keep the battery from discharging after 60 days of storage.
- Vehicles will enter storage mode whether the security system is armed or disarmed.

In storage mode, all alarm functions are suspended and the receiver is shut down and will not respond to the key fob. The vehicle is immobilized because the starter motor and

Ignition/EFI controllers are disabled. When the storage mode is entered, the security lamp stops flashing to conserve power.

To wake up the security system from storage mode, the ignition key must be turned ON. This will trigger the alarm if the system was previously armed. You must use the key fob or personal code to disarm the system and stop the alarm.

If the ignition is switched from ON-OFF quickly, then the security system will wake-up without activating the alarm.

To set the storage mode preferences, refer to Table 26.

Table 25. Storage Mode Options

FLASHES	TIME
1 flash	10 days (factory setting)
2 flashes	20 days
3 flashes	60 days
4 flashes	infinite

Table 26. Storage Mode Configuration

STEP NO.	ACTION	WAIT FOR CONFIRMATION	NOTES
1	Turn IGN key ON-OFF-ON-OFF-ON		
2	Press left turn switch 2 times and release	2 or 3 flashes turn signals & indicators depending on vehicle configuration (See BATTERY DISCONNECTS AND CONFIGURING section)	2 flashes - North American/Domestic configuration security system 3 flashes - international configuration security system

Table 26. Storage Mode Configuration

STEP NO.	ACTION	WAIT FOR CONFIRMATION	NOTES
3	Press and hold key fob button until confirmation is received	1 flash turn signals & indicators	
4	Release and then hold key fob button until confirmation is received	2 flashes turn signals & indicators	
5	Release and then hold key fob button until confirmation is received	3 flashes turn signals & indicators	
6	Press left turn switch 1 time and release	Turn signals & indicators flash to indicate the current option selected	see Storage Mode Options table
7	Press left turn switch to advance through options	Turn signals & indicators flash to indicate the new option selected	see Storage Mode Options table
8	Turn IGN key OFF		

SECURITY SYSTEM MAINTENANCE

Key Fob Battery Replacement

Replace the key fob battery every 2 years.

1. See Figure 32. Place a thin blade between the 2 halves of the key fob case and slowly turn to open.
2. See Figure 33. Remove the old battery and discard.

NOTE

Dispose of old battery in accordance with local regulations.

3. Install a new battery (Panasonic® 2032 or equivalent) with the positive (+) side down.
4. Verify the button rubber is fully seated.
5. Close the case by aligning the two halves and snap together.
6. While standing next to the motorcycle, press and hold the key fob button for 10-15 seconds until the security system responds with two turn signal flashes/siren chirps.

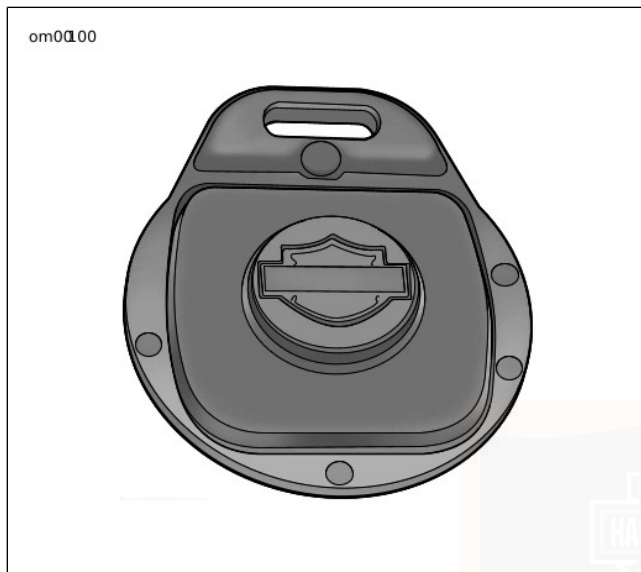
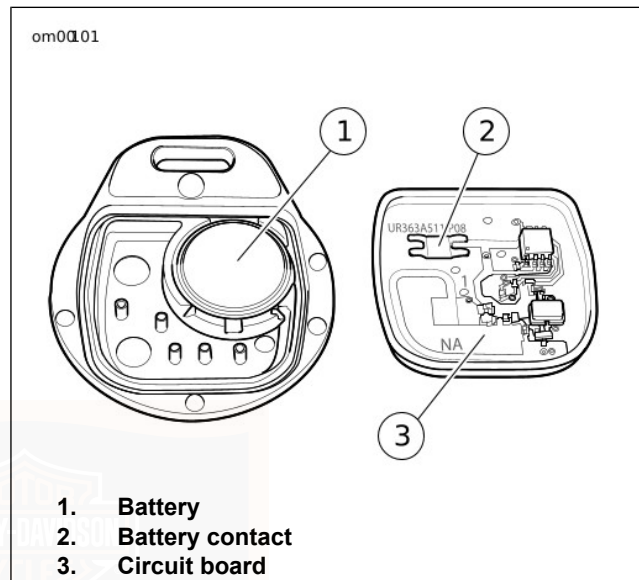

Figure 32. Key Fob Open Case: Front



1. **Battery**
2. **Battery contact**
3. **Circuit board**

Figure 33. Key Fob Battery Replacement

DISABLING THE SYSTEM

Disarm the security system using the key fob or personal code. At this point, the security fuse may be removed or battery disconnected.

BATTERY DISCONNECTS AND CONFIGURING

After reconnecting a battery, the security system will not enter the configuration mode on the first attempt. Therefore, after all battery reconnects, the configuration sequence must be modified as follows.

1. Set run switch to **OFF**, cycle ignition key **ON-OFF-ON-OFF-ON** and press left turn signal switch twice.
2. Wait for one to three confirmation flashes of the turn signals and then set ignition key switch to **OFF**.
3. Repeat steps listed above.
4. Continue with configuration sequence listed.

TROUBLESHOOTING THE SECURITY SYSTEM

If the key fob button has been pressed numerous times while away from the vehicle, the key fob may fall out of synchronization with the security system. If this happens, the security system might fail to recognize the key fobs commands.

To solve this problem, press and hold the key fob button for 10-15 seconds until the security system responds with two turn signal flashes. After confirmation, you may resume normal key fob operation.

Siren Diagnostics

- See Figure 34. If the siren is armed and the internal siren battery is dead, shorted, disconnected, or has been charging for a period longer than 24 hours, the siren will respond with three chirps on arming instead of two.
- The internal siren battery may not charge if the vehicle's battery is less than 12.5 volts.
- If the siren does not chirp two or three times on a valid arming command from the security system, the siren is either not connected, not working, or the siren wiring was opened or shorted while the siren was disarmed.
- If the siren enters the self-driven mode where it is powered from the siren internal 9 volt battery, the turn signal lamps may or may not alternately flash. If the security system activates the siren, the turn signal lamps will alternately flash. If the siren has been armed and a security event occurs, and the siren is in self-driven mode, the siren will alarm for 20 to 30 seconds and then turn off for 5 to 10 seconds. This alarm cycle will be repeated ten times if the siren is in the self-driven mode.

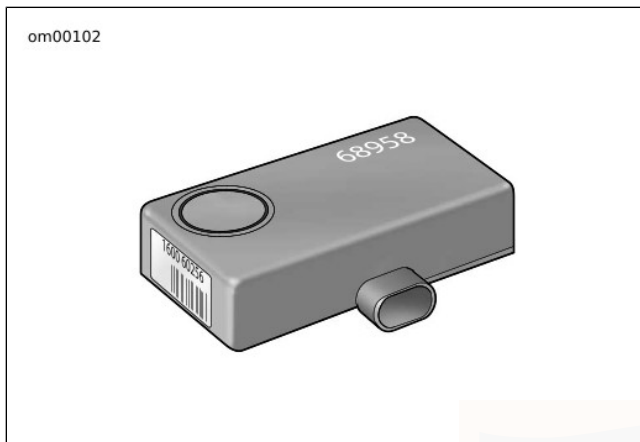

Figure 34. Siren



OPERATING RECOMMENDATIONS: SPORTSTER MODELS

NOTICE

Do not run the engine at extremely high RPM with clutch disengaged or transmission in neutral. Running an engine at high RPM can result in engine damage. (00177a)

NOTICE

Do not exceed the maximum safe RPM specified below under any conditions. Exceeding the maximum safe engine RPM can result in equipment damage. (00248a)

- The maximum recommended safe engine speed is 6000 RPM.
- Do not idle engine unnecessarily for more than a few minutes with motorcycle standing still.

If motorcycle will not be ridden for a period of three weeks or more with security system armed, it is recommended to connect a Battery Tender to maintain battery charge. If security system will not be armed, it is recommended that the 30 amp maxi-fuse be removed. See MAINTENANCE AND LUBRICATION > ELECTRICAL PROTECTION: SPORTSTER MODELS (Page 132).

NOTICE

Air-cooled engines require air movement over the cylinders and heads to maintain proper operating temperature. Extended periods of idling or parade duty can overheat the engine, resulting in serious engine damage. (00178a)

An engine running long distances at high speed must be given closer than ordinary attention to avoid overheating and possible engine damage.

NOTE

Have the engine checked regularly and keep it well tuned.

This applies particularly to a motorcycle equipped with windshield and fairing.

⚠ WARNING

When riding on wet roads, brake efficiency and traction are greatly reduced. Failure to use care when braking, accelerating or turning on wet roads can cause loss of control, which could result in death or serious injury. (00041a)

NOTE

When descending upon a long, steep grade, downshift and use engine compression together with intermittent application of both brakes to slow the motorcycle.

⚠ WARNING

Continuous use of brake causes overheating and reduced efficiency, which could result in death or serious injury. (00042a)

NOTICE

Do not coast for long distances with the engine off or idling. The transmission is properly lubricated only when the engine is running. Coasting long distances can result in transmission damage. (00180b)

⚠ WARNING

Do not tow a disabled motorcycle. Towing can adversely affect stability and handling, which could result in death or serious injury. (00017a)

BREAK-IN RIDING RULES

The First 500 Miles (800 Kilometers)

The sound design, quality materials and workmanship that are built into your new Harley-Davidson will give you optimum performance right from the start.

To allow your engine to seat in its critical parts we recommend for the first 500 miles (800 kilometers) you observe the riding rules provided below. Adherence to these recommendations will help to assure good future durability and performance.

1. While riding the first 50 miles (80 kilometers) avoid operating at any steady engine speed for long distances. Keep the engine speed below 3000 RPM in any gear. Do not lug the engine in higher gears by running or accelerating at very low RPM. Do not exceed speed for each gear as noted in Table 27.
2. Up to 500 miles (800 kilometers), avoid operating at any steady engine speed for long distances. Engine speed up to 3500 RPM in any gear is permissible. Do not exceed speed for each gear as noted in Table 28.
3. Avoid fast starts at wide open throttle. Drive slowly until the engine has warmed up.
4. Avoid hard braking. New brakes need to be broken-in by moderate use for the first 200 miles (300 kilometers).

Table 27. Sportster Break-in Speeds: 0-80 kilometers (0-50 miles)

SPEED	GEAR				
	1st	2nd	3rd	4th	5th
km/h	37	53	69	84	97
mi/h	23	33	43	52	60

Table 28. Sportster Break-in Speeds: 80-800 kilometers (50-500 miles)

SPEED	GEAR				
	1st	2nd	3rd	4th	5th
km/h	43	61	80	97	113
mph	27	38	50	60	70

PRE-RIDING CHECKLIST

⚠ WARNING

Identify and understand the specific features of your vehicle. Failure to understand how these features affect the vehicle's operation can lead to an accident, which could result in death or serious injury. (00043b)

Before riding your motorcycle at any time, make a general inspection to be sure it is in safe riding condition.

⚠ WARNING

Stop the engine when refueling or servicing the fuel system. Do not smoke or allow open flame or sparks near gasoline. Gasoline is extremely flammable and highly explosive, which could result in death or serious injury. (00002a)

⚠ WARNING

Avoid spills. Slowly open fuel filler cap. Do not fill above bottom of filler neck insert, leaving air space for fuel expansion. Secure filler cap after refueling. Gasoline is extremely flammable and highly explosive, which could result in death or serious injury. (00028b)

⚠ WARNING

Use care when refueling. Pressurized air in fuel tank can force gasoline to escape through filler tube. Gasoline is extremely flammable and highly explosive, which could result in death or serious injury. (00029a)

1. Verify fuel is present in tank and add fuel if required.
2. Adjust mirrors to proper riding positions.
3. Verify oil is present in oil tank.

4. Check controls to make sure they operate properly. Operate the front and rear brakes, throttle, clutch and shifter. All controls should operate freely without binding.
5. Check steering for proper operation by turning the handlebars through the full operating range. Handlebars should turn smoothly without binding.

⚠ WARNING

Be sure tires are properly inflated, balanced, undamaged, and have adequate tread. Inspect your tires regularly and see a Harley-Davidson dealer for replacements. Riding with excessively worn, unbalanced, improperly inflated, overloaded or damaged tires can lead to tire failure and adversely affect stability and handling, which could result in death or serious injury. (00014b)

6. Check tire condition and pressure. Incorrect pressure will result in poor riding characteristics and can affect handling and stability. Refer to tire specifications for correct inflation pressure to use.
7. Check all electrical equipment and switches including the headlamp, stop lamp, turn signals and horn for proper operation.
8. Check for any fuel, oil or hydraulic fluid leaks.

82 Operation

9. Check secondary belt for wear or damage.
10. Service your motorcycle as necessary.

STARTING THE ENGINE: CARBURETED MODELS

⚠ WARNING

Shift transmission to neutral before starting engine to prevent accidental movement, which could result in death or serious injury. (00044a)

NOTICE

The engine should be allowed to run slowly for 30-60 seconds. This will allow the engine to warm up and let oil reach all surfaces needing lubrication. Failure to comply can result in engine damage. (00181b)

NOTE

Engine off/run switch on the right handlebar control group must be in RUN (ignition ON) position to start engine.

Refer to Table 31. Use the recommended oil for extended or expected temperatures.

If you read this section and still have questions about the correct operation of your motorcycle, talk to an authorized Harley-Davidson dealer.

C.V. Carburetors

NOTE

- *C.V. carburetors have an enricher circuit that will cause the engine to idle at approximately 2000 RPM with the engine at normal operating temperature and the enricher knob pulled fully-out.*
- *The increase in idle speed is intended to alert the rider that the engine is warmed up to normal operating temperature and the enricher knob should be pushed all the way in.*
- *Continuing to use the enricher when the engine is at full operating temperature WILL CAUSE FOULED SPARK PLUGS.*

NOTICE

Pay close attention to the vehicle's warm-up time. Either excessive or insufficient use of the enricher may cause poor performance, erratic idle, poor fuel economy, spark plug fouling and equipment damage. (00164a)

NOTE

The following starting and operating instructions for all Harley-Davidson motorcycles are recommendations. They may be modified for individual vehicles.

Cool Engine

Outside Temperature Cooler Than 60° F (16° C)

1. Turn the fuel valve to the ON position.
2. BE SURE THROTTLE IS CLOSED.
3. Pull enricher knob to full-out position.
4. Turn the ignition/headlamp key switch ON and press starter switch to operate the electric starter.
5. Raise jiffy stand.
6. After initial 15-30 second warm-up, ride for 3 minutes or 2 miles (3.2 kilometers) with enricher knob in full-out position.
7. After 3 minutes or 2 miles (3.2 kilometers), push the enricher knob in to the 1/2 way position. Ride 2 minutes or 2 miles (3.2 kilometers).
8. After 2 minutes or 2 miles (3.2 kilometers), push the enricher knob fully-in.

NOTE

If outside temperature is cooler than 20° F (7° C) it may be necessary to roll the throttle 2 or 3 times.

Outside Temperature Warmer Than 60° F (16° C)

1. Turn the fuel valve to the ON position.

2. BE SURE THROTTLE IS CLOSED.
3. Pull enrichener knob to full-out position.
4. Turn the ignition/headlamp key switch on and press starter switch to operate the electric starter.
5. Raise jiffy stand.
6. After initial 15-30 second warm-up, ride for 1 minute or 1/2 mile (0.8 kilometer) with enrichener knob in full-out position.
7. After 1 minute or 1/2 mile (0.8 kilometer), push the enrichener knob in to the 1/2 way position. Ride 1 minute or a 1/2 mile (0.8 kilometer).
8. After 1 minute or 1/2 mile (0.8 kilometer), push the enrichener knob fully-in.

Warm or Hot Engine

1. Turn the fuel valve to the ON position.
2. Open throttle 1/8-1/4 turn.
3. Turn on ignition/headlamp key switch and operate electric starter. DO NOT USE ENRICHENER.
4. Raise jiffy stand.

NOTE

If the engine does not start after a few turns or if one cylinder fires weakly but engine does not start, it is usually because

of an over-rich (flooded) condition. This is especially true of a hot engine. If the engine is flooded, push enrichener knob in all the way, turn ignition on and operate starter with throttle wide open. DO NOT pump the throttle while turning the engine over.

STOPPING THE ENGINE

1. Stop the engine by turning OFF the engine stop switch on right handlebar.
2. Turn OFF the ignition/headlamp key switch. If the engine should be stalled or stopped in any way, turn off the ignition/headlamp key switch at once to prevent battery discharge.
3. Turn the fuel valve to the OFF position if applicable.

SHIFTING GEARS

Getting Started

NOTICE

The clutch must be fully disengaged before attempting a gear shift. Failure to fully disengage the clutch can result in equipment damage. (00182a)

Gear shift pattern is first gear down, next four gears up.

NOTE

Always start engine with transmission in neutral. Always start motorcycle forward motion from first gear.

1. With motorcycle engine running and jiffy stand retracted, pull the clutch hand lever in against handlebar grip to fully disengage clutch.
2. Push the foot shift lever down to end of its travel and release. The transmission is now in first gear.
3. To start forward motion, release the clutch lever slowly to engage the clutch and at the same time, open throttle gradually.

Upshift (Acceleration)

Refer to Table 29. Engage second gear after the motorcycle has reached at the appropriate shifting speed.

Table 29. Upshift (Acceleration) Gear Speeds

GEAR CHANGE	MPH	KPH
First to second	15	25
Second to third	25	40
Third to fourth	35	55
Fourth to fifth	45	70

1. Close the throttle.
2. Disengage the clutch (pull clutch lever in).

3. See Figure 35. Lift the gear shift lever up to the end of its travel and release.
4. Engage the clutch (release clutch lever) and gradually open the throttle.
5. Repeat the previous steps to engage third, fourth, and fifth gears.

NOTE

- *Disengage the clutch completely before each gear change.*
- *Partially close the throttle so the engine will not drag when clutch is again engaged (clutch lever released).*

Downshift (Deceleration)

▲ WARNING

Do not downshift at speeds higher than those listed. Shifting to lower gears when speed is too high can cause the rear wheel to lose traction and lead to loss of vehicle control, which could result in death or serious injury. (00045b)

Gear shift pattern is first gear down; next four gears up. Refer to Table 30 for shifting speeds.

Table 30. Downshift (Deceleration) Gear Speeds

GEAR CHANGE	MPH	KPH
Fifth to fourth	40	65
Fourth to third	30	50
Third to second	20	30
Second to first	10	15

NOTE

The shifting points shown in the tables constitute a recommendation. Vehicle owners may determine that their own individual shifting patterns may differ than those stated and are additionally appropriate for individual riding styles.

See Figure 36. When engine speed decreases, as in climbing a hill or running at a reduced speed, shift to the next lower gear while partially closing the throttle so the engine accelerates as soon as the clutch lever is released.

NOTE

- Disengage the clutch completely before each gear change.
- Partially close the throttle so the engine will not drag when clutch is again engaged (clutch lever released).

NOTICE

Shift to neutral before stopping engine. Shifting mechanism can be damaged by shifting gears while engine is stopped. (00183a)

The gear shifter mechanism permits shifting the transmission to neutral from either first or second gear.

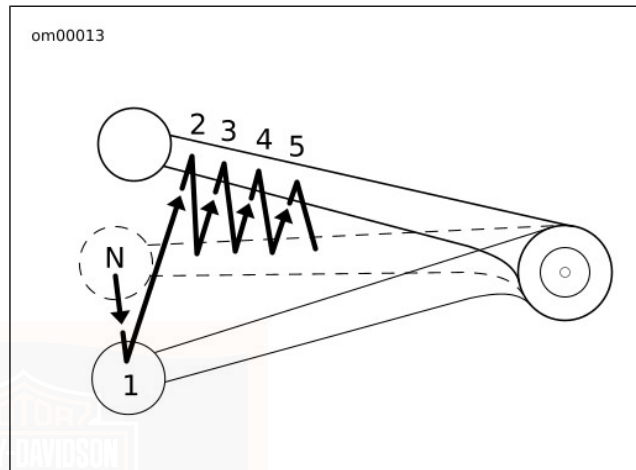

Figure 35. Shifting Sequence: Upshift

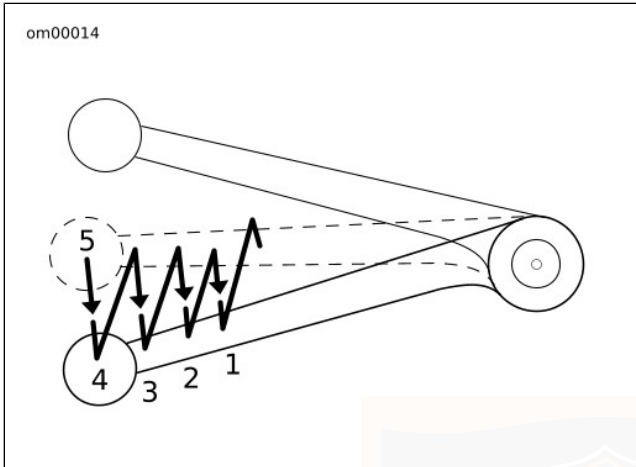
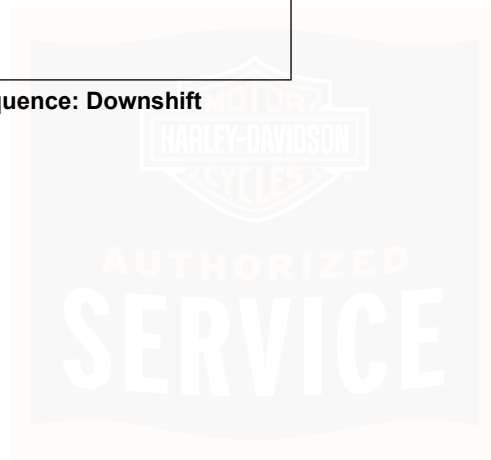

Figure 36. Shifting Sequence: Downshift



NOTES



SAFE OPERATING MAINTENANCE

⚠ WARNING

Perform the service and maintenance operations as indicated in the regular service interval table. Lack of regular maintenance at the recommended intervals can affect the safe operation of your motorcycle, which could result in death or serious injury. (00010a)

Good maintenance creates a safe motorcycle. A careful check of certain equipment must be made after periods of storage. Also, frequently inspect the motorcycle between the regular service intervals to determine if additional maintenance is necessary.

Check the following items:

1. Tires for correct pressure, abrasions or cuts.
2. Belt and primary chain for proper tension, wear or damage.
3. Brakes, steering and throttle for responsiveness and freedom from binding.
4. Brake fluid level and condition. Hydraulic lines and fittings for leaks. Also, check brake pads and discs for wear.
5. Cables for fraying or crimping and free operation.
6. Engine oil and primary chaincase/transmission fluid levels.

7. Headlamp, tail lamp, brake lamp and turn signals for proper operation.

NOTE

Refer to the side view photographs in the front of this manual to locate the items discussed in this section.

BREAK-IN MAINTENANCE

NOTE

The performance of new motorcycle initial service is required to keep your new motorcycle warranty in force and to assure proper emissions system operation.

Refer to Table 37. After a new motorcycle has been ridden its first 1000 miles (1600 kilometers), it should be taken to the dealer from whom it was purchased for initial service operations.

ENGINE LUBRICATION

NOTICE

Do not switch lubricant brands indiscriminately because some lubricants interact chemically when mixed. Use of inferior lubricants can damage the engine. (00184a)

Engine oil is a major factor in the performance and service life of the engine. Always use the proper grade of oil for the

lowest temperature expected before the next scheduled oil change. Refer to Table 31. Your authorized dealer has the proper oil to suit your requirements.

If it is necessary to add oil and Harley-Davidson oil is not available, use an oil certified for diesel engines. Acceptable

diesel engine oil designations include: CF-4, CG-4, CH-4 and CI-4.

The preferred viscosities for the diesel engine oils in descending order are: 20W50, 15W40 and 10W40.

At the first opportunity, see an authorized dealer to change back to 100 percent Harley-Davidson oil.

Table 31. Recommended Engine Oils

H-D TYPE	VISCOSITY	H-D RATING	LOWEST AMBIENT TEMPERATURE	COLD WEATHER STARTS BELOW 50 F (10 C)
H-D Multi-grade	SAE 10W40	HD 360	Below 40 F (4 C)	Excellent
H-D Multi-grade	SAE 20W50	HD 360	Above 40 F (4 C)	Good
H-D Regular Heavy	SAE 50	HD 360	Above 60 F (16 C)	Poor
H-D Extra Heavy	SAE 60	HD 360	Above 80 F (27 C)	Poor

CHECKING OIL LEVEL: SPORTSTER MODELS

NOTICE

Oil level cannot be accurately measured on a cold engine. For pre-ride inspection, with motorcycle leaning on jiffy stand on level ground, oil should register on dipstick between arrows when engine is cold. Do not add oil to bring the level to the FULL mark on a COLD engine. (00185a)

For dipstick location, see Figure 37.

Removing and Replacing Oil Filler Cap

Position motorcycle so that it is leaning on jiffy stand on level ground.

1. Remove filler cap from oil tank on right side of vehicle.
 - a. Press straight down on filler cap and release. Cap will pop up.

- b. Pull up on filler cap while turning counterclockwise one-quarter turn as if unscrewing filler cap.
2. Wipe attached dipstick clean.

NOTE

See Figure 39. Note that dipstick has a wide slot and a narrow slot and can only be inserted in oil tank one way.

3. Insert dipstick into tank. Turn filler cap 1/4 turn as if screwing filler cap into tank. Press down on cap until flush with oil tank.

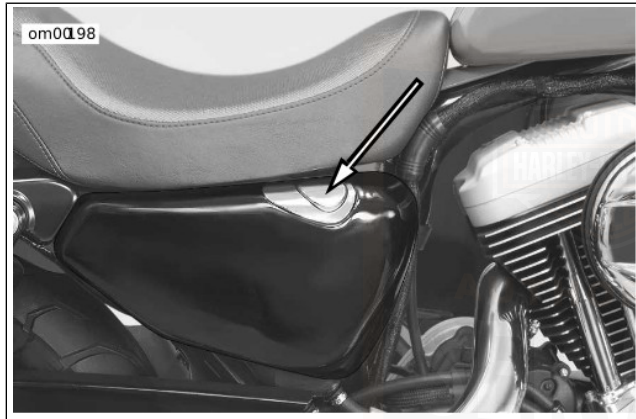

Figure 37. Oil Dipstick Location: Sportster Models

Oil Level Cold Check

1. Position motorcycle so that it is leaning on jiffy stand on level ground.
2. Remove filler cap. Wipe attached dipstick clean. Reinstall oil filler cap in tank.
3. Remove oil filler cap again and check oil level on dipstick. See Figure 38. Dipstick has two marks. If oil level is at or below lower mark, add only enough oil to bring the level to a point between the two arrows on the dipstick. Replace filler cap.

NOTE

Refer to Table 31. Use only recommended oil specified under MAINTENANCE AND LUBRICATION > ENGINE LUBRICATION (Page 89).

Oil Level Hot Check

1. Run engine until engine oil is at normal operating temperature. Turn engine off.
2. Position motorcycle so that it is leaning on jiffy stand on level ground.
3. Remove filler cap. Wipe attached dipstick clean. Reinstall oil filler cap in tank.

- Remove filler cap again and check warm oil level on dipstick. See Figure 38. Dipstick has two marks. If oil level in tank is at or below lower mark, add one quart (0.946 liter) of Harley-Davidson oil to tank. Replace filler cap.

NOTE

Refer to Table 31. Use only recommended oil specified under MAINTENANCE AND LUBRICATION > ENGINE LUBRICATION (Page 89).

- Place filler cap/dipstick back into oil tank.
- If you added oil in step 4, remove filler cap and verify correct engine oil level in oil tank. Do not fill oil tank to the level above upper mark on dipstick. Replace filler cap.

NOTICE

Do not allow hot oil level to fall below Add/Fill mark on dipstick. Doing so can result in equipment damage and/or equipment malfunction. (00189a)

NOTICE

Do not overfill oil. Doing so can result in oil carryover to the air cleaner leading to equipment damage and/or equipment malfunction. (00190b)

- Check engine oil supply at each complete fuel refill.

- Refer to Table 37. Oil should be changed at specified intervals in normal service at warm or moderate temperatures.
- See MAINTENANCE AND LUBRICATION > WINTER LUBRICATION (Page 97). Oil change intervals should be shorter in cold weather. The same holds true if the motorcycle is ridden hard under dusty conditions.

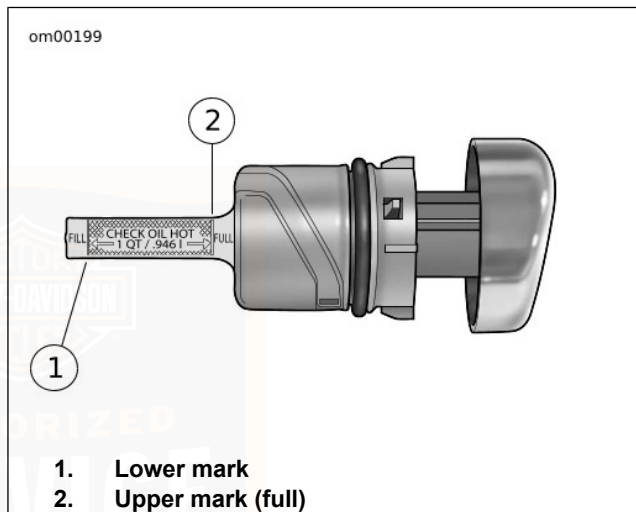

Figure 38. Filler Cap/Dipstick: Sportster Models

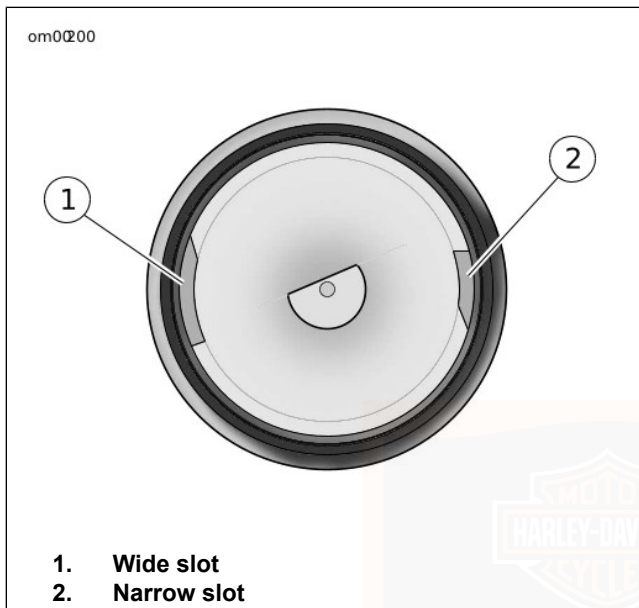

Figure 39. Filler Cap/Dipstick Slots: Sportster Models

CHANGING OIL AND OIL FILTER: SPORTSTER MODELS

NOTICE

Do not switch lubricant brands indiscriminately because some lubricants interact chemically when mixed. Use of inferior lubricants can damage the engine. (00184a)

See Figure 40. Sportster motorcycles use a chrome or black oil filter. Oil filters are located on an oil filter mount in front of the engine.

⚠ WARNING

Be sure that no lubricants or fluids get on tires, wheels or brakes when changing fluid. Traction can be adversely affected, which could result in loss of control of the motorcycle and death or serious injury. (00047d)

Removal and Draining

1. Remove the oil filler plug/dipstick.

NOTE

Oil will flow more quickly if the filler cap/dipstick is removed from the oil tank.

2. Place a suitable container under the engine crankcase. The container must be able to hold approximately 4 U.S. quarts (3.8 liters).
3. See Figure 41. Locate the oil tank drain hose and bracket secured to frame underneath motorcycle.
4. Remove the bracket from frame.
9. Discard oil filter.

NOTE

Dispose of oil and oil filter in accordance with local regulations.

NOTICE

Use Harley-Davidson oil filter wrench for filter removal. This tool can prevent damage to crankshaft position sensor and/or sensor cable. (00192b)

5. Remove worm clamp and insert the free end of the drain hose into the container. Completely drain engine oil from oil tank. It is not necessary to drain engine crankcase.
6. Return oil drain hose to bracket. Tighten worm clamp. Reattach bracket to motorcycle frame.
7. Move drain pan beneath front of engine crankcase.
8. Turn oil filter counterclockwise to remove from filter mount.

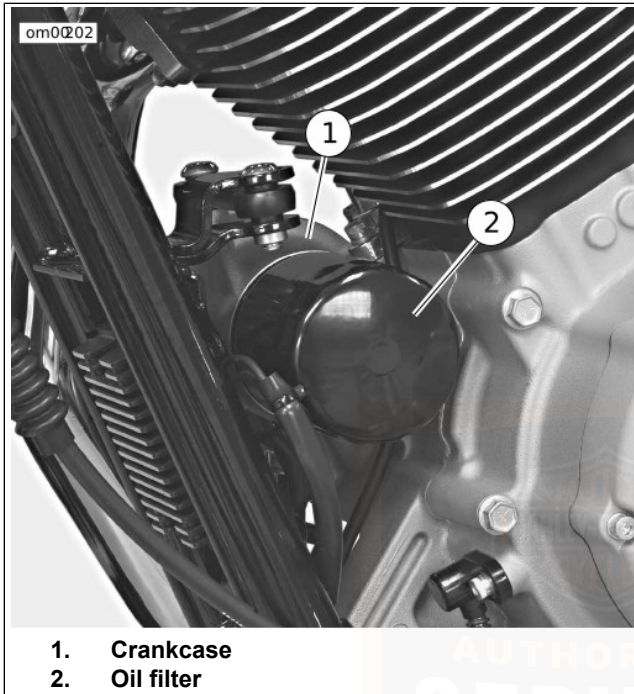

Figure 40. Oil Filter: Sportster Models

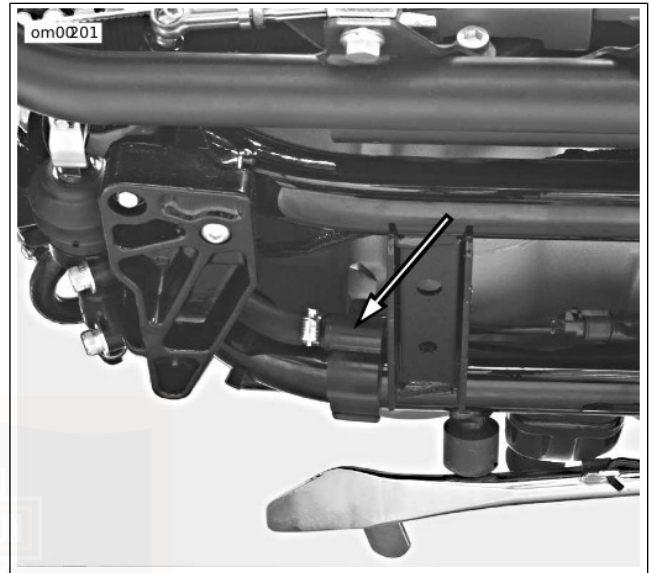

Figure 41. Oil Tank Drain Hose and Bracket: Sportster Models

Installation and Filling

NOTICE

Do not overfill oil. Doing so can result in oil carryover to the air cleaner leading to equipment damage and/or equipment malfunction. (00190b)

1. Pour about 4 fluid ounces (U.S.) (120 milliliters) of fresh, clean engine oil into **new** oil filter. Allow time for oil to soak into filter element.

NOTE

Partially fill oil filter before installation to minimize the time required for buildup of oil pressure when engine is first started.

2. See Figure 42. Wipe filter gasket contact surface of oil filter mount with a clean cloth. Surface should be smooth and free of any debris or old gasket material.
3. Apply a thin film of oil to gasket contact surface on crankcase (3), gasket and **new** oil filter.
4. Screw filter onto adapter until gasket contacts surface. Then apply another 1/2-3/4 turn after gasket contacts filter mounting surface.

NOTICE

Detach frame clip from frame tube. Loosen worm clamp and remove drain hose from frame clip. Allow a small amount of oil to flow from hose before reconnection. This action removes air from the drain hose and reduces the possibility of oil pump cavitation. (00355a)

5. See Figure 41. Use bracket to secure oil tank drain hose to underside of motorcycle frame.
6. Refer to Table 31. Install 3.6 quarts U.S. (3.4 liters) to engine oil tank minus the 4 fluid ounces (120 milliliters) added in step 1. Always use the proper grade of oil for the lowest expected air temperature before the next regularly scheduled oil change.
7. Start engine. Verify that oil pressure signal light turns off when engine speed is 1000 RPM or above.
8. Install filler cap/dipstick onto oil tank. Make sure cap is fully seated.
9. Check for oil leaks at oil filter and oil tank drain hose. Turn engine off.

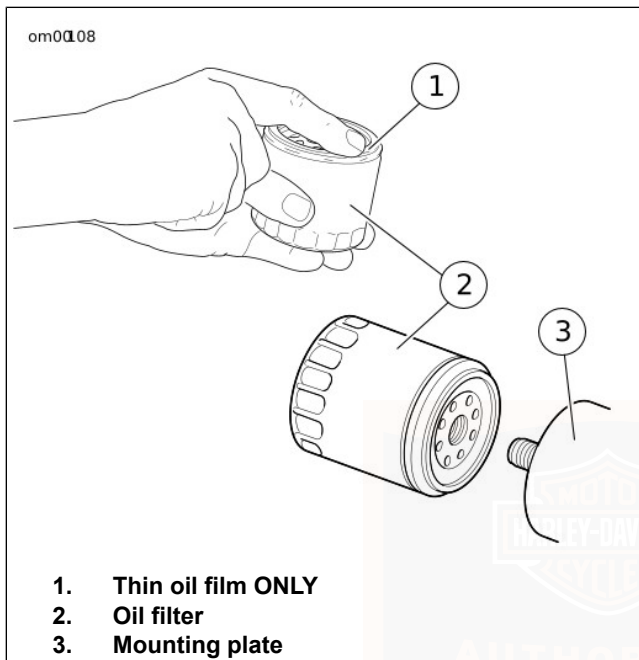

Figure 42. Applying Thin Oil Film

WINTER LUBRICATION

In colder climates, the engine oil change interval should be shorter than normal. Motorcycles used only for short runs must have the engine oil changed more frequently and have

a thorough tank flush-out before **new** oil is put in. See an authorized dealer.

NOTE

The further below freezing the temperature drops, the shorter the oil change interval should be.

Water vapor is a normal by-product of combustion in any engine. During cold weather operation, some of the water vapor condenses to liquid form on the cool metal surfaces inside the engine. In freezing weather this water will become slush or ice and, if allowed to accumulate too long, may block the oil lines and cause damage to the engine.

If the engine is run frequently and allowed to thoroughly warm up, most of this water will become vapor again and will be blown out through the crankcase breather.

If the engine is not run frequently and allowed to thoroughly warm up, this water will accumulate, mix with the engine oil and form a sludge that is harmful to the engine.

TRANSMISSION LUBRICATION: SPORTSTER MODELS

The transmission lubricant level should be checked monthly.

Refer to Table 37. The transmission should be drained and refilled with fresh lubricant at proper intervals. For best results, drain lubricant while hot.

NOTE

When checking the transmission lubricant level, motorcycle should be standing **STRAIGHT UP**, not leaning on the jiffy stand. Keep motorcycle upright for a short period of time to equalize lubricant level in the transmission compartments.

Check Lubricant Level

1. Ride motorcycle until engine is warmed up to normal operating temperature.
2. Position motorcycle straight up.
3. See Figure 43. Remove screws with washers from clutch inspection cover (1). Remove clutch inspection cover from primary cover. Exercise caution to avoid damaging or dislodging quad ring in primary cover.

NOTE

The filler access is the clutch inspection cover.

NOTICE

When draining or adding lubricant, do not allow dirt, debris or other contaminants to enter the engine. (00198a)

▲ WARNING

Be sure that no lubricants or fluids get on tires, wheels or brakes when changing fluid. Traction can be adversely affected, which could result in loss of control of the motorcycle and death or serious injury. (00047d)

NOTICE

Do not overfill the primary chaincase with lubricant. Overfilling can cause rough clutch engagement, incomplete disengagement, clutch drag and/or difficulty in finding neutral at engine idle. (00199b)

4. See Figure 44. Verify that lubricant level (5) is even with bottom of clutch diaphragm spring (1).

NOTE

Add only enough of Harley-Davidson **SPORT-TRANS FLUID** (Part No. 98854-96 quart or Part No. 98855-96 gallon) through clutch inspection cover opening until the lubricant reaches the bottom of clutch diaphragm spring (1).

5. Install clutch inspection cover on primary cover using screws with washers removed in step 3. Tighten screws in a crosswise pattern to 9.5–12.2 N·m (84–108 in-lbs).
6. Start engine. Check for any lubricant leaks.

7. Turn engine off.

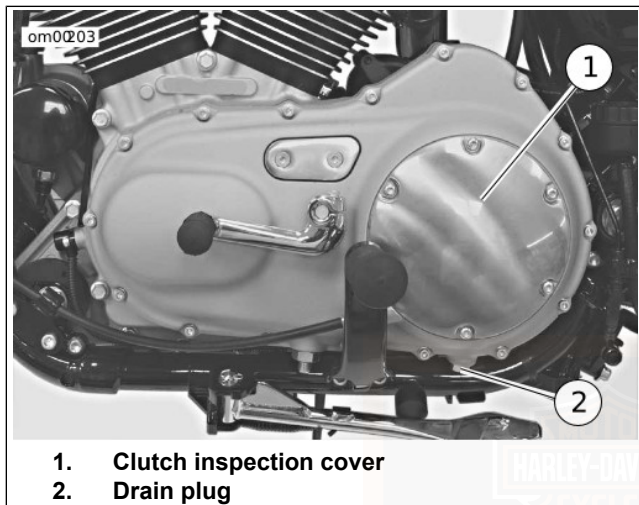

1. Clutch inspection cover
2. Drain plug

Figure 43. Primary Cover: Sportster Models

Changing Lubricant

1. Ride motorcycle until engine is warmed up to normal operating temperature.

2. When the engine reaches normal operating temperature, turn the engine off and position motorcycle on jiffy stand. This will allow the chaincase lubricant to drain out of transmission.
3. See Figure 43. Position a suitable container under transmission drain plug (2).
4. The drain plug is located under the clutch, on the underside of the chaincase. Remove drain plug and drain lubricant.
5. Position the motorcycle STRAIGHT UP and LEVEL. This allows additional fluid to be drained from clutch compartment.

NOTE

Dispose of transmission lubricant in accordance with local regulations.

6. Remove foreign material from magnetic drain plug. Install drain plug and tighten to 19–28.5 N·m (14–21 ft-lbs).

NOTICE

Do not over-tighten filler or drain plug. Doing so could result in a lubricant leak. (00200b)

NOTICE

When draining or adding lubricant, do not allow dirt, debris or other contaminants to enter the engine. (00198a)

⚠ WARNING

Be sure that no lubricants or fluids get on tires, wheels or brakes when changing fluid. Traction can be adversely affected, which could result in loss of control of the motorcycle and death or serious injury. (00047d)

NOTICE

Do not overfill the primary chaincase with lubricant. Overfilling can cause rough clutch engagement, incomplete disengagement, clutch drag and/or difficulty in finding neutral at engine idle. (00199b)

7. See Figure 43. Remove screws with washers from clutch inspection cover (1). Remove clutch inspection cover from primary cover. Exercise caution to avoid damaging or dislodging quad-ring in primary cover.

NOTE

The filler access is the clutch inspection cover.

8. See Figure 44. Add 32 fluid ounces (946 milliliters) of Harley-Davidson SPORT-TRANS FLUID (Part No. 98854-96 quart or Part No. 98855-96 gallon) through clutch inspection cover opening or until the lubricant reaches the bottom of clutch diaphragm spring (1).
9. Install clutch inspection cover on primary cover using screws with washers removed in step 6. Tighten screws in a crosswise pattern to 9.5–12.2 N·m (84–108 in-lbs).
10. Start engine. Check for any lubricant leaks.
11. Turn engine off.

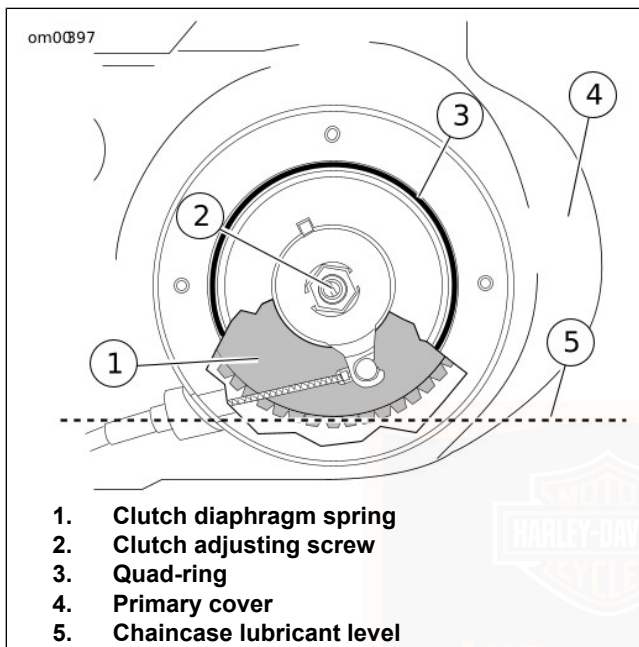

Figure 44. Chaincase Lubricant Level: Sportster Models

PRIMARY CHAIN ADJUSTMENT: SPORTSTER MODELS

General

Refer to Table 37. Primary (front) chain adjustment should be checked at proper intervals and serviced as necessary. If the chain is allowed to run loose, it will cause the motorcycle to jerk when running at low speed, and chain and sprockets will wear excessively. If this happens, see a Harley-Davidson dealer or Service Manual for adjustment procedure.

Table 32. Primary Chain Adjustment: Sportster Models

FREE PLAY	MILLIMETERS	INCHES
COLD engine	9.5-12.7	3/8-1/2
HOT engine	6.3-9.5	1/4-3/8

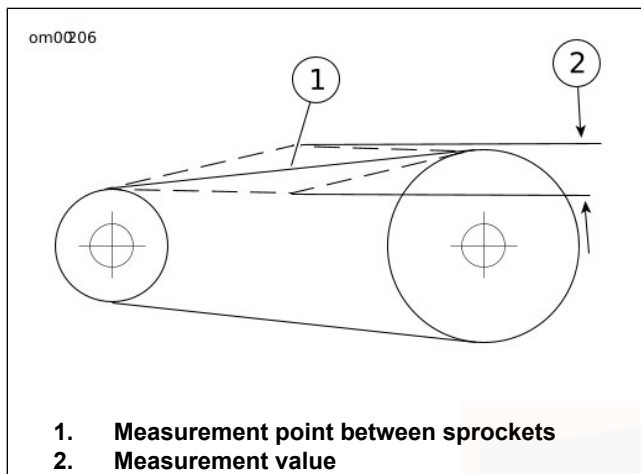

Figure 45. Primary Chain Vertical Free Play: Sportster Models

Procedure

See Figure 46. The primary chain can be adjusted without removing the primary cover (2).

⚠ WARNING

To prevent accidental vehicle start-up, which could cause death or serious injury, disconnect negative (-) battery cable before proceeding. (00048a)

1. Unthread nut and remove battery negative cable (black) from crankcase stud.
2. Remove the two hex socket screws which secure primary chain inspection cover (1).
3. Rotate sprockets to find tightest point on primary chain.

NOTICE

Do not adjust the primary chain tighter than specified. Running chain too tight will result in excessive wear. (00202a)

4. Loosen locknut. Turn chain adjuster screw clockwise (inward) to reduce free play or counterclockwise (outward) to increase free play. Vertical free play must fall within the limits specified.

NOTE

Refer to Table 32. If vertical free play cannot be set within the limits specified, then primary chain and/or chain adjuster are worn beyond adjustment limits. Replace parts as necessary.

5. See Figure 46. When tension is set correctly, tighten locknut (6) to 27–34 N·m (20–25 ft-lbs).

- Install primary chain inspection cover (1). Tighten hex socket screws to 4.5–6.8 N·m (40–60 in-lbs).

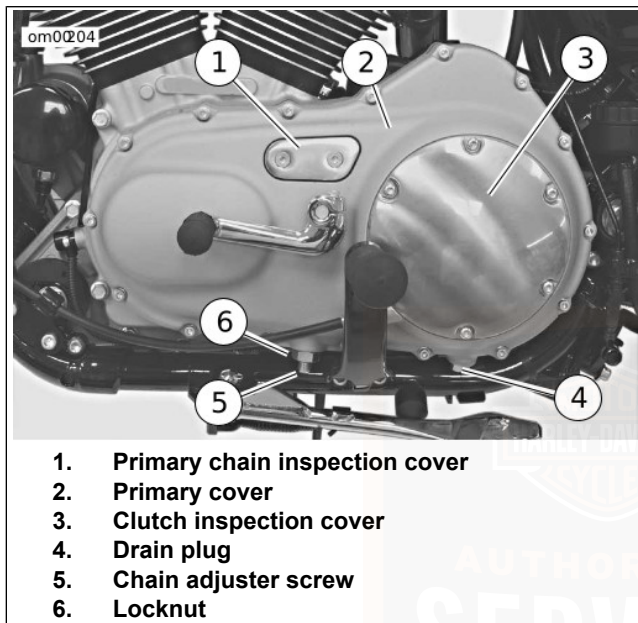

Figure 46. Primary Chain Adjuster: Sportster Models

REAR DRIVE BELT: SPORTSTER MODELS

General

The inner tooth surface of the secondary belt has a thin coating of polyethylene lubricant. During initial operation, this coating will wear off as it is burnished into the belt fabric. This is a normal condition and not an indication of belt wear.

Refer to Table 37. Belt tension is set at the factory and should be checked after the first 1000 miles (1600 kilometers) and at proper intervals thereafter.

Table 33. Belt Deflection: 2005 Sportster Models

MODELS	MILLIMETERS	INCHES
883C, 1200C	6.5-7.9	1/4-5/16
883, 883L, 883R, 1200R	9.5-11.1	3/8-7/16

Checking Deflection

See Figure 47. With the rear wheel on the ground and one rider sitting on the motorcycle, use the BELT TENSION GAUGE (Part No. HD-35381) to apply 10 lbs. (4.5 kg) of force at the midpoint of the bottom belt strand. Belt deflection for 883 and 1200 Custom models should be 1/4-5/16 in. (6.5-7.9 mm). Belt deflection for 883 standard and 1200 Roadster models should be 3/8-7/16 in. (9.5-11.1 mm). If belt tension

adjustment is necessary, see a Harley-Davidson dealer or follow the instructions given in the applicable Service Manual.

⚠ WARNING

Be sure wheel and brake caliper are aligned. Riding with a misaligned wheel or brake caliper can cause the brake disc to bind and lead to loss of control, which could result in death or serious injury. (00050a)

Check rear brake caliper position on rear brake disc. Disc should run true within brake caliper.

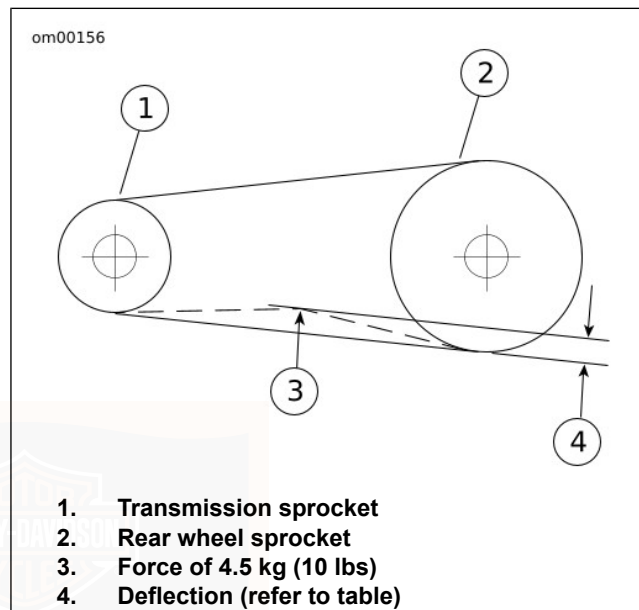

Figure 47. Check Belt Deflection: Sportster Models

CHASSIS LUBRICATION

Refer to Table 37 for all maintenance schedules.

NOTICE

Do not switch lubricant brands indiscriminately because some lubricants interact chemically when mixed. Use of inferior lubricants can damage the engine. (00184a)

1. Use recommended special purpose grease for steering head bearings. Use a multipurpose chassis grease for other applications.
2. Remove and lubricate handlebar throttle control grip sleeve with fresh graphite at proper intervals.
3. Lubricate throttle control cables and clutch control cable at proper intervals.
4. Lubricate front brake hand lever and clutch control hand lever only if necessary.
5. Inspect rear fork pivot shaft bearings.
6. Pack the steering head bearings with fresh grease at proper intervals.
7. Lubricate the jiffy stand mechanism with LOCTITE AEROSOL ANTI-SEIZE at proper intervals.

NOTE

For model specific information regarding the chassis lubrication, refer to the appropriate Service Manual or see a Harley-Davidson dealer.

OIL APPLICATIONS

Refer to Table 37 for all control connections and parts. Vehicle should be oiled at regular intervals, particularly after washing motorcycle or driving in wet weather.

FRONT FORK OIL

Refer to Table 37. Drain front fork oil and refill at proper intervals. If fork does not appear to be working properly or an appreciable amount of oil leakage should develop, see a Harley-Davidson dealer. If there is insufficient oil in either side of fork, the rebound action will be incorrect.

FUEL STRAINER

Carbureted Models Only

See Figure 23. A screen type fuel strainer is located on top of the supply valve inside the fuel tank. Screen should be inspected/cleaned at proper intervals. Check the fuel valve, lines and fittings for leakage as part of the pre-ride inspection. Refer to Table 37.

CLUTCH

NOTICE

The clutch control cable must be oiled and adjusted periodically to compensate for lining wear. Failure to oil and adjust the clutch control cable can result in equipment damage. (00203c)

The need for attention to clutch and controls will be indicated by the clutch slipping under load or dragging when released. In this situation, check the control cable adjustment first. See a Harley-Davidson dealer for proper service.

HYDRAULIC LIFTERS

The hydraulic lifters are self-adjusting. They automatically adjust length to compensate for engine expansion and valve mechanism wear. This keeps the valve mechanism free of lash when the engine is running.

When starting an engine which has been turned off even for a few minutes, the valve mechanism may be slightly noisy until the hydraulic units completely refill with oil. If at any time the valve mechanism becomes abnormally noisy, other than for a short period immediately after engine is started, it is an indication that one or more of the hydraulic units may not be functioning properly.

Always check the oil supply in the oil tank first since normal circulation of oil through the engine is necessary for proper operation of the hydraulic units.

If there is oil in the tank, the units may not be functioning properly because of dirt in the oil supply passages leading to the lifter units. See a Harley-Davidson dealer for service.

FRONT FORK BEARINGS

⚠ WARNING

Adjustments to steering head bearings should be performed by a Harley-Davidson dealer. Improperly adjusted bearings can adversely affect handling and stability, which could result in death or serious injury. (00051b)

Refer to Table 37. Check front fork for proper bearing adjustment and lubricate bearings at proper intervals.

With motorcycle front end raised off the floor, be sure front fork turns freely without any binding or interference and that there is no appreciable front to rear fork shake indicating excessive bearing looseness. Steering head bearings should be adjusted according to Service Manual procedure, if necessary.

REAR FORK PIVOT SHAFT

Refer to Table 37. Check the tightness of the rear fork pivot shaft fastener at proper intervals.

NOTE

For model specific information regarding the rear fork pivot shaft, refer to the appropriate Service Manual or see a Harley-Davidson dealer.

BRAKES: SPORTSTER MODELS

⚠ WARNING

Inspect brake pads for wear at service maintenance intervals. If you ride under adverse conditions (steep hills, heavy traffic, etc.), inspect more frequently. Excessively worn brake pads can lead to brake failure, which could result in death or serious injury. (00052a)

1. Refer to Table 37. Check brake pads and brake discs for wear at proper intervals.
2. Check the fluid level in the master cylinder reservoirs at regular intervals.
3. If level is low, clean dirt and debris from reservoir cover before removing.

⚠ CAUTION

Direct contact of DOT 5 brake fluid with eyes can cause eye irritation, swelling, and redness. Avoid eye contact. In case of eye contact flush with large amounts of water and get medical attention. Swallowing large amounts of DOT 5 brake fluid can cause digestive discomfort. If swallowed, obtain medical attention. Use in well ventilated area. KEEP OUT OF REACH OF CHILDREN. (00144b)

4. Add D.O.T. 5 SILICONE HYDRAULIC BRAKE FLUID (Part No. 99902-77) if necessary.

NOTE

Use only D.O.T. 5 SILICONE HYDRAULIC BRAKE FLUID (Part No. 99902-77) approved for brake system use and available from a Harley-Davidson dealer.

5. Replace brake rubber components on master cylinders and calipers.
6. Lubricate brake caliper pins at regular intervals.

⚠ WARNING

Always replace brake pads in complete sets for correct and safe brake operation. Improper brake operation could result in death or serious injury. (00111a)

Harley-Davidson has provided your new motorcycle with the optimum brake pad friction material available. It is selected to give the best performance possible under dry, wet and high operating temperature conditions. It exceeds all regulatory requirements currently in effect. However, during some braking conditions you may experience noise. This is normal for this friction material.

▲ WARNING

Brakes are a critical safety component. Contact a Harley-Davidson dealer for brake repair or replacement. Improperly serviced brakes can adversely affect brake performance, which could result in death or serious injury. (00054a)

Visual inspection of brake pads can be made without removing the caliper. View the lower area of each caliper with a flashlight.

▲ WARNING

Perform routine scheduled brake maintenance. Lack of maintenance at recommended intervals can adversely affect brake performance, which could result in death or serious injury. (00055a)

NOTE

- *If the brake pad friction material is 0.04 inch (1.00 millimeter) thick or less, the pads must be replaced immediately.*
- *Always replace brake pads in pairs.*

The rear brake outer pad on all models can be measured from the caliper bracket side using a thin plastic 6.0 inch (152.4 millimeter) rule. Place the rule against the brake disc through the space alongside the caliper.

NOTE

The outer surface of the brake pad backing plate should measure 0.04 inch (1.00 millimeter) or more away from the brake disc.

TIRES

See SPECIFICATIONS > SPECIFICATIONS: 2005 SPORTSTER MODELS (Page 31) for tire pressures and sizes.

- Be sure to keep tires properly inflated.
- Follow tire data for correct cold tire inflation pressures.
- Check before riding when tires are cold.
- Do not over-inflate tires.

⚠ WARNING

Do not inflate tire beyond maximum pressure as specified on sidewall. Over inflated tires can blow out, which could result in death or serious injury. (00027b)

⚠ WARNING

Match tires, tubes, rim strips or seals, air valves and caps to the correct wheel. Contact a Harley-Davidson dealer. Mismatching can lead to tire damage, allow tire slippage on the wheel or cause tire failure, which could result in death or serious injury. (00023c)

Check inflation pressure and inspect tread for punctures, cuts, breaks, etc., at least weekly if in daily use. Check before each trip if used occasionally.

⚠ WARNING

Be sure tires are properly inflated, balanced, undamaged, and have adequate tread. Inspect your tires regularly and see a Harley-Davidson dealer for replacements. Riding with excessively worn, unbalanced, improperly inflated, overloaded or damaged tires can lead to tire failure and adversely affect stability and handling, which could result in death or serious injury. (00014b)

Same as original equipment tires should be used. Other tires may not fit correctly, could adversely affect handling, and may be hazardous to use.

⚠ WARNING

Tires are a critical safety component. Contact a Harley-Davidson dealer for tire repair or replacement. Improper tire service can adversely affect stability and handling, which could result in death or serious injury. (00057a)

⚠ WARNING

Replace punctured or damaged tires. In some cases, small punctures in the tread area may be repaired from within the removed tire by a Harley-Davidson dealer. Speed should NOT exceed 80 km/h (50 mph) for the first 24 hours after repair, and the repaired tire should NEVER be used over 129 km/h (80 mph). Failure to follow this warning could lead to tire failure and result in death or serious injury. (00015b)

▲ WARNING

Striking an object, such as a curb or pothole can cause internal tire damage. If an object is struck, have the tire inspected immediately inside and out by a Harley-Davidson dealer. A damaged tire can fail while riding and adversely affect stability and handling, which could result in death or serious injury. (00058b)

TIRE REPLACEMENT

Inspection

▲ WARNING

Replace tire immediately with a Harley-Davidson specified tire when wear bars become visible or only 1 mm (1/32 in) tread depth remains. Riding with a worn tire could result in death or serious injury. (00090c)

See Figure 48. Arrows on tire sidewalls pinpoint location of wear bar indicators.

Tread wear indicator bars will appear on tire tread surfaces when 1/32 in. (0.8 mm) or less of tire tread remains. See Figure 49. Always replace tires before the tread wear indicator bars appear.

When To Replace Tires

New tires are needed if any of the following conditions exist:

1. Tread wear indicator bars become visible on the tread surfaces.
2. Tire cords or fabric become visible through cracked sidewalls, snags or deep cuts.
3. A bump, bulge or split in the tire.
4. Puncture, cut or other damage to the tire that cannot be repaired.

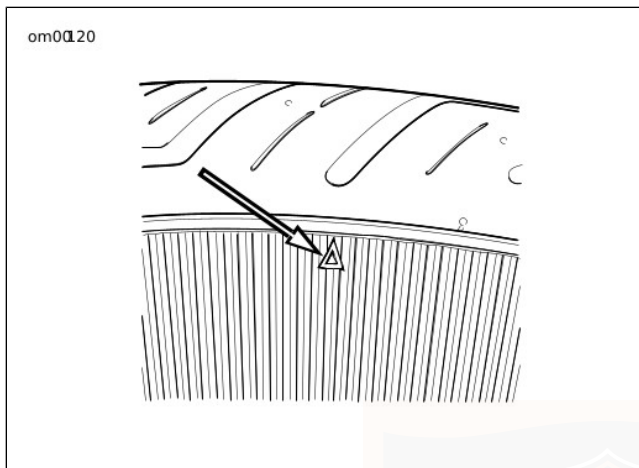

Figure 48. Tire Sidewall

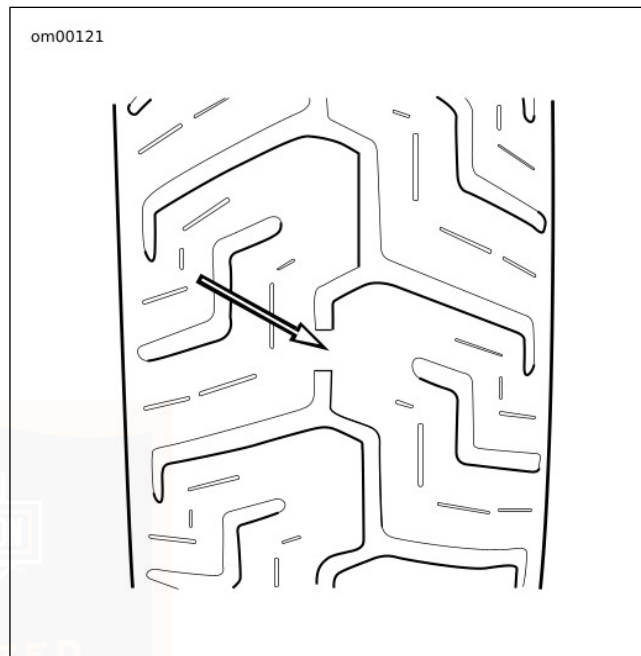

Figure 49. Tread Surface

SHOCK ABSORBERS

Refer to Table 37. Inspect shock absorbers and rubber bushings for leaks and bushing deterioration at proper intervals.

SPARK PLUGS

Refer to Table 37. Check the spark plugs at proper intervals.

▲ CAUTION

Do NOT pull on any electrical wires. Pulling on electrical wires may damage the internal conductor causing high resistance, which may result in minor or moderate injury. (00168a)

Disconnect spark plug cables from plugs by pulling on the molded connector caps. To reconnect, simply snap-on spark plug cables to tops of spark plugs.

Refer to Table 5 before servicing spark plugs.

1. Check spark plug type. Only use those spark plugs specified for your model motorcycle.
2. Check spark plug gap against table specifications.
3. Always tighten to the proper torque. Spark plugs must be tightened to the torque specified for proper heat transfer.

NOTE

If a torque wrench is not available, tighten plugs finger tight and then tighten an additional one quarter turn with a spark plug wrench.

IGNITION

The engine in your motorcycle has been designed specifically to achieve optimum fuel economy within exhaust emission controls. Factory programmed ignition characteristics provide maximum engine performance and driveability.

NOTE

The ignition control unit monitors engine load. In certain transient load conditions (as the throttle is opened), the timing changes from normal to fully advanced. At this point, the operator can sometimes hear a noise that is similar to pre-ignition detonation.

This noise should not be confused with detonation which can be stopped by the use of a higher grade fuel. It is caused by the instant pressure rise in the combustion chambers as the spark advances rapidly. This noise doesn't affect engine performance.

CARBURETOR

The carburetor has been specifically designed for emissions control operation. All jets are fixed at the factory.

Carburetor controls include throttle, enrichener and idle speed adjusting screw. Operation should be checked and adjusted at proper intervals. Refer to Table 37.

NOTICE

Operation at higher altitudes (approximately 4000 ft. (1200 meters) elevation) can require carburetor modifications for best engine performance. See a Harley-Davidson dealer for these adjustments. Failure to do so could result in equipment damage. (00206a)

We recommend that any carburetor service be performed by a Harley-Davidson dealer.

AIR CLEANER

See Figure 50. The engine air cleaner is a paper/wire mesh air filter element.

Refer to Table 37. Remove air cleaner cover and inspect filter element at proper intervals. Under dusty conditions, inspect more often.

The paper/wire mesh air filter element should be washed in luke warm water with a mild detergent.

▲ WARNING

Compressed air can pierce the skin and flying debris from compressed air could cause serious eye injury. Wear safety glasses when working with compressed air. Never use your hand to check for air leaks or to determine air flow rates. (00061a)

- Allow filter to either air dry or blow it dry, from the inside, with low pressure air.
- Do not use an air cleaner filter oil on the Harley-Davidson paper/wire mesh air filter element.

NOTICE

Install air filter before running engine. Failure to do so can draw debris into the engine and could result in engine damage. (00207a)

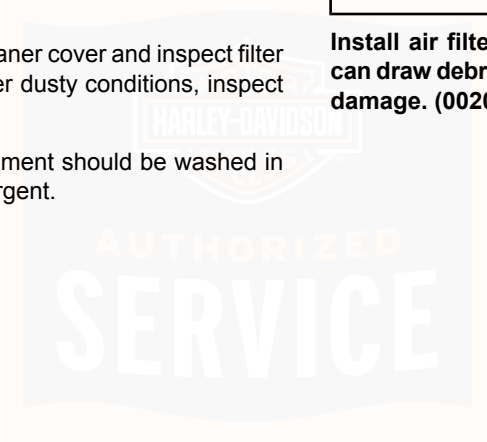

om00208

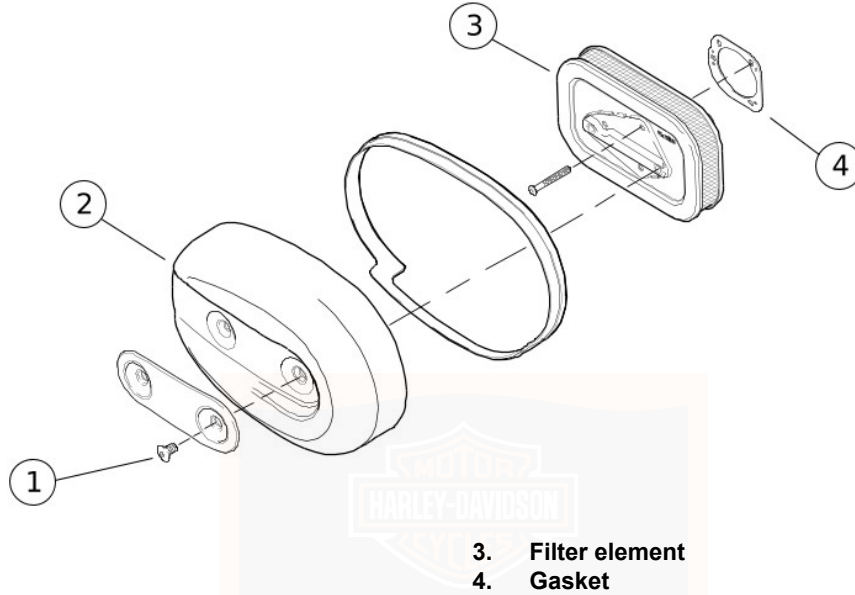

Figure 50. Air Cleaner Assembly: Sportster Models

HEADLAMP

See Figure 51. The headlamp assembly uses a replaceable quartz halogen bulb.

NOTE

Refer to Table 12 and see a service manual for more details.

NOTICE

When replacement is required, use only the specified sealed beam unit or bulb, available from a Harley-Davidson dealer. An improper wattage sealed beam or bulb, can cause charging system problems. (00209a)

NOTICE

Never touch the quartz bulb. Fingerprints will etch the glass and decrease bulb life. Handle the bulb with paper or a clean, dry cloth. Failure to do so could result in bulb damage. (00210b)

▲ WARNING

Handle bulb carefully and wear eye protection. Bulb contains gas under pressure, which, if not handled carefully, could cause serious eye injury. (00062b)



om00209

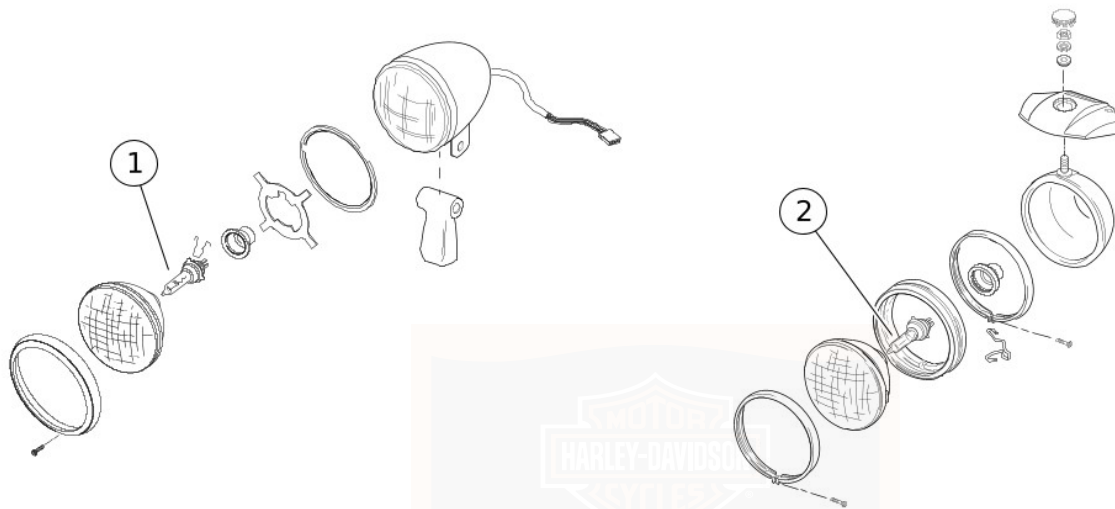

1. XL 883C Custom, XL 1200C Custom

2. XL 883, XL883L, XL883R, XL 1200R Roadster

Figure 51. Headlamp Bulbs: Sportster Models

HEADLAMP ALIGNMENT: SPORTSTER MODELS

⚠ WARNING

The automatic-on headlamp feature provides increased visibility of the rider to other motorists. Be sure headlamp is on at all times. Poor visibility of rider to other motorists can result in death or serious injury. (00030b)

Check headlamp beam for proper height and lateral alignment:

- When the new owner takes delivery of the motorcycle.
- When there is a change in load (adding luggage, etc.).

Inspection

1. Verify correct front and rear tire inflation pressure. Refer to Table 11.
2. Place motorcycle on level floor (or pavement) in an area with minimum light.
3. See Figure 52. Position motorcycle 25 feet (7.62 meters) away a screen or wall. Measure distance from directly below front axle to base of screen/wall.
4. Draw a horizontal line, on screen or wall, 35 inches (0.9 meters) above floor.

5. Load vehicle with rider, passenger (if normally present) and any cargo normally carried. Weight will compress vehicle suspension slightly.
6. Stand motorcycle upright with both tires resting on floor and with front wheel held in straight alignment (directly forward).
7. Turn ignition/headlamp switch to IGNITION position. Set handlebar headlamp switch to HIGH beam position.
8. Check light beam for proper height alignment:
 - a. Main beam of light (broad, flat pattern of light) should be centered equally above and below horizontal line on screen or wall.
 - b. Main beam of light should be directed straight ahead. Properly adjusted headlamps project an equal area of light to right and left of center.
9. Adjust headlamp alignment if necessary.

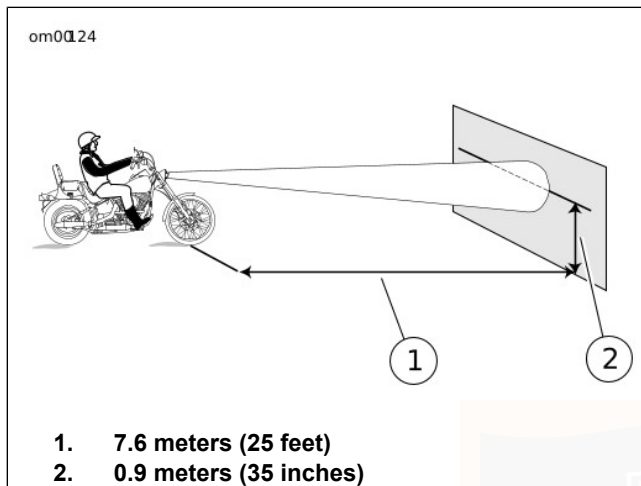

Figure 52. Headlamp Alignment: Sportster Models

Adjustment

1. See Figure 53. Remove snap plug (1) on top of headlamp bracket (2).
2. See Figure 54. Loosen headlamp clamp nut.
3. Tilt headlamp up or down to properly aim it in relation to the horizontal line and, at the same time, turn it right or left to direct light beam straight ahead.

4. Tighten headlamp clamp nut to 14–27 N·m (120–240 in-lbs) after lamp is properly positioned. Install snap plug in headlamp bracket.

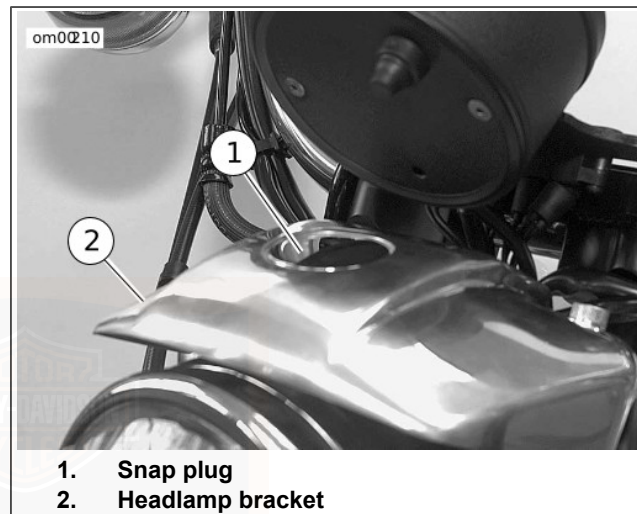

Figure 53. Headlamp Snap Plug: Sportster Models



Figure 54. Headlamp Clamp Nut: Sportster Models
TURN SIGNAL BULBS: BULLET STYLE

Replacement

1. See Figure 55. To access the front or rear turn signal bulbs for replacement, locate a notch on the turn signal lens cap.
2. Insert a coin in the lens cap notch, and carefully twist until the lens cap pops out of the lamp housing.

3. Push in and twist the lamp bulb counterclockwise and pull lamp bulb out of the socket.
4. Orient index pins on **new** lamp bulb with pin guides inside bulb socket.
5. Push lamp bulb in and turn clockwise to lock in place.
6. Snap lens cap back into the lamp holder.

Alignment

Refer to service manual for alignment procedure.

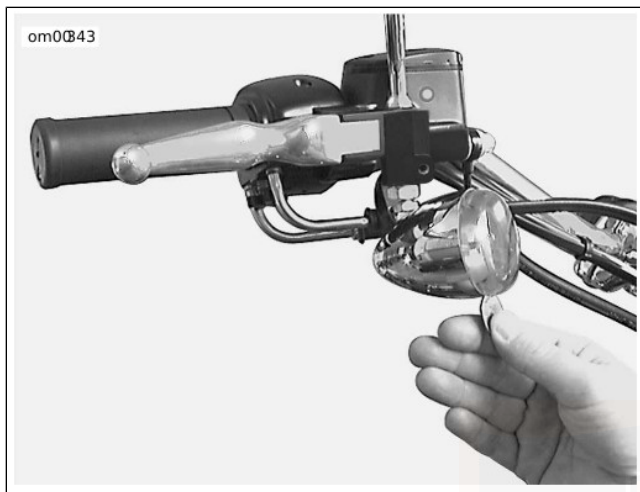

Figure 55. Lens Cap Notch

ALTERNATOR/VOLTAGE REGULATOR

Charging Rate

The alternator output is controlled and changed to direct current by the voltage regulator.

- The voltage regulator increases charging rate when battery is low or lamps are lit.

- The voltage regulator decreases charging rate when no lamps are lighted and when battery charge is up.

NOTICE

It is possible to overload the vehicle's charging system by adding too many electrical accessories. If the combined electrical accessories operating at any one time consume more electrical current than the vehicle's charging system can produce, the electrical consumption can discharge the battery and cause damage to the vehicle's electrical system. (00211d)

A battery voltage LED in the dash will light up when voltage is either too low or too high.

NOTE

- *This unit requires no interval attention. If any electrical system trouble is experienced that might be traceable to the alternator or voltage regulator, the motorcycle should be taken to a Harley-Davidson dealer who has the necessary electrical testing equipment to give the required attention.*
- *For model specific information regarding the voltage regulator, refer to the appropriate Service Manual or see a Harley-Davidson dealer.*

BATTERY: GENERAL

Type

Your motorcycle uses a permanently sealed, maintenance-free, lead/calcium and sulfuric acid battery. All batteries are shipped precharged and ready to be put into service. Do not attempt to open the battery for any reason.

Table 34. Antidotes for Battery Acid

CONTACT	TREATMENT
External	Flush with water.
Internal	Drink large quantities of milk or water, followed by milk of magnesia, vegetable oil or beaten eggs. Get immediate medical attention.
Eyes	Flush with water. Get immediate medical attention.

⚠ WARNING

Batteries contain sulfuric acid, which could cause severe burns to eyes and skin. Wear a protective face shield, rubberized gloves and protective clothing when working with batteries. **KEEP BATTERIES AWAY FROM CHILDREN.** (00063a)

⚠ WARNING

Explosive hydrogen gas, which escapes during charging, could cause death or serious injury. Charge battery in a well-ventilated area. Keep open flames, electrical sparks and smoking materials away from battery at all times. **KEEP BATTERIES AWAY FROM CHILDREN.** (00065a)

⚠ WARNING

Batteries, battery posts, terminals and related accessories contain lead and lead compounds, and other chemicals known to the State of California to cause cancer, and birth defects or other reproductive harm. Wash hands after handling. (00019e)

⚠ WARNING

Never remove warning label from battery. Failure to read and understand all precautions contained in warning, could result in death or serious injury. (00064b)

om00035

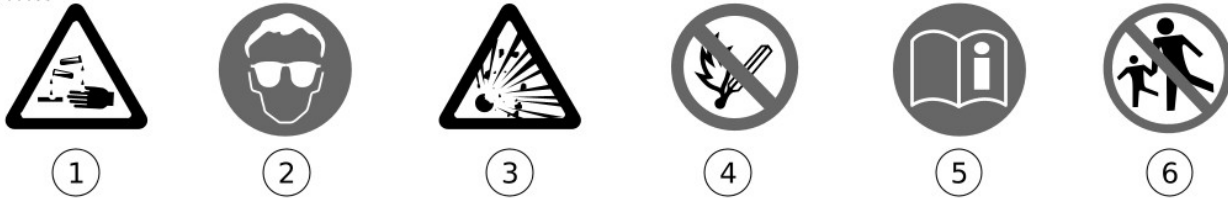

<p>NON-SPILLABLE This is a ready filled, activated, SEALED BATTERY. NEVER remove strip. Refer to owner's manual for charging instructions. If battery is put into service 12 months after date shown, charge for minimum of 1 hour at 6-10 amps. (See side of battery for date.)</p>	     	<p>! DANGER/POISON</p> <table border="1"><tr><td><p>SHIELD EYES. EXPLOSIVE GASES CAN CAUSE BLINDNESS OR INJURY.</p></td><td><p>NO SPARKS FLAMES SMOKING</p></td><td><p>SULFURIC ACID CAN CAUSE BLINDNESS OR SEVERE BURNS.</p></td><td><p>FLUSH EYES IMMEDIATELY WITH WATER. GET MEDICAL HELP FAST.</p></td></tr></table> <p>KEEP OUT OF REACH OF CHILDREN. DO NOT OPEN BATTERY.</p>	 <p>SHIELD EYES. EXPLOSIVE GASES CAN CAUSE BLINDNESS OR INJURY.</p>	 <p>NO SPARKS FLAMES SMOKING</p>	 <p>SULFURIC ACID CAN CAUSE BLINDNESS OR SEVERE BURNS.</p>	 <p>FLUSH EYES IMMEDIATELY WITH WATER. GET MEDICAL HELP FAST.</p>
 <p>SHIELD EYES. EXPLOSIVE GASES CAN CAUSE BLINDNESS OR INJURY.</p>	 <p>NO SPARKS FLAMES SMOKING</p>	 <p>SULFURIC ACID CAN CAUSE BLINDNESS OR SEVERE BURNS.</p>	 <p>FLUSH EYES IMMEDIATELY WITH WATER. GET MEDICAL HELP FAST.</p>			

1. Contents are corrosive
2. Wear safety glasses
3. Contents are explosive
4. Keep flames away
5. Read instructions
6. Keep away from children

Figure 56. Battery Warning Label

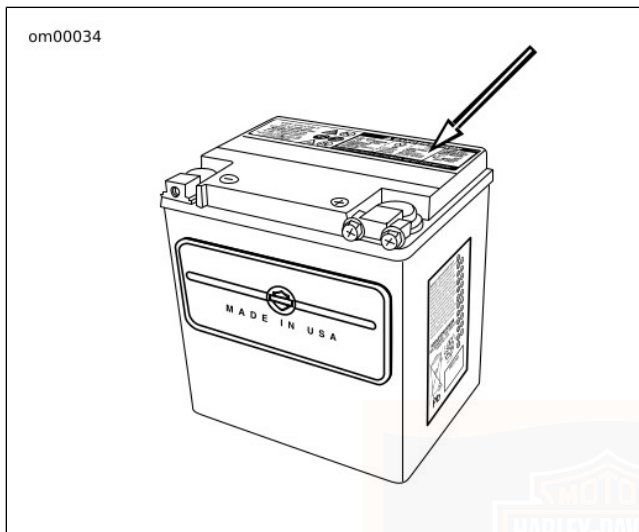

Figure 57. Battery Warning Label Location

Voltmeter Test

You must remove the battery from the vehicle before testing. See MAINTENANCE AND LUBRICATION > BATTERY: SPORTSTER MODELS (Page 127).

Refer to Table 35. The voltmeter test provides a general indicator of battery condition. Check the voltage of the battery to verify that it is in a 100 percent fully charged condition. If

the open circuit (disconnected) voltage reading is below 12.6V, charge the battery and then re-check the voltage after the battery has set for one to two hours.

Table 35. Voltmeter Test

READING IN VOLTS	PERCENT OF CHARGE
12.8	100
12.6	75
12.3	50
12.0	25
11.8	0

Cleaning and Inspection

Battery top must be clean and dry. Dirt and electrolyte on top of the battery can cause battery to self-discharge.

1. Clean battery top with a solution of baking soda (sodium bicarbonate) and water. Use 5 teaspoons baking soda per quart or liter of water.
2. When the solution stops bubbling, rinse off the battery with clean water.
3. Clean cable connectors and battery terminals using a wire brush or fine grit sandpaper to remove any oxidation.
4. Inspect and clean the battery screws, clamps and cables. Check for breakage, loose connections and corrosion.

5. Check the battery posts for melting or damage caused by overtightening.
6. Inspect the battery for discoloration, a raised top or a warped or distorted case. This might indicate that the battery has been frozen, overheated or overcharged.
7. Inspect the battery case for cracks or leaks.

Charging

Never charge a battery without first reviewing the instructions for the charger being used. In addition to the manufacturer's instructions, follow these general safety precautions.

Charge the battery if any of the following conditions exist:

- Vehicle lamps appear dim.
- Electric starter sounds weak.
- Battery has not been used for an extended period of time.

⚠ WARNING

Explosive hydrogen gas, which escapes during charging, could cause death or serious injury. Charge battery in a well-ventilated area. Keep open flames, electrical sparks and smoking materials away from battery at all times. KEEP BATTERIES AWAY FROM CHILDREN. (00065a)

⚠ WARNING

Batteries contain sulfuric acid, which could cause severe burns to eyes and skin. Wear a protective face shield, rubberized gloves and protective clothing when working with batteries. KEEP BATTERIES AWAY FROM CHILDREN. (00063a)

1. Perform a voltmeter test to determine the state of charge. If battery needs to be charged, proceed to the next step.

NOTICE

Remove battery from motorcycle before charging. Electrolyte leakage will damage motorcycle parts. (00213a)

2. Remove the battery from the motorcycle. See MAINTENANCE AND LUBRICATION > BATTERY: SPORTSTER MODELS (Page 127).
3. Place the battery on a level surface.

NOTE

- *The figures listed in the Amp-hour table assume that the battery is charging at room temperature. If warmer than room temperature, use a slightly shorter charging time. If colder, use a slightly longer charging time.*

- *The use of constant current chargers to charge sealed maintenance free batteries is not recommended. Any overcharge will cause dry-out and premature battery failure. If a constant current charger is the only type available, do not exceed the charge times listed in Table 36 and do not continue charging the battery if it gets hot. When charging, never exceed 15 volts.*

⚠ WARNING

Unplug or turn OFF battery charger before connecting charger cables to battery. Connecting cables with charger ON can cause a spark and battery explosion, which could result in death or serious injury. (00066a)

⚠ WARNING

Connect positive (+) battery cable first. If positive (+) cable should contact ground with negative (-) cable connected, the resulting sparks can cause a battery explosion, which could result in death or serious injury. (00068a)

⚠ WARNING

Disconnect negative (-) battery cable first. If positive (+) cable should contact ground with negative (-) cable connected, the resulting sparks can cause a battery explosion, which could result in death or serious injury. (00049a)

NOTICE

Do not reverse the charger connections described in the following steps or the charging system of the motorcycle could be damaged. (00214a)

4. Connect the red battery charger lead to positive (+) terminal of the battery.
5. Connect the black battery charger lead to negative (-) terminal of the battery.

NOTE

If the battery is still in the vehicle, connect the negative lead to the chassis ground. Make sure that the ignition and all electrical accessories are turned off.

6. Step away from the battery and turn on the charger.

⚠ WARNING

Unplug or turn OFF battery charger before disconnecting charger cables from battery. Disconnecting clamps with charger ON can cause a spark and battery explosion, which could result in death or serious injury. (00067a)

7. After the battery is fully charged, turn OFF the charger and disconnect the black battery charger lead to the negative (-) terminal of the battery.
8. Disconnect the red battery charger lead to the positive (+) terminal of the battery.
9. Mark the charging date on the battery.

Table 36. 12 Amp-Hour Battery Charging Rates and Times

READING (VOLTS)	PERCENT CHARGE	3 AMP CHARGER	6 AMP CHARGER	10 AMP CHARGER	20 AMP CHARGER
12.8	100	N/A	N/A	N/A	N/A
12.6	75	1 hour 20 minutes	40 minutes	25 minutes	12 minutes
12.3	50	2 hours 40 minutes	80 minutes	50 minutes	25 minutes
12.0	25	4 hours	2 hours	1 hour 10 minutes	40 minutes
11.8	0	5 hours 20 minutes	2 hours 40 minutes	1 hour 40 minutes	50 minutes

Storage

NOTICE

Turn engine over a few times to be sure there is no oil in the crankcase and that all oil has been pumped back into the oil tank. Stop engine and re-check oil level. Failure to do so can result in engine damage. (00071a)

NOTICE

Do not allow battery to completely discharge. The electrolyte in a discharged battery will freeze. The more discharged a battery is, the more easily it can freeze and crack the battery case. (00218a)

If the motorcycle will not be operated for several months, such as during the winter season, remove the battery from the motorcycle and fully charge.

Self-discharge is a normal condition and occurs continuously. The rate of self-discharge depends on the ambient temperature and the battery's state of charge.

- Batteries discharge at a faster rate at higher ambient temperatures.
- To reduce the self-discharge rate, store battery in a cool (not freezing), dry place.

- Charge the battery every month if stored at temperatures below 60° F. (16° C).
- Charge the battery more frequently if stored in a warm area above 60° F. (16° C).

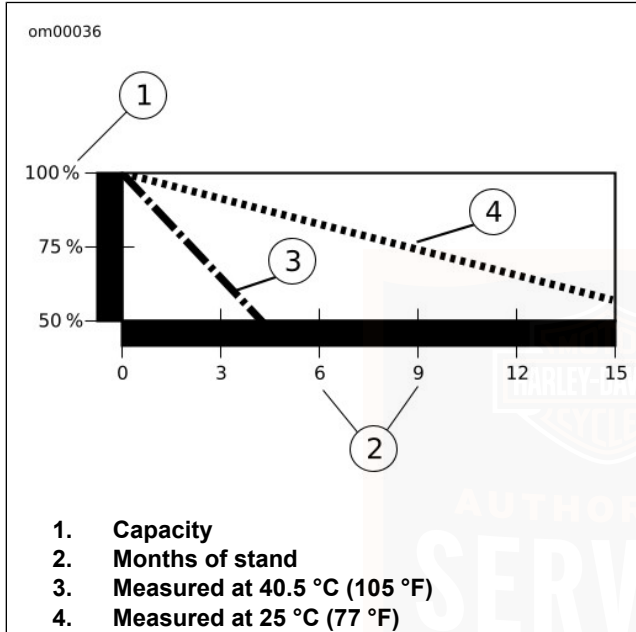

Figure 58. Effective Rate of Temperature on Battery Self-discharging Rate

BATTERY: SPORTSTER MODELS

Disconnection and Removal

⚠ WARNING

Disconnect negative (-) battery cable first. If positive (+) cable should contact ground with negative (-) cable connected, the resulting sparks can cause a battery explosion, which could result in death or serious injury. (00049a)

1. See Figure 59. Unthread nut and remove battery negative cable (black) from crankcase stud behind starter motor assembly.
2. Remove left side cover.
3. Remove Maxi-Fuse and holder from battery strap by grasping holder and sliding it toward the rear of the motorcycle. Then remove Maxi-Fuse holder from its mounting pin on battery strap.
4. Remove battery strap screw and flat washer. Unhook battery strap from battery tray mount on top of battery and remove strap.
5. Unthread bolt and remove battery positive cables (red) from battery positive (+) terminal.

6. Remove battery and attached negative cable as an assembly from the battery tray.

Installation and Connection

NOTICE

Connect the cables to the correct battery terminals. Failure to do so could result in damage to the motorcycle electrical system. (00215a)

⚠ WARNING

Connect positive (+) battery cable first. If positive (+) cable should contact ground with negative (-) cable connected, the resulting sparks can cause a battery explosion, which could result in death or serious injury. (00068a)

⚠ WARNING

Do not allow positive (+) battery cable to contact ground with negative (-) cable connected. Resulting sparks can cause a battery explosion, which could result in death or serious injury. (00069a)

1. Apply a light coat of petroleum jelly or corrosion retardant material to negative (-) battery terminal before installation.
2. Place the fully charged battery with the negative cable attached into the battery tray.

3. See Figure 59. Route negative cable around frame downtube.

NOTICE

Do not over-tighten bolts on battery terminals. Use recommended torque values. Over-tightening battery terminal bolts could result in damage to battery terminals. (00216a)

4. With negative (-) cable disconnected from grounding point on crankcase, insert bolt through Maxi-Fuse cable first then through main battery positive cable (+) (red) and into threaded hole of battery positive (+) terminal.
5. Tighten bolt to 4.5–5.7 N·m (45–50 in-lbs).
6. Apply a light coat of petroleum jelly or corrosion retardant material to positive (+) battery terminal. Place protective rubber boot over terminal.

NOTICE

Keep battery clean and lightly coat terminals with electrical contact lubricant to prevent corrosion. Failure to do so could result in damage to battery terminals. (00217b)

7. Hook top of battery strap to battery tray mount on top of battery. Install flat washer and strap screw.
8. Tighten the strap screw to 4.07–6.78 N·m (36–60 **in-lbs**).
9. Route main positive battery cable through holders on electrical bracket.
10. Hook Maxi-Fuse holder to pin on battery strap and slide forward until it snaps into place.
11. Place negative battery cable end onto stud on crankcase boss behind starter motor assembly . Thread nut onto stud.
12. Tighten nut to 6.2–8.5 N·m (55–75 **in-lbs**).
13. Install left side cover.

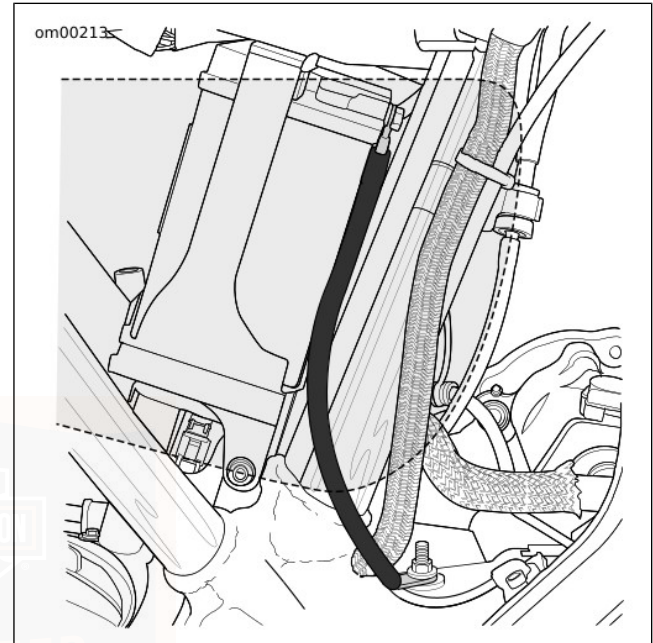

**Figure 59. Negative Battery Cable and Crankcase Stud:
Sportster Models**

JUMP STARTING

Harley-Davidson does not recommend jump-starting a motorcycle. However, there may be circumstances when it is

necessary to do so. Therefore, we suggest jump-starting be performed as follows:

⚠ WARNING

Be sure jumper cables touch only appropriate battery terminals or ground. Allowing jumper cables to touch each other can result in sparks and a battery explosion, which could result in death or serious injury. (00072a)

⚠ WARNING

Explosive hydrogen gas, which escapes during charging, could cause death or serious injury. Charge battery in a well-ventilated area. Keep open flames, electrical sparks and smoking materials away from battery at all times. KEEP BATTERIES AWAY FROM CHILDREN. (00065a)

NOTICE

Be sure both vehicles have the same battery voltage when jump starting. Connecting vehicles with different system voltages can result in vehicle damage. (00220c)

NOTE

This procedure presumes the BOOSTER battery is in another vehicle.

1. Turn off all unnecessary lamps and accessories.

Positive Cable

1. See Figure 60. Connect one end of a jumper cable to the DISCHARGED battery positive (+) terminal (1).
2. Connect the other end of the same cable to the BOOSTER battery positive (+) terminal (2).

Negative Cable

⚠ WARNING

Do not connect negative (-) cable to or near the discharged battery negative (-) terminal. Doing so could cause a spark and explosion, which could result in death or serious injury. (00073a)

1. Connect one end of a jumper cable to the BOOSTER battery negative (-) terminal (3).

NOTICE

Do not connect the negative (-) cable to painted or chrome parts. Doing so could result in discoloration at the attachment point. (00221a)

2. Connect other end of the same cable (4) to a safe ground, (away from the DISCHARGED battery).

3. Start motorcycle.
4. Disconnect cables in reverse order of steps 2, 3, 4, 5.
That is: steps 5, 4, 3, 2.

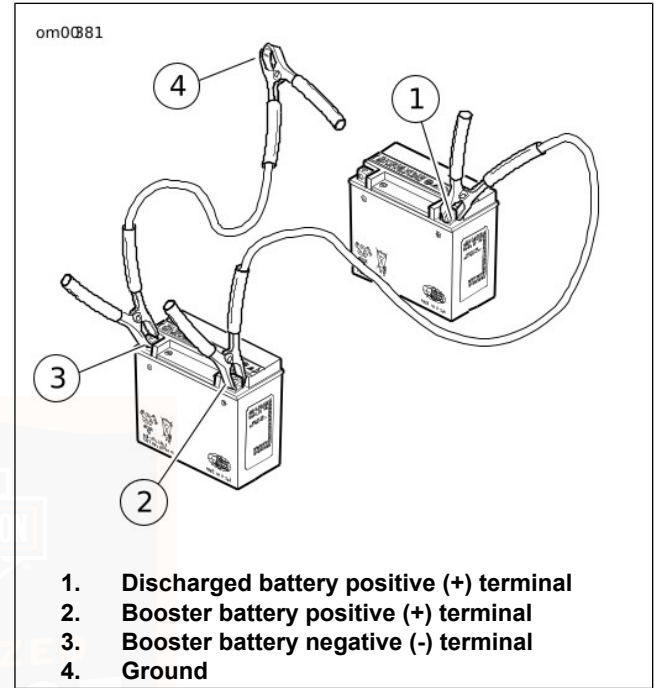
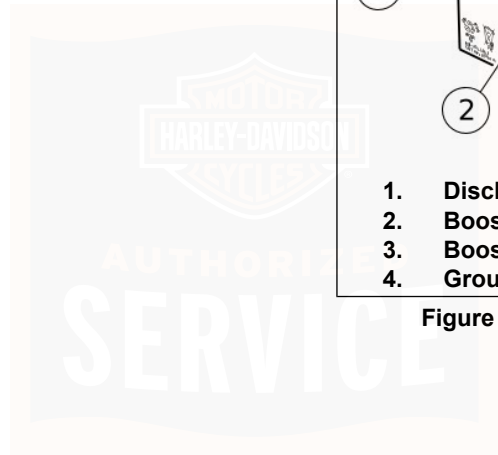

Figure 60. Jump Start Cable Connections



ELECTRICAL PROTECTION: SPORTSTER MODELS

Fuse Replacement

1. Turn the ignition to the OFF position.
2. See Figure 61. Gently pull on upper portion of left side cover pulling cover away from clips. Lift cover from frame.

NOTE

No tools are required to remove or reinstall the side cover.

3. Replace the fuse if the element is burned or broken.

NOTE

Automotive type ATO fuses are used for installation and replacement.

NOTICE

Always use replacement fuses that are of the correct type and amperage rating. Use of incorrect fuses can result in damage to electrical systems. (00222a)

4. Slide fuse block into holder until latch fully engages tab on holder.

5. See Figure 63. Place bottom of side cover with grommet in frame and press top of side cover into clips until snug.

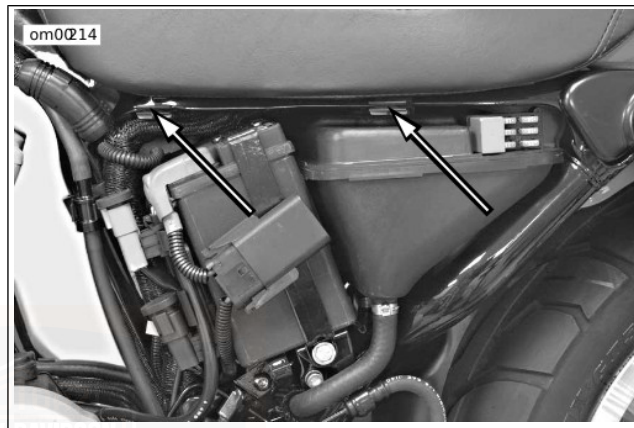

Figure 61. Side Cover Clips: Sportster Models

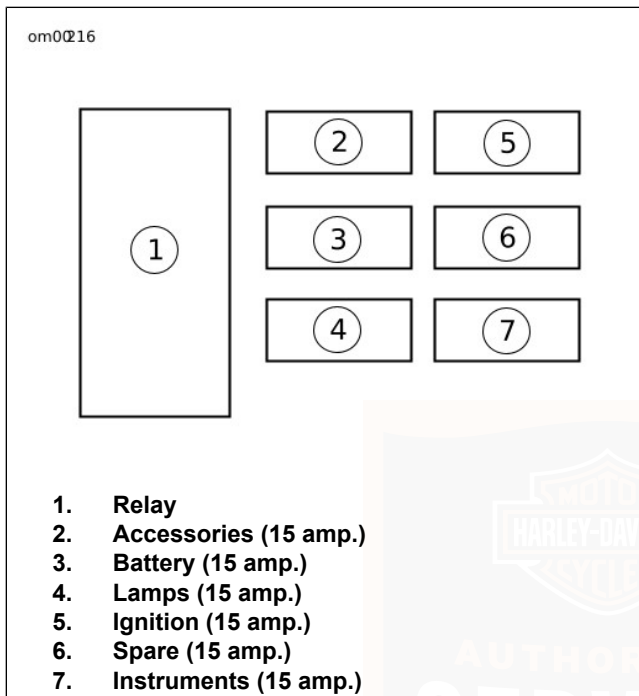

Figure 62. Fuse Block: Sportster Models

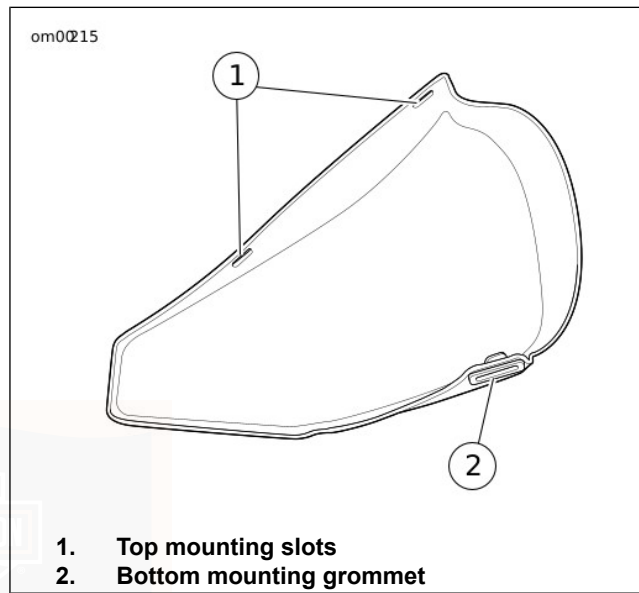

Figure 63. Side Cover: Sportster Models

Replacing the Maxi-Fuse

See Figure 64. All Sportster models have a main fuse to protect the motorcycle wiring. This 30 amp maxi-fuse provides main battery power to the motorcycle. It is located in a rubber-coated fuse holder behind the motorcycle's left side cover.

1. See Figure 61. Gently pull on upper portion of left side cover pulling cover away from clips. Lift cover from frame.
2. Grasp the fuse holder in one hand and the plastic body of the maxi-fuse in the other. Pull the maxi-fuse straight out of the fuse holder.
3. See Figure 65. Insert the prongs of the **new** maxi-fuse in the fuse holder slots. Push the maxi-fuse firmly down into the fuse holder.
4. See Figure 63. Place bottom of side cover with grommet in frame and press top of side cover into clips until snug.

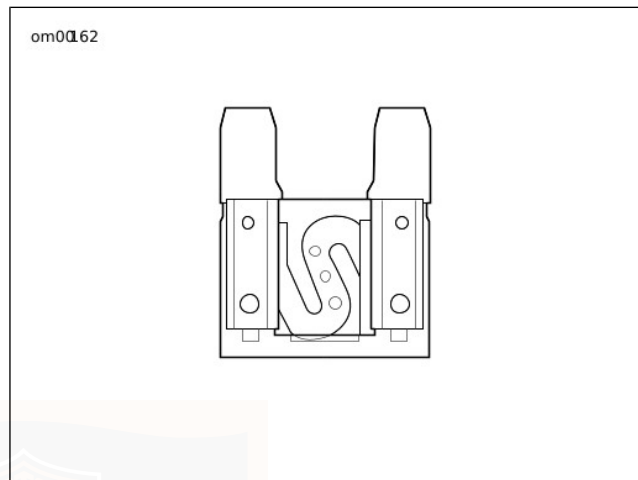

Figure 64. Maxi-Fuse



**Figure 65. Maxi-Fuse Replacement: Sportster Models
SEAT: SPORTSTER MODELS**

Removal

See Figure 66. All Sportster models have a forward tab underneath the seat on the frame back.

1. Remove screw to detach seat from rear fender.
2. Push seat forward to release keyhole from post on frame.
3. Lift up on seat to release tongue from frame.
4. If applicable, inspect passenger strap for damage or excessive wear.

NOTE

The passenger straps are secured to the seat.

Installation

1. See Figure 66. Slide seat forward until the tongue (1) fits snugly in frame.
2. Push seat forward and press firmly in center until keyhole (2) on underside of seat locks firmly to post on frame.

▲ WARNING

After installing seat, pull upward on seat to be sure it is locked in position. While riding, a loose seat can shift causing loss of control, which could result in death or serious injury. (00070b)

3. Pull up on seat to verify that it is locked in place.
4. Install screw and fasten seat mounting bracket to top of rear fender.
5. Tighten mounting bracket screw.
6. Pull up on seat again to verify that it is properly secured, in all three mounting points.

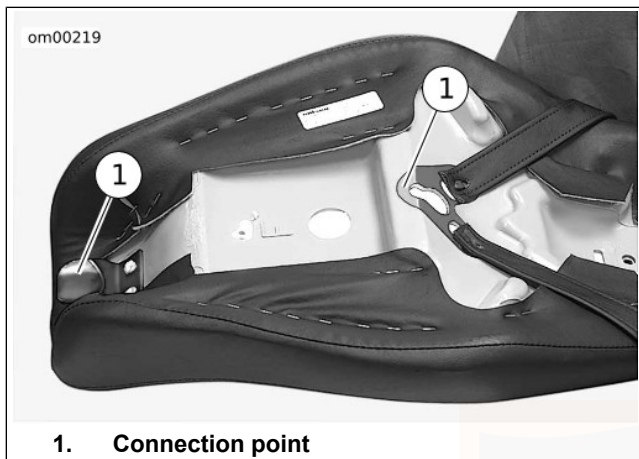

1. Connection point

Figure 66. Seat: Sportster Models

MOTORCYCLE STORAGE

Placing Motorcycle in Storage

NOTICE

Proper storage is important for the trouble-free operation of your motorcycle. See your Owner's Manual for storage recommendations or see a Harley-Davidson dealer. Improper storage procedures can lead to equipment damage. (00046a)

If the motorcycle will not be operated for several months, such as during the winter season, there are several tasks which should be performed. These steps will protect parts against corrosion, preserve the battery and prevent the build-up of gum and varnish in the fuel system.

⚠ WARNING

Do not store motorcycle with gasoline in tank within the home or garage where open flames, pilot lights, sparks or electric motors are present. Gasoline is extremely flammable and highly explosive, which could result in death or serious injury. (00003a)

NOTE

Make a list of everything you do and fasten it to a handgrip. When you take the motorcycle out of storage, this list will be your reference/checklist to get your motorcycle in operating condition.

1. Fill fuel tank and add a gasoline stabilizer. Use one of the commercially available gasoline stabilizers and follow the manufacturer's instructions.
2. Warm motorcycle to operating temperature. Change oil and turn engine over to circulate the new oil.
3. Turn fuel supply valve OFF (if applicable).

4. Adjust the belt.
5. Check tire inflation. Adjust to proper inflation pressure.
6. To protect the vehicle's body panels, engine, chassis and wheels from corrosion, follow the cosmetic care procedures described in the Accessory Maintenance section of this owner's manual prior to storage.
7. Prepare battery for winter storage. See MAINTENANCE AND LUBRICATION > BATTERY: GENERAL (Page 121).

⚠ WARNING

Explosive hydrogen gas, which escapes during charging, could cause death or serious injury. Charge battery in a well-ventilated area. Keep open flames, electrical sparks and smoking materials away from battery at all times. KEEP BATTERIES AWAY FROM CHILDREN. (00065a)

8. If the motorcycle is to be stored with security system armed, it will be necessary to connect a Battery Tender to maintain battery charge. If security system will not be armed and a Battery Tender is not available, either:
 - a. Disconnect negative battery cable.

- b. Remove Maxi-fuse (if applicable).

9. If motorcycle is to be covered, use a material such as light canvas that will breathe. Plastic materials that do not breathe promote the formation of condensation.

Removing Motorcycle From Storage

⚠ WARNING

The clutch failing to disengage can cause loss of control, which could result in death or serious injury. Prior to starting after extended periods of storage, place transmission in gear and push vehicle back and forth several times to assure proper clutch disengagement. (00075a)

1. See MAINTENANCE AND LUBRICATION > BATTERY: GENERAL (Page 121) for proper battery care. Charge and install the battery.
2. Remove and inspect the spark plugs. Replace if necessary.
3. Clean the air cleaner element.
4. Start the engine and run until it reaches normal operating temperature. Turn off engine.

5. Check amount of oil in the oil tank.
6. Check the transmission lubricant level.
7. Check controls to be sure they are operating properly. Operate the front and rear brakes, throttle, clutch and shifter.
8. Check steering for smoothness by turning the handlebars through the full operating range.
9. Check tire pressure. Incorrect pressure will result in poor riding characteristics and can affect handling and stability.
10. Check all electrical equipment and switches including the stop lamp, turn signals and horn for proper operation.
11. Check for any fuel, oil or brake fluid leaks.

⚠ WARNING

Be sure tires are properly inflated, balanced, undamaged, and have adequate tread. Inspect your tires regularly and see a Harley-Davidson dealer for replacements. Riding with excessively worn, unbalanced, improperly inflated, overloaded or damaged tires can lead to tire failure and adversely affect stability and handling, which could result in death or serious injury. (00014b)

NOTICE

Turn engine over a few times to be sure there is no oil in the crankcase and that all oil has been pumped back into the oil tank. Stop engine and re-check oil level. Failure to do so can result in engine damage. (00071a)

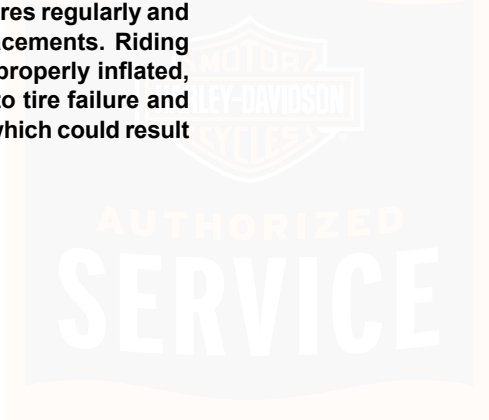

GENERAL MAINTENANCE

Maintain chrome and aluminum regularly to check that they retain their original shine and luster. Take care to keep your new Harley-Davidson motorcycle cleaned and waxed as often as possible to inhibit rust and corrosion.

CLEANING YOUR MOTORCYCLE

To aid you in keeping your motorcycle clean, see your Harley-Davidson dealer for cleaning, polishing and waxing products.

Harley-Davidson recommends the following products:

- SUNWASH (Part No. 94659-98): for general cleaning/washing of all surfaces.
- BUG REMOVER (Part No. 94657-98): for removing bugs from all surface finishes.
- HARLEY SPRAY CLEANER (Part No. 99817-99): all purpose cleaner and quick detailer for metal surfaces.
- HARLEY GLOSS (Part No. 94627-98): all purpose surface protectant provides UV protection and a gloss finish.

⚠ WARNING

Observe warnings on labels of cleaning compounds. Failure to follow warnings could result in death or serious injury. (00076a)

⚠ WARNING

Do not wash brake discs with cleaners containing chlorine or silicone. Cleaners containing chlorine and silicone can impair brake function, which could result in death or serious injury. (00077a)

⚠ WARNING

Do not let the brakes, engine, mufflers or air cleaner to get wet when washing your motorcycle. Allowing these components to get too wet can adversely affect their performance, which could result in death or serious injury. Start engine immediately after washing, and make sure brakes and engine are operating properly before riding in traffic. (00078b)

LEATHER CARE

NOTE

Many Harley-Davidson accessories and seats are either made of leather or have leather inserts. Natural materials age differently and require different care than man-made materials. Seat covers and panels made of leather will gain "character", such as wrinkles, with age. Leather is porous and organic and each leather product will settle into its own distinct form with use. Your leather product will mature into its own custom shape and style from the sun, rain and the miles. This maturing is natural and will enhance the custom quality of your Harley-Davidson motorcycle.

Leather must be periodically cleaned and treated to maintain its appearance and extend its life. Clean and treat leather once a season or more frequently under adverse conditions.

NOTICE

Do not use bleach or detergents containing bleach on saddlebags, seats, tank panels or painted surfaces. Doing so can result in equipment damage. (00229a)

- Do not use ordinary soap to clean leather or fur. It could dry or remove the oils from the leather.
 - Use ONLY a good quality saddle soap to clean leather. Be sure you rinse saddle soap off thoroughly before treating leather.
 - Never try to dry leather quickly, using artificial means. Always let leather dry naturally, at room temperature.
1. Vacuum or blow dust off.
 2. Thoroughly clean leather with a good quality saddle soap, following manufacturer's directions. Rinse thoroughly with clean sponge or cloth and water. Allow leather to dry.
 3. Once leather is dry, treat with a good quality leather treatment, such as LEATHERCARE (Part No. 98261-91).
 4. Always allow leather to dry completely before using.

WHITEWALL TIRES

Use a good quality, commercial whitewall cleaner and follow the manufacturer's directions.

WHEEL CARE

▲ WARNING

Be careful not to get the brakes wet when washing vehicle. Wet brake pads and/or discs can adversely affect brake performance, which could result in death or serious injury. (00079b)

Some vehicle's wheels are aluminum and do not have a protective coating. Other vehicles have laced wheels with chrome plated rims and zinc or chrome plated spokes. Damage from harsh chemicals, acid based wheel cleaners, brake dust and lack of maintenance can occur. Regular washing and the use of a corrosion protectant will help to maintain their original appearance. Harley-Davidson WHEEL AND TIRE CLEANER (Part No. 94658-98) is recommended for cleaning wheels and tires. Then use HARLEY GLOSS (Part No. 94627-98) to protect the wheel surfaces.

NOTE

- *It is imperative that the wheels are cared for weekly to guard against pitting and corrosion.*

- *Corrosion of these components is not considered to be a defect in materials or workmanship.*

Harley-Davidson recommends the following products:

- WHEEL AND TIRE CLEANER (Part No. 94658-98): cleaner/degreaser for wheels, tires and engine.
- HARLEY GLOSS (Part No. 94627-98): all purpose surface protection the provides UV protection and a gloss finish.

See a Harley-Davidson dealer for cleaning, polishing and waxing products.

WINDSHIELDS

NOTICE

Harley-Davidson windshields are made of Lexan. Lexan is a more durable and distortion-resistant material than other types of motorcycle windshield material, but still requires attention and care to maintain. Failure to maintain Lexan properly can result in damage to the windshield. (00230b)

NOTICE

Use only Harley-Davidson recommended products on Harley-Davidson windshields. Do not use harsh chemicals or rain sheeting products, which can cause windshield surface damage, such as dulling or hazing. (00231c)

NOTICE

Do not use benzine, paint thinner, gasoline or any other type of harsh cleaner on the windshield. Doing so will damage the windshield surface. (00232c)

NOTE

- *To remove minor surface scratches use NOVUS No. 2 SCRATCH REMOVER (Part No. 99836-94T).*
- *Covering the windshield with a clean, wet cloth for approximately 15-20 minutes before washing will make dried bug removal easier.*

1. Use mild soap and warm water to wash the windshield.
2. Wipe dry with a soft, clean towel.

NOTE

To treat your Lexan windshield with water repellent use WINDSHIELD WATER REPELLENT TREATMENT (Part No. 99841-02).

NOTES



TROUBLESHOOTING: GENERAL

⚠ WARNING

The troubleshooting section of the Owner's Manual is a guide to diagnose problems. Read the service manual before performing any work. Improper repair and/or maintenance could result in death or serious injury. (00080a)

The following checklist of possible operating troubles and their probable causes will be helpful in keeping your motorcycle in good operating condition. More than one of these conditions may be causing trouble and should be carefully checked.

ENGINE

Starter Does Not Operate or Does Not Turn Engine Over

1. Engine run switch in OFF position.
2. Ignition switch not ON.
3. Discharged battery or loose or corroded connections (solenoid chatters).

Engine Turns Over But Does Not Start

1. Fuel tank empty.

2. Fuel valve turned OFF (If applicable).
3. Fuel vacuum line disconnected (If applicable).
4. Fuel valve or filter clogged (If applicable).
5. Discharged battery or loose or broken battery terminal connections.
6. Fouled spark plugs.
7. Spark plug cable connections loose or in bad condition and shorting.
8. Loose or corroded wire or cable connection(s) at coil or battery.
9. Engine flooded with fuel as a result of over-enrichening.
10. Throttle held open when enrichener is used (If applicable).
11. Fuel pump inoperative (If applicable).

Starts Hard

1. Spark plugs in bad condition, have improper gap, or are partially fouled.
2. Spark plug cables in bad condition and leaking.
3. Battery nearly discharged.
4. Loose wire or cable connection(s) at one of the battery terminals or at coil.
5. Carburetor not adjusted correctly (If applicable).

6. Engine oil too heavy (winter operation).
7. Fuel tank vent plugged or fuel line closed off, restricting fuel flow.
8. Water or dirt in fuel system.
9. Fuel pump inoperative (If applicable).

Starts But Runs Irregularly or Misses

1. Spark plugs in bad condition or partially fouled.
2. Spark plug cables in bad condition and leaking.
3. Spark plug gap too close or too wide.
4. Battery nearly discharged.
5. Damaged wire or loose connection at battery terminals or coils.
6. Intermittent short circuit due to damaged wire insulation.
7. Water or dirt in fuel system, filter or carburetor.
8. Fuel vent system plugged. See dealer.
9. One or more injectors fouled.

A Spark Plug Fouls Repeatedly

1. Excessive enrichener use (If applicable).
2. Fuel mixture too rich (If applicable).

3. Incorrect spark plug.

Pre-ignition or Detonation (Knocks or Pings)

1. Incorrect fuel.
2. Incorrect spark plug for the kind of service.

Overheats

1. Insufficient oil supply or oil not circulating.
2. Heavy carbon deposit from lugging engine. See dealer.
3. Insufficient air flow over cylinder heads during extended periods of idling or parade duty.

Excessive Vibration

1. Rear fork pivot shaft nuts loose. See dealer.
2. Front engine mounting bolts loose. See dealer.
3. Engine to transmission mounting bolts loose. See dealer.
4. Broken frame. See dealer.
5. Front chain or links tight as a result of insufficient lubrication or belt badly worn.
6. Wheels and/or tires damaged. See dealer.
7. Vehicle not properly aligned. See dealer.

ELECTRICAL SYSTEM

Alternator Does Not Charge

1. Module not grounded. See dealer.
2. Engine ground wire loose or broken. See dealer.
3. Loose or broken wires in charging circuit. See dealer.

Alternator Charge Rate is Below Normal

1. Weak battery.
2. Excessive use of add-on accessories.
3. Loose or corroded connections.
4. Extensive periods of idling or low speed riding.

CARBURETOR

Carburetor Floods

1. Excessive rolling of hand throttle grip.

TRANSMISSION

Transmission Shifts Hard

1. Bent shifter rod. See dealer.
2. Transmission shifting mechanism needs adjustment. See dealer.

Transmission Jumps Out of Gear

1. Shifter rod improperly adjusted. See dealer.
2. Shifter forks (inside transmission) improperly adjusted. See dealer.
3. Worn shifter dogs in transmission. See dealer.

Clutch Slips

1. Clutch controls improperly adjusted. See dealer.
2. Worn friction discs. See dealer.
3. Insufficient clutch spring tension. See dealer.

Clutch Drags or Does Not Release

1. Clutch controls improperly adjusted. See dealer.
2. Insufficient clutch spring tension. See dealer.
3. Primary chaincase overfilled.
4. Clutch discs warped. See dealer.

Clutch Chatters

1. Friction discs or steel discs worn or warped. See dealer.

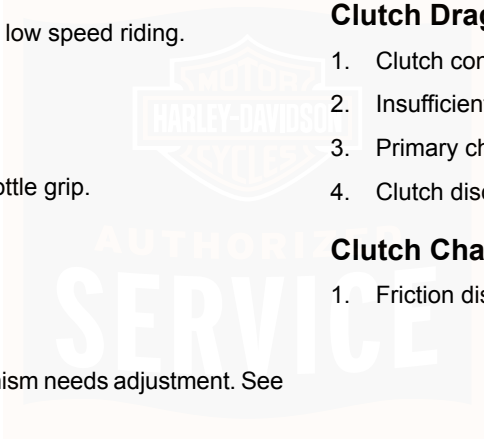

BRAKES

Brakes Do Not Hold Normally

1. Master cylinder low on fluid. See dealer.
2. Brake line contains air bubbles. See dealer.
3. Master or wheel cylinder piston worn. See dealer.
4. Brake pads contaminated with grease or oil. See dealer.
5. Brake pads badly worn. See dealer.
6. Brake disc badly worn or warped. See dealer.
7. Brake fades because of heat build up. Excessive braking or brake pads dragging. See dealer.
8. Brake drags. Insufficient hand lever free play. See dealer.



WARRANTY AND MAINTENANCE

This Owner's Manual contains your new motorcycle warranty.

It is the owner's responsibility to follow the scheduled mileage intervals as specified; all of the specified maintenance services must be performed to keep your warranty valid.

1. Make an appointment with a Harley-Davidson dealer for inspection and service just before you have ridden 1000 miles (1600 kilometers).
2. Bring this Owner's Manual with you when you visit your dealer to have your motorcycle inspected and serviced.
3. Have the dealer technician sign at the proper mileage interval. The records should be retained by the owner as proof of proper maintenance.
4. Keep receipts covering any parts, service or maintenance performed. These records should be transferred to each subsequent owner.

⚠ WARNING

Harley-Davidson parts and accessories are designed for Harley-Davidson motorcycles. Using non-Harley-Davidson parts or accessories can adversely affect performance, stability or handling, which could result in death or serious injury. (00001b)

Harley-Davidson dealerships are independently owned and operated and may sell parts and accessories that are not manufactured or approved by Harley-Davidson. Therefore, you should understand that we are not and cannot be responsible for the quality, suitability, or safety of any non-Harley-Davidson part, accessory or design modification, including labor, which may be sold and/or installed by our dealers.

KEEPING IT ALL HARLEY-DAVIDSON

1. Keep your Harley-Davidson completely Harley-Davidson.
2. Insist that your dealer uses only Genuine replacement parts to keep your Harley-Davidson motorcycle and its warranty intact.

Exact design and stringent testing ensure performance and warranty coverage. Again, insist on Genuine parts for your genuine Harley-Davidson motorcycle.

NOTE

Installing off-road or competition parts to enhance performance may void all or part of your new motorcycle warranty. See the Harley-Davidson Limited Warranty in this manual or a Harley-Davidson dealer for details.

NOTICE

It is possible to overload the vehicle's charging system by adding too many electrical accessories. If the combined electrical accessories operating at any one time consume more electrical current than the vehicle's charging system can produce, the electrical consumption can discharge the battery and cause damage to the vehicle's electrical system. (00211d)

IMPORTANT MOVING INFORMATION

If you move from your present address, or sell your motorcycle, please fill out and mail the post card at the back of this manual. This is necessary in the event that the Company needs to contact the owner concerning information that could affect the safe operation of this motorcycle.

WARRANTY/SERVICE INFORMATION

Any authorized Harley-Davidson dealer is responsible for providing the warranty repair work on your motorcycle. If you have any questions regarding warranty obligations contact your selling dealer.

For normal service work or warranty work under the above conditions, you may obtain the name and location of your nearest U.S. Harley-Davidson dealer by calling

1-800-490-9635 (toll free), in any state except Alaska and Hawaii.

NOTE

The number shown above is accessible only with a touch-tone phone.

OWNER TRANSFER IDENTIFICATION FORM

When purchasing a pre-owned Harley-Davidson or Buell, we encourage you to submit an Owner Transfer Notification Form. It is critical that new owner information is communicated to Harley-Davidson. New owner information is required to be on file with Harley-Davidson to transfer an Extended Service Plan Contract. Harley-Davidson is also required by the National Traffic and Motor Vehicle Safety Act to notify all owners in the event of a recall. The form may be obtained at any Harley-Davidson dealer.

REQUIRED DOCUMENTATION FOR IMPORTED MOTORCYCLES

If a Harley-Davidson is imported into the United States, additional documentation is required to be eligible for the United States Manufacturer's Limited Warranty. A Harley-Davidson dealer can provide a form explaining the requirements.

2005 HARLEY-DAVIDSON MOTORCYCLE LIMITED WARRANTY

24 Months/Unlimited Miles

Harley-Davidson warrants for any new 2005 Harley-Davidson motorcycle/sidecar that an authorized Harley-Davidson dealer will repair or replace without charge any parts found under normal use to be defective in factory materials or workmanship. Such repair and replacement will be Harley-Davidson's sole obligation and the customer's sole remedy under this warranty.

THERE IS NO OTHER EXPRESS WARRANTY (OTHER THAN THE SEPARATE EMISSIONS AND NOISE WARRANTIES) ON THE MOTORCYCLE. ANY IMPLIED WARRANTY OF MERCHANTABILITY OR FITNESS FOR PARTICULAR PURPOSE IS LIMITED TO THE DURATION OF THIS WARRANTY.

Some states do not allow limitations on how long an implied warranty lasts, so the above limitation may not apply to you.

The following terms and conditions apply to this warranty:

Duration

1. The duration of this limited warranty is twenty four months, measured from the date of initial retail purchase and delivery from an authorized Harley-Davidson dealer. Your dealer will submit an electronic Sales and Warranty Registration form to initiate your warranty.
2. Any unexpired portion of this limited warranty will be transferred to subsequent owners, upon the resale of the motorcycle/sidecar during the warranty period.

Owner's Obligations

To obtain warranty service, return your motorcycle/sidecar at your expense within the warranty period to an authorized dealer. Our dealer should be able to provide warranty service during normal business hours and as soon as possible, depending upon the workload of the dealer's service department and the availability of necessary parts.

Harley-Davidson Motor Company, P.O. Box 653, Milwaukee, Wisconsin 53201, U.S.A.

Exclusions

This warranty will not apply to any motorcycle/sidecar as follows:

1. Which has not been operated or maintained as specified in the Owner's Manual.

2. Which has been abused, misused, improperly stored, used "off the highway," or used for racing or competition of any kind.
3. Which is not manufactured to comply with the laws of the market in which it is registered.
4. Installing off-road or competition parts to enhance performance may void all or part of your new motorcycle warranty. See a Harley-Davidson dealer for details.
3. Any cosmetic condition existing at the time of retail delivery that has not been documented by the selling dealer prior to retail delivery.
4. Defects or damage to the motorcycle caused by alterations outside of Harley-Davidson factory specifications.

Important: Read Carefully

Other Limitations

This warranty does not cover:

1. Parts and labor for normal maintenance as recommended in the Owner's Manual, or the replacement of parts due to normal wear and tear including such items as the following: tires, lubrication, oil and filter change, fuel system cleaning, battery maintenance, engine tune-up, spark plugs, brake, clutch and chain/belt adjustment (including chain replacement).
2. Cosmetic concerns that arise as a result of owner abuse, lack of proper maintenance or environmental conditions (except concerns that result from defects in material or workmanship, which are covered by this warranty for the duration of the warranty period).
1. Our dealers are independently owned and operated and may sell other products. Because of this, HARLEY-DAVIDSON IS NOT RESPONSIBLE FOR THE SAFETY, QUALITY, OR SUITABILITY OF ANY NON-HARLEY-DAVIDSON PART, ACCESSORY OR DESIGN MODIFICATION INCLUDING LABOR WHICH MAY BE SOLD AND/OR INSTALLED BY OUR DEALERS.
2. TO THE FULLEST EXTENT ALLOWED BY LAW, HARLEY-DAVIDSON AND ITS DEALERS SHALL NOT BE LIABLE FOR LOSS OF USE, INCONVENIENCE, LOST TIME, COMMERCIAL LOSS OR OTHER INCIDENTAL OR CONSEQUENTIAL DAMAGES.
3. Some states do not allow the exclusion or limitation of incidental or consequential damages, so the above limitation or exclusion may not apply to you. This warranty gives you specific legal rights, and you may have other rights which vary from state to state.

4. This warranty is a contract between you and the manufacturer. It is separate and apart from any warranty you may receive or purchase from the dealer. The dealer is not authorized to alter, modify, or in any way change the terms and conditions of this warranty.
5. Any warranty work or parts replacement authorized by the manufacturer will not preclude the manufacturer from later relying on any exclusion where applicable.



NOTES



REGULAR SERVICE INTERVALS

Regular lubrication and maintenance will help keep your new Harley-Davidson operating at peak performance. Your Harley-Davidson dealer knows best how to service your motorcycle with factory approved methods and equipment assuring you of thorough and competent workmanship.

NOTE

- Refer to Table 37. Regular maintenance interval operations are required to keep your new motorcycle warranty in force. The use of other than Harley-Davidson approved parts and service procedures may void the warranty. Any alterations to the emission system components, such as the carburetor and exhaust system, may be in violation of Federal and State laws.
- Refer to Table 38. When servicing your motorcycle, bring this owner's manual to the dealership and complete information needed in the blank columns listed.

⚠ WARNING

Perform the service and maintenance operations as indicated in the regular service interval table. Lack of regular maintenance at the recommended intervals can affect the safe operation of your motorcycle, which could result in death or serious injury. (00010a)

⚠ WARNING

If you operate your motorcycle under adverse conditions (severe cold, extreme heat, very dusty environment, very bad roads, through standing water, etc.), you should perform the regular maintenance intervals more frequently to ensure the safe operation of your motorcycle. Failure to maintain your motorcycle could result in death or serious injury. (00094a)

Table 37. Regular Service Intervals: 2005 Sportster Models

ITEM SERVICED	PROCEDURE	1600 km 1000 mi.	8000 km 5000 mi.	16,000 km 10,000 mi.	24,000 km 15,000 mi.	32,000 km 20,000 mi.	40,000 km 25,000 mi.	NOTES
Engine oil and filter	Replace	X	X	X	X	X	X	
Oil lines and brake system	Inspect for leaks	X	X	X	X	X	X	1
Air cleaner	Inspect, service as required	X	X	X	X	X	X	
Tires	Check pressure, inspect tread	X	X	X	X	X	X	
Wheel spokes	Check tightness	X	X	X	X	X	X	1, 4
Transmission lubricant	Replace	X	X	X	X	X	X	

Table 37. Regular Service Intervals: 2005 Sportster Models

ITEM SERVICED	PROCEDURE	1600 km 1000 mi.	8000 km 5000 mi.	16,000 km 10,000 mi.	24,000 km 15,000 mi.	32,000 km 20,000 mi.	40,000 km 25,000 mi.	NOTES
Clutch	Check adjustment	X	X	X	X	X	X	1
Primary chain	Check adjustment	X	X	X	X	X	X	
Rear belt and sprockets	Inspect, adjust belt	X	X	X	X	X	X	1
Throttle, brake, enrichener and clutch controls	Check, adjust and lubricate	X	X	X	X	X	X	1
Jiffy stand	Inspect and lubricate	X		X		X		1
Fuel valve, lines and fittings	Inspect for leaks	X	X	X	X	X	X	1
Fuel tank filter screen	Clean						X	1
Brake fluid	Check levels and condition	X	X	X	X	X	X	
Brake pads and discs	Inspect for wear	X	X	X	X	X	X	
Front brake lever pin	Inspect		X	X	X	X		1, 2
	Lubricate						X	1, 2
Brake caliper pins	Inspect		X	X	X	X		1, 2
	Lubricate						X	1, 2
Brake caliper boots and bushings	Inspect		X	X	X	X		1, 2
	Replace						X	1, 2
Rear master cylinder outer boot	Inspect		X	X	X	X	X	1, 2
Brake components	Replace brake rubber components in master cylinders and calipers						X	1, 2
	Lubricate master cylinder pistons						X	1, 2
Spark plugs	Inspect	X	X		X		X	
	Replace			X		X		
Electrical equipment and switches	Check operation	X	X	X	X	X	X	
Engine idle speed	Check adjustment	X	X	X	X	X	X	1
Front fork oil	Replace					X		1
Steering head bearings	Adjust	X		X		X		1
	Lubricate			X		X		1
Rear fork bearings			Replace every 48,000 km (30,000 mi.)					1
Shock absorbers	Inspect	X	X	X	X	X	X	1
Critical fasteners	Check tightness	X		X		X		1

Table 37. Regular Service Intervals: 2005 Sportster Models

ITEM SERVICED	PROCEDURE	1600 km 1000 mi.	8000 km 5000 mi.	16,000 km 10,000 mi.	24,000 km 15,000 mi.	32,000 km 20,000 mi.	40,000 km 25,000 mi.	NOTES
Engine mounts and stabilizer links	Inspect			X		X		1
Battery	Check battery and clean connections							3
Road test	Verify component and system functions	X	X	X	X	X	X	
NOTES:	1. Should be performed by an authorized Harley-Davidson dealer, unless you have the proper tools, service data and are mechanically qualified. 2. Replace every four (4) years. 3. Perform annually. 4. Not all vehicles are equipped with spoke wheels. Consult appropriate topic in service manual.							

Table 38. Owner's Maintenance Records

SERVICE MILE INTERVAL	DATE	DEALER NUMBER	TECHNICIAN NAME	TECHNICIAN SIGNATURE
1000 mi. (1600 km)				
5000 mi. (8000 km)				
10,000 mi. (16,000 km)				
15,000 mi. (24,000 km)				
20,000 mi. (32,000 km)				
25,000 mi. (40,000 km)				
30,000 mi. (48,000 km)				
35,000 mi. (56,000 km)				
40,000 mi. (64,000 km)				
45,000 mi. (72,000 km)				
50,000 mi. (80,000 km)				

SERVICE LITERATURE

Refer to Table 39. Visit a Harley-Davidson dealer or www.harley-davidson.com to purchase a service or parts manual

for your motorcycle. Factory authorized manuals are the most complete and detailed source of information outside of your Harley-Davidson dealer.

Table 39. Service Literature: 2005 Sportster Models

DOCUMENT	LANGUAGE	PART NUMBER
Service Manual	English	99484-05A
Electrical Diagnostics Manual	English	99495-05
Service and Electrical Diagnostics Manual	French	99484-05FA
Service and Electrical Diagnostics Manual	German	99484-05GA
Service and Electrical Diagnostics Manual	Spanish	99484-05SA
Service and Electrical Diagnostics Manual	Italian	99484-05IA
Parts Catalog	English	99451-05A



Index

A

Accessories and Cargo Guidelines.....	12
Accessory and Cargo Guidelines.....	12
Address Change.....	148
Air Cleaner Filter.....	113
Alternator/Voltage Regulator.....	120

B

Battery.....	121,127,129
Brakes.....	51,107,146
Break-in.....	89
Break-in Maintenance.....	89
Break-in Riding Rules.....	80
Bulb Chart.....	31

C

Carburetor.....	112,145
Carrying Capacity.....	57
Catalytic Converters.....	37
Charging the Battery.....	121
Chassis Lubrication.....	104
Checking Oil Level.....	90

Cleaning.....	139,140,140,141
Clutch.....	41,106
Controls.....	41,51
Customer service.....	2

D

Dealer Locator.....	148
Dealer Locator Phone Number.....	148

E

Electrical Protection.....	132
Electrical System.....	145
Emergency Flashers.....	45
Engine.....	84,143
Engine Oil.....	45,89,97
Enrichener.....	49
Extended Service Plan Contract.....	148

F

Factory Replacement Parts.....	147
Fork Lock.....	55

Index

Four-Way Flashers.....	45
Front Fork Bearings.....	106
Front Fork Oil.....	105
Fuel.....	36,37,54,112
Fuel and Oil.....	36
Fuel Strainer.....	105
Fuses.....	132

G

Gasoline.....	36,37
Gasoline Blends.....	36
GAWR.....	5,12,31
GAWR/GVWR.....	12
Gross Axle Weight Ratings.....	31
Gross Vehicle Weight Rating.....	31
GVWR.....	5,12,31

H

Hand Controls.....	41
Hazard Warning 4-Way Flasher.....	45
Hazard Warning Four-Way Flasher.....	45

Headlamp.....	45,114
Headlamp Alignment.....	117
Horn.....	41
Hydraulic Lifters.....	106

I

Ignition System.....	39,112
Importing a Motorcycle.....	148
Indicator Lamps.....	45
Instruments.....	45,46

J

Jiffy Stand.....	51
Jump-Starting Battery.....	129

K

Key Switch.....	39
-----------------	----

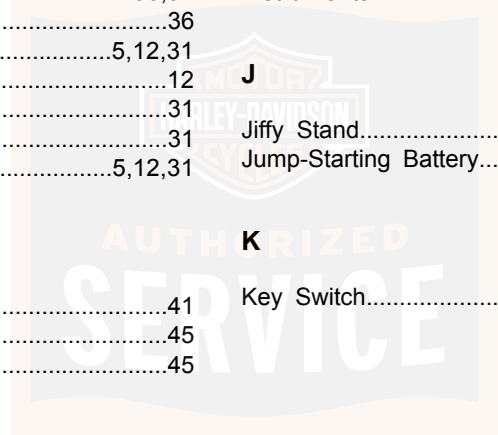

Index

L

Leather.....	139
Leather and Vinyl Care.....	139
Leather Care.....	139
Limited Warranty.....	149
Load.....	57
Lubrication.....	104
Luggage.....	12

M

Maintenance.....	89,89,89,101,104, 105, 105, 106, 106, 106, 107, 111, 112, 113, 120, 121, 147
Manual.....	1
Maxi-Fuse.....	132
Maximum Added Weight Allowed.....	57
Mirror Adjustment.....	52
Mirrors.....	52
Motorcycle Cleaning Products.....	139
Motorcycle Storage.....	136

O

Octane Rating.....	37
--------------------	----

Oil.....	89
Oil and Oil Filter.....	93
Oil Applications.....	105
Operation.....	51,81,84
Owner Transfer Notification Form.....	148

P

Pre-Riding Checklist.....	81
Preload Adjustment.....	57
Primary Chain.....	101
Primary Chain Adjustment.....	101
Primary Chain Free Play.....	101

R

Rear Drive Belt.....	103
Rear Fork Pivot Shaft.....	107
Rules of the Road.....	11

S

Safe Operating Rules.....	5
Safety.....	12,89

Index

Safety Defintions.....	1	Transmission.....	145
Seat.....	135	Transmission Lubrication.....	97
Security System.....	45,61,61,61,61, 62, 65, 65, 66, 67, 72, 73, 74, 75, 76, 77, 77	Troubleshooting.....	45,143,145,145,146
Service Intervals.....	153	Turn Signal Bulbs (Bullet Style).....	119
Service Literature.....	156	Turn Signal Switches.....	44
Shifting Gears.....	84	Turn Signals.....	41,44,45,45
Shock Absorber.....	57		
Shock Absorbers.....	57,111	V	
Sidestand.....	51	V.I.N.....	28
Smart Security System.....	61	Voltage Regulator/Alternator.....	120
Spark Plug Replacement.....	112		
Spark Plugs.....	112	W	
Specifications.....	37,89	Warranty.....	147,148,149
Starting the Engine.....	82	Warranty Repair Work.....	148
Stopping the Engine.....	84	Wheel Care.....	140
Storage.....	136	Wheels.....	140
Suspension.....	57	Whitewall Tires.....	140
Switches.....	39	Windshield.....	141
		Windshield Cleaning.....	141
T		Winter Lubrication.....	97
Tire Replacement.....	110		
Tires.....	35,108,110		