



# INSTRUCTIONS

94100006

2020-03-05



## BOOM! AUDIO 30K BLUETOOTH HEADSET

### GENERAL

#### Kit Number

76000838, 76000840

#### Models

For model fitment information, see the Parts and Accessories (P&A) Retail Catalog or the Parts and Accessories section of [www.harley-davidson.com](http://www.harley-davidson.com) (English only).



The internal lithium battery is **NOT** replaceable. Consumers are responsible for recycling used electronics. Dispose in accordance with methods that meet or exceed all state and federal environmental laws.

Visit <https://serviceinfo.harley-davidson.com> for the latest instruction sheet.

### INSTALLATION REQUIREMENTS

#### NOTE

The headset will function differently based on whether it is:

- Paired to the Wireless Headset Interface Module (WHIM).
- Paired to the **phone**.

Headset will **ONLY** pair to Harley-Davidson Boom!™ Box GTS or 6.5GT radio via a WHIM.

Headset **WILL NOT** pair directly to a Harley-Davidson radio via the radio's Bluetooth menu.

If the vehicle has a WHIM installed, use the following instructions.

#### Pair with Boom! Box GTS or 6.5 GT Radio

The following items are available at your Harley-Davidson dealership.

- **2014 and later Touring and Trike models:** Separate purchase of WHIM (Part No. 76000768) is required.
- **2014-2018 Touring and Trike models:** Boom! Box 6.5 GT equipped vehicles require separate purchase of WHIM Harness (Part No. 69201726).
- **2014 and later FLHTCU(L), FLHTK(L,SE) and FLHX(S,SE) models:** Satellite radio requires relocation of antenna. New bracket is included in kit.
- Software flash by DIGITAL TECHNICIAN II (PART NUMBER: HD-48650). Performed by Harley-Davidson dealer.
- Radio software updated to most recent version. See [www.H-D.com/infotainment-support](http://www.H-D.com/infotainment-support)

### WIRELESS HEADSET

Read the Quick Start Guide for additional information pertaining to the wireless headset operation. Also see [www.H-D.com/infotainment-support](http://www.H-D.com/infotainment-support) for the latest version of User's Guide and related information to Boom! Audio Bluetooth products or visit your local Harley-Davidson dealership.

#### Getting Started

Charge the wireless headset. The Light Emitting Diode (LED) turns red while the headset is charging and turns blue when it is fully charged. It takes about 1.5 hours to charged completely.

#### Headset Software Version

The BOOM! AUDIO 30K BLUETOOTH HEADSET supports firmware upgrade function. Visit [www.H-D.com/infotainment-support](http://www.H-D.com/infotainment-support) to check for the latest software downloads.

#### Headset and Clamp Unit

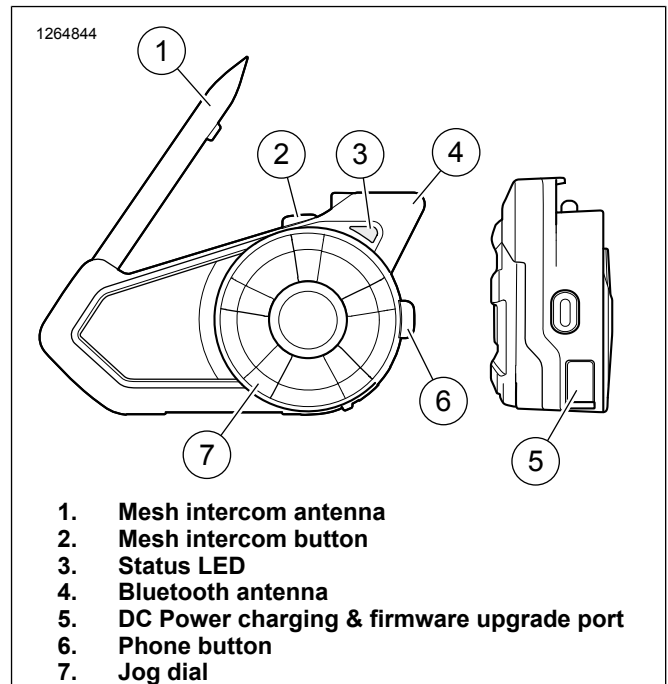

Figure 1. Boom! Audio 30K Headset Layout

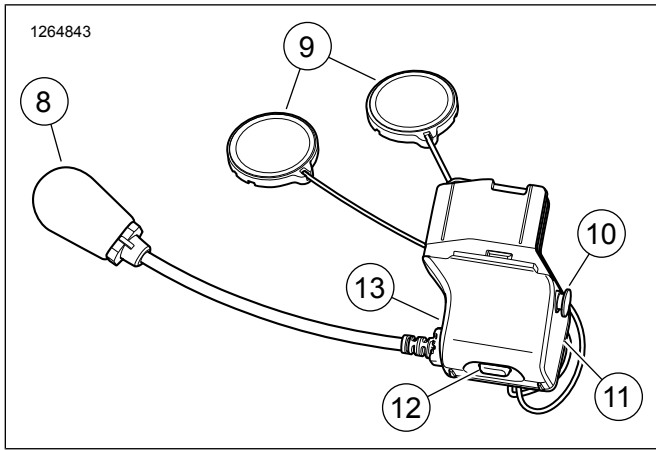

Figure 2. Boom! Audio 30K Universal Clamp

Table 1. 30K Headset Button Function

Item	Description	Function
1	Mesh intercom antenna	Pull mesh intercom antenna outwards slightly to unfold it.
2	Mesh intercom button	Mesh intercom On/Off Create mesh intercom Join existing mesh Accept participant Reject participant
3	Status LED	Red and blue visual confirmation
4	Bluetooth antenna	A PCB trace antenna which radiates and receives the electromagnetic waves that wirelessly carry information to and from other bluetooth devices
5	DC Power charging & firmware upgrade port	Plugged into a computer's Universal Serial Bus (USB) port USB-equipped AC adapter via a wall-outlet charger
6	Phone button	Answer/End phone call FM Tuner On/Off Speed dial
7	Jog dial	Increase/Decrease volume Play/Pause music Track Forward/Back Scan radio stations Enter intercom pairing mode Enter voice configuration settings
8	Static boom microphone	Located close to mouth when helmet is worn. Fin side of microphone is facing outward.
9	Speaker	Speaker with short wire is for left ear and speaker with long wire is for right ear.
10	Quick release button	To remove main unit from clamp unit.
11	MP3 Port	Connect MP3 device to headset.
12	Ambient mode button	Ambient mode Group intercom Voice command
13	Earbud port	Connect earbuds to clamp.

## Pair Wireless Headset to WHIM

### NOTE

**Wireless Headset** selection **MUST** be used to pair any wireless headset. **DO NOT** use **Bluetooth Setup** for any wireless headset. Use **Bluetooth Setup** for pairing Bluetooth equipped phones or media devices.

- Turn on wireless headset.
  - Powering On:** Press Phone Button and Jog Dial at the same time while hearing a voice prompt, **Preparing Headset** followed by ascending beeps and another voice prompt **Hello**.
- Navigate:** Home > Setup.

### 3. NOTE

*Boom! Box GTS radio is shown. Radio screen for 6.5 GT will vary but instruction content is the same.*

See Figure 3. **Scroll and Select:** Wireless Headset Setup.

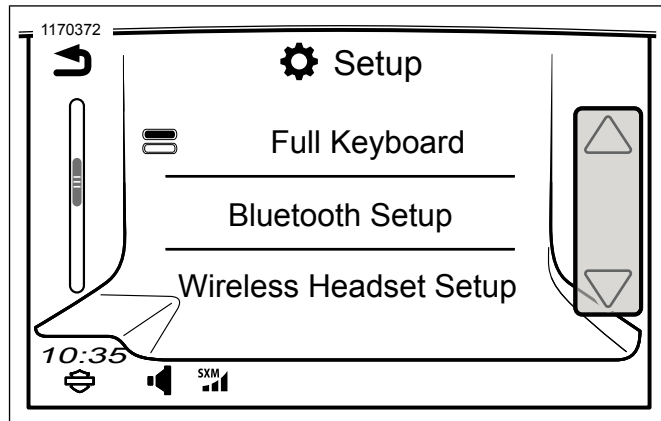

Figure 3. Select Wireless Headset

### 4. NOTE

*It does not matter if headset or WHIM (vehicle) is placed into pairing mode first. If **Wireless Headset Setup** does not appear, confirm that a WHIM has been installed and all software has been updated.*

See Figure 4. **Select:** Pair Rider.

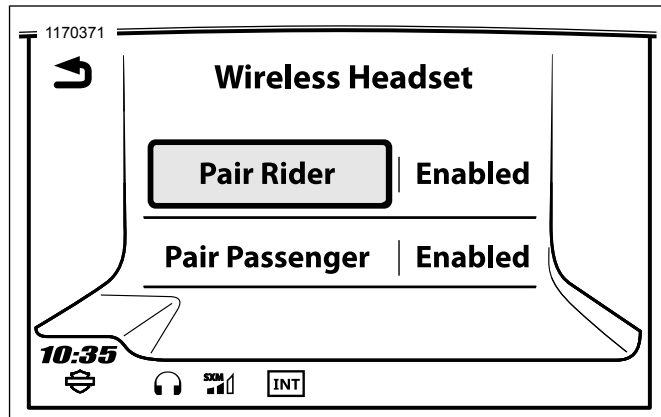

Figure 4. Pair Rider Headset

5. Place headset into pairing mode.
  - a. **Press:** Phone Button for 5 seconds or until headset enters Phone Pairing.

**NOTE**

Headset will audible **Phone Pairing**.

6. 

**NOTE**

Harley-Davidson headsets will show up as Boom Audio followed by product description and version. See owner's manual of non-Harley-Davidson products for communications display.

**Select:** Boom Audio 30K.

7. See Figure 5. When properly paired the screen will display the following:
  - a. Model with software version (version will vary)
  - b. Bluetooth address (address will vary)
  - c. Status of connectivity

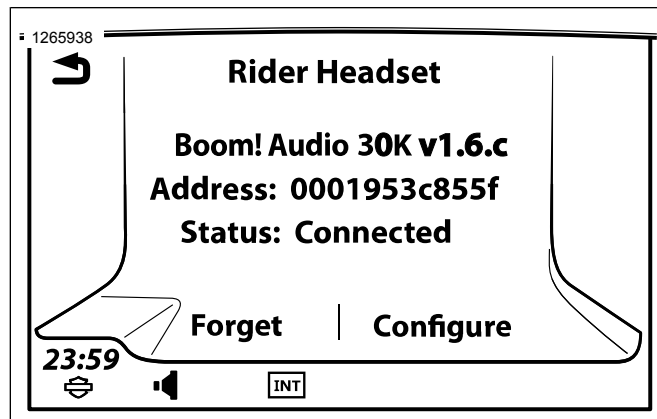

**Figure 5. Headset Status**

8. Repeat procedure for passenger headset.

## Headset Configurations

**NOTE**

The wireless headset must be turned on and paired with the system for the following configurations to appear on the touchscreen.

The 30K has 14 configuration settings that can be accessed through the Boom! Box Infotainment system.

**Navigate:** Home > Setup > Wireless Headset > Manage Rider or Passenger Headset > Config.

**Smart Vol. Control:** Automatically adjusts speaker volume based on the amount of environmental noise captured by the microphone. When it is disabled, volume is controlled manually. You can enable it by setting the sensitivity to low, medium, or high. The headset will respond to smaller environmental noises as the sensitivity level becomes higher. This factory setting is disabled.

**SideTone:** Sidetone is the sound of your own voice as picked up by your headset's microphone and reproduced in your own

ear, by your own speaker. It helps you to naturally speak at the correct level according to varying helmet noise conditions. If this feature is enabled, you can hear what you are speaking during an intercom conversation or a phone call. This factory setting is disabled.

**Voice Prompt:** You can disable voice prompts, but the following voice prompts are always on:

- Voice prompts for configuration setting menu
- Voice prompts for battery level Indicator
- Voice prompts for factory reset
- Voice prompts for speed dial
- Voice prompts for FM radio functions

**Adv. Noise Control:** When Advanced Noise Control is enabled, the background noise is reduced during an intercom conversation. When it is disabled, the background noise is mixed with your voice during intercom. This factory setting is enabled.

**VOX Phone:** If this feature is enabled, you can answer incoming calls by simply saying a word loudly enough, unless you are connected to intercom. For example, when you hear a series of beeps for an incoming call, you can answer the phone by saying **Hello** or any other word loudly. However, the VOX Phone feature does not work if you are connected to the intercom. This feature is enabled from the factory but can be disabled through the configuration menu, Device Manager, or the Sena Smartphone App. If this mode is disabled, you have to tap the Jog Dial or the Phone Button to answer an incoming call.

**HD Intercom:** HD Intercom enhances the two-way intercom audio from normal quality to HD quality. HD Intercom will become temporarily disabled when you enter into a multi-way intercom. If this feature is disabled, the two-way intercom audio will change to normal quality. This factory setting is enabled.

**Intercom-Audio Sensitivity (Intercom-Audio Overlay Sensitivity):** The music, FM radio and GPS volume will be lowered to play in the background if you talk over the intercom while the overlaid audio is playing. Level 1 is the lowest sensitivity and you will have to speak very loud. Level 5 is the most sensitive and will trigger with very little sound. Pending on riding conditions this may need to be adjusted due to ambient noise. The factory setting is 3.

**FM Station Guide:** When enabled, FM station frequencies are given by voice prompts as you select preset stations. When disabled, the voice prompts on FM station frequencies will not be given as you select preset stations. This factory setting is enabled.

**Radio Data System (RDS) Alternative Frequency (AF):** When radio station signals get too weak for a good reception, with RDS AF enabled, the radio receiver re-tunes to a station with better reception. If RDS AF is disabled, you'll have to find stronger stations manually. Factory Default is disabled.

**VOX Intercom:** Voice Activated Intercom. If this feature is enabled, you can initiate an intercom conversation with the last connected intercom friend by voice. When you want to start intercom, say a word such as **Hello** loudly or blow air into the microphone. If you start an intercom conversation by voice, the intercom terminates automatically when you and your intercom friend remain silent for 20 seconds. However, if you manually start an intercom conversation by tapping the Jog Dial, you have to terminate the intercom conversation manually. This factory setting is disabled.

**Audio Overlay Vol. (Audio Overlay Volume Management):**

The music, FM radio and Global Positioning System (GPS) overlaid audio reduces in volume whenever there is an ongoing intercom conversation. If Audio Overlay Volume Management is enabled, the volume level of the overlaid audio will not be reduced during an intercom conversation. This factory setting is disabled.

**Intercom VOX Sensitivity:** The sensitivity can be adjusted depending on your riding environment. Level 5 is the highest sensitivity setting and 1 is the lowest. This factory setting is 3.

**Guest Mode:** Guest Mode allows a guest to listen to a closed Mesh conversation. The creator of the Mesh needs to enable Guest Mode before creating the Mesh to allow guests. Guest Mode can be enabled when the guest is in Public Mode and the Mesh Network connection information has been removed. The guest needs to be within range of the Mesh to listen to the closed Mesh conversation. This factory setting is disabled.

**Voice Command:** The voice command of the headset allows you to operate certain operations by simply using your voice. You can control the headset completely handsfree using the voice recognition. The voice command function works only with English commands. This factory setting is enabled.

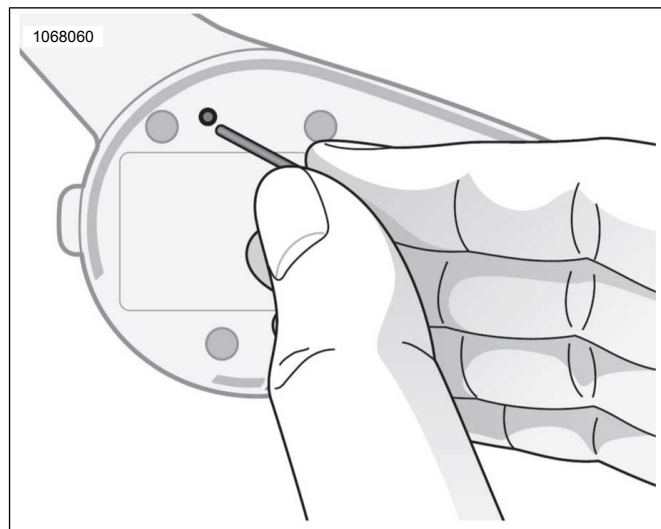

Figure 6. Fault Reset

## Unpair Wireless Headset

1. **Navigate:** Home > Setup > Wireless Headset.
2. **Select:** Manage Rider or Passenger headset.
3. **Select:** Forget. This will delete wireless headset from Boom! System.

## Reset Factory Headset Settings

### NOTE

*When performing this procedure, the link between the Boom! Infotainment system and headset will be broken. The wireless headsets must be paired again for system communications to operate properly.*

1. To restore the Boom! Audio 30K to factory default settings, press and hold the Phone Button for 12 seconds until the LED shows solid red. You will hear a voice prompt saying **Factory reset**.
2. Within 5 seconds, press the Jog Dial to confirm reset. The headset will be restored to factory settings and switched off automatically. You will hear a voice prompt saying **Headset reset, good-bye**.
3. If you press the Phone Button or do not press the Jog Dial within 5 seconds, the reset attempt is canceled and the headset returns to stand-by mode. A voice prompt will say **Canceled**.

## Fault Reset

See Figure 6. When the Boom! Audio 30K is not working properly or is in faulty status for any reason, you may reset by pushing the pin-hole reset button at the back of the headset main unit. Insert a paper clip into the reset pin-hole and press the reset button for a second with light pressure. The Boom! Audio 30K will be switched off and then turn the system back on and try again. However, this will not restore the headset to factory default settings.