



INSTRUCTIONS

94100017

2021-02-02



HEATED AND COOLED SEAT KIT

GENERAL

Kit Number

52000462, 52000462DEMO, 52000463, 52000463DEMO, 52100063

Models

For model fitment information, see the P&A Retail Catalog or the Parts and Accessories section of www.harley-davidson.com (English only).

Installation Requirements

If another accessory is already using the accessory circuit connector, see Figure 4, then a "Y" adapter harness is required.

2014-2016 models: If another accessory is already using the accessory circuit connector, use a Switch Circuit Adapter Harness (70264-94A) purchased separately, as a "Y" adapter.

2017-later models: If another accessory is already using the accessory circuit connector, use a Switch Circuit Adapter Harness (69201706) purchased separately, as a "Y" adapter.

Trike models: Separate purchase of adapter bracket kit (52100063).

2014-2016 models: Installation of Kit 69200722 is required to locate the accessory circuit connector under the seat.

2017-Later models: Installation of Kit 69201599A is required to locate the accessory circuit connector under the seat.

Heated and cooled seat is compatible with rider backrest mounting kits 52589-09A and 52300642. Seat is not compatible with rider backrest mounting kits 52596-09A and 54099-10.

Electrical Overload

NOTICE

It is possible to overload the vehicle's charging system by adding too many electrical accessories. If the combined electrical accessories operating at any one time consume more electrical current than the vehicle's charging system can produce, the electrical consumption can discharge the battery and cause damage to the vehicle's electrical system. (00211d)

⚠ WARNING

When installing any electrical accessory, be certain not to exceed the maximum amperage rating of the fuse or circuit breaker protecting the affected circuit being modified. Exceeding the maximum amperage can lead to electrical failures, which could result in death or serious injury. (00310a)

Seat requires up to **4 Amps** of current from the electrical system.

Kit Contents

See Figure 11 and Table 2 for kit contents.

REMOVE

1. Remove grab strap. See service manual.
2. Remove seat. See service manual.
3. Remove saddlebag. See service manual.

Seat Removal

1. **Tour-Pak® models:** Open Tour-Pak lid. Lift front pad to access seat mounting.
2. See Figure 11. Remove phillips-head screw with lockwasher (A) from rear of currently installed seat. Pull seat rearward to remove seat. Retain screw.
3. **Fender Strips:** If equipped, remove fender trim strips:
 - a. Cover tip of a regular screwdriver with a piece of tape to protect chrome and painted surfaces.
 - b. See Figure 1. Insert tip of screwdriver between chrome bezel and rubber trim strip.
 - c. Pry up the bezel. Pull it up and away from rubber trim strip.
 - d. Starting at either end, peel rubber trim strip away from fender.
 - e. Clean with a mixture of 50 percent isopropyl alcohol and 50 percent distilled water.

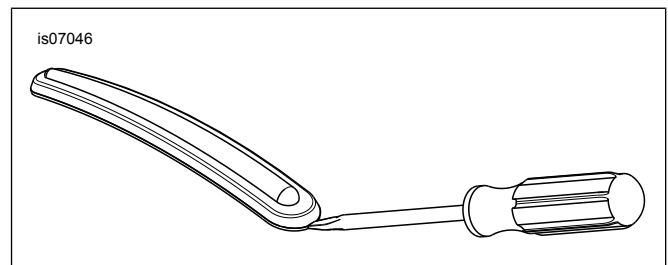

Figure 1. Remove Fender Trim Strip

INSTALL

Bumper Replacement

NOTE

Touring vehicles that have saddlebag guards installed and ALL Trike vehicles do not require installation of spacers (10300256). Discard spacers.

1. Figure 2 Remove Bumpers.
 - a. Remove bolts (1). Retain.
 - b. Remove bumpers (2). Discard.
 - c. Install spacers (3).
 - d. Install Original Equipment (OE) bolts (1). Tighten. Torque: 43.4–49 N·m (32–36 ft-lbs)

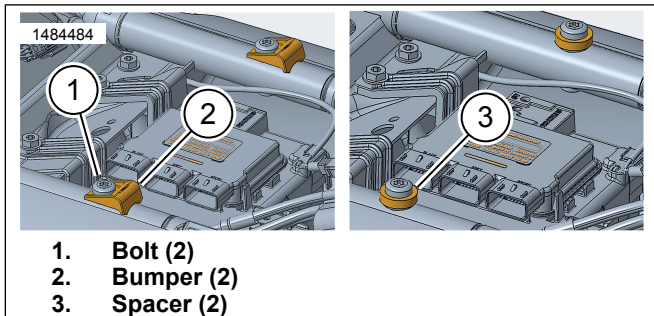

Figure 2. Bumper Removal / Spacer Install

New Seat and Grab Strap Installation

NOTE

Figure 3 2014-later Trike models: Require separate purchase of adapter bracket kit (52100063).

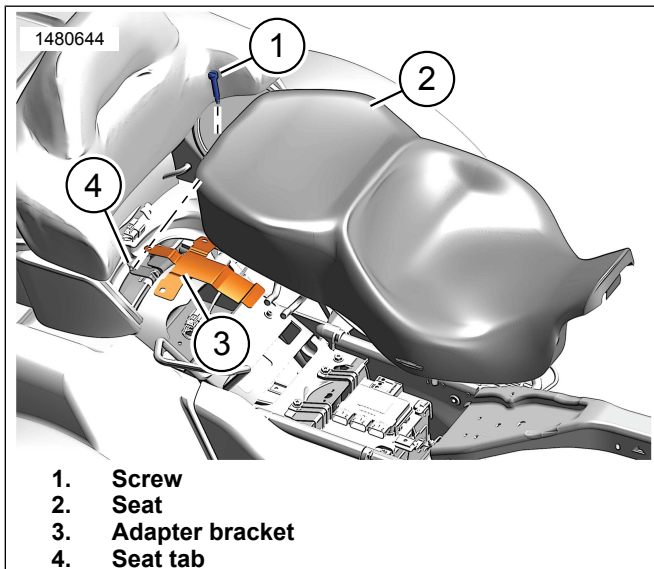

Figure 3. Trike Seat Install

1. Install **new** grab strap. See service manual.

⚠ WARNING

To prevent accidental vehicle start-up, which could cause death or serious injury, disconnect negative (-) battery cable before proceeding. (00048a)

2. Follow the instructions in the owner's manual to remove the negative battery cable from the battery.
3. Figure 4 Identify and remove plug from accessory circuit connector (6).

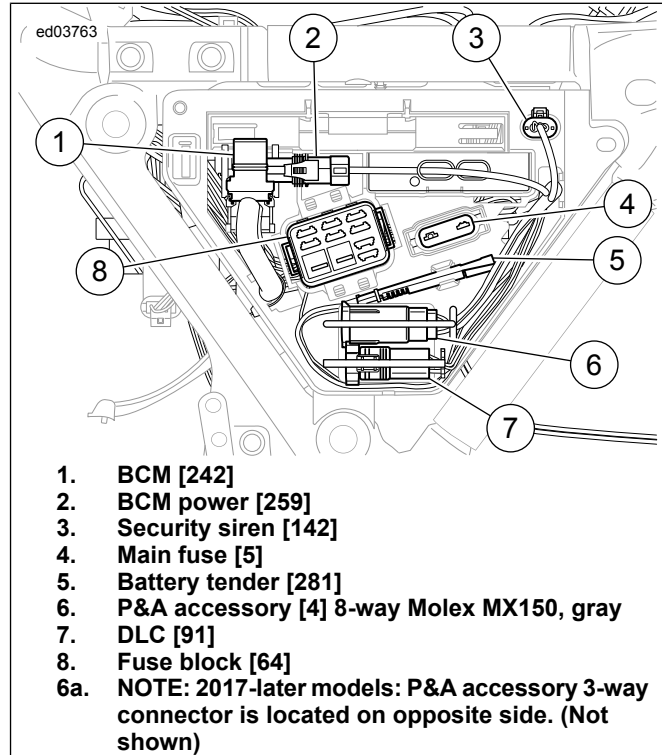
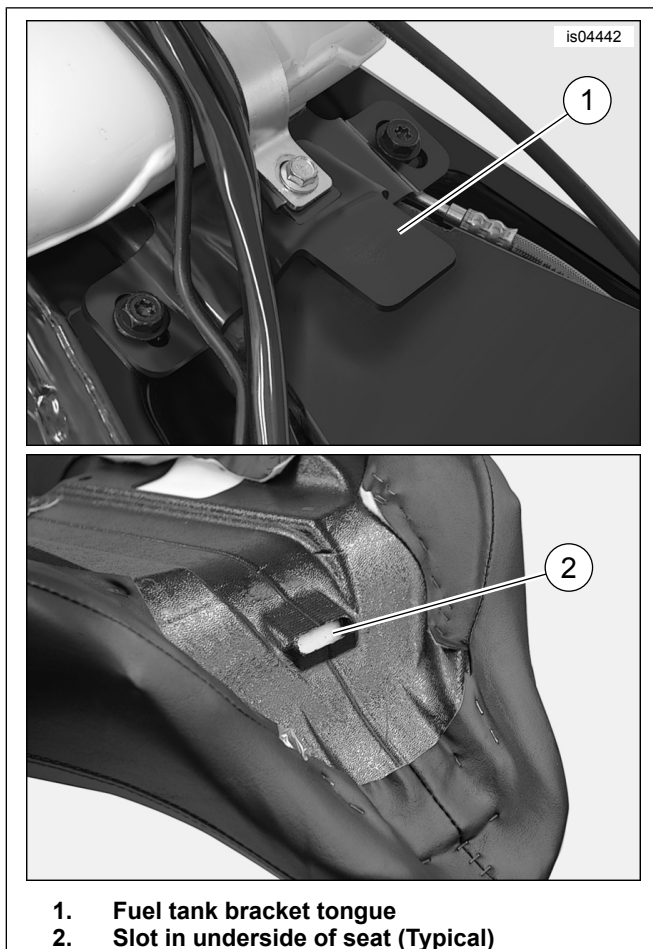

Figure 4. 2014-2016: Left Side Cover

4. Locate heated and cooled seat connector on underside of **new** seat.
5. Connect heated and cooled seat connector to accessory circuit connector (6).
6. See owner's manual. Connect negative (-) battery cable.
7. Guide wiring into space beneath seat so that wiring will not be pinched when seat is installed.
8. Verify harness fuse holder cap is fully seated and secured to clear seat base.
9. See Figure 5. If already installed, slide rear of seat through grab strap, from the front, until slot (2) on front underside of seat is behind seat mounting tongue (1) on fuel tank rear bracket.



1. Fuel tank bracket tongue
2. Slot in underside of seat (Typical)

Figure 5. Seat Front Mounting (Typical)

10. Press seat down onto frame backbone.
11. Slide seat toward front of vehicle until fuel tank bracket tongue fully engages into the slot under seat.
12. Secure seat onto rear fender using a phillips-head screw (with lockwasher) removed in Seat Removal. Tighten.
Torque: 5.4–8.1 N·m (4–6 ft-lbs)
13. Install seat. After installing seat, pull up on the seat to verify that it is secure. See service manual.
14. Install grab strap. See service manual.
15. If removed, install saddlebags to vehicle. See service manual. Secure with OE bail head studs and flat washers.

NOTE

The molded rubber insert at the bottom of the saddlebags must fit snugly on the lower saddlebag support rails.

16. Tighten forward saddlebag mounting bolts. Tighten.
Torque: 7–11 N·m (62.0–97.4 in-lbs)

OPERATION

NOTE

- **Seat operation while vehicle's engine is turned off or running below normal operating speed can quickly discharge vehicle battery. This could lead to a subsequent failure to start and could damage the electrical system.**
- For some vehicles, accessory switch is a rocker switch found on inner fairing switch panel. With ignition/key switch at IGNITION or ACCY, close circuit to heated and cooled seat by flipping accessory switch from OFF to ON.
- See owner's manual for operation of vehicle's accessory circuit.
- If accessory switch is left ON and a seat rotary switch is left in a non-off position when vehicle is turned off, seat will begin heating or cooling when ignition/key switch is turned to IGNITION or ACCY position.
- Fans are only in operation when seat is in cooling mode and rider, passenger or both positions are turned to a power level setting above OFF.
- Both rider and passenger fans will simultaneously turn on and off.
- It is not normal for only one fan to operate at a time.
- Fan speed will not vary with power level setting.
- Strength of cooling is controlled by the current through heating/cooling element rather than fan speed.
- Seat may take 2-5 minutes to achieve optimal heating effect and 10-20 minutes to achieve optimal cooling effect.
- Seat does not blow air on the rider or passenger.
- When cleaning, take care not to pull boot off rocker switch. Do not attempt to remove rotary knobs or boot on rocker switch. These items are not intended to be serviceable.

Seat Control Switches

1. Figure 6 Rotary switches (1,3):
 - a. Controls the individual level setting of rider and passenger zones.
 - b. Level controls are independent.
 - c. Detents on switches allow operator to quickly return to preferred setting.
 - d. Rider control (1) is located closest to rider's seating position.
 - e. Passenger control (3) is located closest to passenger's seating position.
 - f. Lowest setting, first detent, turns seating position OFF regardless of setting on the other control or heat/cool switch (2).
 - g. Additional four detents increase strength of the heating or cooling function set.
2. Figure 6 Heat/cool switch (2):
 - a. Press "H" for heating.

b. Press "C" for cooling.

3. Fans:

- a. Both remain OFF whenever heating is pressed.
- b. Both remain ON whenever either rider or passenger is set to a level other than OFF and "C" is pressed.
- c. Fans are always both OFF or both ON.
- d. Fans exhaust the waste heat from underside of heating/cooling element when in cooling mode. Path of air is not through the seating surface.
- e. Fans do not blow air on rider or passenger.
- f. Seat Remote Input / Output - Electronic Seat Controller (RIO-ESC) operates fans at the same speed regardless of level setting.
- g. Seat draws large currents which changes fan speed slightly.
- h. Slight fan speed changes may be audible under low ambient noise conditions. This is normal.

4. Performance Characteristics:

- a. Optimal heating takes 2-5 minutes.
- b. RIO-ESC drives heat to a set temperature based on control switch level setting.
- c. Maximum temperatures may not be achievable in extreme cold conditions due to a maximum power limitation within seat.
- d. Optimal cooling conditions take between 10 and 20 minutes.
- e. RIO-ESC drives cooling as a percentage of full power based on control switch level setting to maximize benefit to rider and passenger under varying ambient temperature.
- f. Maximum performance depends on a healthy charging system since power is limited by system voltage.
- g. Performance will be degraded or shut down at unusually low system voltage. Such as with key turned to accessory mode and battery not at full charge.
- h. Heat is transferred to and removed from occupant through conduction. Choice of clothing will affect performance.
- i. Heating/cooling elements are only located under a portion of seating surface where buttocks make contact. Thigh areas will not be heated or cooled.

5. Diagnostics:

- a. RIO-ESC contains three LED's exposed on backside: these are most easily visible by unclipping RIO-ESC from seat base. Cable strap on RIO-ESC harness must be replaced if cut.
- b. Event codes are displayed in sequential order and continue to sequence so long as power remains applied to the seat. To verify all event codes are identified, monitor LED's until the same event code is reported a second time.
- c. All event codes will clear with a power cycle.
- d. If the cause of event code is still present after cycling power, the RIO-ESC will set the appropriate code again.
- e. Troubleshooting may require rider to physically detach seat from vehicle frame and gain access to RIO-ESC without removing power.
- f. Seat automatically attempts to clear event when cause of event is corrected. Process takes between 5-30 seconds.
- g. Codes remain displayed until power cycling even if seat is able to self-recover and operate normally.
- h. See Table 1 for event code definition.

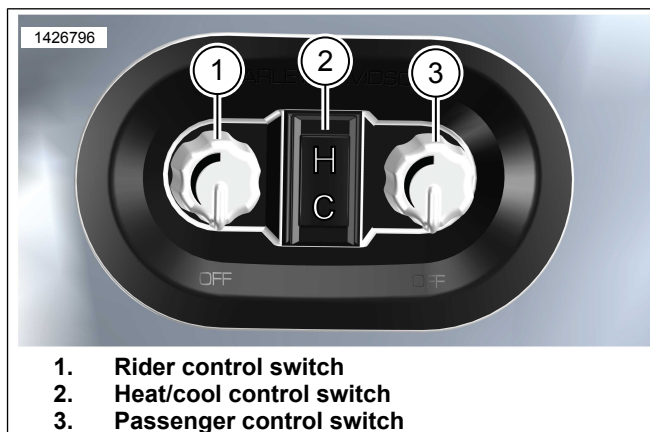

Figure 6. Seat Heating/Cooling Control Switches

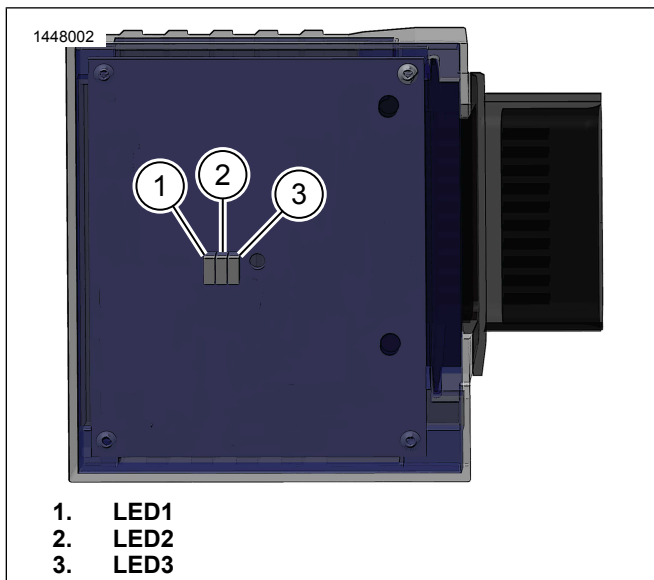

Figure 7. RIO LEDs

Table 1. Event Codes

LED	Flashes	Code	Detection	Possible Causes	Troubleshooting Actions
1	1	Internal Controller Switch A	Monitored internal chip fault signal	<ul style="list-style-type: none"> Controller internal damage or misoperation 	<ul style="list-style-type: none"> See dealer
1	2	Internal Controller Switch B	Monitored internal chip fault signal	<ul style="list-style-type: none"> Controller internal damage or misoperation 	<ul style="list-style-type: none"> See dealer
1	3	Internal Controller Switch C	Monitored internal chip fault signal	<ul style="list-style-type: none"> Controller internal damage or misoperation 	<ul style="list-style-type: none"> See dealer
1	4	Internal Controller Switch D	Monitored internal chip fault signal	<ul style="list-style-type: none"> Controller internal damage or misoperation 	<ul style="list-style-type: none"> See dealer
1	5	Over-current A	Measure heating/cooling element current draw	<ul style="list-style-type: none"> Controller internal damage or misoperation Heating/cooling element damage Harness damage 	<ul style="list-style-type: none"> See dealer
1	6	Under-current A	Measure heating/cooling element current draw	<ul style="list-style-type: none"> Plug continuity Heating/cooling pad fuse trip Heating/cooling element damage Harness damage 	<ul style="list-style-type: none"> Verify plug is clean and fully seated Turn seat to OFF and allow both seat sections to return to room temperature for 5 minutes See dealer
1	7	Over-current C	Measure heating/cooling element current draw	<ul style="list-style-type: none"> Controller internal damage or misoperation Heating/cooling element damage Harness damage 	<ul style="list-style-type: none"> See dealer
1	8	Under-current C	Measure heating/cooling element current draw	<ul style="list-style-type: none"> Plug continuity Heating/cooling pad fuse trip Heating/cooling element damage Harness damage 	<ul style="list-style-type: none"> Verify plug is clean and fully seated Turn seat to OFF and allow both seat sections to return to room temperature for 5 minutes See dealer

Table 1. Event Codes

LED	Flashes	Code	Detection	Possible Causes	Troubleshooting Actions
1	9	Over-current D	Measure heating/cooling element current draw	<ul style="list-style-type: none"> • Controller internal damage or misoperation • Heating/cooling element damage • Harness damage 	<ul style="list-style-type: none"> • See dealer
1	10	Under-current D	Measure heating/cooling element current draw	<ul style="list-style-type: none"> • Plug continuity • Heating/cooling pad fuse trip • Heating/cooling element damage • Harness damage 	<ul style="list-style-type: none"> • Verify plug is clean and fully seated • Turn seat to OFF and allow both seat sections to return to room temperature for 5 minutes • See dealer
2	1	Fan 1 Low Speed	Measured fan feedback signal	<ul style="list-style-type: none"> • Physical drag (blockage) on fan blade • Plug continuity • Harness damage 	<ul style="list-style-type: none"> • Clear blockage • Verify plug is clean and fully seated • Replace fan • See dealer
2	2	Fan 2 Low Speed	Measured fan feedback signal	<ul style="list-style-type: none"> • Physical drag (blockage) on fan blade • Plug continuity • Harness damage 	<ul style="list-style-type: none"> • Clear blockage • Verify plug is clean and fully seated • Replace fan • See dealer
2	3	Fan 1 High Speed	Measured fan feedback signal	<ul style="list-style-type: none"> • Airstream restriction • Damaged fan 	<ul style="list-style-type: none"> • Replace fan • See dealer
2	4	Fan 2 High Speed	Measured fan feedback signal	<ul style="list-style-type: none"> • Airstream restriction • Damaged fan 	<ul style="list-style-type: none"> • Replace fan • See dealer
2	5	Fan 1 Stall	Measured fan feedback signal	<ul style="list-style-type: none"> • Complete blockage on fan blade • Plug continuity • Damaged fan • Harness damage 	<ul style="list-style-type: none"> • Clear blockage • Verify plug is clean and fully seated • Replace fan • See dealer
2	6	Fan 2 Stall	Measured fan feedback signal	<ul style="list-style-type: none"> • Complete blockage on fan blade • Plug continuity • Damaged fan • Harness damage 	<ul style="list-style-type: none"> • Clear blockage • Verify plug is clean and fully seated • Replace fan • See dealer
2	7	Fan 1 Over-current	Measured fan current draw	<ul style="list-style-type: none"> • Physical drag (blockage) on fan blade • Damaged fan • Harness damage 	<ul style="list-style-type: none"> • Clear blockage • Replace fan • See dealer
2	8	Fan 1 Under-current	Measured fan current draw	<ul style="list-style-type: none"> • Airstream restriction • Plug continuity • Damaged fan • Harness damage 	<ul style="list-style-type: none"> • Verify plug is clean and fully seated • Replace fan • See dealer
2	9	Fan 2 Over-current	Measured fan current draw	<ul style="list-style-type: none"> • Physical drag (blockage) on fan blade • Damaged fan • Harness damage 	<ul style="list-style-type: none"> • Clear blockage • Replace fan • See dealer

Table 1. Event Codes

LED	Flashes	Code	Detection	Possible Causes	Troubleshooting Actions
2	10	Fan 2 Under-current	Measured fan current draw	<ul style="list-style-type: none"> Airstream restriction Plug continuity Damaged fan Harness damage 	<ul style="list-style-type: none"> Verify plug is clean and fully seated Replace fan See dealer
2	11	Rider Temp High 3	Measured heating/cooling element temperature	<ul style="list-style-type: none"> Heating/cooling element damage Heating/cooling element above operating temperature limit Plug continuity 	<ul style="list-style-type: none"> Allow seat to cool to room temperature Cycle heat/cool rocker control Verify plug is clean and fully seated See dealer
2	12	Passenger Temp High 3	Measured heating/cooling element temperature	<ul style="list-style-type: none"> Heating/cooling element damage Heating/cooling element above operating temperature limit Plug continuity 	<ul style="list-style-type: none"> Allow seat to cool to room temperature Cycle heat/cool rocker control Verify plug is clean and fully seated See dealer
3	1	Rider Temp High 1	Measured heating/cooling element temperature	<ul style="list-style-type: none"> Heating/cooling element damage Heating/cooling element above operating temperature limit Plug continuity 	<ul style="list-style-type: none"> Allow seat to cool to room temperature Verify plug is clean and fully seated See dealer
3	2	Under Voltage 1	Measured input connector voltage	<ul style="list-style-type: none"> Voltage at seat connector High 	<ul style="list-style-type: none"> Verify vehicle charging system and vehicle battery are healthy Verify seat's main power plug is clean and fully seated See dealer
3	3	Over Voltage	Measured input connector voltage	<ul style="list-style-type: none"> Voltage at seat connector High 	<ul style="list-style-type: none"> Verify vehicle charging system and vehicle battery are healthy See dealer
3	4	Rider Low Temp 1	Measured heating/cooling element temperature	<ul style="list-style-type: none"> Heating/cooling element damage Heating/cooling element below operating temperature limit Plug continuity 	<ul style="list-style-type: none"> Allow seat to warm to room temperature Verify plug is clean and fully seated See dealer
3	5	Passenger High Temp 1	Measured heating/cooling element temperature	<ul style="list-style-type: none"> Heating/cooling element damage Heating/cooling element above operating temperature limit Plug continuity 	<ul style="list-style-type: none"> Allow seat to cool to room temperature Verify plug is clean and fully seated See dealer
3	6	Passenger Low Temp 1	Measured heating/cooling element temperature	<ul style="list-style-type: none"> Heating/cooling element damage Heating/cooling element below operating temperature limit Plug continuity 	<ul style="list-style-type: none"> Allow seat to warm to room temperature Verify plug is clean and fully seated See dealer
3	8	Passenger Switch Level High	Passenger knob voltage	<ul style="list-style-type: none"> Plug continuity Switch Pack damage 	<ul style="list-style-type: none"> Verify plug is clean and fully seated See dealer

Table 1. Event Codes

LED	Flashes	Code	Detection	Possible Causes	Troubleshooting Actions
3	10	Rider Switch Level High	Rider knob voltage	<ul style="list-style-type: none"> • Plug continuity • Switch Pack damage 	<ul style="list-style-type: none"> • Verify plug is clean and fully seated • See dealer
3	11	Passenger Temp High 2	Measured heating/cooling element temperature	<ul style="list-style-type: none"> • Heating/cooling element damage • Heating/cooling element above operating temperature limit • Plug continuity 	<ul style="list-style-type: none"> • Allow seat to cool to room temperature • Verify plug is clean and fully seated • See dealer
3	12	Rider Temp High 2	Measured heating/cooling element temperature	<ul style="list-style-type: none"> • Heating/cooling element damage • Heating/cooling element above operating temperature limit • Plug continuity 	<ul style="list-style-type: none"> • Allow seat to cool to room temperature • Verify plug is clean and fully seated • See dealer
3	13	Under Voltage 2	Measured input connector voltage	<ul style="list-style-type: none"> • Voltage at seat connector low 	<ul style="list-style-type: none"> • Verify vehicle charging system and vehicle battery are healthy • Verify seat's main power plug is clean and fully seated • See dealer

TROUBLESHOOTING

NOTE

- If operation is not as expected the following steps should be completed.
- If heating or cooling becomes uncomfortable, reduce level by rotating knob toward OFF.

If vehicle is in motion:

1. Toggle heat/cool control switch, wait two seconds before returning to heat or cool mode.
2. If not traveling with a passenger, turn passenger control switch to OFF.

If vehicle is not in motion with engine off and battery fully charged:

1. Check seat's harness fuse.
 - a. If fuse is open, replace fuse with service part listed in Table 2. Do not replace this fuse with a higher rating.
 - b. If fuse continues to open, see dealer.
2. Operate seat.
 - a. Maintain power to seat plug while accessing RIO-ESC to view event code history from controller.
 - b. Because seat operates rider and passenger heating/cooling elements individually and in series, identifying the issue may require operating rider only, passenger only, or combination of both to verify the concern.

3. Record event codes on RIO-ESC.
 - a. These are visible by unclipping the seat RIO-ESC from seat base.
 - b. See Figure 7 and Table 1 for details on event codes. Several events are interrelated.
 - c. It is recommended to continue the following steps regardless of event code.
4. Visually inspect fans for operation and blockage.
 - a. Do not touch fan blade. Fan blade may cause bodily injury if operating or operation suddenly begins.
 - b. Do not insert objects into fan. This can damage the fan and cause bodily injury if operation suddenly begins.
 - c. Both fans operate when either control knob is set to a cooling mode above off. Some events will turn fans off.
 - d. Unplug fans before clearing a blockage. Fans rotate with little resistance when not powered.
5. If fans are damaged, see REPAIR section. Install fans and verify connector grommets are in place before connecting plugs.
6. Set both seat sections to OFF. Cycle power to seat plug.
7. Set seat to mode of concern and note events.
 - a. This will verify only persistent events are reported.
 - b. See Figure 1 for further troubleshooting actions.

NOTE

- When inspecting connector contacts for debris build-up, verify gasket surfaces of connectors are clean, gaskets are installed and gaskets are seated before inserting plug. Do not clean contacts with abrasives or fluids not recommended for tinned copper contacts, plastic or silicone rubber.
- A battery charger may be necessary to prevent battery from discharging while troubleshooting.
- Both heating/cooling sections contain a self-resetting inline fuse that limits high temperature operating conditions. If these fuses open, they will close when temperatures return to normal operating levels. This may take 3 minutes to self-clear in average temperature and shaded conditions.
- Power cycling is defined by completely removing power to seat. Either by removing and reconnecting seat plug or by turning vehicle fully off to verify power to seat is removed.
- Controller damage or mis-operation is a possible cause for all event codes and is not explicitly listed in every entry. Trouble shooting actions may require dealer assistance.

REPAIR

NOTE

Before replacing fan, remove seat. Power seat in cooling mode to visually inspect function of fans to verify which fan is malfunctioning.

Rider side fan is installed to the plug without striped wires. Passenger fan is installed to the plug with striped wires. When installed correctly, fan 1 is rider side while fan 2 is passenger side.

1. Figure 8

Passenger fan replacement.

NOTE

Before replacing fan, remove seat. Power seat in cooling mode to visually inspect function of fans to verify which fan is malfunctioning.

- a. Remove grab strap and rear seat tab screw (6).
- b. Remove seat. Careful not to pull on wiring connection between seat and vehicle.
- c. Disconnect seat wiring harness from vehicle.
- d. Remove screws (5). Retain.

NOTE

Note routing of wiring with respect to seat base. Disconnect fan from seat wiring harness.

- e. Install replacement fan (3) in seat base.
- f. Install screws (5). Tighten.
Torque: 0.564–0.79 N·m (5–7 in-lbs)

NOTE

- Verify wires are routed the same as they were originally installed.
- Replace any cable straps (7) previously removed.
- g. Connect fan to seat wiring harness.

- h. Connect seat wiring harness (1) to vehicle.
- i. Start vehicle or turn to accessory mode.
- j. Figure 6 Power seat in cooling mode to verify that the fan is working.
- k. Install seat. Pull up on seat to verify that it is secure. See service manual.

NOTE

Turn OFF vehicle before completing installation on vehicle.

- l. Install rear seat tab screw (6).
 - m. Install grab strap.
- #### 2. Figure 8

Rider duct assembly replacement.

NOTE

Before replacing duct, remove seat from vehicle and visually inspect duct for damage. If duct is cracked or broken such that airflow can leak directly to fan (bypassing cooling circuits), or fan is malfunctioning, then replace duct/fan assembly.

- a. Remove grab strap and rear seat tab screw.
- b. Remove seat. Careful not to pull on wiring connection between seat and vehicle.
- c. Disconnect seat wiring harness (1) from vehicle.
- d. Remove screws (2). Retain.

NOTE

Note routing of wiring with respect to seat base. Disconnect fan from seat wiring harness.

- e. Remove duct assembly (4) from seat.
- f. Connect **new** duct assembly fan connector to wiring harness.
- g. Install **new** duct assembly (4) to seat base.
- h. Install screws (2). Tighten.
Torque: 0.564–0.79 N·m (5–7 in-lbs)

NOTE

- Install side toward rider first, then rotate back of duct into place making sure that wiring harness is retained by the tab on duct.
- Verify wires are routed the same as they were originally installed.
- Replace any cable straps (7) previously removed.
- Do not over torque these screws. Over torquing will cause stripping of threads in seat base.

- i. Connect seat wiring harness (1) to vehicle.
- j. Start vehicle or turn to accessory mode.

k. Figure 6 Power seat in cooling mode (2) to verify that the fan is working.

l. Install seat. After installing seat, pull up on the seat to verify that it is secure. See service manual.

NOTE

Turn OFF vehicle before completing installation on vehicle.

m. Install rear seat tab screw (6).

n. Install grab strap.

3. See Figure 10 and Figure 8. RIO-ESC replacement.

a. Remove grab strap and rear seat tab screw (6).

b. Remove seat. Careful not to pull on wiring connection between seat and vehicle.

c. Disconnect seat wiring harness (1) from vehicle.

d. Remove cable strap (7) adjacent to RIO-ESC (10). Discard.

e. Using a flat head screwdriver, gently pry back on RIO-ESC retention tab (9) on seat base while pulling RIO-ESC (10) out of its slot in seat base.

f. Move lock on wiring harness connector (8) to unlocked position.

g. Firmly press plug retention tab in to enable wiring harness to be disconnected from RIO-ESC (10).

h. Figure 9 Using a 50:50 mixture of isopropyl/water clean back surface of RIO-ESC and allow surface to dry completely before attaching foam block.

i. Figure 9 Remove backing from foam block (13) and apply to back side of RIO-ESC (10) under LED lights.

j. Connect **new** RIO-ESC (10) to wiring harness (8).

k. Move lock on wiring harness (8) to locked position.

l. Insert RIO-ESC (10) into slot in seat base until RIO-ESC retention tab (9) on seat base locks RIO-ESC into place.

m. Attach **new** cable strap (7) between wiring harness (8) and seat base adjacent to RIO-ESC (10).

n. Connect seat wiring harness (1) to vehicle.

o. Start vehicle or turn to accessory mode.

p. Figure 6 Power seat in cooling mode to verify that the fan is working.

q. Install seat. After installing seat, pull up on seat to verify that it is secure. See service manual.

NOTE

Turn OFF vehicle before completing installation on vehicle.

r. Install rear seat tab screw.

s. Install grab strap.

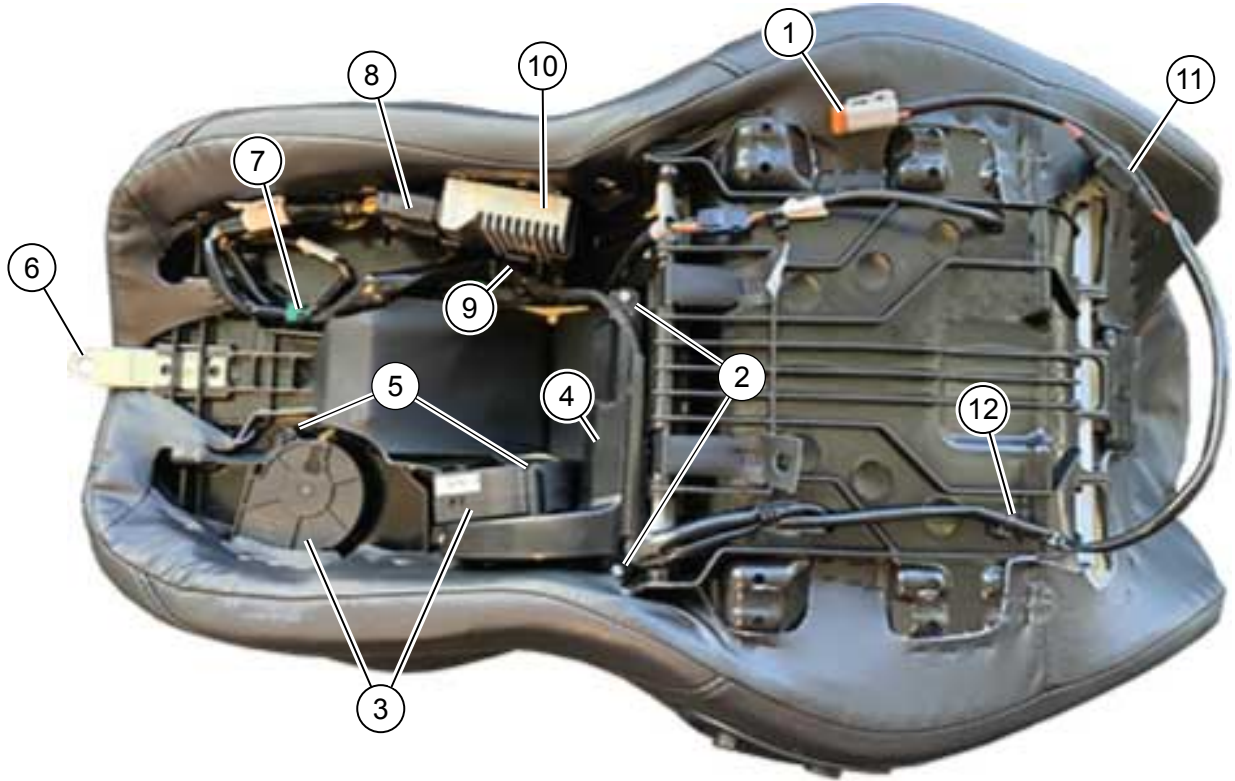

- | | |
|-------------------|--------------------------|
| 1. Seat harness | 7. Cable strap (3) |
| 2. Duct screw (3) | 8. RIO-ESC harness |
| 3. Fan (2) | 9. RIO-ESC retention tab |
| 4. Duct | 10. RIO-ESC |
| 5. Fan screw (4) | 11. Fuse, seat harness |
| 6. Seat tab | 12. Retainer Clip (3) |

Figure 8. Heated/Cooled Seat

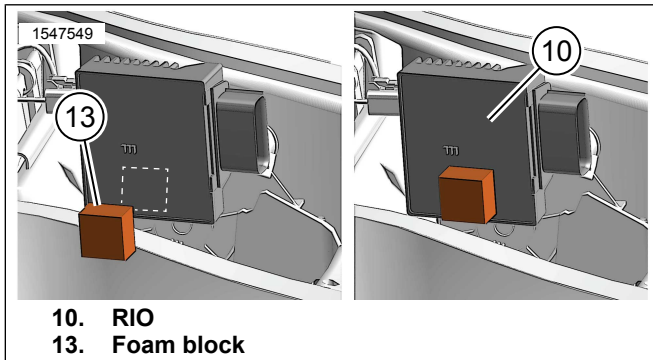

- | |
|----------------|
| 10. RIO |
| 13. Foam block |

Figure 9. Install Foam Block to RIO

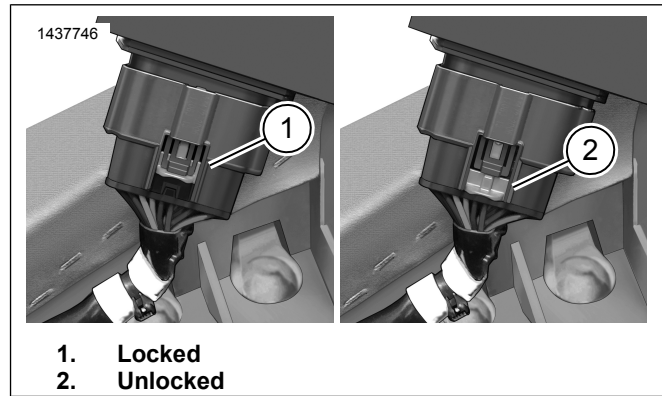

- | |
|-------------|
| 1. Locked |
| 2. Unlocked |

Figure 10. RIO Connector Locked/Unlocked Position

SERVICE PARTS

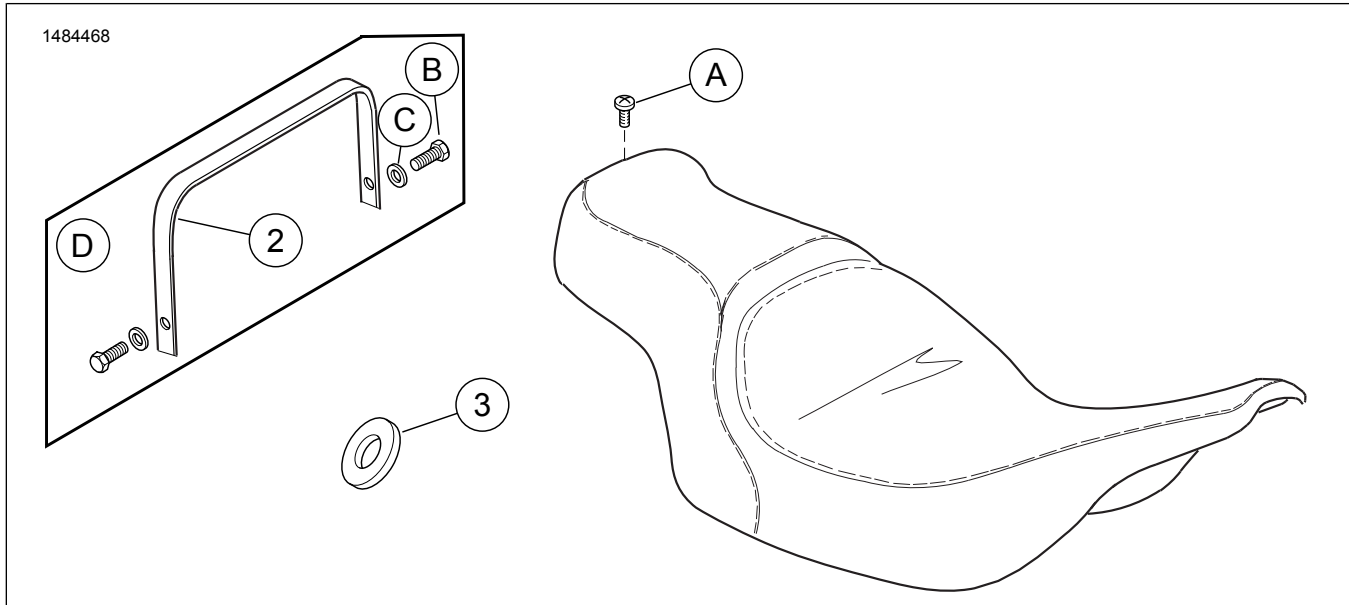

Figure 11. Service Parts: Heated Seat

Table 2. Service Parts Table

Item	Description (Quantity)	Part Number
1	Seat (plain pattern shown)	Not sold separately
2	Grab strap	52400296
3	Spacer (2)	10300256
See Figure 8 for the following items:		
2	Screw, duct (3)	10200557
3	Fan (2)	26800204
4	Duct assembly	52000488
7	Cable tie (3)	10006
5	Screw, fan (4)	10201028
10	RIO-ESC	41000740
11	Fuse, seat harness	69200293
12	Retainer clip (3)	10177
13	Foam block (See Figure 9)	52000635
Items mentioned in text, but not included in kit:		
A	Original equipment (OE) Phillips-head screw	2952A
B	OE Grab strap screw (2)	2952A
C	OE Grab strap washer (2)	6703
D	2014 and later model configuration	