

PAN AMERICA MODELS

2021 HARLEY-DAVIDSON® OWNER'S MANUAL



Harley-Davidson Motor Company
Service Communications
Milwaukee WI 53208 USA

2025-02-26



94000788EN

English

Printed in the USA

2021 HARLEY-DAVIDSON® OWNER'S MANUAL
PAN AMERICA MODELS - 94000788EN



94000788EN

PAN AMERICA MODELS

2021 HARLEY-DAVIDSON® OWNER'S MANUAL

TABLE OF CONTENTS

INTRODUCTION

Your Owner's Manual.....	1
We Care About You.....	1
United States Owners.....	1
Customer Service Assistance.....	1

SAFETY FIRST

Safety Definitions.....	3
Safe Operating Rules.....	3
Intended Use.....	3
Off-Road Riding.....	4
General.....	4
Operation.....	5
Steering and Handling.....	6
Accessories and Cargo.....	7
Tires.....	7
Towing and Trailering.....	8
Fuel and Exhaust.....	8
Brakes.....	9
Battery.....	10
Hazardous Materials.....	11
Maintenance.....	11
Parts and Accessories.....	11
Rules of the Road.....	12
Noise Control System.....	13

Tampering.....	13
Safety Symbol Definitions.....	13
Labels.....	17

YOUR MOTORCYCLE

Vehicle Identification Number (VIN).....	21
General.....	21
Location.....	21
Abbreviated VIN.....	21
Models and Features.....	24
Primary Controls and Service Components.....	24

SPECIFICATIONS

Specifications.....	29
Tires.....	29
Weights and Dimensions.....	30
Capacities.....	31
Engine and Transmission.....	31
Electrical.....	31

BEFORE RIDING

Removing Motorcycle from Storage.....	33
Pre-Ride Checklist.....	33
Break-in Riding Rules.....	34
The First 500 Miles (800 Kilometers).....	34
Filling the Fuel Tank.....	35

TABLE OF CONTENTS

FUEL FILLER CAP.....	35	Semi-Active Suspension.....	50
Fuel System Information.....	37	Adjusting Electronic Suspension.....	50
Gasoline.....	37	Manual Suspension.....	51
Catalytic Converter.....	39	Rear Shock.....	51
ABS Brake System Identification.....	39	Front Fork.....	54
Identification.....	39	SECURITY SYSTEM	
Checking Tire Pressure and Inspecting Tires.....	39	Security System.....	59
General Information.....	39	Components.....	59
Tire Pressure.....	40	Options.....	59
Inspecting Tires.....	42	Security System Fob.....	59
Replacing Tires.....	43	Assigning Fob.....	59
Adjusting Mirrors.....	44	Fob Battery.....	60
Operating Jiffy Stand.....	44	Riding with a Fob.....	61
Location.....	44	Riding without a Fob.....	61
Jiffy Stand Switch (If equipped).....	44	Personal Identification Number (PIN).....	62
Operating Center Stand.....	45	Changing the PIN.....	62
Using Center Stand.....	45	Arming and Disarming.....	64
Storing Center Stand.....	45	Arming.....	64
Suspension Adjustments.....	46	Disarming.....	64
Suspension Identification.....	46	Disarming with a PIN.....	65
Suspension Definitions.....	47	Alarm.....	67
Suspension Tuning.....	48	Warnings.....	67
Changes in Load.....	48	Alarm Activation.....	67
Electronic Suspension.....	49	Alarm Deactivation.....	67
Enhanced Semi-active Suspension.....	49		

TABLE OF CONTENTS

Tire Pressure/TPMS Fault Indicator.....	83	Hazard Warning 4-Way Flasher.....	91
Traction Control Indicator.....	83	Mode.....	91
Bluetooth Indicator.....	84	OFF.....	91
Bluetooth Application Status Indicator.....	84	RUN.....	91
Device Battery Indicator.....	84	Start.....	92
Device Signal Indicator.....	84	Previous.....	92
Headset Connection Indicator.....	84	Next.....	92
Left Hand Control Switches.....	86	Play/pause.....	92
Headlamp Switch.....	86	Volume up.....	92
Cruise control ON.....	86	Volume down.....	92
Cruise control OFF.....	86	Voice recognition.....	92
Cruise control set/decrease speed.....	86	Traction control.....	92
Cruise control resume/increase speed.....	86	Infotainment.....	95
Heated hand grips (if equipped).....	87	SAFETY.....	95
Trip.....	87	CONTROLS.....	95
Home.....	87	BLUETOOTH.....	96
Menu.....	87	PHONE.....	97
Navigate left.....	87	VOICE RECOGNITION.....	98
Navigate up.....	87	NAVIGATION.....	98
Navigate right.....	87	Bike Status.....	99
Navigate down.....	87	Widgets.....	100
Turn signals/cancel.....	87	Trip.....	100
Horn.....	88	Bike Status.....	100
OK/enter.....	88	Audio.....	100
Right Hand Control Switches.....	91	Navigation.....	100

TABLE OF CONTENTS

TPMS.....	100	Hill Hold Control (HHC).....	113
Ride Modes.....	100	Tire Pressure Monitoring System (TPMS).....	113
Ride Modes.....	100	ABS: Tires and Wheels.....	113
Setting Custom Ride Mode.....	103	115
Electronic Throttle Control (ETC).....	104	Traction Control.....	115
ETC Limited Performance Mode.....	105	Traction Control (TCS), Cornering Enhanced Traction Control (C-TCS), and Front Lift Mitigation (FLM).....	115
ETC Power Management Mode.....	105	How Cornering Enhanced Traction Control Works.....	115
ETC Forced Idle Mode.....	105	How To Use Traction Control.....	116
ETC Forced Shut Down Mode.....	105	Cornering Enhanced Drag-Torque Slip Control System (C-DSCS).....	116
HEATED HAND GRIPS.....	105	Shifting Gears.....	117
USB Port.....	106	Stopped, Engine Off.....	117
Heated Gear Connector.....	107	Starting from a Stop.....	118
Starting the Engine.....	108	Upshift (Acceleration).....	118
General.....	108	Downshift (Deceleration).....	119
Starting.....	108	WINDSHIELD.....	120
Starting after Tipover.....	109	Raise.....	120
Stopping the Engine.....	109	Lower.....	121
Cornering Rider Safety Enhancements.....	109	AFTER RIDING	
Front Brake Lever.....	109	Genuine Motor Parts and Accessories.....	123
Rear Brake Pedal.....	110	Online Catalog.....	123
ABS, Cornering Enhanced ABS (C-ABS) and Rear Lift Mitigation (RLM) Functions.....	111	Shop for Your Bike.....	123
How ABS Works.....	112	Cleaning and General Care.....	123
Cornering Enhanced Electronic Linked Braking (C-ELB).....	112	Cleaning Wheels and Tires.....	124
How To Use ABS.....	112		

TABLE OF CONTENTS

Radiator.....	124	OIL COOLER.....	142
Recommended Cleaning Products.....	124	Inspecting Brake Pads and Discs.....	143
Washing the Motorcycle.....	129	Brake Pads.....	143
Preparation.....	129	Brake Disc.....	145
Cleaning Wheels and Tires.....	129	Checking Systems for Leaks or Abrasions.....	145
Washing the Motorcycle.....	130	Checking Brake Fluid Level and Changing Brake Fluid....	145
Drying the Motorcycle.....	130	Checking Brake Fluid Level.....	145
Polishing and Sealing.....	130	Changing Brake Fluid.....	146
Windshield Care.....	131	Checking Clutch and Brake Controls.....	147
Leather and Vinyl Care.....	132	Clutch Hand Lever.....	147
Exhaust Care.....	132	Brake Hand Lever.....	147
Storing Motorcycle.....	133	Miscellaneous Lubrication.....	148
MAINTENANCE AND LUBRICATION		Check Drive Chain and Sprockets.....	148
Maintenance.....	135	Inspect Drive Chain.....	148
Break-in Maintenance.....	135	Measure Drive Chain Deflection.....	148
Preparing the Motorcycle for Maintenance.....	135	Clean and Lubricate.....	150
Setting Motorcycle Upright.....	136	Inspect Front and Rear Sprockets.....	150
Lifting Motorcycle.....	136	Inspect Chain Guide.....	150
Disposal and Recycling.....	136	Mechanical Clutch.....	151
Engine Lubrication.....	137	Coolant.....	152
Engine Lubrication.....	137	General.....	152
Low Temperature Lubrication.....	138	Checking Coolant Level.....	152
Check Engine Oil Level.....	138	Checking Coolant Freeze Point.....	153
Change Oil and Oil Filter.....	140	Cleaning Radiator.....	153
		Replacing Coolant.....	154

TABLE OF CONTENTS

Maintaining Front Fork.....	155	Install.....	169
Adjusting Steering Head Bearings.....	155	Headlamp.....	169
Shock Absorbers.....	155	Prepare.....	169
Spark Plugs.....	155	Check Alignment.....	170
Inspecting Air Filter.....	156	Adjustment.....	171
Lubricating Fuel Cap Lock.....	156	Replacing Headlamp.....	172
SERVICE PROCEDURES		Bank Angle Lamp.....	172
Battery Tender Connector.....	157	Check Bank Angle Lamp Alignment (If equipped).....	172
Battery Maintenance.....	157	Adjustment.....	173
Battery Safety.....	157	Tail Lamp Bulb Replacement: LED.....	173
Absorbed Glass Mat (AGM) Battery Charging Information.....	158	Turn Signal Bulb Replacement: LED.....	173
Cleaning and Inspecting.....	159	Seat.....	173
Charging and Storing the Battery.....	159	Removal.....	173
Battery Replacement.....	161	Installation.....	173
Removing Battery.....	161	FUSES.....	175
Installing Battery.....	161	Main Fuse.....	176
Side Covers.....	164	Fuse Block.....	176
Remove.....	164	TROUBLESHOOTING	
Install.....	164	Troubleshooting: General.....	179
Skid Plate.....	165	Engine.....	179
One Piece Skid Plate.....	165	Starter Does Not Operate or Does Not Turn Engine Over.....	179
Two Piece Skid Plate.....	167	Engine Turns Over But Does Not Start.....	179
Fairing.....	168	Starts Hard.....	179
Remove.....	168	Starts But Runs Irregularly or Misses.....	180

TABLE OF CONTENTS

A Spark Plug Fouls Repeatedly.....	180
Pre-ignition or Detonation (Knocks or Pings).....	180
Overheats.....	180
Excessive Vibration.....	180
Engine Oil Not Circulating (Oil Pressure Indicator Lit).....	180
Transmission.....	181
Transmission Shifts Hard.....	181
Transmission Jumps Out of Gear.....	181
Clutch Slips.....	181
Clutch Drags or Does Not Release.....	181
Clutch Chatters.....	181
Cooling System.....	181
Overheats.....	181
Electrical System.....	181
Alternator Does Not Charge.....	181
Alternator Charge Rate is Below Normal.....	181
Brakes.....	182
Brakes Do Not Hold Normally.....	182
WARRANTIES AND RESPONSIBILITIES	
Warranty and Maintenance.....	183
Keeping It All Harley-Davidson.....	183
California and Select International Markets Evaporative Emission Controls.....	184
EPA Noise Regulations in the United States.....	184

EPA Regulations.....	184
Warranty/Service Information.....	185
Reporting Safety Defects in the United States.....	185
NHTSA Statement.....	185
Required Documentation for Imported Motorcycles.....	186
Owner Contact Information.....	186
Questions and Concerns.....	186

LIMITED MOTORCYCLE WARRANTY

2021 HARLEY-DAVIDSON LIMITED MOTORCYCLE WARRANTY.....	189
24 Months/Unlimited Miles.....	189
Duration.....	190
Owner's Obligations.....	190
Exclusions.....	190
On-Road/Off-Road Vehicles.....	191
This limited warranty will not apply to any On-Road/Off-Road motorcycle.....	191
Other Limitations.....	191
Important: Read Carefully.....	193
Environmental Factors.....	194

TABLE OF CONTENTS

LIMITED MOTORCYCLE WARRANTY (AUSTRALIA)

2021 AUSTRALIA/NEW ZEALAND HARLEY-DAVIDSON MOTORCYCLE LIMITED WARRANTY.....	195
24 Months/Unlimited Miles.....	195
Your Consumer Rights.....	195
Warranty.....	195
Warranty Period.....	196
Obtaining Warranty Service.....	196
Exclusions.....	196
On-Road/Off-Road Vehicles.....	197
Other Limitations.....	197
Important: Read Carefully.....	199
Environmental Factors.....	199

LIMITED NOISE WARRANTY

2021 HARLEY-DAVIDSON MOTORCYCLE NOISE CONTROL SYSTEM LIMITED WARRANTY.....	201
Other Rights.....	202
Recommendations for Required Maintenance.....	202

LIMITED EMISSION WARRANTY

2021 HARLEY-DAVIDSON EMISSION CONTROL SYSTEM LIMITED WARRANTY.....	203
USA Owners 49 State Limited Emissions Warranty.....	203

Items Covered by this Emission Warranty.....	204
Other Rights.....	205
Recommendations for Required Maintenance.....	205

CALIFORNIA EMISSIONS CONTROL WARRANTY

California Emissions Control Warranty Statement.....	207
USA Owners California Limited Emissions Warranty.....	207
Your Warranty Rights and Obligations.....	207
Manufacturer's Warranty Coverage.....	207
Owner's Warranty Responsibilities.....	207
Additional Warranty Terms.....	208
What Is Covered by this Emission Warranty.....	209
What Is Not Covered by this Emission Warranty.....	209

SERVICE INTERVALS AND RECORDS

Service Records.....	211
Regular Service Intervals.....	211
Service Intervals.....	211
Service Actions.....	214
Maintenance Records.....	215

APPENDIX

General.....	217
Acronyms and Abbreviations.....	217
H-D U.S.A., LLC Trademark Information.....	219

TABLE OF CONTENTS

Product Registered Marks.....	219	Copyright.....	219
Patents.....	219		



YOUR OWNER'S MANUAL

We Care About You

Welcome to the Harley-Davidson Motorcycling Family! When enjoying your Harley-Davidson motorcycle, be sure to ride safely, respectfully and within the limits of the law and your abilities. Always wear a helmet, proper eyewear and protective clothing, and insist your passenger does too. Never ride while under the influence of alcohol or drugs. Know your Harley and read and understand your owner's manual from cover to cover.

This manual has been prepared to acquaint you with the operation, care and maintenance of your motorcycle and to provide you with important safety information. Follow these instructions carefully for maximum motorcycle performance and for your personal motorcycling safety and pleasure. Your Owner's Manual contains instructions for operation and minor maintenance. Major repairs are covered in the Harley-Davidson Service Manual. Such major repairs require the attention of a skilled technician and the use of special tools and equipment. Your Harley-Davidson dealer has the facilities, experience and Genuine Harley-Davidson parts necessary to properly render this valuable service. We recommend that any emission system maintenance be performed by an authorized Harley-Davidson dealer.

Attend a rider safety course. To enroll in a Harley-Davidson Riding Academy course, call 1-414-343-4056 (U.S.) or visit www.harley-davidson.com/learntoride. In the United States, for information about Motorcycle Safety Foundation rider courses, call 1-800-446-9227 or visit www.msf-usa.org.

United States Owners

Your Harley-Davidson motorcycle conforms to all applicable U.S. Federal Motor Vehicle Safety Standards and U.S. Environmental Protection Agency regulations effective on the date of manufacture. Protect your privilege to ride by joining the American Motorcyclist Association. Visit www.americanmotorcyclist.com for more information.

Harley-Davidson reserves the right to change specifications, equipment or designs at any time without notice and without incurring obligation.

CUSTOMER SERVICE ASSISTANCE

Most sales or service issues are resolved at the dealership.

1. Discuss your problem with the appropriate personnel at the dealership in the Sales, Service or Parts area. If that proves unsuccessful, speak to the owner of the dealership or the general manager.

2. If you cannot resolve the issue with the dealership, contact the Harley-Davidson Customer Support Center. Harley-Davidson Motor Company Attention: Harley-Davidson Customer Support Center P.O. Box 653 Milwaukee, Wisconsin 53201 1-800-258-2464 (U.S. only) 1-414-343-4056

For customers outside the US, contact your local Harley-Davidson market office, call 1-414-343-4056 or visit harley-davidson.com.

Table 1. Vehicle and Personal Data

PERSONAL INFORMATION	DEALER INFORMATION
Date of Purchase:	
Name:	Name:
Address:	Address:
Address:	Address:
Vehicle Identification Number:	Sales Contact:
Key Number:	Service Contact:

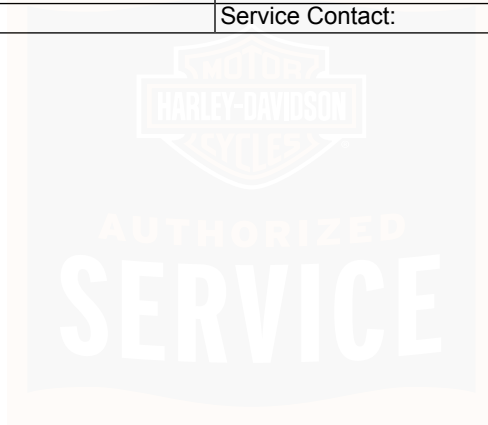

SAFETY DEFINITIONS

Statements in this manual preceded by the following words are of special significance:

▲ WARNING

WARNING indicates a potentially hazardous situation which, if not avoided, could result in death or serious injury. (00119a)

▲ CAUTION

CAUTION indicates a potentially hazardous situation which, if not avoided, may result in minor or moderate injury. (00139a)

NOTICE

NOTICE indicates a potentially hazardous situation which, if not avoided, may result in property damage. (00140b)

NOTE

Refers to important information and is placed in italic type. It is recommended that you take special notice of these items.

SAFE OPERATING RULES

▲ WARNING

Motorcycles are different from other vehicles. They operate, steer, handle and brake differently. Unskilled or improper use could result in loss of control, death or serious injury.

- Take a rider training course.
- Read owner's manual before riding, adding accessories or servicing.
- Wear a helmet, eye protection and protective clothing.
- Never tow a trailer.

(00556d)

Intended Use

This motorcycle is designed for on-road and moderate off-road use. This entails use on paved and gravel roads, or groomed trails, but does not include competition courses, rally routes, or similar use.

This vehicle is not equipped with a spark arrester. Operation or off-road usage in some areas may be restricted. Obey local laws and regulations.

Off-Road Riding

⚠ WARNING

Motorcycles handle differently in off-road environments. Unskilled or improper use could result in loss of control, death or serious injury.

- Take an appropriate off-road training course.
- Practice in a controlled environment before riding over unfamiliar terrain.
- Wear a helmet, eye protection and protective clothing.

(11709a)

- Operation off-road may present challenges such as unexpected turns, rocks, loose surfaces, and uneven terrain. Lower your speed to allow for additional time to react to these challenges.
- Weather conditions may impact the condition of off-road surfaces.
- Obey local off-road riding laws and regulations.
- Do not ride on private property without permission. Obey "No Trespassing" signs.
- Ride with a group to assist each other if trouble occurs.

- Perform the Pre-Ride Checklist when transitioning from off-road to on-road. Refer to: BEFORE RIDING > PRE-RIDE CHECKLIST (Page 33).
- The laced wheels are more durable than cast wheels in off-road conditions and are recommended for extensive off-road use.

General

⚠ WARNING

Consult a Harley-Davidson dealer regarding any questions or problems that occur in the operation of your motorcycle. Failure to do so can aggravate an initial problem, cause costly repairs, cause an accident and could result in death or serious injury. (00020a)

- Make sure all equipment required by federal, state and local law is installed and in good operating condition.
- Know and respect the rules of the road. Read the safety information that is provided by your state or regional traffic authority.
- In the United States, read the RIDING TIPS booklet that is provided with this owner's manual. Read the MOTORCYCLE HANDBOOK which is made available by your state or regional traffic authority.

- Protect your motorcycle against theft. Lock the front fork. Remove the key when parking your motorcycle.

⚠ WARNING

Do not add sidecar to this motorcycle. Operating motorcycle with sidecar can cause loss of vehicle control, which could result in death or serious injury. (00590d)

Operation

Before operating your new motorcycle, it is your responsibility to read and follow the operating and maintenance instructions in this manual and follow these rules for your personal safety.

- Before starting the engine, review the BEFORE RIDING > PRE-RIDE CHECKLIST (Page 33).

⚠ WARNING

Striking an object, such as a curb or pothole can cause internal tire damage. If an object is struck, have the tire inspected immediately inside and out by a Harley-Davidson dealer. A damaged tire can fail while riding and adversely affect stability and handling, which could result in death or serious injury. (00058b)

⚠ WARNING

Travel at speeds appropriate for road and conditions and never travel faster than posted speed limit. Excessive speed can cause loss of vehicle control, which could result in death or serious injury. (00008a)

- Do not exceed the legal speed limit or drive too fast for existing conditions. Always reduce speed when poor driving conditions exist. High speed increases the influence of any other condition affecting stability and increases the possibility of loss of control.
- Pay strict attention to road surfaces and wind conditions and keep both hands on the handlebar grips at all times when riding the motorcycle. Any two wheeled vehicle may be subject to upsetting forces such as wind blasts from passing trucks, holes in the pavement, rough road surfaces, rider control error, etc. These forces may influence the handling characteristics of your motorcycle. If this happens, reduce speed and guide the motorcycle with a relaxed grip to a controlled condition. Do not brake abruptly or force the handlebar. This may aggravate an unstable condition.
- New riders should gain experience under various conditions while riding at moderate speeds.
- Operate your motorcycle defensively. In an accident, a motorcycle does not afford the same protection as an automobile.

- It is the rider's responsibility to instruct passengers on proper riding procedures.
- Do not allow other individuals to operate the motorcycle unless they are experienced, licensed riders and are thoroughly familiar with the operation of the motorcycle.

⚠ WARNING

Brush guards and wind deflectors are not intended to provide protection from bodily injury in a collision with another vehicle or any other object. (11609b)

Steering and Handling

⚠ WARNING

Do not operate vehicle with forks locked. Locking the forks restricts the vehicle's turning ability, which could result in death or serious injury. (00035a)

⚠ WARNING

Regularly inspect shock absorbers and front forks. Replace leaking, damaged or worn parts that can adversely affect stability and handling, which could result in death or serious injury. (00012a)

⚠ WARNING

Do not operate motorcycle with loose, worn or damaged steering or suspension systems. Contact a Harley-Davidson dealer for repairs. Loose, worn or damaged steering or suspension components can adversely affect stability and handling, which could result in death or serious injury. (00011a)

⚠ WARNING

Do not open storage compartments while riding. Distractions while riding can lead to loss of control, which could result in death or serious injury. (00082a)

⚠ WARNING

When riding on wet roads, brake efficiency and traction are greatly reduced. Failure to use care when braking, accelerating or turning on wet roads can cause loss of control, which could result in death or serious injury. (00041a)

Accessories and Cargo

⚠ WARNING

Do not exceed the motorcycle's Gross Vehicle Weight Rating (GVWR) or Gross Axle Weight Rating (GAWR). Exceeding these weight ratings can lead to component failure and adversely affect stability, handling and performance, which could result in death or serious injury. (00016f)

- GVWR is the sum of the weight of the motorcycle, accessories and the maximum weight of the rider, passenger and cargo that can be safely carried.
- The GVWR is shown on the information label, located on the frame steering head or the frame downtube.
- GAWR is the maximum amount of weight that can be safely carried on each end of the motorcycle.
- For GVWR and GAWR, front and rear. See SPECIFICATIONS > SPECIFICATIONS (Page 29).
- Keep cargo weight concentrated close to the motorcycle and as low as possible.
- Distribute weight evenly on both sides of the vehicle.
- Do not load bulky items too far behind the rider or add weight to the handlebars or front forks.

- Do not exceed maximum specified load in each saddlebag (if equipped).
- Luggage racks (if equipped) are designed for lightweight items. Do not overload racks.
- Make sure cargo is secure. Make sure the cargo will not shift while riding and check the cargo periodically. Accessories that change the operator's riding position may increase reaction time and affect handling of the motorcycle.
- Large surfaces such as fairings, windshields, backrests and luggage racks (if equipped) can adversely affect on stability and handling.

Tires

⚠ WARNING

Be sure tires are properly inflated, balanced, undamaged, and have adequate tread. Inspect your tires regularly and see a Harley-Davidson dealer for replacements. Riding with excessively worn, unbalanced, improperly inflated, overloaded or damaged tires can lead to tire failure and adversely affect stability and handling, which could result in death or serious injury. (00014b)

⚠ WARNING

Replace punctured or damaged tires. In some cases, small punctures in the tread area may be repaired from within the removed tire by a Harley-Davidson dealer. Speed should NOT exceed 80 km/h (50 mph) for the first 24 hours after repair, and the repaired tire should NEVER be used over 129 km/h (80 mph). Failure to follow this warning could lead to tire failure and result in death or serious injury. (00015b)

Towing and Trailing

⚠ WARNING

Do not pull a trailer with a motorcycle. Pulling a trailer can cause tire overload, damage and failure, reduced braking performance, and adversely affect stability and handling, which could result in death or serious injury. (00018c)

⚠ WARNING

Do not tow a disabled motorcycle. Towing can adversely affect stability and handling, which could result in death or serious injury. (00017a)

Never tow a trailer.

Fuel and Exhaust

⚠ WARNING

Stop the engine when refueling or servicing the fuel system. Do not smoke or allow open flame or sparks near gasoline. Gasoline is extremely flammable and highly explosive, which could result in death or serious injury. (00002a)

⚠ WARNING

Avoid spills. Slowly open fuel filler cap. Do not fill above bottom of filler neck insert, leaving air space for fuel expansion. Secure filler cap after refueling. Gasoline is extremely flammable and highly explosive, which could result in death or serious injury. (00028b)

- Refuel in a well-ventilated area with the engine off.
- Open the fuel filler cap slowly.
- Do not fill fuel tank above the bottom of the filler neck insert. Leave air space to allow for fuel expansion.
- If fuel tank was completely drained, add at least 1 gal (3.79 L) of gas.

⚠ WARNING

Avoid contact with exhaust system and wear protective clothing that completely covers legs while riding. Exhaust pipes and mufflers get very hot when engine is running and remain too hot to touch, even after engine is turned off. Failure to wear protective clothing could result in burns or other serious injury. (00009a)

⚠ WARNING

Do not run motorcycle in a closed garage or confined area. Inhaling motorcycle exhaust, which contains poisonous carbon monoxide gas, could result in death or serious injury. (00005a)

⚠ WARNING

Engine exhaust from this product contains chemicals known to the State of California to cause cancer, and birth defects or other reproductive harm. (00004f)

Brakes

⚠ WARNING

Brakes are a critical safety component. Contact a Harley-Davidson dealer for brake repair or replacement. Improperly serviced brakes can adversely affect brake performance, which could result in death or serious injury. (00054a)

⚠ WARNING

Apply front and rear brakes evenly. Favoring one brake accelerates wear and reduces braking efficiency. Operation with excessively worn brakes can lead to brake failure, which could result in death or serious injury. (00135a)

⚠ WARNING

Contact with DOT 4 brake fluid can have serious health effects. Failure to wear proper skin and eye protection could result in death or serious injury.

- If inhaled: Keep calm, remove to fresh air, seek medical attention.
- If on skin: Remove contaminated clothing. Rinse skin immediately with plenty of water for 15-20 minutes. If irritation develops, seek medical attention.

- **If in eyes: Wash affected eyes for at least 15 minutes under running water with eye lids held open. If irritation develops, seek medical attention.**
- **If swallowed: Rinse mouth and then drink plenty of water. Do not induce vomiting. Contact Poison Control. Immediate medical attention required.**
- **See Safety Data Sheet (SDS) for more details available at sds.harley-davidson.com**

(00240e)

⚠ WARNING

DOT 4 brake fluid absorbs moisture from the atmosphere over time, changing the properties of the fluid. Check brake fluid moisture content at every service interval or annually (whichever comes first). Flush and replace the brake fluid every two years, or sooner if moisture content is 3% or greater. Failure to flush and replace fluid can adversely affect braking, which could result in death or serious injury. (06304b)

To ensure the brake system is performing to design, check the moisture content of the brake fluid at every service interval or at least annually using a DOT 4 brake fluid moisture tester (part number HD-48497-A or equivalent) following the instructions included with the tool. Flush DOT 4 fluid every 2

years or sooner if the brake system fluid test shows moisture content is 3% or greater.

Harley-Davidson recommends using Harley-Davidson Platinum Label DOT 4 Brake Fluid because of its superior moisture and corrosion inhibiting properties

Battery

⚠ WARNING

Batteries, battery posts, terminals and related accessories contain lead and lead compounds, and other chemicals known to the State of California to cause cancer, and birth defects or other reproductive harm. Wash hands after handling. (00019e)

⚠ WARNING

Batteries contain sulfuric acid, which could cause severe burns to eyes and skin. Wear a protective face shield, rubberized gloves and protective clothing when working with batteries. KEEP BATTERIES AWAY FROM CHILDREN. (00063a)

NOTICE

It is possible to overload the vehicle's charging system by adding too many electrical accessories. If the combined electrical accessories operating at any one time consume more electrical current than the vehicle's charging system can produce, the electrical consumption can discharge the battery and cause damage to the vehicle's electrical system. (00211d)

Hazardous Materials

⚠ CAUTION

Prolonged or repeated contact with used motor oil may be harmful to skin and could cause skin cancer. Promptly wash affected areas with soap and water. (00358b)

Maintenance

⚠ WARNING

Perform the service and maintenance operations as indicated in the regular service interval table. Lack of regular maintenance at the recommended intervals can affect the safe operation of your motorcycle, which could result in death or serious injury. (00010a)

- A new motorcycle must be operated according to the special break-in procedure. See BEFORE RIDING > BREAK-IN RIDING RULES (Page 34).
- Proper care and maintenance, including tire pressure, tire condition, tread depth and proper adjustment to steering head bearings are important to stability and safe operation of the motorcycle. See SERVICE INTERVALS AND RECORDS > SERVICE RECORDS (Page 211).

Parts and Accessories

⚠ WARNING

Harley-Davidson parts and accessories are designed for Harley-Davidson motorcycles. Using non-Harley-Davidson parts or accessories can adversely affect performance, stability or handling, which could result in death or serious injury. (00001b)

- Use only Harley-Davidson approved parts and accessories. Use of certain other manufacturer's performance parts will void your new motorcycle warranty. See your Harley-Davidson dealer for details.

⚠ WARNING

Use Harley-Davidson replacement fasteners. Aftermarket fasteners can adversely affect performance, which could result in death or serious injury. (00013a)

- See your Harley-Davidson service manual for proper torque values.
- Aftermarket fasteners may not have the specific property requirements to perform properly.

▲ WARNING

See ACCESSORIES AND CARGO section within the SAFETY FIRST section in your owner's manual. Improper cargo loading or accessory installation can cause component failure and adversely affect stability, handling and performance, which could result in death or serious injury. (00021c)

- Harley-Davidson Motor Company cannot test and make specific recommendations concerning every accessory or combination of accessories sold. Therefore, the rider must be responsible for safe operation of the motorcycle when installing accessories or carrying additional weight.
- Additional electrical equipment may overload the electrical system possibly resulting in electrical system and/or component failure.

RULES OF THE ROAD

- Always use your turn signals and exercise caution when passing other vehicles going in the same direction. Never pass going in the same direction at street intersections, on curves or when going up or down a hill.

- At street intersections, give the right-of-way. Do not presume you have the right-of-way, as the other driver may not know that it is your turn.
- Always signal when preparing to stop, turn or pass.
- Promptly obey all traffic signs, including those signs used for the control of traffic at intersections. Always obey traffic signs near schools and at railroad crossings.
- When intending to turn, signal at least 30.5 m (100 ft) before reaching the turning point. If turning across an intersection, move over to the centerline of the street (unless local rules require otherwise). Slow down when entering the intersection and turn carefully.
- Never anticipate a traffic light. When a change is indicated from GO to STOP (or STOP to GO), slow down and wait for the light to change. Never run through a yellow or red traffic light.
- While turning, watch for pedestrians, animals, as well as vehicles.
- Do not leave the curb or parking area without signaling. Make sure that your way is clear to enter moving traffic. A moving line of traffic always has the right-of-way.
- Make sure that your license plate is installed in the position specified by law. Make sure that your license plate is always clearly visible. Keep the license plate clean.

- Ride at a safe speed that is consistent with the type of highway you are on. Pay strict attention to whether the road is dry, oily, icy or wet.
- Watch for debris such as leaves or loose gravel.
- Weather and traffic conditions on the highway dictate adjusting your speed and driving habits accordingly.

NOISE CONTROL SYSTEM

Tampering

Removal or replacement of any noise control system component may be prohibited by law. This prohibition includes modifications made prior to vehicle sale or delivery to the ultimate purchaser. Use of a vehicle on which noise control system components have been removed or rendered inoperative may also be prohibited by law.

SAFETY SYMBOL DEFINITIONS

These are some of the symbols that you may see on your motorcycle and may accompany safety words, see SAFETY FIRST > SAFETY DEFINITIONS (Page 3). The symbols indicate potential safety hazards and avoidance actions to prevent a hazardous situation. The symbols may be present in manuals, instructions, on the motorcycle and/or Parts & Accessory product labels. Refer to SAFETY FIRST > SAFE OPERATING RULES (Page 3), the appropriate section in this manual and/or Parts & Accessory instructions for additional safety information.

- Yellow triangle: Safety symbol alerting to a hazard. Table 2
- Red circle with line: Prohibition symbol to avoid a situation which may lead to a hazard, personal injury and/or property damage. Table 3
- Blue circle: Mandatory action to avoid a hazard resulting in personal injury and/or property damage. Table 4

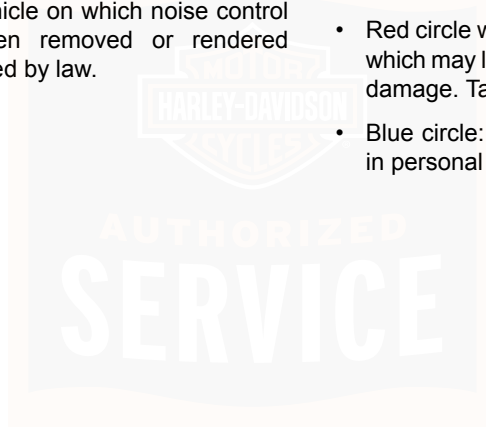









Table 2. General Warning Symbols

SYMBOL	SYMBOL DEFINITION	SYMBOL	SYMBOL DEFINITION
	General Warning indicating a hazard.		Explosive material hazard.
	Crash hazard.		Corrosive chemical burn hazard.
	Electric shock hazard.		Hot surface hazard.
	Battery charging hazard.		

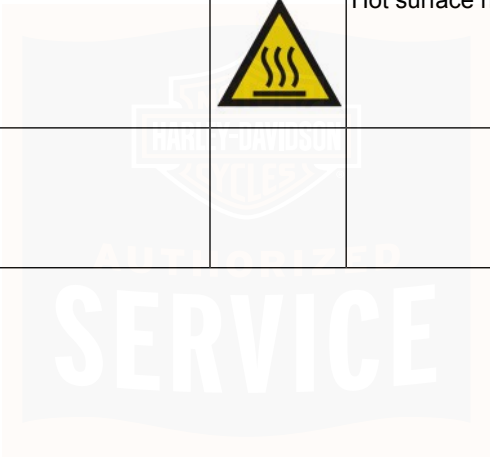

Table 3. General Prohibition Symbols

















SYMBOL	SYMBOL DEFINITION	SYMBOL	SYMBOL DEFINITION
	General prohibition sign to signify a prohibited action.		Do not expose to fire.
	Do not service without proper training or tools. Qualified technician only. Not user serviceable. No user replaceable parts. Refer service to qualified technician.		Do not perform action above indicated temperature.
	Do not touch.		Never tow a trailer.
	Keep away from open flame. Avoid smoking, flames, or sparks.		Do not use an extension cord.
	Do not add weight.		

Table 4. General Mandatory Action Symbols

SYMBOL	SYMBOL DEFINITION	SYMBOL	SYMBOL DEFINITION
	General mandatory action.		Wear proper protective riding gear.
	Refer to appropriate manual or instructions.		Wear proper hand protection.
	Take a rider training course.		Wear proper Personal Protective Equipment (PPE).
	Wear a helmet and eye protection.		Wear proper eye protection.

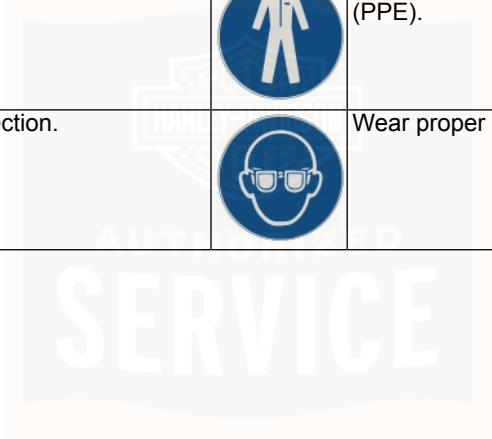



Table 5. General Information Symbols

SYMBOL	SYMBOL DEFINITION
	First responder cut loop. Emergency Personnel/First Responder use only.
	Protect from rain or wet conditions.

LABELS

See Figure 1 for safety and maintenance labels which were on the vehicle when new. Refer to Table 6.

NOTE

Replacement labels can be purchased for your motorcycle. See a Harley-Davidson dealer. Some labels are available in different languages for destinations outside the United States.

Refer to SAFETY FIRST > SAFETY SYMBOL DEFINITIONS (Page 13) for definitions of symbols on labels.

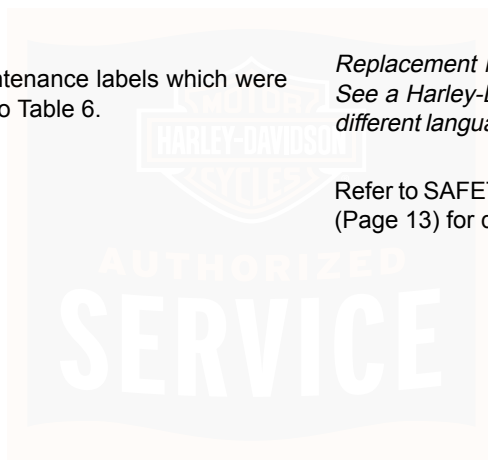

1530110

▲ WARNING

Motorcycles are different from other vehicles. They operate, steer, handle and brake differently. Unskilled or improper use could result in loss of control, death or serious injury.

- Take a rider training course.
- Read Owner's Manual before riding, adding accessories or servicing.
- Wear a helmet, eye protection and protective clothing.
- Never tow a trailer.

For a manual, find nearest dealer at 1-414-343-4056 or www.harley-davidson.com

LOAD CAPACITY
5.5 LBS (2.5 KG) MAX.

14002804
14002804
14002804

1



3

2

▲ WARNING

A connected battery can cause a spark or motorcycle startup while servicing. Death or serious injury could occur.

- Disconnect negative cable before servicing.
- Keep cable away from terminal while servicing.

15368-01A

4

Figure 1. Labels

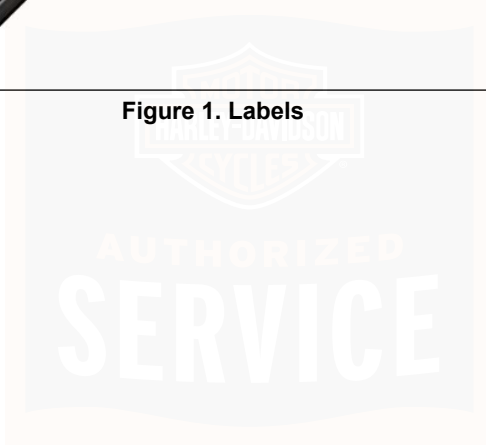

Table 6. Labels

ITEM	PART NO.	DESCRIPTION	LOCATION	TEXT
1	14001624	General warning	Top of chain guard	<p>WARNING: Motorcycles are different from other vehicles. They operate, steer, handle and brake differently. Unskilled or improper use could result in loss of control, death or serious injury.</p> <ul style="list-style-type: none">• Take a rider training course.• Read Owner's Manual before riding, adding accessories or servicing.• Wear a helmet, eye protection and protective clothing.• Never tow a trailer. <p>For a manual, find nearest dealer at 1-414-343-4056 or www.harley-davidson.com</p>
2	14002804	Rack load limit	On rear rack	<p>LOAD CAPACITY 5.5 LBS (2.5 KG) MAX</p>
3	26800086	Radiator warning	On radiator cap	<p>WARNING: HOT FLUID WILL SCALD YOU 1.4 BAR DO NOT remove cap when engine is hot</p>
4	15368-01A	Battery warning	On voltage regulator bracket	<p>WARNING: A connected battery can cause a spark or motorcycle startup while servicing. Death or serious injury could occur.</p> <ul style="list-style-type: none">• Disconnect negative cable before servicing.• Keep cable away from terminal while servicing.

NOTES



VEHICLE IDENTIFICATION NUMBER (VIN)

General

See Figure 3. A unique 17-digit serial or Vehicle Identification Number (VIN) is assigned to each motorcycle. Refer to Table 7.

Location

See Figure 2. The full 17-digit VIN is stamped on the right side of the frame near the steering head. In some destinations, a printed VIN label is also attached on the front downtube.

Abbreviated VIN

An abbreviated VIN showing the vehicle model, engine type, model year, and sequential number is stamped on the left side of the crankcase below the gear shifter.

NOTE

Always give the full 17-digit Vehicle Identification Number when ordering parts or making any inquiry about your motorcycle.

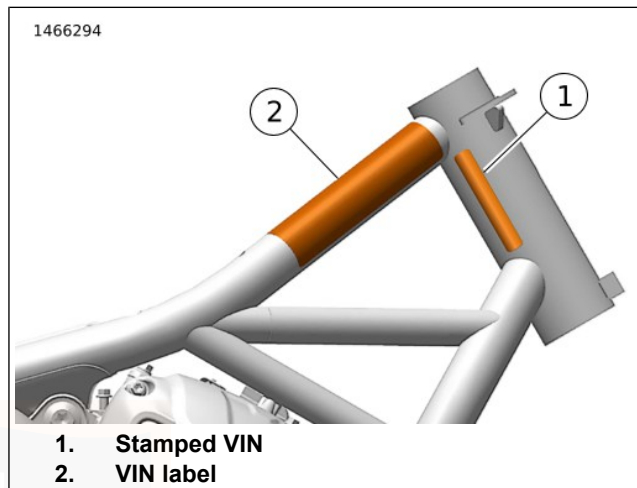

Figure 2. VIN Locations

1455304

1 2 3 4 5 6 7 8 9

1HD 1 ZD S 1 9 M B 600041

Figure 3. Typical Harley-Davidson VIN: 2021 Harley-Davidson Pan America Models

Table 7. Harley-Davidson VIN Breakdown: 2021 Pan America Models

POSITION	DESCRIPTION	POSSIBLE VALUES
1	World manufacturer identifier	1HD=Originally manufactured in the United States 5HD=Originally manufactured in the United States or Thailand for sale outside of the United States 932=Originally manufactured in Brazil MEG=Originally manufactured in India MLY=Originally manufactured in Thailand
2	Motorcycle type	1=Heavyweight motorcycle (901 cm ³ or larger)
3	Model	See VIN model table
4	Engine type	S=Revolution Max™ 1250 cm ³ liquid-cooled, fuel-injected

Table 7. Harley-Davidson VIN Breakdown: 2021 Pan America Models

POSITION	DESCRIPTION	POSSIBLE VALUES
5	Calibration/configuration, introduction	1=Domestic (DOM) 2=California (CAL) 3=Canada (CAN) 4=ENG/EN2/HDI/HD2/HD4 5=Japan (JPN) 6=Australia (AUS) 7=Brazil (BRZ) 8=Asia Pacific (APC) 9=IND/IN2 0=ASEAN (AZN) A=China (CHN) G=HD3
6	VIN check digit	Can be 0-9 or X
7	Model year	M=2021
8	Assembly plant	B=York, PA U.S.A. D=H-D Brazil-Manaus, Brazil (CKD) N=Haryana India (Bawal District Rewari) S=Tasit, Pluagdang, Rayong, Thailand
9	Sequential number	Varies

Table 8. VIN Model Codes: Pan America Models

CODE	MODEL	CODE	MODEL
ZD	RA1250 Pan America™	ZE	RA1250S Pan America® Special

MODELS AND FEATURES

Some models, features or configurations shown in this manual may not be available in all markets.

PRIMARY CONTROLS AND SERVICE COMPONENTS

Familiarize yourself with the location of all the controls and service components on your motorcycle.

NOTE

Illustrations are for general reference only. Controls and service components shown are general locations and

representations that do not show a specific model of motorcycle.

Harley-Davidson reserves the right to change specifications, equipment or designs at any time without notice and without incurring obligation.

See Figure 4 for rider controls and service components accessible when seated.

See Figure 5 for rider controls and service components accessible from the right.

See Figure 6 for rider controls and service components accessible from the left.

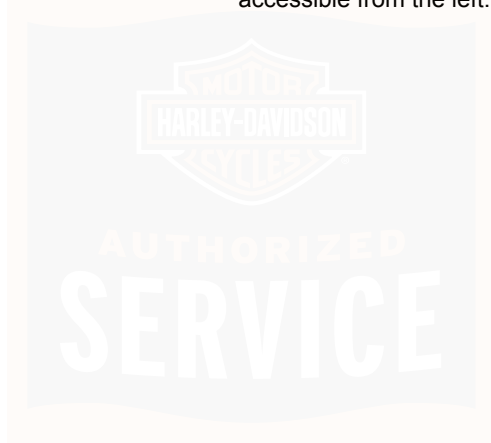

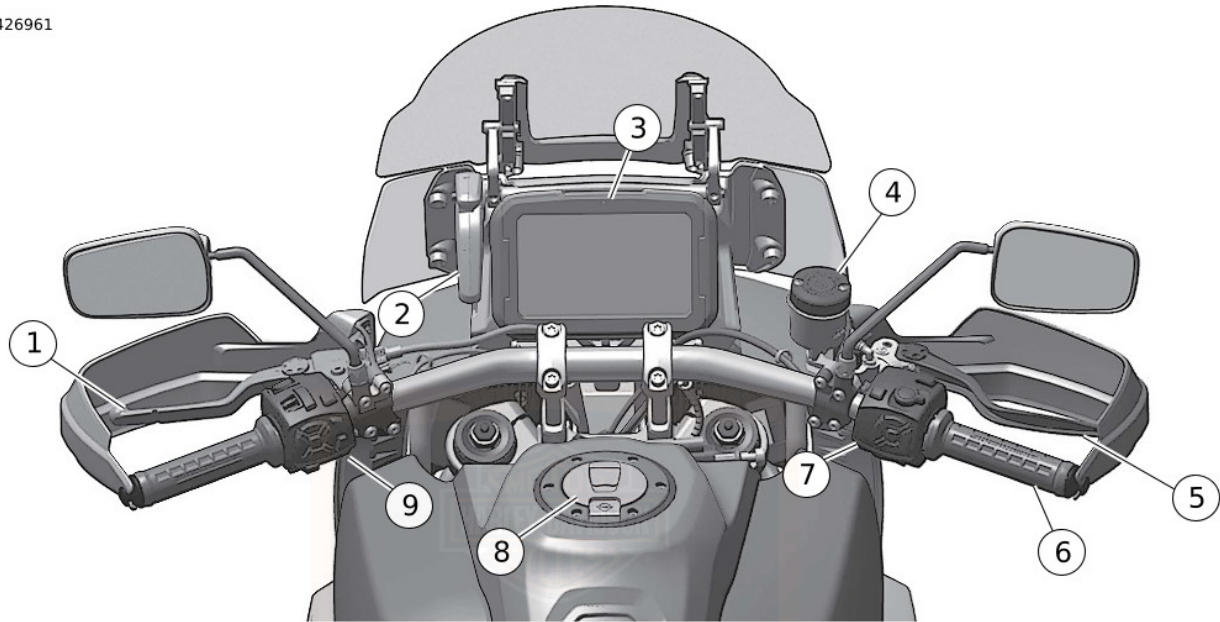

- | | |
|--------------------------------|------------------------------|
| 1. Clutch hand lever | 6. Throttle twist grip |
| 2. Windshield adjustment lever | 7. Right hand control module |
| 3. Instrument Module (IM) | 8. Fuel filler door |
| 4. Front brake fluid reservoir | 9. Left hand control module |
| 5. Front brake lever | |

Figure 4. Controls and Service Components (Typical)

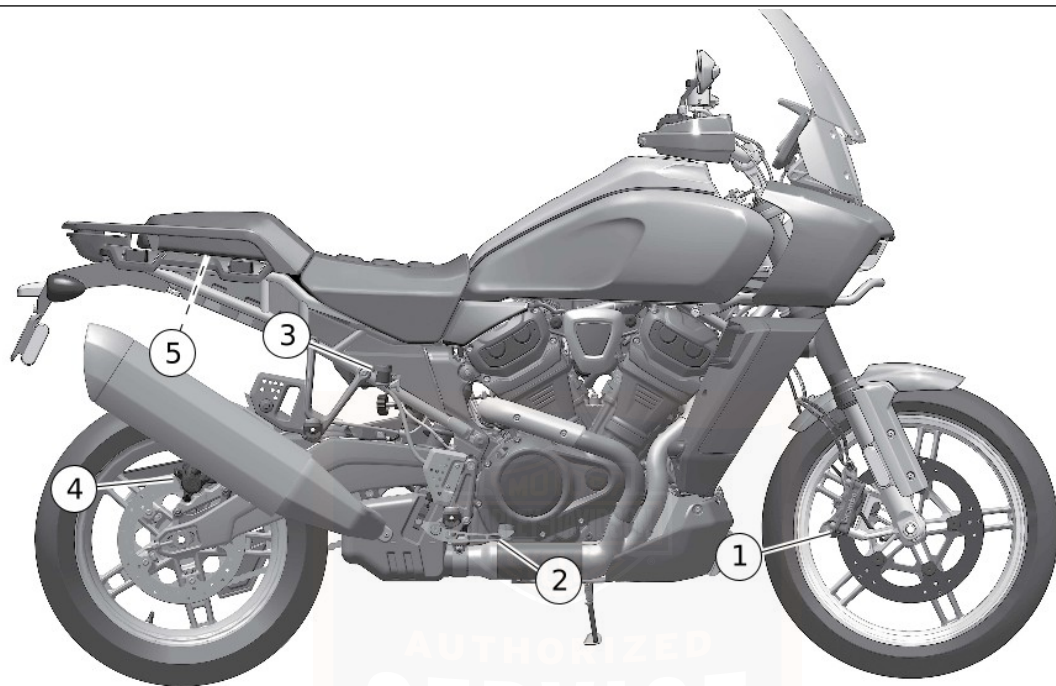

- | | |
|-------------------------------|--------------------------|
| 1. Front brake caliper | 4. Rear brake caliper |
| 2. Rear brake pedal | 5. Tool kit (under seat) |
| 3. Rear brake fluid reservoir | |

Figure 5. Controls and Service Components (typical)

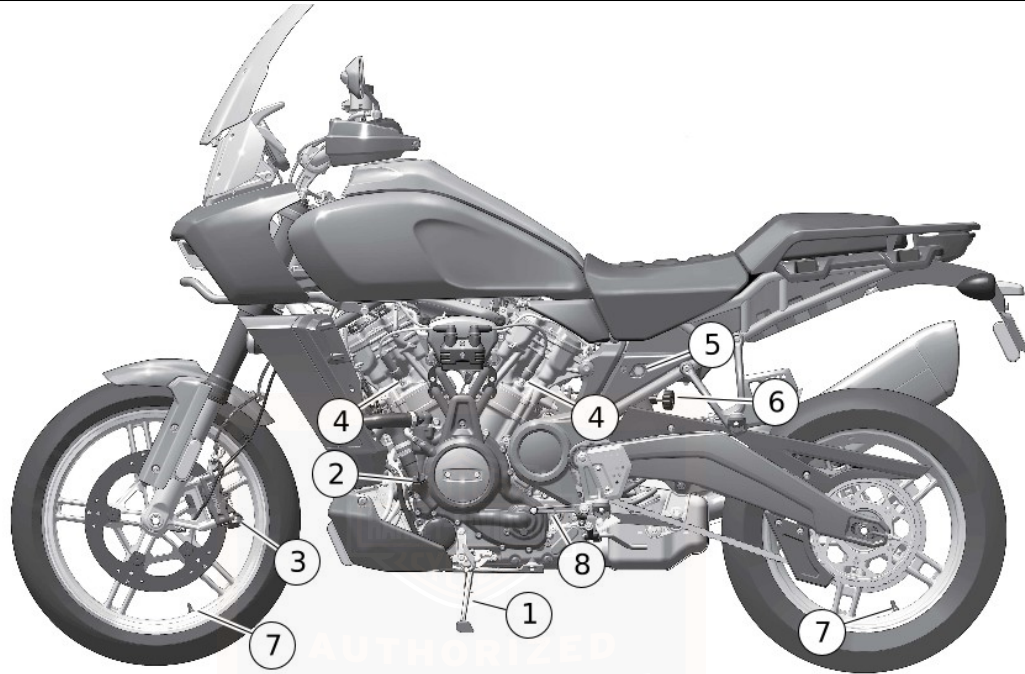

1. Jiffy stand
2. Oil filler cap/dipstick
3. Front brake caliper
4. Spark plug

5. Seat latch
6. Rear suspension adjuster (manual adjust)
7. Air pressure valve
8. Gear shift lever

Figure 6. Controls and Service Components (typical)

NOTES



SPECIFICATIONS

NOTE

- *Specifications in this publication may not match those of official certification in some markets due to timing of publication printing, variance in testing methods, and/or motorcycle differences. Customers seeking officially recognized regulatory specifications for their motorcycle should refer to certification documents and/or contact their respective dealer or distributor.*
- *Harley-Davidson reserves the right to change specifications, equipment or designs at any time without notice and without incurring obligation.*

Tires

▲ WARNING

Harley-Davidson recommends the use of its specified tires. Harley-Davidson vehicles are not designed for operation with non-specified tires, including snow, moped and other special-use tires. Use of non-specified tires can adversely affect stability, handling or braking and lead to loss of vehicle control, which could result in death or serious injury. (00024d)

Table 9. Specified Tires

MODEL	MOUNT	SIZE	SPECIFIED TIRE	PRESSURE COLD	
				psi	kPa
RA1250 Pan America™ RA1250S Pan America™ Special	Front	19 in	Michelin® Scorcher® Adventure 120/70R19 60V	36 psi	248 kPa
RA1250 Pan America™ RA1250S Pan America™ Special	Rear	17 in	Michelin® Scorcher® Adventure 170/60R17 72V	42 psi	290 kPa

Weights and Dimensions

Table 10. Weights

ITEM	Pan America™ (RA1250)		Pan America™ Special (RA1250S)	
	lb	kg	lb	kg
Running weight ⁽¹⁾	534	242	559	254
Maximum added weight allowed ⁽²⁾	469	213	444	201
GVWR	1003	455	1003	455
GAWR front	399	181	399	181
GAWR rear	665	302	665	302
<i>(1) The total weight of the motorcycle as delivered with all oil/fluids and approximately 90% of fuel.</i>				
<i>(2) The total weight of accessories, cargo, riding gear, passenger and rider must not exceed this weight.</i>				

Table 11. Dimensions

ITEM	Pan America™ (RA1250)		Pan America™ Special (RA1250S)	
	in	mm	in	mm
Length	89.2	2265	89.2	2265
Overall Width	38	965	38	965
Overall height	59.4	1510	59.4	1510
Wheel base	62.2	1580	62.2	1580
Road clearance	8.3	210	6.9	175
Seat height ⁽¹⁾	32.9	836	32.9	836
<i>(1) With 81.7 kg (180 lb) rider on seat</i>				

Capacities

Table 12. Capacities

ITEM	U.S.	METRIC
Fuel tank (total)	5.6 gal	21.2 L
Low fuel warning light on (approximate)	1.0 gal	3.8 L
Engine oil capacity	4.75 qt	4.5 L
Service oil change capacity	4.0 qt	3.8 L
Coolant (approximate)	2.32 qt	2.2 L

Engine and Transmission

Table 13. Engine

ITEM	SPECIFICATION	
Number of cylinders	2	
Type	4-cycle, 60 degree V-Type, Liquid cooled Dual over head camshafts (DOHC)	
Compression ratio	13.0:1	
Bore	105 mm	4.13 in
Stroke	72.3 mm	2.85 in

Table 13. Engine

ITEM	SPECIFICATION	
Displacement	1252 cm ³	76.3 in ³
Maximum Revolutions Per Minute (rpm)	9500 rpm ⁽¹⁾	
Fuel requirement	Premium unleaded	
Lubrication system	Pressurized, semi-dry sump	

(1) Maximum rpm is limited until engine reaches full operating temperature, when transmission is in neutral with clutch lever released and when maximum rpm is held for more than 3 seconds.

Table 14. Transmission

TRANSMISSION	SPECIFICATION
Type	Constant mesh, foot shift
Speeds	6 forward

Electrical

Table 15. Electrical

ITEM	SPECIFICATION
Ignition timing	Not adjustable
Battery	12 V, 12 Ah, 225 CCA sealed and maintenance free
Charging system	45 A maximum output

NOTES



REMOVING MOTORCYCLE FROM STORAGE

1. Charge and install the battery. See SERVICE PROCEDURES > BATTERY MAINTENANCE (Page 157).
2. Inspect drive chain and sprocket. See MAINTENANCE AND LUBRICATION > CHECK DRIVE CHAIN AND SPROCKETS (Page 148).
3. Perform the items in the BEFORE RIDING > PRE-RIDE CHECKLIST (Page 33).

PRE-RIDE CHECKLIST

1. Check the amount of fuel in the tank. Add fuel if required. See BEFORE RIDING > FILLING THE FUEL TANK (Page 35).
2. Adjust mirrors to proper riding positions. See BEFORE RIDING > ADJUSTING MIRRORS (Page 44).
3. Check the engine oil level. See MAINTENANCE AND LUBRICATION > CHECK ENGINE OIL LEVEL (Page 138).
4. Check coolant level. See MAINTENANCE AND LUBRICATION > COOLANT (Page 152).

5. Check brake fluid level. See MAINTENANCE AND LUBRICATION > CHECKING BRAKE FLUID LEVEL AND CHANGING BRAKE FLUID (Page 145).
6. Inspect brake pads and discs for wear. See MAINTENANCE AND LUBRICATION > INSPECTING BRAKE PADS AND DISCS (Page 143).
7. Check the hand and foot controls to be sure they are operating properly. Operate the front and rear brakes, throttle, clutch and shifter. See OWNER MANUAL > OPERATION (Page 71).
8. Inspect brake lines for wear or damage.
9. Check steering for smoothness by turning the handlebar through the full operating range.

⚠ WARNING

Be sure tires are properly inflated, balanced, undamaged, and have adequate tread. Inspect your tires regularly and see a Harley-Davidson dealer for replacements. Riding with excessively worn, unbalanced, improperly inflated, overloaded or damaged tires can lead to tire failure and adversely affect stability and handling, which could result in death or serious injury. (00014b)

10. Check tire condition, pressure and motorcycle loading. Refer to BEFORE RIDING > CHECKING TIRE PRESSURE AND INSPECTING TIRES (Page 39) for correct tire inflation pressure and motorcycle weight allowances.
11. Check suspension front and rear pre-load settings. Adjust to motorcycle loading, if necessary. Refer to BEFORE RIDING > SUSPENSION ADJUSTMENTS (Page 46), BEFORE RIDING > ELECTRONIC SUSPENSION (Page 49) and BEFORE RIDING > MANUAL SUSPENSION (Page 51).
12. Check for any fuel, oil or hydraulic fluid leaks.
13. Check drive chain for wear or damage.

▲ WARNING

Be sure headlamp, tail and stop lamp and turn signals are operating properly before riding. Poor visibility of rider to other motorists can result in death or serious injury. (00478b)

14. Check all electrical equipment and switches including the stop lamp, turn signals and horn for proper operation.

15. Service your motorcycle as necessary.

BREAK-IN RIDING RULES

The First 500 Miles (800 Kilometers)

The sound design, quality materials, and workmanship that are built into your new Harley-Davidson will give you optimum performance right from the start.

To allow your engine to wear-in its critical parts, we recommend that you observe the riding rules provided below for the first 805 km (500 mi).

1. During the first 80 km (50 mi) of riding, keep the engine speed below 5000 rpm in any gear. Do not lug the engine by running or accelerating at very low rpm, or by running at high rpm longer than needed for shifting or passing.
2. Up to 805 km (500 mi), vary the engine speed and avoid operating at any steady engine speed for long periods. Engine speed up to 7000 rpm in any gear is permissible.
3. Drive slowly and avoid fast starts at wide open throttle until the engine has warmed up.
4. Avoid lugging the engine by not running the engine at very low speeds in higher gears.
5. Avoid hard braking. Break-in new brakes with moderate use for the first 161 km (100 mi).

FILLING THE FUEL TANK

See SAFETY FIRST > SAFE OPERATING RULES (Page 3) and review the following safety alerts.

⚠ WARNING

Avoid spills. Slowly open fuel filler cap. Do not fill above bottom of filler neck insert, leaving air space for fuel expansion. Secure filler cap after refueling. Gasoline is extremely flammable and highly explosive, which could result in death or serious injury. (00028b)

⚠ WARNING

Use care when refueling. Pressurized air in fuel tank can force gasoline to escape through filler tube. Gasoline is extremely flammable and highly explosive, which could result in death or serious injury. (00029a)

⚠ WARNING

Do not store motorcycle with gasoline in tank within the home or garage where open flames, pilot lights, sparks or electric motors are present. Gasoline is extremely flammable and highly explosive, which could result in death or serious injury. (00003a)

⚠ WARNING

Do not use aftermarket fuel caps. Aftermarket fuel caps may fit improperly and leak, which could lead to death or serious injury. See a Harley-Davidson dealer for approved fuel caps. (00034a)

NOTICE

Do not spill fuel onto the motorcycle while refueling. Immediately wipe up fuel spills on your motorcycle. Fuel can cause damage to cosmetic surfaces. (00147b)

NOTICE

Use only unleaded fuel in catalytic converter-equipped motorcycles. Using leaded fuel will damage the emission control system. (00150c)

Modern service station pumps dispense a high flow of gasoline into a motorcycle fuel tank. This can cause air entrapment and pressurization.

FUEL FILLER CAP

Open

See Figure 7. Lift fuel filler cap latch (2) to open filler cap (1).

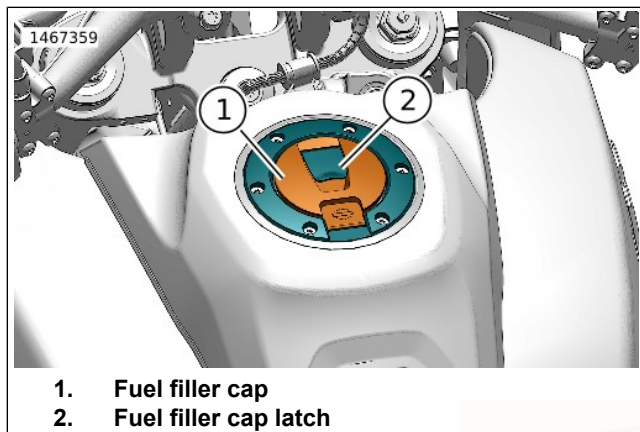

Figure 7. Fuel Tank

Filling

See Figure 8. Do not overfill the fuel tank. Fully insert the pump nozzle into the filler hole. Do not fill the tank beyond the bottom of the filler neck. A warm engine, the sun or extreme temperatures can cause the fuel to expand. Fuel can spill out of the tank and damage the finish. See SAFETY FIRST > SAFE OPERATING RULES (Page 3).

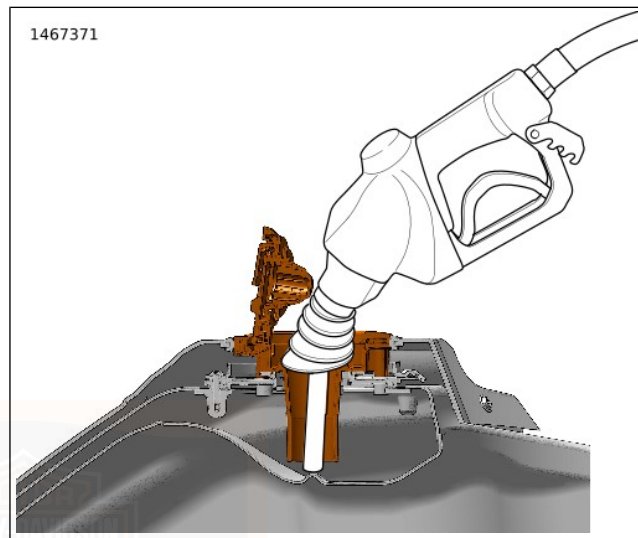

Figure 8. Fuel Level below Filler Neck

Close

Close filler cap, push cap down firmly until latch clicks.

FUEL SYSTEM INFORMATION

Gasoline

Your motorcycle was designed to get the best performance and efficiency using unleaded gasoline. Most gasoline is blended with alcohol and/or ether to create oxygenated blends. The type and amount of alcohol or ether added to the fuel is important.

NOTICE

Do not use gasoline that contains methanol. Doing so can result in fuel system component failure, engine damage and/or equipment malfunction. (00148a)

NOTICE

Use only unleaded fuel in catalytic converter-equipped motorcycles. Using leaded fuel will damage the emission control system. (00150c)



- ETHANOL fuel is a mixture of ethanol (grain alcohol) and unleaded gasoline and can have an impact on fuel mileage.
- REFORMULATED OR OXYGENATED GASOLINES (RFG) describes gasoline blends that are specifically designed to burn cleaner than other types of gasoline. This results in fewer tailpipe emissions. They are also formulated to reduce evaporative losses to the environment. Reformulated gasolines use additives to oxygenate the gas. Your motorcycle will run normally using this type of fuel. Harley-Davidson recommends using it whenever possible as an aid to cleaner air in our environment.
- Some gasoline blends might adversely affect starting, driveability or fuel efficiency. If any of these problems are experienced, try a different brand of gasoline or gasoline with a higher octane blend.

Table 16. Octane Rating

SPECIFICATION	RATING
Pump Octane (R+M)/2	91 (95 RON)

AUTHORIZED
SERVICE

Table 17. Fuel Specification

Common Identifier	Specification	Rating
MTBE	Methyl Tertiary Butyl Ether	Gasoline/Methyl Tertiary Butyl Ether (MTBE) blends are a mixture of gasoline and as much as 15% MTBE. Gasoline/MTBE blends use in your motorcycle is approved.
Methanol	Methanol or Racing Fuel	Do not use racing fuel or fuel containing methanol; use of these fuels will damage the fuel system.
	5% Ethanol	Fuels with an ethanol content of up to 5% (E5) may be used in your motorcycle without affecting vehicle performance.
	10% Ethanol	Fuels with an ethanol content of up to 10% (E10) may be used in your motorcycle without affecting vehicle performance. United States customers: The United States' Clean Air Act prohibits the use of gasoline blends containing greater than 10% ethanol in motorcycles.
	22% Ethanol	Fuel in the Brazilian market has ethanol content which ranges from 21–27.5%. Harley-Davidson Motorcycles configured for Brazil are equipped with engine control calibrations developed to work properly with these fuels. Use of fuels with high ethanol content in Harley-Davidson motorcycles intended for other regulatory markets may result in poor drivability, setting of the check engine light and potential engine damage.
	85% Ethanol	Do not use fuel containing 85% ethanol. Use of these fuels will damage the fuel system and may lead to engine damage.

Catalytic Converter

Vehicles in some markets are equipped with catalytic converters.

NOTICE

Do not operate catalytic converter-equipped vehicle with engine misfire. If you operate the vehicle under this condition, the exhaust will become abnormally hot, which can cause vehicle damage, including emission control loss. (00149c)

ABS BRAKE SYSTEM IDENTIFICATION

Identification

See Figure 9. Models with ABS can be identified by a Wheel Speed Sensor (WSS) on the left side of the front wheel.

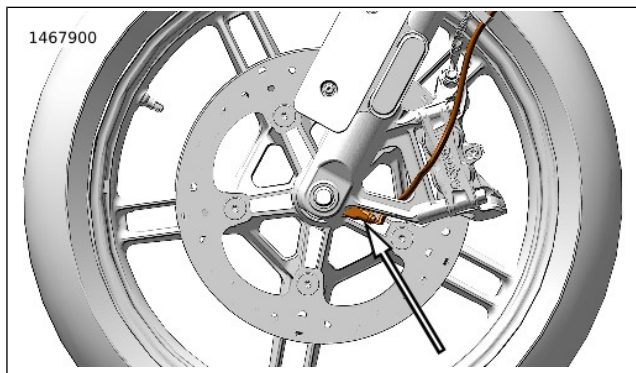

Figure 9. Wheel Speed Sensor (ABS identification)

CHECKING TIRE PRESSURE AND INSPECTING TIRES

General Information

⚠ WARNING

Match tires, tubes, rim strips or seals, air valves and caps to the correct wheel. Contact a Harley-Davidson dealer. Mismatching can lead to tire damage, allow tire slippage on the wheel or cause tire failure, which could result in death or serious injury. (00023c)

⚠ WARNING

Harley-Davidson front and rear tires are not the same. Interchanging front and rear tires can cause tire failure, which could result in death or serious injury. (00026a)

Tire Pressure

⚠ WARNING

Be sure tires are properly inflated, balanced, undamaged, and have adequate tread. Inspect your tires regularly and see a Harley-Davidson dealer for replacements. Riding with excessively worn, unbalanced, improperly inflated, overloaded or damaged tires can lead to tire failure and adversely affect stability and handling, which could result in death or serious injury. (00014b)

Tire pressures should be set using information in Table 18 and Table 19. Tires are considered Cold Tires if the vehicle has not been recently ridden. The tire pressure increases as the tire warms. Tires can warm due to both riding and high ambient air temperatures. Tires can remain warm for up to 2 hours after riding. For the most accurate reading, check tire pressures with a good gauge before riding while the tires are cold.

Check tire pressure:

- As part of the pre-ride checklist.
- At every scheduled service interval.

For Cold Tires with an Ambient Air Temp of 20 °C (68 °F) or less: Table 18

Table 18. Specified Tires

MODEL	MOUNT	SIZE	SPECIFIED TIRE	PRESSURE COLD	
				psi	kPa
RA1250 Pan America™ RA1250S Pan America™ Special	Front	19 in	Michelin® Scorcher® Adventure 120/70R19 60V	36 psi	248 kPa
RA1250 Pan America™ RA1250S Pan America™ Special	Rear	17 in	Michelin® Scorcher® Adventure 170/60R17 72V	42 psi	290 kPa

For Cold Tires with an Ambient Air Temp higher than 20 °C (68 °F): Refer to the first column in Table 19 to determine the tire pressure adjustments. For example: If the motorcycle has not been ridden for 2 hours or more and the ambient temperature is 31 °C (88 °F), the recommended front and rear pressures are Table 18 pressures plus 14 kPa (2 psi).

Tires warm due to riding which increases the tire pressure. If the vehicle has been recently ridden, refer to the second column in Table 19 to determine the tire pressure adjustment. For example: If the motorcycle has been recently ridden and

the ambient temperature is 31 °C (88 °F), the recommended front and rear pressures are the Table 18 pressures plus 48 kPa (7 psi).

If a tire pressure adjustment is made when the vehicle has been recently ridden, re-adjust the tire pressure per recommendations when the tires have cooled. Tires can remain warm for up to 2 hours after riding.

Harley-Davidson does not perform any testing with only nitrogen in tires. Harley-Davidson neither recommends nor discourages the use of pure nitrogen to inflate tires.

Table 19. Tire Pressure Adjustment

AMBIENT AIR TEMPERATURE	MOTORCYCLE NOT RIDDEN FOR 2 HOURS OR MORE: ADD TO FRONT AND REAR PRESSURES IN SPECIFIED TIRES TABLE	MOTORCYCLE RECENTLY RIDDEN: ADD TO FRONT AND REAR PRESSURES IN SPECIFIED TIRES TABLE
20 °C (68 °F) or less	0 kPa (0 psi)	34 kPa (5 psi)
26 °C (79 °F)	7 kPa (1 psi)	41 kPa (6 psi)
31 °C (88 °F)	14 kPa (2 psi)	48 kPa (7 psi)
37 °C (99 °F)	21 kPa (3 psi)	55 kPa (8 psi)
42 °C (108 °F) or higher	28 kPa (4 psi)	62 kPa (9 psi)

Inspecting Tires

⚠ WARNING

Replace tire immediately with a Harley-Davidson specified tire when wear bars become visible or only 1 mm (1/32 in) tread depth remains. Riding with a worn tire could result in death or serious injury. (00090c)

Check tire tread:

- As part of the pre-ride checklist.
 - At every scheduled service interval.
1. Inspect each tire for punctures, cuts and breaks.

Harley-Davidson tires are equipped with wear bars that run horizontally across the tread.

A tire is considered worn when the wear bars are visible or if only 0.8 mm (0.031 in) tread depth remains. A worn tire can:

- Be more easily damaged leading to tire failure.
- Provide reduced traction.
- Adversely affect stability and handling.

See Figure 10. Always replace tires before the tread wear bars appear.

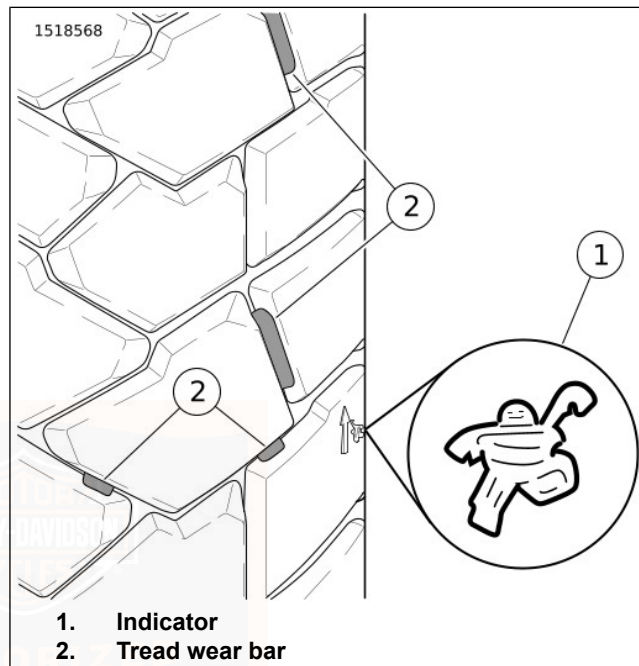

Figure 10. Tread Wear Indicator: Michelin Tires

Replacing Tires

⚠ WARNING

Tires are a critical safety component. Contact a Harley-Davidson dealer for tire repair or replacement. Improper tire service can adversely affect stability and handling, which could result in death or serious injury. (00057a)

⚠ WARNING

Harley-Davidson recommends the use of its specified tires. Harley-Davidson vehicles are not designed for operation with non-specified tires, including snow, moped and other special-use tires. Use of non-specified tires can adversely affect stability, handling or braking and lead to loss of vehicle control, which could result in death or serious injury. (00024d)

⚠ WARNING

Only install original equipment tire valves and valve caps. A valve, or valve and cap combination, that is too long or too heavy can strike adjacent components and damage the valve, causing rapid tire deflation. Rapid tire deflation can cause loss of vehicle control, which could result in death or serious injury. (00281a)

⚠ WARNING

Replace punctured or damaged tires. In some cases, small punctures in the tread area may be repaired from within the removed tire by a Harley-Davidson dealer. Speed should NOT exceed 80 km/h (50 mph) for the first 24 hours after repair, and the repaired tire should NEVER be used over 129 km/h (80 mph). Failure to follow this warning could lead to tire failure and result in death or serious injury. (00015b)

⚠ WARNING

Replace tire immediately with a Harley-Davidson specified tire when wear bars become visible or only 1 mm (1/32 in) tread depth remains. Riding with a worn tire could result in death or serious injury. (00090c)

New tires are needed if any of the following conditions exist (refer to Table 18 for the specified replacement tires):

- Tread wear bars become visible on the tread surfaces.
- Tire cords or fabric become visible through cracked sidewalls, snags or deep cuts.
- Bumps, bulges or slits in the tire.
- Punctures, cuts, or other damage to the tire that cannot be repaired.

When installing tires on rims, do not rely on tread design to determine direction of rotation. Always be sure the rotational arrows molded into the sidewalls point in the direction of rotation when the vehicle is moving forward.

ADJUSTING MIRRORS

⚠ WARNING

Objects in mirrors are closer than they appear. Use caution when judging distance of objects in mirrors. Failure to judge correct distances could result in death or serious injury. (00033a)

Adjust mirrors so you can see a small portion of your shoulders in each mirror. This will help you establish the relative distance of vehicles to the rear of your motorcycle.

OPERATING JIFFY STAND

Location

⚠ WARNING

Always park motorcycle on a level, firm surface. An unbalanced motorcycle can fall over, which could result in death or serious injury. (00039a)

⚠ WARNING

The jiffy stand locks when placed in the full forward (down) position with vehicle weight on it. If the jiffy stand is not in the full forward (down) position with vehicle weight on it, the vehicle can fall over which could result in death or serious injury. (00006a)

⚠ WARNING

Be sure jiffy stand is fully retracted before riding. If jiffy stand is not fully retracted, it can contact the road surface causing a loss of vehicle control, which could result in death or serious injury. (00007a)

NOTE

When parking your motorcycle on a grade, place the transmission in gear after turning off the engine.

See Figure 6. The jiffy stand is located on the left side of the motorcycle.

Jiffy Stand Switch (If equipped)

On models equipped with the jiffy stand interlock switch, the motorcycle will start and run with the jiffy stand down while the transmission is in neutral. If the jiffy stand is down and the transmission in gear, engaging the clutch stalls the

motorcycle. Raising the jiffy stand or putting the transmission in neutral will permit the engine to run.

While the motorcycle is in motion at speeds greater than 15km/h (10mph), lowering the jiffy stand will not stop the engine.

OPERATING CENTER STAND

▲ WARNING

Always park motorcycle on a level, firm surface. An unbalanced motorcycle can fall over, which could result in death or serious injury. (00039a)

Using Center Stand

1. Place transmission in neutral.
2. Grasp left hand grip and side of motorcycle near seat.
3. Stand motorcycle upright off jiffy stand.
4. See Figure 11. Press down on lever (2) with foot.
5. Ensure feet (3) are both on ground.

6. While pressing down on lever (2) rock motorcycle to the rear lifting motorcycle onto center stand (1).

Storing Center Stand

NOTE

Lower jiffy stand and place motorcycle in gear before storing center stand.

1. Grasp left hand grip and side of motorcycle near seat.
2. Rock motorcycle to rear causing rear tire to touch the ground.
3. Push motorcycle toward front tire rocking it off the center stand.
4. Lean motorcycle onto jiffy stand.

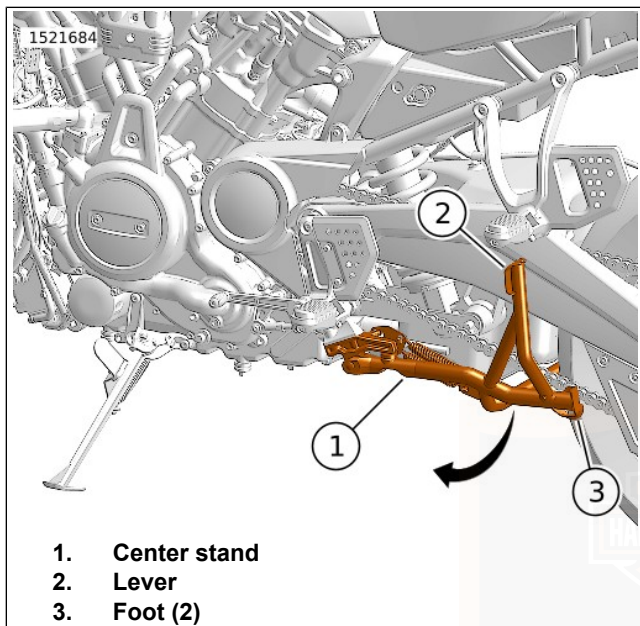

Figure 11. Center Stand

SUSPENSION ADJUSTMENTS

Suspension Identification

See Figure 12.

Manual suspension: (1) Models equipped with manual suspension have mechanical adjusters at the top of each fork.

Semi-active suspension: (2) Models equipped with semi-active suspension have wires coming out of the top of left side fork assembly.

ARH (w/Semi-active suspension): (3) Models equipped with ARH (w/Semi-active suspension) have wires coming out of the top of both left and right fork assemblies.

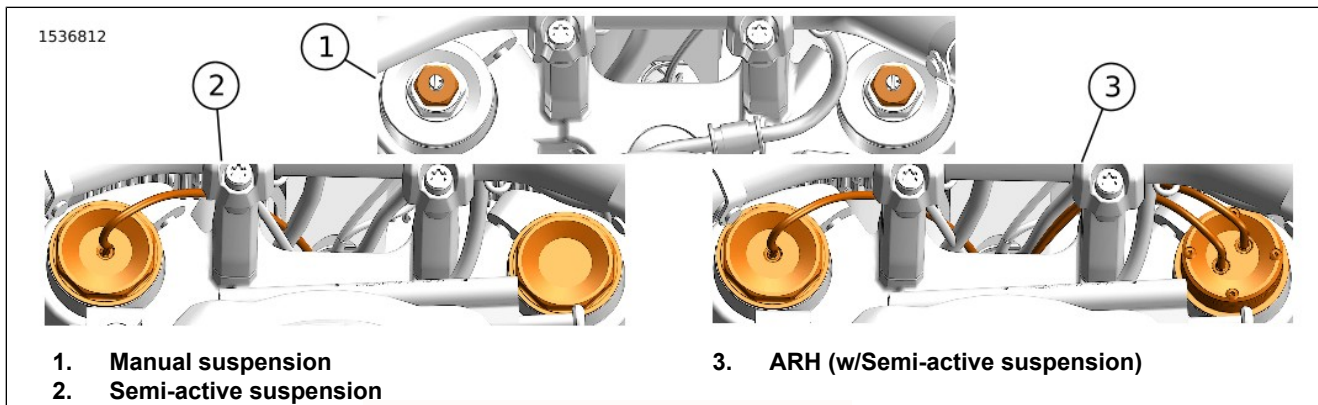

Figure 12. Front Suspensions

Suspension Definitions

Damping is set at the factory for the average solo rider under normal riding conditions. The rider may make adjustments to compensate for individual riding styles and varying road conditions.

Evaluating and changing the rebound and compression damping is a very subjective process with many variables and should be approached carefully.

Damping: Resistance to velocity of suspension movement. Damping affects how easily the suspension can move and limits oscillations of the system once movement has begun.

Compression: The suspension is compressed when the wheel moves upward (when riding over a bump).

Rebound: The suspension is rebounding when it is moving back from being compressed (rebounding to the road surface after a bump).

Preload: An adjustment made to the rear shock and front fork springs to limit vehicle and rider sag to a standard percentage of total suspension travel.

Suspension Tuning

Make all suspension adjustments in small increments. Radical setting changes may cause you to skip the best adjustment.

Refer to Table 20. Possible suspension and operating characteristics and their probable causes are listed. This table

is helpful in keeping your motorcycle in good operating condition.

To achieve the proper settings you will need the preload properly adjusted, the tires properly inflated and a familiar bumpy road. It is useful if the road contains a variety of different kinds of bumps from small sharp bumps such as potholes or frost heaves to large cracks.

Table 20. Suspension Tuning

SUSPENSION CHARACTERISTICS	SOLUTION
Bike wallows through turns.	Increase rebound damping.
Bike feels loose or vague after bumps.	
Wheel tends to "pogo" or suffer continuous bouncing after passing a bump. This is often noticeable by watching the bike as it travels over bumps.	
Wheel responds to bump but doesn't return to ground quickly after bumps. This is more pronounced over a series of bumps and is often referred to as "packing down."	Reduce rebound damping.
Bike bottoms in dips or while cornering.	Increase compression damping.
Bike has excessive brake dive.	
Harsh ride, particularly over washboard surfaces.	Reduce compression damping.
Bumps transfer through handlebars or seat.	
Suspension seems not to respond to bumps. Tires chatter through corners or rider is jolted over rough roads.	

Changes in Load

The front and rear preload setting will need to be adjusted for the rider's weight and cargo. This adjustment should be made

before the motorcycle is ridden any distance and after changing the overall vehicle weight (adding saddlebags, etc.).

Changes in the load carried requires changes in the preload settings. Carrying less weight than was used for setting up

the suspension requires decreasing the amount of preload. Increasing the load carried requires adding more preload.

ELECTRONIC SUSPENSION

For manual suspension adjustment Refer to: BEFORE RIDING > MANUAL SUSPENSION (Page 51).

Enhanced Semi-active Suspension

Models equipped with enhanced semi-active suspension have wires coming out of the top of both left and right fork assemblies. See Figure 12. Adaptive Ride Height (ARH) allows for a lower seat height when not moving without sacrificing ride quality. If desired the system can also be locked out, keeping the motorcycle at ride height. See Figure 13.

Lower Seat Height (Auto)

In this configuration, the ARH system lowers the suspension of the motorcycle while stopped. Once the vehicle begins to move, the ARH system will automatically “pump up” the suspension to the correct ride height setting for optimum performance. It is an automatic lowering system that does not have the drawback of reduced travel. Used where lower seat height at a stop is desired compared to non-ARH models.

How rider will experience ARH:

- Power on/bike at rest = ARH drops motorcycle to lowest setting. Vehicle will be in this state from previous ride.
- Bike moving = ARH pumps up suspension to optimum ride height. Est time to ride height 10-30 sec depending on road roughness. ARH uses suspension stroke to pump preload mechanism.
- Power off/power failure = ARH defaults to pump up state, meaning any further suspension travel will pump up suspension. Could be possible to pump up suspension to ride height while vehicle is being trailered.

Auto When Auto is selected the suspension will lower while coming to a complete stop.

Auto with Short Delay When Auto with Short Delay is selected the suspension will lower approximately 0.5 seconds after coming to a complete stop.

Auto with Long Delay When Auto with Long Delay is selected the suspension will lower approximately 2 seconds after coming to a complete stop.

Lock at Ride Height

When Lock at Ride Height is selected ARH is locked and suspension will not lower when vehicle slows to a stop.



Figure 13. ARH Selections

Semi-Active Suspension

Models equipped with semi-active suspension have wires coming out of the top of left side fork assembly. See Figure 12.

Semi-active Suspension Summary: A Semi-Active suspension system uses electronically controlled valves to make damping changes in the 10 millisecond timeframe. Semi-Active systems actively adjust damping forces according to real time data collected from the vehicle and the ride mode setting to create the best suspension performance output at that specific moment in time.

Gives the ability to have comfort, control, and adapt to a variety of events that desire different settings by automatically adjusting the damping setting in a matter of milliseconds. Adjustments are made based on vertical motion, throttle application, wheel travel, braking lean angle, ride mode and vehicle speed end stop (either extreme of suspension travel).

How rider will experience Semi Active:

- No power = Damping defaults to “nominal” (average damping force).
- Power on, but engine off = Damping in soft state.
- Bike moving = Semi-Active systems actively adjust damping forces (anywhere from soft to firm) according to real time data and ride mode.

Adjusting Electronic Suspension

To access settings menu, see OPERATION > INSTRUMENTS (Page 75).

To adjust electronic suspension, navigate to vehicle loading menu. Settings> Ride Customization> Vehicle Loading. Select appropriate setting.



Figure 14. Suspension Selections

MANUAL SUSPENSION

Rear Shock

General

Damping is set at the factory for the average solo rider under normal riding conditions. The rider may make adjustments to compensate for load, individual riding styles and varying road conditions.

Evaluating and changing the rebound and compression damping is a subjective process with many variables and should be approached carefully.

NOTICE

Compression and rebound adjusting valves may be damaged if too much force is used at either end of the adjustment range. (00237a)

NOTE

Do not force adjusters beyond mechanical stops.

Rebound and Compression Damping

Rebound Damping Adjustment

1.

NOTE

*Rebound adjuster is marked as **TEN** on the shock absorber.*

See Figure 15. Use a flat blade screwdriver to turn rebound adjuster clockwise in the H (hard) direction until it stops. This is the maximum rebound damping setting.

2. Turn rebound adjuster counter-clockwise in the S (soft) direction the recommended number of turns. Refer to Table 23.

Compression Damping Adjustment

1. See Figure 16. Use a flat blade screwdriver to turn compression adjuster clockwise in the H (hard) direction until it stops. This is the maximum compression damping setting.
2. Turn compression adjuster counter-clockwise in the S (soft) direction the recommended number of turns. Refer to Table 23.

Preload Adjustment

1. See Figure 17. Rotate the preload adjuster knob clockwise in the HIGH direction to increase preload setting, or counterclockwise to decrease preload setting until desired setting is reached.
2. Calculate rear preload settings.
 - a. **Rider:** Refer to Table 21 for preload clicks required for rider. Note clicks required.
 - b. **Passenger or cargo:** Refer to Table 22 for additional preload clicks required for passenger or cargo. Note clicks required.

- c. Add rider and passenger/cargo preload amounts together to get final adjustment setting.
3. See Figure 17. Adjust preload adjuster knob to the desired number of clicks.

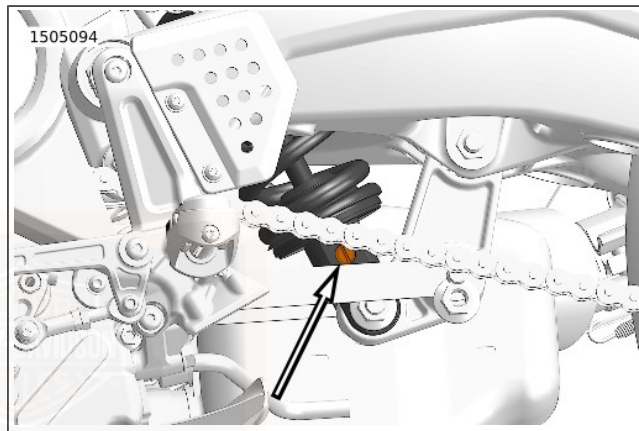

Figure 15. Rebound Adjuster

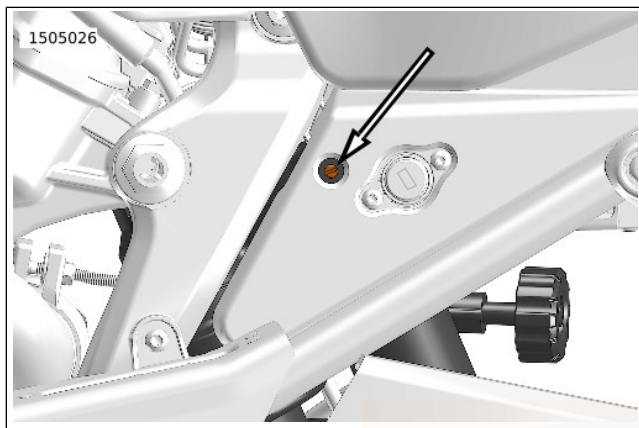

Figure 16. Compression Adjuster

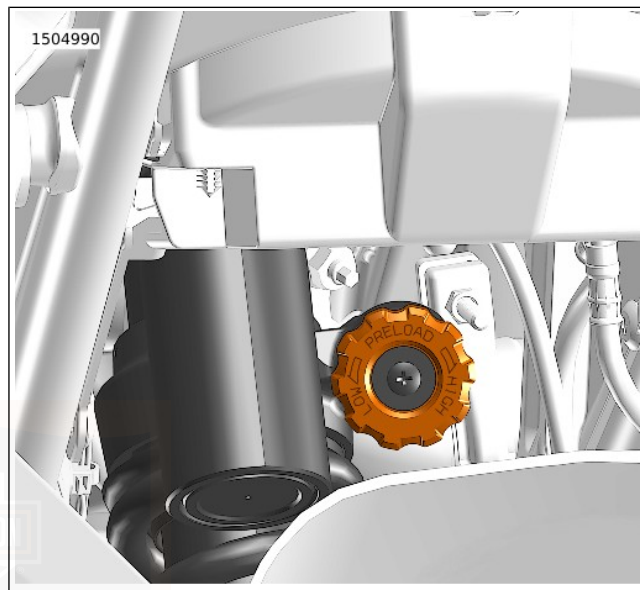

Figure 17. Preload Adjuster

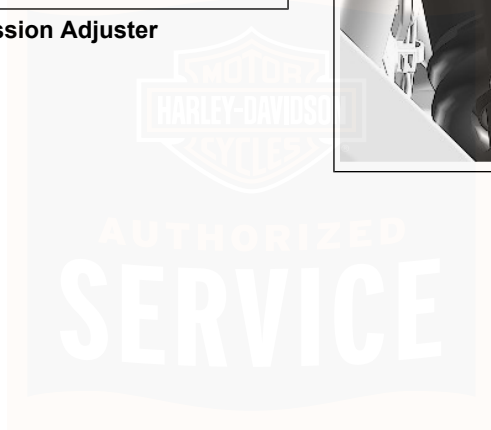

Table 21. Rear Preload Suspension Settings

RIDER WEIGHT	REAR SHOCK
kg/lb	Clicks from Minimum ⁽¹⁾
<68 kg (150 lb)	0
68–77 kg (150–170 lb)	0
77–86 kg (170–190 lb)	0
86–95 kg (190–210 lb)	7
95–104 kg (210–230 lb)	14
104–113 kg (230–250 lb)	20
113–122 kg (250–270 lb)	27
122–132 kg (270–290 lb)	34
132 kg (290 lb) to GVWR	34

(1) Minimum is defined as fully turned out counter-clockwise.

Table 22. Rear Preload with Passenger or Cargo

PASSENGER or CARGO	REAR SHOCK
kg/lb	Additional Clicks ⁽¹⁾
0–23 kg (0–50 lb)	+12
23–45 kg (50–100 lb)	+34
45–68 kg (100–150 lb)	+34
68 kg (150 lb) to GVWR	+34

(1) Add to preload setting for passenger or cargo weight.

Table 23. Rear Shock Compression and Rebound

RIDE SETTING	REAR SHOCK ⁽¹⁾	
	Compression	Rebound
Standard	1.5	1
Comfort	2.5	3
Sport	1	0.5

(1) Damping adjuster settings are done by turning adjuster clockwise until it stops at the maximum setting, then counting the clicks counter-clockwise to the desired setting.

Front Fork

General

Damping is set at the factory for the average solo rider under normal riding conditions. The rider may make adjustments to compensate for load, individual riding styles and varying road conditions.

Evaluating and changing the rebound and compression damping is a subjective process with many variables and should be approached carefully.

NOTICE

Compression and rebound adjusting valves may be damaged if too much force is used at either end of the adjustment range. (00237a)

NOTE

Do not force adjusters beyond mechanical stops.

Make identical adjustments to left and right shock absorbers.

Compression and Rebound Damping

Compression Damping Adjustment

See Figure 18. The compression adjuster (2) screw is located on the top of the right side fork tube.

1. Turn compression adjuster screw clockwise until it stops. This is the maximum compression damping setting.
2. Turn compression adjuster screw counter-clockwise the recommended number of turns. Table 26

Rebound Damping Adjustment

See Figure 18. The rebound adjuster (3) screw is located on the top of the left side fork tube.

1. Turn rebound adjuster screw clockwise until it stops. This is the maximum rebound damping setting.
2. Turn rebound adjuster screw counter-clockwise the recommended number of turns. Table 26

Spring Preload

See Figure 18. The preload adjuster (1) is located on the top of each fork tube.

1. Turn preload adjuster counter-clockwise until it stops. This is the minimum preload setting.
2. Calculate front preload settings.
 - a. **Rider:** Refer to Table 24 for required rider preload adjustment. Note required adjustment.
 - b. **Passenger or cargo:** Refer to Table 25 for required passenger and cargo preload. Note required adjustment.
 - c. Add rider and passenger/cargo preload amounts together to get final adjustment setting.
3. Adjust front preload settings. Turn preload adjuster clockwise the calculated number of turns.

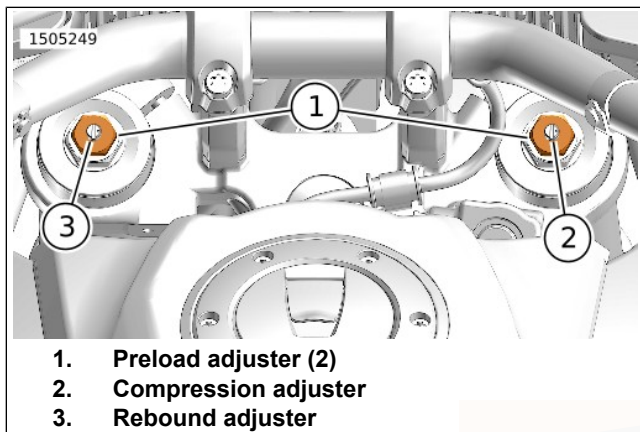

Figure 18. Front Suspension Adjusters

Table 24. Front Preload Suspension Settings

RIDER WEIGHT	FRONT FORKS
kg/lb	Turns from Minimum ⁽¹⁾
<68 kg (150 lb)	1
68–77 kg (150–170 lb)	2
77–86 kg (170–190 lb)	5
86–95 kg (190–210 lb)	8
95–104 kg (210–230 lb)	10
104–113 kg (230–250 lb)	13
113–122 kg (250–270 lb)	15
122–132 kg (270–290 lb)	15
132 kg (290 lb) to GVWR	15

(1) Number of clockwise turns from minimum preload setting.

Table 25. Front Preload with Passenger or Cargo

PASSENGER or CARGO	FRONT FORKS
kg/lb	Additional Turns ⁽¹⁾
0–23 kg (0–50 lb)	+0
23–45 kg (50–100 lb)	+1
45–68 kg (100–150 lb)	+2
68 kg (150 lb) to GVWR	+3

(1) Add to the turns required for rider weight.

Table 26. Front Forks Compression and Rebound

RIDE SETTING	FRONT FORKS ⁽¹⁾	
	Compression (right fork)	Rebound (left fork)
Standard	2	2
Comfort	3	3
Sport	1	1

(1) Damping adjuster settings are done by turning adjuster clockwise until it stops at the maximum setting, then counting the turns counter-clockwise to the desired setting.



NOTES



SECURITY SYSTEM

Components

The security system consists of a control module, a hands-free antenna mounted on the motorcycle and a hands-free fob carried by the rider.

See SECURITY SYSTEM > ARMING AND DISARMING (Page 64).

Options

See a Harley-Davidson dealer or www.harley-davidson.com for security system options.

SECURITY SYSTEM FOB

Assigning Fob

See Figure 19. Key fobs are electronically assigned to the security system by a Harley-Davidson dealer. Only two fobs can be assigned at any one time.

Purchase replacement fobs from a Harley-Davidson dealer. The fobs can only be assigned to an individual motorcycle by a trained Harley-Davidson technician.



Figure 19. Security System Fob

NOTE

- *The module arms only if the fob has been assigned by a Harley-Davidson dealer and a Personal Identification Number (PIN) has been entered in the system. Record the PIN on the Personal Information page in the front of this Owner's Manual.*

- If the fob is misplaced or fails, the rider can refer to the *Personal Information* page in the front of this *Owner's Manual* and use the PIN to manually disarm the system. See *SECURITY SYSTEM > ARMING AND DISARMING* (Page 64) and *SECURITY SYSTEM > TROUBLESHOOTING* (Page 70).
- The rider can change the PIN at any time. See *SECURITY SYSTEM > PERSONAL IDENTIFICATION NUMBER (PIN)* (Page 62).

Fob Battery

▲ WARNING



CONTAINS BUTTON OR COIN CELL BATTERY. KEEP OUT OF REACH OF CHILDREN.

Ingestion can result in death or serious injury. Choking, chemical burns and perforation of soft tissue may result. Severe burns can occur within 2 hours of ingestion or placement in any part of the body. Seek medical attention immediately. (13105b)

Replace the fob battery every year.

NOTE

- The reusable label found on the fob packaging lists the serial number of the fob. For reference, affix the label to a blank "NOTES" page in this *Owner's Manual*.
 - See Figure 20. The serial number of the fob is also found on the inside of the fob.
1. See Figure 20. To open the fob, turn a thin blade in the slot (1).
 2. Remove the battery (2) and discard in accordance with local regulations.
 3. Install a **new** battery (Panasonic CR1632 or equivalent) with the negative side up.
 4. Align the two halves of the fob. Snap the halves together.

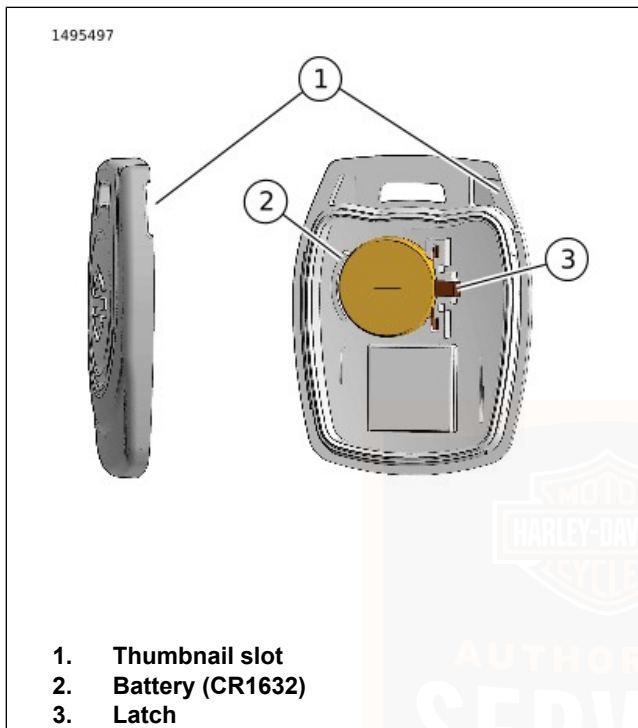

Figure 20. Replace Fob Battery

Riding with a Fob

- Always carry the fob when riding, loading, fueling, moving, parking or servicing the motorcycle.
- Do not leave the fob attached to the handlebars or store the fob in a luggage compartment. Unintentionally leaving the fob with the motorcycle when it is parked prevents the system from activating the alarm.
- Do not ride with the fob stored in a metal case or with the fob closer than 76 mm (3 in) to a mobile phone, Personal Digital Assistant (PDA), display or other electronic device. Any electromagnetic interference may prevent the fob from disarming the system.
- For added security, always lock the fork. Remove the key when parked. If the fob is within range and the motorcycle is unlocked, tampering with the motorcycle will not activate the alarm.

Riding without a Fob

If the motorcycle is ridden without the fob in acceptable proximity, the IM displays "NO FOB." To restart a motorcycle without a fob, disarm the security system with the PIN.

PERSONAL IDENTIFICATION NUMBER (PIN)

The PIN is a number that can be used to disarm the security system. Use the PIN in case the assigned fob is misplaced, fails or if the fob cannot communicate with the motorcycle because of electromagnetic interference.

A PIN is a five-digit number (1-9).

Changing the PIN

The rider can change the PIN at any time.

- Ignition must be ON
- Fob must be present
- Can select numbers between 1-9

1. Navigate dashboard menu:

- a. **Settings > General > Change Security PIN**
- b. Click OK/enter.
- c. Figure 21 The PIN screen will display.

NOTE

The zero is displayed and is only a default number. Zero cannot be part of the PIN.

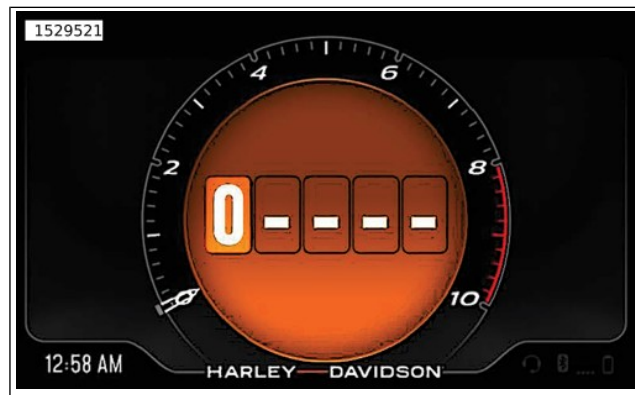
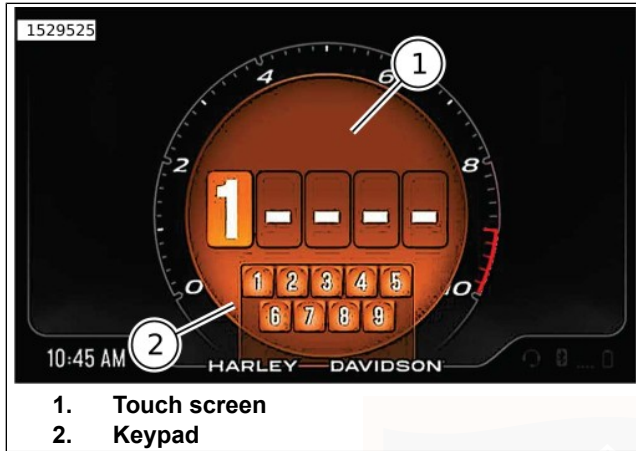

Figure 21. PIN Entry Screen

Touch Screen Entry

1. Figure 22 Touching the PIN screen (1) will display the keypad (2) entry.
2. Using the keypad enter the complete five-digit PIN.
3. Cycle the ignition to save PIN.



1. Touch screen
2. Keypad

Figure 22. PIN Screen with Keypad Entry

Hand Control Entry

1. Figure 21 Select the first digit of the PIN.
 - a. Push the left turn signal to scroll through the numbers (1-9) until the desired digit appears.
2. Figure 24 Select the next digit.
 - a. Push the right turn signal to move cursor to the right.

- b. Push the left turn signal to scroll through the numbers (1-9) until the desired digit appears.
3. Repeat step 2 until all five-digits are filled in with the desired PIN.
4. Cycle the ignition to save PIN.



Figure 23. First PIN Digit Entry



Figure 24. Moving Cursor to Next Digit

ARMING AND DISARMING

Arming

When the motorcycle is parked and the OFF/RUN switch is moved to OFF, the security system arms automatically within 5 seconds if no motion is detected. Even when the fob is present, the system arms.

On arming, the turn signals flash twice and the siren chirps twice if the siren is in the chirp mode (if equipped with a siren).

NOTE

International models: The system must be in the chirp mode for the siren to chirp on arming or disarming (if equipped with a siren). See SECURITY SYSTEM > SIREN CHIRP MODE (CONFIRMATION) (Page 68).

Disarming

With the fob present, the rider may ride or move the motorcycle for parking, storage or service without setting off the alarm. Disarming is automatic as long as the fob is within range.

Fob: An armed security system is automatically disarmed when the fob is present and the motorcycle is moved or the OFF/RUN switch is moved to RUN.

The range of the fob is approximately 1.5 m (5 ft).

When the system disarms, the siren chirps once and the security indicator lamp illuminates for a solid four seconds and then turns off.

Personal Identification Number (PIN): If the fob is misplaced or if the present fob fails to communicate, the system can be disarmed with the PIN.

Disarming with a PIN

Disarm the security system manually using the PIN if the fob is lost, the fob battery is discharged or if where you parked there is a strong electromagnetic interference.

Do not turn handlebars, straddle seat or lift motorcycle off the jiffy stand. During a PIN disarm, if the security system detects motorcycle motion the system will activate the alarm.

The PIN screen will automatically show up on the IM when the fob is not present and the vehicle has been attempted to be turned ON.

NOTE

- If a mistake is made while entering PIN, move the OFF/RUN switch to OFF before entering the last digit and then start the procedure from the beginning.
- If the procedure fails to disarm the security system, wait 2 minutes before attempting another PIN disarm.
- The security system remains disarmed until the OFF/RUN switch is moved to OFF.
- At any time during a PIN disarm if the fob is brought within range, the security system disarms as the module receives the coded signal from the fob.

Touch Screen Entry

1. Figure 25 Touching the PIN screen (1) will display the keypad (2) entry.
2. Using the keypad enter the complete five-digit PIN.
3. Push right turn signal to enter PIN.



Figure 25. PIN Screen with Keypad Entry

Hand Control Entry

1. Figure 26 Select the first digit of the PIN.
 - a. Push the left turn signal to scroll through the numbers (1-9) until the desired digit appears.
2. Figure 27 Select the next digit.
 - a. Push the right turn signal to move cursor to the right.
 - b. Push the left turn signal to scroll through the numbers (1-9) until the desired digit appears.
3. Repeat step 2 until all five-digits are filled in with the desired PIN.
4. Push right turn signal to enter PIN.



Figure 26. First PIN Digit Entry

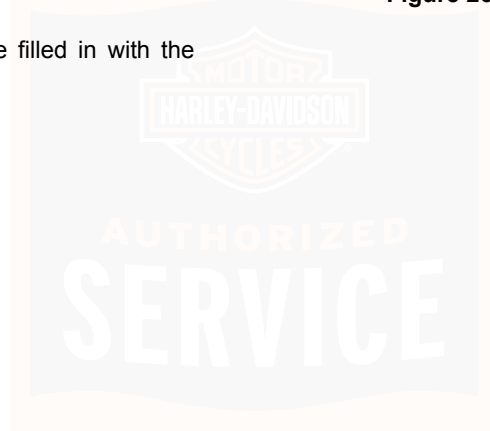



Figure 27. Moving Cursor to Next Digit

ALARM

Warnings

Once armed, if the motorcycle is moved or lifted up off of its jiffy stand and the fob is not present, the alarm will warn the operator with three alternate flashes of the turn signals and a chirp of the siren.

Within 4 seconds, if the motorcycle is back on its jiffy stand and no further motion is detected, the system will remain armed without activating the alarm.

If the motorcycle motion continues, the system will issue a second warning 4 seconds after the first.

NOTE

During warnings and alarms, the starter motor and the ignition circuits remain disabled.

Alarm Activation

If the security system is still detecting motion after a second warning, the system will activate the alarm.

When activated, the security system will:

- Alternately flash the four turn signals.
- Sound the siren (if equipped).

Duration: The alarm will stop within 30 seconds and if no motion is detected, the alarm will not restart.

However, if motorcycle motion continues the system will repeat the 30 seconds alarm and recheck for motion. The alarm will repeat this 30 seconds alarm cycle for 5 minutes (10 cycles) or until the alarm is deactivated.

Alarm Deactivation

Key fob: Bring the fob to the motorcycle. After the module identifies that the fob is present, the system will terminate the alarm.

PIN entry: Enter the PIN to deactivate the alarm. If an error is made while entering the PIN, wait until the alarm is between cycles to enter the PIN.

SIREN CHIRP MODE (CONFIRMATION)

Vehicles with optional siren can be set to chirp upon arming and disarming.

Chirp Mode

In chirp mode, the siren sounds two chirps when arming, and a single chirp when disarming.

Chirpless Mode

In chirpless mode, the siren does not chirp on arming or disarming.

The siren still provides warning chirps and sounds the alarm if the motorcycle is moved without the fob present.

Switching Modes

Perform the following to switch between chirp and chirpless modes.

1. With security fob present, set the OFF/RUN switch to RUN.
2. Count 2 seconds, set the OFF/RUN switch to OFF.

3. Before the turn signals flash twice, set the OFF/RUN switch to RUN.
4. Count 2 seconds, immediately set the OFF/RUN switch to OFF.
5. Before the turn signals flash twice, set the OFF/RUN switch to RUN. The system changes mode. The siren chirps or remains silent accordingly.

TRANSPORT MODE

It is possible to arm the security system without enabling the motion detector for one ignition cycle. The motorcycle can be moved in an armed state. The motorcycle cannot be turned on or started while in transport mode until the fob is present.

NOTE

When transporting, ensure jiffy stand and center stand (if equipped) are fully retracted to prevent damage to vehicle and powertrain components.

To Enter Transport Mode

1. With security fob present, set the OFF/RUN switch to RUN.
2. Simultaneously press both the left turn signal switch and the flash to pass button for 10 seconds.
3. While still holding the switch/button, turn ignition OFF.

4. The IM will display transport mode activated.

To Exit Transport Mode

With the security fob present, set the OFF/RUN switch to RUN to disarm the system and exit transport mode.

STORAGE AND SERVICE DEPARTMENTS

Long-Term Parking

To maintain arming, store the fob beyond the range of the antenna. The antenna range is approximately 1.5 m (5 ft). Have the fob present before moving parked motorcycle.

If the motorcycle will not be operated for several months, such as during the winter season, see AFTER RIDING > STORING MOTORCYCLE (Page 133).

Service Departments

When the motorcycle is left at a Harley-Davidson dealer, there are two options:

1. Leave an assigned fob with the dealer.

2. To maintain possession of the fob, ask the dealer to disable the system for service (service mode) before leaving the dealership. Once service mode is active, the vehicle can be operated without an assigned fob present. To maintain the service mode, the assigned fobs must be kept out of range. If the fob appears in range, the service mode is cancelled.

DISCONNECTING POWER

All Models

When disconnecting the battery or removing the main fuse, perform the following steps.

1. Verify that the fob is present.
2. Set the OFF/RUN switch to RUN.
3. Pull the main fuse from its holder.
4. Disconnect the battery if needed.

NOTE

Set the OFF/RUN switch back to OFF before installing main fuse.

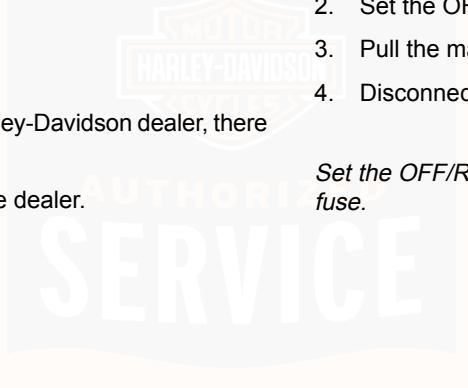

TROUBLESHOOTING

Fob

If the security system continues to actuate warnings and alarms with the fob present, check for:

1. **Electromagnetic interference:** Other electronic devices, power lines, or other electromagnetic sources can cause the security system to operate inconsistently.
 - a. Verify that the fob is not in a metal enclosure or within 76 mm (3 in) of any other electronic devices.
 - b. Place the fob on the seat and set the OFF/RUN switch to RUN. After the system disarms, return the fob to a convenient location.
 - c. Move motorcycle at least 5 m (15 ft) from the spot of interference.
2. **Discharged fob battery:** Use the PIN to disarm the system. Replace the battery. See SECURITY SYSTEM > SECURITY SYSTEM FOB (Page 59).
3. **Damaged fob:** Use the PIN to disarm the motorcycle. Replacement fobs are available for purchase from a Harley-Davidson dealer.



KEYLESS IGNITION

⚠ WARNING

The automatic-on headlamp feature provides increased visibility of the rider to other motorists. Be sure headlamp is on at all times. Poor visibility of rider to other motorists can result in death or serious injury. (00030b)

⚠ WARNING

Do not operate vehicle with forks locked. Locking the forks restricts the vehicle's turning ability, which could result in death or serious injury. (00035a)

A motorcycle with a keyless ignition does not require a key for operation. Instead, an assigned security fob must be present or the PIN must be used before the motorcycle can be started.

The key supplied with the motorcycle is for the fork lock and seat latch. See OPERATION > CONTROLS, INSTRUMENTS AND SWITCHES (Page 72).

Ignition Mode

With security fob present, set the OFF/RUN switch to RUN. The lights and instruments become operational and the motor can be started. To disarm the security system using the PIN,

see SECURITY SYSTEM > ARMING AND DISARMING (Page 64).

The motorcycle remains on (or the engine continues running) until the OFF/RUN switch is set to OFF. Taking the security fob out of range will not shut down the engine or turn off the motorcycle after it is turned on. However, the IM displays a NO FOB message when the motorcycle begins moving without the fob present.

NOTE

With the OFF/RUN switch in RUN, the system will turn off after 15 minutes of inactivity.

When parked, set the OFF/RUN switch to OFF and take the security fob from the motorcycle to prevent theft or startup. With the motorcycle turned off and the security fob out of range, the starter, ignition system and OFF/RUN switch remain disabled, immobilizing the motorcycle.

Accessory Mode

See OPERATION > LEFT HAND CONTROL SWITCHES (Page 86). With the security fob present, press and hold the TRIP switch (6). The instruments and accessory circuit are powered. The headlamp (high and low beam) and turn signal lamps remain off. While in accessory mode:

- The IM displays the odometer functions.

- Power is supplied to the Universal Serial Bus (USB) port and data transfer is enabled.
- The headlamp halo illuminates.
- The headlamp can be activated by pressing the headlamp flash to pass switch.
- The stop lamps can be operated.

To turn off accessory mode, press and hold the TRIP switch.

Do not leave the motorcycle in accessory mode for an extended period. This action can discharge the battery. If the vehicle is left in accessory mode for 2 hours, the vehicle shuts off to prevent complete battery discharge. To resume accessory mode, press and hold the TRIP switch.

CONTROLS, INSTRUMENTS AND SWITCHES

Clutch Hand Lever

⚠ WARNING

Do not position fingers between hand control lever and handlebar grip. Improper hand positioning can impair control lever operation and cause loss of vehicle control, which could result in death or serious injury. (00032a)

See Figure 4. The clutch hand lever (1) is operated with the fingers of the left hand. See OPERATION > SHIFTING GEARS (Page 117).

Figure 28 The distance between the clutch lever and hand grip can be adjusted by rotating the clutch lever adjustment dial.

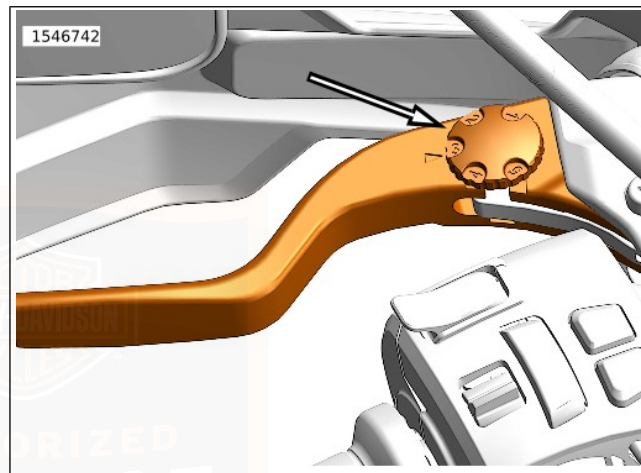

Figure 28. Clutch Lever Adjustment Dial

Gear Shift Lever

See Figure 6. The gear shift lever is operated with the left foot. Neutral is found between first and second gear in the six speed shift pattern. See OPERATION > SHIFTING GEARS (Page 117).

Left-Hand Control Module

See Figure 4. Operate the switches on the left hand control module (9) with the thumb of the left hand. See OPERATION > LEFT HAND CONTROL SWITCHES (Page 86).

Right-Hand Control Module

See Figure 4. Operate the switches on the right hand control module (7) with the thumb of the right hand. See OPERATION > RIGHT HAND CONTROL SWITCHES (Page 91).

Instrument Module

See Figure 4. The IM (3) displays vehicle instrumentation including speedometer, odometer, widgets, and telltales. See OPERATION > INSTRUMENTS (Page 75).

Brakes

▲ WARNING

Do not position fingers between hand control lever and handlebar grip. Improper hand positioning can impair control lever operation and cause loss of vehicle control, which could result in death or serious injury. (00032a)

Front brake lever: See Figure 4. The front brake lever (5) controls the front brake. Operate the hand lever with the fingers of the right hand.

See Figure 29. The distance between the brake lever and hand grip can be adjusted by rotating the brake lever adjustment dial.

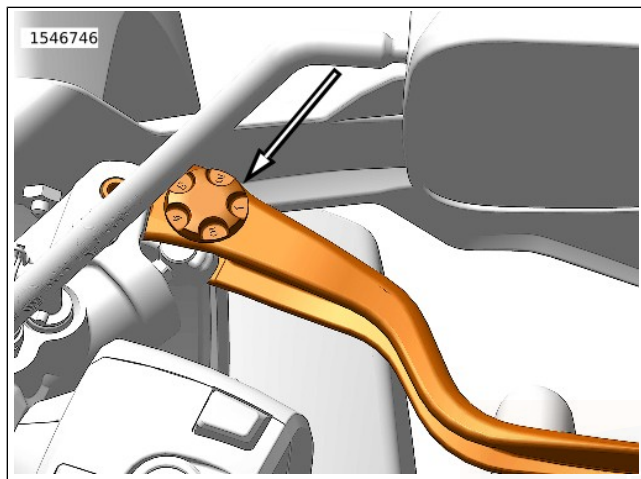

Figure 29. Brake Lever Adjustment Dial

Rear brake pedal: See Figure 5. The rear brake pedal (2) activates the rear wheel brake.

▲ WARNING

Do not apply brake strongly enough to lock the wheel. A locked wheel will skid and can cause loss of vehicle control, which could result in death or serious injury. (00053a)

Apply brakes evenly to prevent wheels from locking up. A balance between rear and front brake is best.

Throttle Twist Grip

Accelerate: See Figure 4. Slowly twist throttle twist grip (6) backward (toward rear of motorcycle) to increase speed.

Decelerate: Slowly twist throttle control grip forward (toward the front) to decrease speed.

OFF/RUN Switch

NOTE

The headlamp and tail lamps operate when the OFF/RUN switch is in the RUN position.

See Figure 36. To start the engine, see OPERATION > STARTING THE ENGINE (Page 108).

Fork Lock

▲ WARNING

Do not operate vehicle with forks locked. Locking the forks restricts the vehicle's turning ability, which could result in death or serious injury. (00035a)

NOTICE

Protect your vehicle against theft. Failure to lock the motorcycle after parking could result in theft and/or equipment damage. (00151b)

See Figure 30. The fork lock is located in the triple clamp on the right side and is locked with the key.

Using the fork lock immediately after parking your motorcycle will discourage unauthorized use or theft.

1. Turn fork to full left position.
2. Insert key into fork lock.
3. Turn key to right position (clockwise).
4. Remove key.
5. To unlock fork, insert key into fork lock and turn to the left position (counter-clockwise). Remove lock key.
6. Check steering for proper operation by turning the handlebars through the full operating range. Handlebars should turn smoothly without binding.

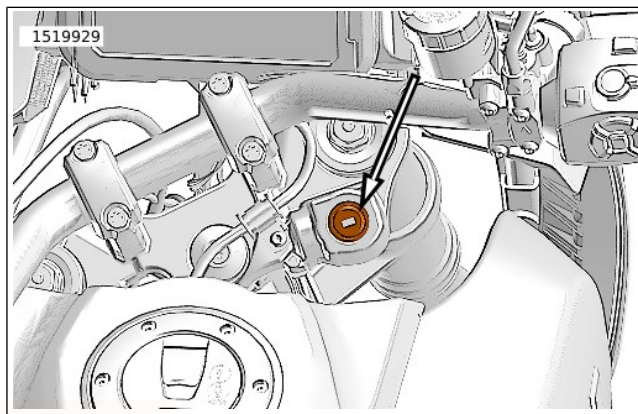

Figure 30. Fork Lock

INSTRUMENTS

NOTICE

There are no serviceable parts inside the unit; leave all servicing to qualified service personnel. Disassembly of the unit could result in equipment damage and/or equipment malfunction. (00172a)

SERVICE

Updating Software

1. Check software version.
 - a. Refer to: OPERATION > INFOTAINMENT (Page 95). Navigate to Settings> Software> Software Information. This menu will show the current software version on the IM.
 - b. Check for latest software version. See website: www.h-d.com/infotainment-support.
2. Update software.
 - a. Download the latest software version to Universal Serial Bus Type-C (USB-C) device. See website: www.h-d.com/infotainment-support.
 - b. Unzip the downloaded file to extract the gpg file. The gpg file must be at the root directory of your USB-C drive in order for it to be detected by the IM. Only one gpg file should be present at the root directory level.
 - c. See Figure 42. Connect USB-C drive to motorcycle.
 - d. Navigate to Settings> Software> Infotainment SW Update.
 - e. Verify correct update is available.
 - f. Load update.
 - g. Allow update to complete.
 - h. Remove USB-C drive.
3. Return to Software Information to verify correct version has been loaded.

Fuel Gauge

See Figure 31. The fuel gauge indicates the approximate amount of fuel in the fuel tank.

Speedometer

⚠ WARNING

Travel at speeds appropriate for road and conditions and never travel faster than posted speed limit. Excessive speed can cause loss of vehicle control, which could result in death or serious injury. (00008a)

See Figure 31. The IM registers Miles Per Hour (mph) (U.S. models default) and Kilometers Per Hour (km/h) (international models default). The IM can be configured to register either mph or km/h through the settings menu.

Tachometer

See Figure 31. The tachometer measures the engine speed in revolutions per minute (rpm x 1000).

Clock

See Figure 31. The clock displays current time in 12/24 hour format. The settings menu is used to set time and select 12 or 24 hour format.

Odometer display

Pressing the trip button with the OFF/RUN switch in either position activates the odometer reading.

See Figure 31. The odometer display provides the following selectable displays:

- Odometer
- Trip odometer A
- Trip odometer B
- Range
- Temperature (If equipped)

Press and release the trip button to cycle through the displays.

To check trip mileage or to reset trip odometers, the OFF/RUN switch must be in the RUN position. Press and release the trip button until the desired trip odometer is displayed.

To reset or zero trip odometers, have desired (A or B) odometer displayed. Press the trip button and hold for approximately one second. The trip odometer resets to zero.

The fuel range display shows the approximate mileage available with the amount of fuel left in the fuel tank. With OFF/RUN switch in the RUN position, press the trip button until range is displayed.

If equipped, the temperature display shows ambient temperature. With OFF/RUN switch in the RUN position, press the trip button until temperature is displayed.

Widgets

See Figure 31. Widgets can be displayed on the four corners of the IM. Each selectable widget displays unique additional information on the IM.

See OPERATION > WIDGETS (Page 100).

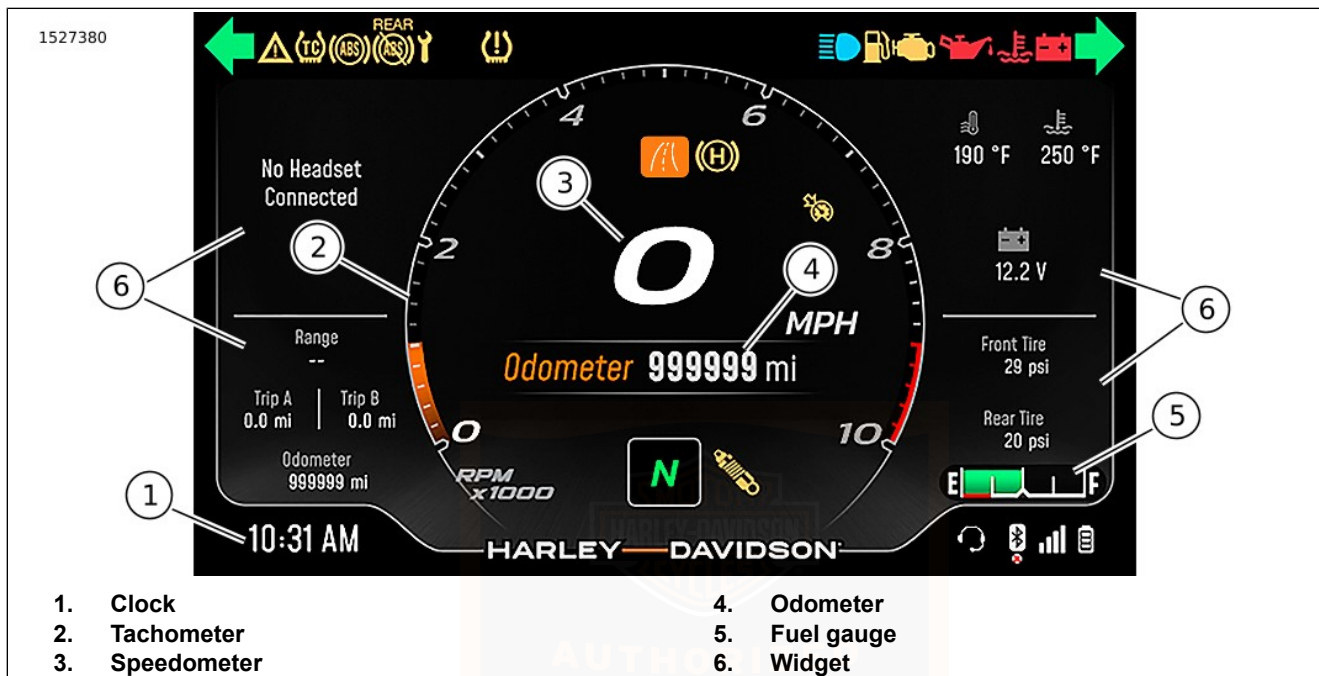

Figure 31. Instruments: Dashboard Display

INDICATORS

Service Lamps

See Figure 32. The service lamps indicate the condition of the powertrain/powertrain management system.

Fault Alert: The fault alert indicator (2) turns on when the vehicle has detected a fault. See a Harley-Davidson dealer for service.

Check Engine: The check engine indicator (12) normally turns on when the ignition is first turned on. During this time, the powertrain management system runs a series of self-diagnostics. If the indicator remains on after startup, see a Harley-Davidson dealer for service.

Maintenance: The maintenance indicator turns on when the vehicle has detected that the fluid needs to be changed and requires an ABS bleed procedure to be performed. See a Harley-Davidson dealer for service.

Battery Fault Indicator

See Figure 32. The battery fault indicator turns on when overcharging or undercharging of the battery is detected. Refer to: SERVICE PROCEDURES > BATTERY MAINTENANCE (Page 157).

Coolant Temperature Indicator

▲ WARNING

Do not loosen or remove pressure cap when cooling system is hot. The cooling system is under pressure and hot coolant and steam can escape from pressure cap, which could cause severe burns. Allow motorcycle to cool before servicing the cooling system. (00091c)

NOTICE

If the engine coolant temperature indicator lamp remains lit, always check the coolant level. If the coolant level is normal and the lamp is still lit, stop the engine at once and do not ride further until the trouble is located and the necessary repairs are made. Failure to do so may result in engine damage. (00158a)

See Figure 32. The coolant temperature Indicator turns on when the coolant has exceeded threshold temperature.

If coolant level is sufficient and the indicator remains on, see a Harley-Davidson dealer for service.

Oil Pressure Indicator

NOTICE

If the oil pressure indicator lamp remains lit, always check the oil supply first. If the oil supply is normal and the lamp is still lit, stop the engine at once and do not ride further until the trouble is located and the necessary repairs are made. Failure to do so may result in engine damage. (00157a)

See Figure 32. The oil pressure indicator turns on when the ignition is turned on. The indicator remains on until the engine is started.

If the indicator is on while the engine is running, sufficient oil is not circulating through the engine.

Check and add engine oil as necessary. Refer to: MAINTENANCE AND LUBRICATION > CHECK ENGINE OIL LEVEL (Page 138). For other possible causes, Refer to: TROUBLESHOOTING > ENGINE (Page 179).

If the engine oil level is sufficient and the lamp remains on, stop the engine immediately. See a Harley-Davidson dealer for service.

Low Fuel Indicator

See Figure 32.

Solid: The low fuel warning indicator turns on when the fuel in the tank reaches the low fuel level (approximate). See OWNER MANUAL > SPECIFICATIONS (Page 29) for the low fuel level. For fuel range feature, see OPERATION > INSTRUMENTS (Page 75).

Flashing: If the low fuel lamp flashes continuously or remains on after filling the fuel tank, see a Harley-Davidson dealer.

Adaptive Ride Height Indicator (models with)

See Figure 32.

Off: Suspension is at normal ride height.

Flashing: Suspension is lowered.

Solid: The indicator is solid if ARH has been locked at ride height in the settings menu or if there is a fault with the ARH system. If ARH is enabled in the settings menu and indicator is solid see a Harley-Davidson dealer for service.

Ride Mode Indicator

See Figure 32. The ride mode Indicator displays the current selected ride mode. See OPERATION > RIDE MODES (Page 100).

Hill Hold Control Indicator (models with)

See Figure 32.

Solid: Hill Hold Control (HHC) is engaged and maintaining brake pressure.

Slow flashing: Indication that brake pressure is being released, or is about to be released automatically. The rider should be prepared to engage the brake manually or drive off

Heated Hand Grip Indicator (models with)

See Figure 32.

Indicates status of heated hand grips. Refer to: OPERATION > HEATED HAND GRIPS (Page 105).

Gear Indicator

See Figure 32. The gear indicator shows the currently selected gear (1-6) and neutral.

Turn Signal Indicators

See Figure 32.

Flashing: A turn signal is activated. When the 4-way hazard flashers are operating, both turn indicators flash simultaneously.

Rapid flashing: A turn signal is not operating. Exercise caution and use hand signals. Replace inoperative components at earliest opportunity.

Headlamp High Beam Indicator

See Figure 32. The headlamp high beam indicator is on when the high beam or flash to pass switch is activated.

Cruise Control Indicator

See Figure 32.

Off: Cruise control is not enabled.

Enabled - speed not set: Cruise control is enabled, cruising speed is not set. Cruise indicator shown in amber color.

Enabled - speed set: Cruising speed is set. Motorcycle speed is maintained by the cruise control system. Cruise indicator shown in green color.

ABS Indicators

ABS Indicator:

See Figure 32.

▲ WARNING

If ABS lamp continues flashing at speeds greater than 5 km/h (3 mph) or remains on continuously, the ABS is not operating. The standard brake system is operational, but wheel lock up can occur. Contact a Harley-Davidson Dealer to have ABS repaired. A locked wheel will skid and can cause loss of vehicle control, which could result in death or serious injury. (00361b)

Flashing: The Anti-lock Braking System (ABS) indicator (4) begins flashing when the vehicle is turned on. The flashing indicates that the system is in self-diagnosis mode. It continues to flash until motorcycle speed exceeds 5 km/h (3 mph). ABS is not operational until the lamp turns off.

Solid: Continuous illumination indicates an ABS malfunction. The ABS is disabled and the brakes are operating as if they were non-ABS brakes. See a Harley-Davidson dealer for service.

▲ WARNING

Rapid flashing of the ABS lamp while the fault alert and traction control lamps are lit indicates a potential brake system fault. Move the motorcycle out of traffic applying both front and rear brakes to reduce speed and to stop motorcycle in a safe location. Contact a Harley-Davidson dealer for brake system repair. Operating a motorcycle with an improperly functioning brake system can adversely affect brake performance, which could result in death or serious injury. (11610a)

Rapid flashing with solid fault alert and traction control lamps: This indicates a potential brake system fault. Apply both front and rear brakes to reduce speed and to stop motorcycle. The brake controls could feel stiff when applied. If this occurs, move the motorcycle to a safe location to stop. Service is required to correct the fault before continuing to ride. See a Harley-Davidson dealer for service.

Rear ABS Indicator: The rear ABS indicator (5) illuminates when the rear wheel ABS has been disabled. This occurs when the selected ride mode requires the rear ABS to be disabled, this is not a fault indicator.

Table 27. ABS Indicator State

ABS INDICATOR	STATE
ABS indicator Flashes	START-UP: ABS indicator check.
ABS indicator OFF	NORMAL OPERATION: After vehicle speed > 5 km/h (3 mph).
ABS indicator Continuous	ABS not functioning.
ABS indicator Rapid Flash with Solid Fault Alert and Traction Control indicator	Brake System Fault, Do not ride.

Tire Pressure/TPMS Fault Indicator

⚠ WARNING

Be sure tires are properly inflated, balanced, undamaged, and have adequate tread. Inspect your tires regularly and see a Harley-Davidson dealer for replacements. Riding with excessively worn, unbalanced, improperly inflated, overloaded or damaged tires can lead to tire failure and adversely affect stability and handling, which could result in death or serious injury. (00014b)

See Figure 32. The low tire pressure/Tire Pressure Monitoring System (TPMS) fault (7) indicates when a low tire pressure condition or a TPMS system fault has occurred.

Flashing (60 seconds, followed by solid lamp): TPMS fault has been detected. This event can occur for a variety of reasons, including loss of signal from the sensors or sensor battery failure. Tire pressure data may not be available while the lamp is lit. See a Harley-Davidson dealer for service.

Solid: The system has detected that one or more tires have low pressure. Safely stop the vehicle and use a tire pressure gauge to check the pressure of each affected tire. Inflate the tires according to specifications in BEFORE RIDING > CHECKING TIRE PRESSURE AND INSPECTING TIRES (Page 39), or as specified on the label on the frame downtube. The indicator will turn off when you begin riding the motorcycle with the correct pressure in the tires. Also refer to BEFORE RIDING > CHECKING TIRE PRESSURE AND INSPECTING TIRES (Page 39) to compensate tire pressures for tires that have recently been ridden.

Traction Control Indicator

See Figure 32.

Solid: Traction control has been turned off.

Flashing: Traction control system active intervention.

Off: Traction control system is on.

Solid with fault alert indicator illuminated: Continuous illumination of the traction control indicator along with the alert indicator illuminated indicates a traction control fault. Traction

control may be disabled and the motorcycle may be operating as if traction control is turned off. See a Harley-Davidson dealer for service.

Bluetooth Indicator

See Figure 32. The bluetooth indicator displays the connection status of a wireless device. When connected to a device the indicator will be white, when no connection is detected the indicator will be grey.

Bluetooth Application Status Indicator

See Figure 33. The bluetooth application status indicates the following.

- **Solid white:** Connected to application.

- **Empty:** Connected to application and is offline with no data being transferred.
- **Red:** Not connected to application.

Device Battery Indicator

See Figure 32. Bluetooth connected device battery level.

Device Signal Indicator

See Figure 32. Bluetooth connected device signal strength.

Headset Connection Indicator

See Figure 32. The headset indicator displays the connection status of the headset. When connected the indicator will be white, when no connection is detected the indicator will be grey.

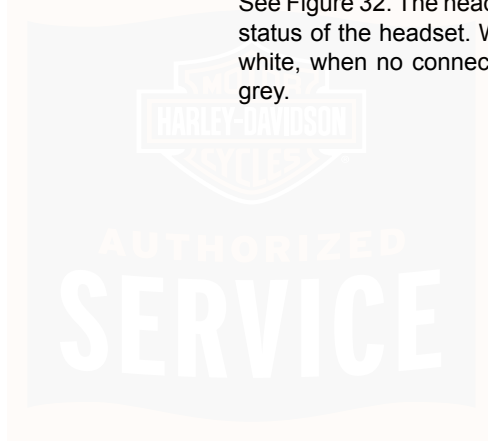

1527564

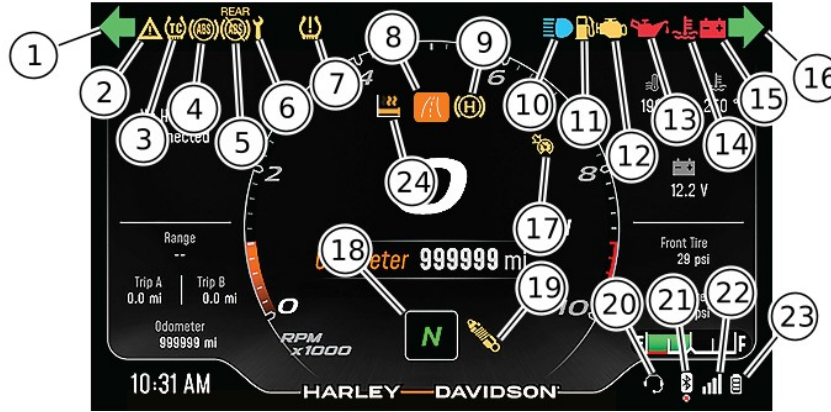

- | | |
|----------------------------|------------------------------------|
| 1. Left turn signal | 13. Oil pressure |
| 2. Fault alert | 14. Coolant temperature |
| 3. Traction control | 15. Battery discharge |
| 4. ABS | 16. Right turn signal |
| 5. Rear wheel ABS disabled | 17. Cruise control |
| 6. Maintenance required | 18. Gear indicator |
| 7. TPMS fault | 19. ARH (models with) |
| 8. Ride mode | 20. Headset connection |
| 9. HHC (models with) | 21. Bluetooth |
| 10. Headlamp high beam | 22. Device signal |
| 11. Low fuel | 23. Device battery |
| 12. Check engine | 24. Heated hand grip (models with) |

Figure 32. Instrument Module Indicators

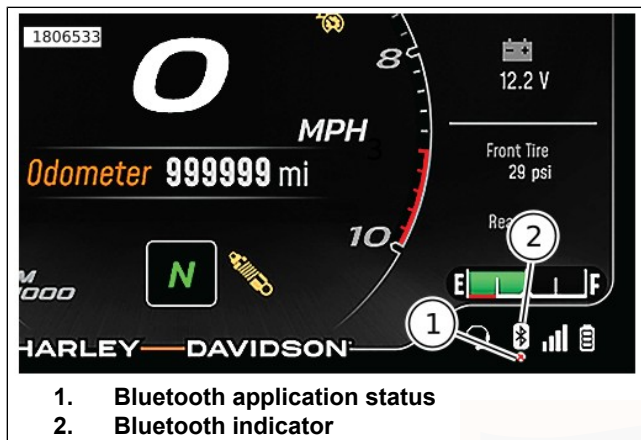

Figure 33. Bluetooth Symbol

LEFT HAND CONTROL SWITCHES

Headlamp Switch

- **Flash to Pass:** Figure 34 When the headlamp switch (3) is in the low beam position, press down and release the headlamp switch to use the flash to pass to flash the high beam before passing another vehicle. The high beam indicator on the IM is illuminated as long as the flash to pass button is pressed. When in accessory, press the flash to pass button to activate the headlamp.

- **Low Beam:** Figure 34 From the high beam position, press the headlamp switch (3) down to activate the low beam.
- **High Beam:** Figure 34 Press the headlamp switch (3) up to activate the high beam. The (blue) high beam indicator lamp is lit when the high beam is on.

Cruise control ON

Figure 34 Press the cruise ON button (4) to turn ON cruise control. The cruise icon in the IM turns amber.

Cruise control OFF

Figure 34 Press the cruise OFF button (7) to turn OFF cruise control. The cruise icon in the IM turns off.

Cruise control set/decrease speed

Figure 34 When the motorcycle reaches your intended speed, press the **SET/-** switch (1) to set the cruise speed. The amber cruise icon in the IM turns green.

Tapping the **SET/-** switch decreases speed by 1.6 km/h (1 mph). Holding the **SET/-** switch down gradually decreases cruise speed.

Cruise control resume/increase speed

Figure 34 If cruise has been disengaged yet the cruise indicator is amber, pressing the **RES/+** switch (2) resumes

cruise. The icon in the IM glows green. The motorcycle automatically resumes cruise at the set speed.

Tapping the **RES/+** switch up increases speed by 1.6 km/h (1 mph). Holding up the **RES/+** switch gradually increases cruise speed.

Heated hand grips (if equipped)

Figure 34 Press the heated hand grip button (5) to turn on the heated grips. Tapping the heated hand grip button will change the heat setting. See OPERATION > HEATED HAND GRIPS (Page 105).

Trip

Figure 34 The trip button (6) activates the trip odometers. The trip button also is used to scroll through the optional screens of the odometer display. With the ignition off, the trip button can activate time or odometer displays.

Home

Figure 35 Pressing the home button (5) will return the IM back to the speedometer/odometer screen.

Menu

Figure 35 Press the Menu button (3) to access IM menu selections. Refer to: OPERATION > INFOTAINMENT (Page 95).

Navigate left

Figure 35 Press the navigate left button (1) to scroll left on the IM.

Navigate up

Figure 35 Press the navigate up button (2) to scroll up on the IM.

Navigate right

Figure 35 Press the navigate right button (4) to scroll right on the IM.

Navigate down

Figure 35 Press the navigate down button (6) to scroll down on the IM.

Turn signals/cancel

- **Left turn signal:** Figure 35 Push the turn signal switch (7) to the left to activate the left turn signal.

- **Right turn signal:** Figure 35 Push the turn signal switch (7) to the right to activate the right turn signal.
- **Cancel:** Figure 35 Press the turn signal switch (7) straight in to manually cancel the signals.

Horn

Figure 35 The horn is operated by pressing the horn button (8). The horn can be activated for up to 10 seconds at a time. If the horn button is held for a longer period, the horn automatically deactivates.

OK/enter

Figure 35 Push the OK/enter button (9) to approve or enter a section in the IM.

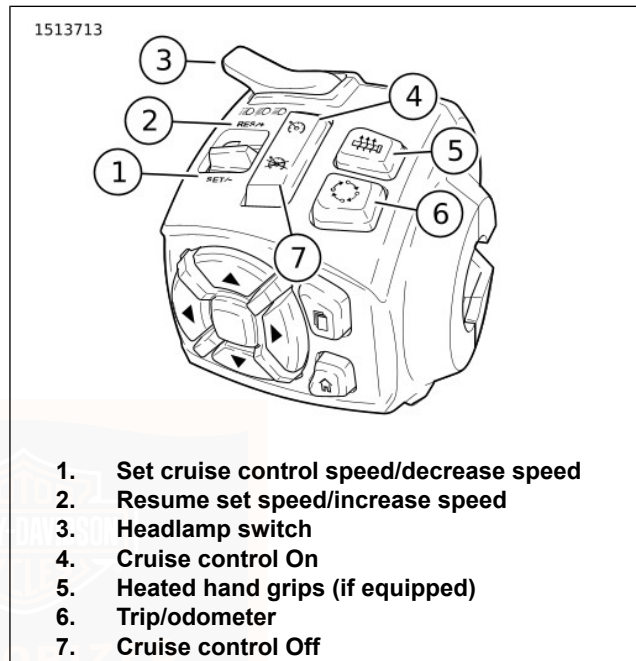

Figure 34. LHCM - Top

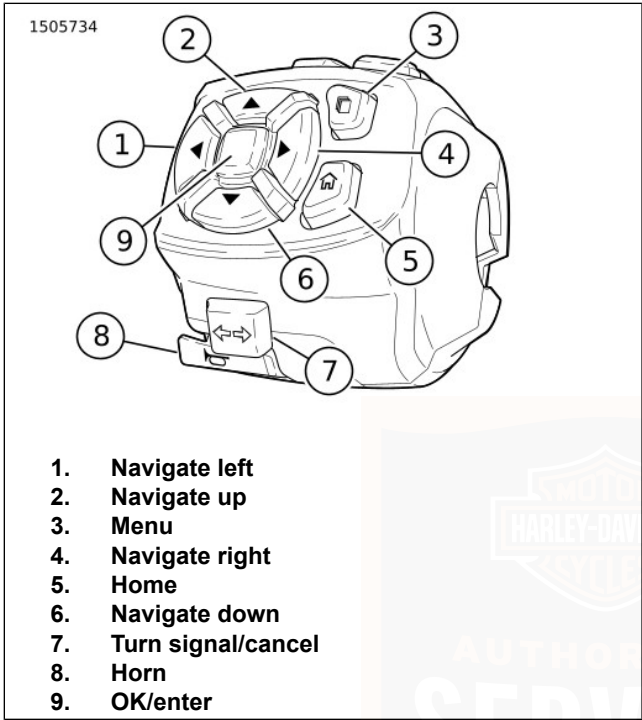

Figure 35. LHCM - Bottom

Table 28. Left Hand Control Switches/Buttons

SWITCH/ BUTTON	NAME	FUNCTION
SET/-	Cruise control set/ decrease speed	Press switch to set cruise control speed.
RES/+	Cruise control resume/ increase speed	Press switch to resume to a set cruise control speed.
	Flash to pass	Press and release to flash the high beam. In ACC, press to activate the headlamp.
	Low beam	Press the switch to switch the headlamp to low beam.
	High beam	Press the switch to switch the headlamp to high beam.
	Cruise control ON	Press the button to turn cruise control ON.

Table 28. Left Hand Control Switches/Buttons





SWITCH/ BUTTON	NAME	FUNCTION
	Heated hand grips	Press the button to turn heated hand grips ON and select heat settings. (If equipped)
	Trip	Press the button to alternate odometer displays.
	Cruise control OFF	Press the button to turn cruise control OFF.
	Navigate left	Press the button to go left on IM screen.
	Navigate up	Press the button to go up on IM screen.

Table 28. Left Hand Control Switches/Buttons



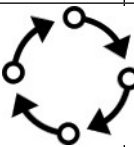



SWITCH/ BUTTON	NAME	FUNCTION
	Menu	Press the button to navigate through menus in the IM.
	Navigate right	Press the button to go right on IM screen.
	Home	Press the button to return the speedometer/odometer screen.
	Navigate down	Press the button to go right on IM screen.

Table 28. Left Hand Control Switches/Buttons

SWITCH/ BUTTON	NAME	FUNCTION
	Turn signal <ul style="list-style-type: none"> • Left turn signal • Right turn signal • Manual cancel 	Press the switch to signal.
	Horn	Press the button to sound horn.

RIGHT HAND CONTROL SWITCHES

Hazard Warning 4-Way Flasher

See Figure 36. The hazard switch (1) is used to leave a stranded motorcycle in the 4-way flashing mode. With the flashers, the motorcycle can be left with the ignition off until assistance is found.

1. With the OFF/RUN switch in the run position, press on the hazard warning triangle to activate the 4-way flashers.

NOTE

- The fob must be present when turning on the 4-way flashers and when canceling the flashers.
 - The four-way flashers will operate when the vehicle is tipped over regardless of OFF/RUN switch position. See OPERATION > STARTING AFTER TIPOVER (Page 109).
2. Turn OFF/RUN switch to the off position. The 4-way flashers continue for 2 hours or until cancelled by the rider.
 3. To cancel, turn the OFF/RUN switch to the run position. Press the warning triangle above the start switch.

Mode

See Figure 36. Press the mode button (2) to change the ride mode.

OFF

See Figure 36. Position the engine OFF/RUN switch to the Off position (3) to shut off the engine.

RUN

See Figure 36. Push the engine OFF/RUN switch to run (5) to enable engine start and run. The engine OFF/RUN switch must be in the run position to start or operate the engine.

Start

See Figure 36. Position the engine OFF/RUN switch to the Run position (5) to allow the engine to start.

1. Switch the OFF/RUN switch to the run position (5). Shift the transmission to neutral. The neutral (green) indicator illuminates. See OPERATION > STARTING THE ENGINE (Page 108).
2. Press the start switch (4) to operate the starter motor.

NOTE

- *When the starter is activated, the headlamp is momentarily turned off to reduce battery load.*
- *If the engine does not start, the starter motor runs for 10 seconds and stops with a single press. Press the start switch to try again. After several unsuccessful attempts to start the engine, see a Harley-Davidson dealer.*

Previous

See Figure 37. Press the previous button (1) to select the previous media file.

Next

See Figure 37. Press the next button (4) to select the next media file.

Play/pause

See Figure 37. Press the play/pause button (2) to play or pause the current media file.

Volume up

See Figure 37. Press the volume up button (3) up to increase volume.

Volume down

See Figure 37. Press the volume up button (5) up to decrease volume.

Voice recognition

See Figure 37. The voice recognition switch (6) activates the voice recognition features on a connected mobile device.

Traction control

See Figure 37. The traction control button (7) activates and deactivates the traction control system.

- **Disable:** Press button for 1 second with engine running and vehicle stopped.
- **Enable:** Press button at anytime to resume traction control operation.

1513812

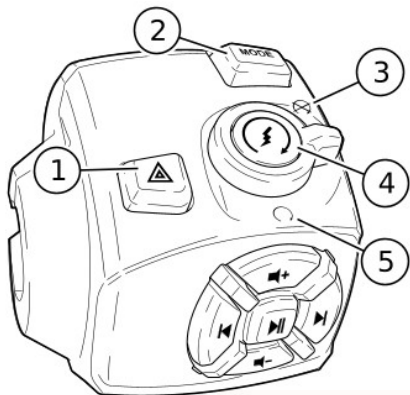

1. Hazard
2. Mode
3. Off
4. Start
5. Run

Figure 36. RHCM - Top

1513811

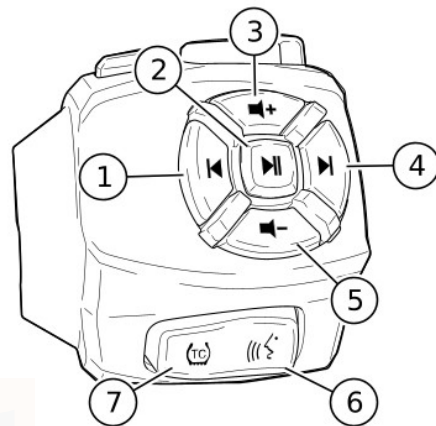

1. Previous
2. Play/pause
3. Volume up
4. Next
5. Volume down
6. Voice recognition
7. Traction control

Figure 37. RHCM - Bottom

Table 29. Right Hand Control Switches/Buttons





SWITCH/ BUTTON	NAME	FUNCTION
	Hazard	Press to activate the 4-way flashers.
MODE	Mode	Press to change the ride mode.
	Off	Position to stop the engine or to prevent the engine from starting.
	Start	Press to start the engine.
	Run	Position to allow the engine to start.
	Previous	Press to select the previous media file.

Table 29. Right Hand Control Switches/Buttons





SWITCH/ BUTTON	NAME	FUNCTION
	Play/pause	Press to play or pause the current media file.
	Volume up	Press to increase volume.
	Next	Press to select the next media file.
	Volume down	Press to decrease volume.

Table 29. Right Hand Control Switches/Buttons

SWITCH/ BUTTON	NAME	FUNCTION
	voice recognition	Initiates a voice recognition session.
	Traction control	Press to deactivate and activate traction control.

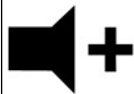
INFOTAINMENT

SAFETY

Follow all warnings, cautions and safety tips in this Owner's manual.

⚠ WARNING

Set volume levels and other controls on audio and electronic devices before riding. Distractions can lead to loss of control, resulting in death or serious injury. (00088b)

⚠ WARNING

Do not select a volume level that blocks out traffic noise or interrupts the concentration necessary for safe operation of the motorcycle. Distractions or a volume level that blocks out traffic noise could cause loss of control resulting in death or serious injury. (00539b)

NOTICE

There are no serviceable parts inside the unit; leave all servicing to qualified service personnel. Disassembly of the unit could result in equipment damage and/or equipment malfunction. (00172a)

NOTE

To make full use of features and minimize distraction while on the road, configure the system with your personal preferences before riding.

CONTROLS

Instrument Module (IM)

See Figure 38. To access the menu selections on the IM press the menu button (3) on the Left Hand Control Module (LHCM).

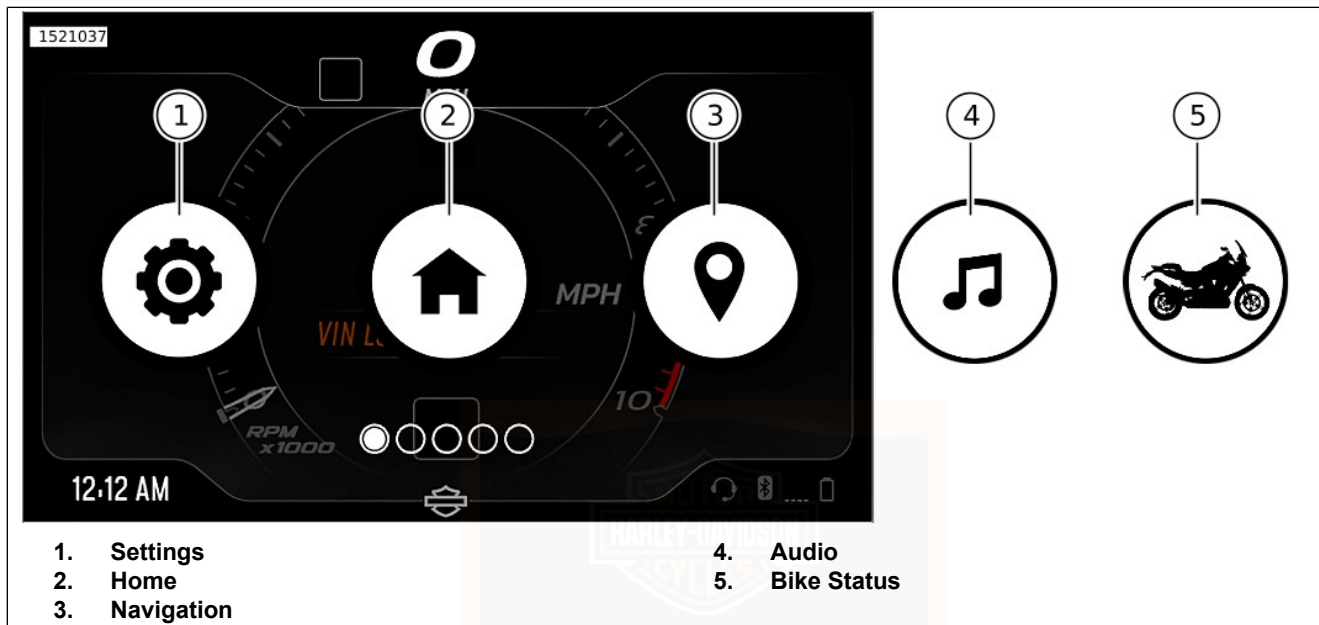

Figure 38. Menu Selections

Hand Controls

See Figure 35 and Figure 37.

BLUETOOTH

Pairing Device

1. Activate Bluetooth on your device.

2. See Figure 38. **Select:** settings menu (1).
3. **Select:** Bluetooth
4. **Select:** Add new device.
 - a. **Phone:Select:** Add New Phone
 - b. **Headset:Select:** Add New Headset
5. Follow on screen prompts to complete pairing.

Audio

NOTE

A phone and headset must be paired to the IM before audio functions can be used.

See Figure 38. To access audio functions **Select:** audio card (4).

Use the Right Hand Control Module (RHCM) to control audio functions. Refer to: OPERATION > RIGHT HAND CONTROL SWITCHES (Page 91).

PHONE

NOTE

- *A phone must first be paired before call or text notifications can be viewed through the IM.*
- *A headset with microphone is required to make and receive calls via Bluetooth.*

Notifications

Call and text notifications can be turned on or off through the settings menu.

1. See Figure 38. **Select:** settings menu (1).
2. **Select:** Phone Notifications.
3. Adjust notification settings.

Making a Call

See Figure 37. Voice recognition can be used to place a call through the IM.

Receiving a Call

See Figure 39. When receiving a call a notification will be displayed on the IM.

Use the LHCM to answer or decline the call.

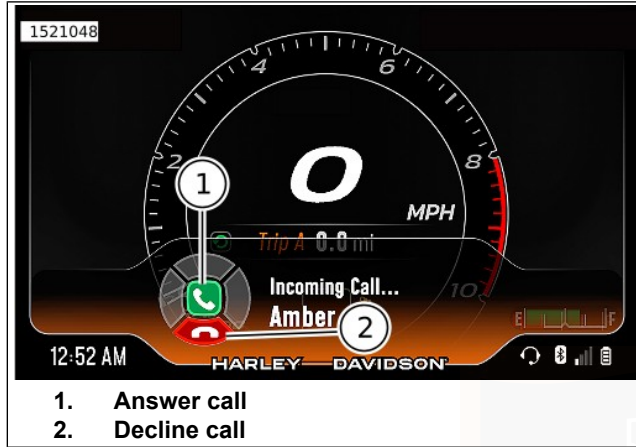

Figure 39. Incoming Call

VOICE RECOGNITION

NOTE

See Figure 37. The voice recognition switch (6) activates voice recognition features on a connected device (if supported). With a headset connected, press the voice recognition switch. Speak the desired command into the headset microphone.

NAVIGATION

NOTE

- A device using the H-D Mobile App must be paired to the IM before navigation can be used.
- Some features require a cellular connection to function. Operating without cellular connectivity for long periods may disrupt map display. For best maps and navigation experience in areas with poor cellular connectivity, download your desired map areas in advance using the H-D Mobile App.
- Navigation not available in all markets.

The navigation function is intended to assist you when traveling. In some circumstances, information provided by the navigation function may be incomplete, incorrect or outdated. Road conditions, traffic laws and restrictions (such as no left turns, street closures, one way streets, road construction detours, and so on) can frequently change. Before following any instruction, check that the instruction can be done safely and legally. Program and review navigation routes with the vehicle stopped. If necessary, safely park the vehicle if there is difficulty following the route guidance or to program a new route.

Navigation Displays

Moving Maps

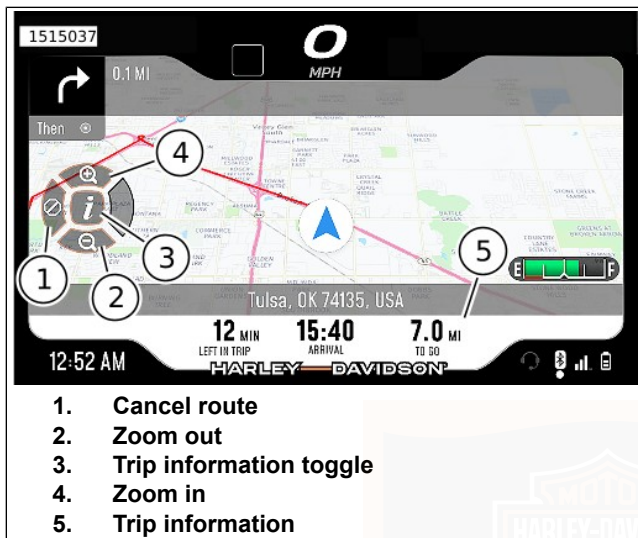

Figure 40. Moving Maps

Turn by Turn

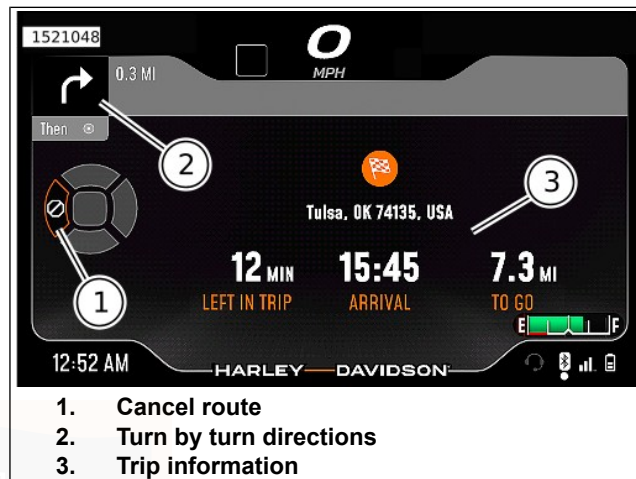

Figure 41. Turn By Turn

Setting Route

The navigation function requires information that has been entered into the connected device using the H-D Mobile App. For more information see www.harley-davidson.com.

Bike Status

Selecting the bike status card (5) displays vehicle information including, TPMS data, engine coolant temperature, and battery voltage.

WIDGETS

Widgets are small customizable displays that allow the rider to see select additional information on the IM.

Widgets are customizable through the settings menu on the IM. To use widgets the widget display must be selected from the settings menu, Appearance > Dashboard Customization > Widget. Once selected, a maximum of four desired widgets can be selected and customized. See OPERATION > INSTRUMENTS (Page 75).

Trip

The trip widget displays fuel range, odometer reading, trip A and trip B mileage.

Bike Status

The Bike status widget displays ambient temperature, coolant temperature and battery voltage.

Audio

The audio widget displays music information from a connected device. This information includes song title, artist name, album title, play pause icon and song duration.

NOTE

Must be used with a connected device through a connected headset.

Navigation

The navigation widget displays turn by turn navigation information that has been entered into the connected device using the HD app. This information includes next action icon, distance to next action and arrival time information.

TPMS

The TPMS widget displays tire pressure data for front and rear tire.

RIDE MODES

Ride Modes

Refer to Table 30. The ride mode icon displays the currently selected ride mode. The selected ride mode can be changed using the mode button on the RHCM. Refer to: OPERATION > RIGHT HAND CONTROL SWITCHES (Page 91).

NOTE

If a fault is detected, a ride mode fault icon will be shown in place of the ride mode icon.

- **Ride Mode Fault:** Displays when system fault is detected by vehicle. When fault is detected, cycle ignition.
 - With security fob present, set the OFF/RUN switch to OFF.
 - Wait 45 seconds.
 - Set the OFF/RUN switch to ON.

If cycling ignition system does not eliminate fault, see a Harley-Davidson dealer for service.

- **Road:** Delivers balanced performance with an intuitive blend of technology for daily use, with ABS and Traction Control System (TCS) intervention that offers peace of mind. On models with enhanced semi-active suspension, this mode will also adjust suspension damping to a balanced setting with increased comfort over Sport.
- **Rain:** This mode offers restrained acceleration and limited engine braking with higher levels of ABS and traction control intervention to give the rider greater confidence when riding in the rain or when traction is otherwise limited. The Rain Mode is also an appropriate setting for riders to build confidence as they become familiar with the motorcycle. On models with enhanced semi-active suspension, this mode will also adjust suspension damping to a compliant comfort setting.

- **Sport:** Delivers the full performance potential of the motorcycle in a direct and precise manner, with full power and the quickest throttle response on tap. Traction control is set to its lowest level of intervention intended/appropriate for on-road use, and engine braking is increased. Sport Mode maximizes the rider connection to the motorcycle for a direct and visceral performance riding experience. On models with enhanced semi-active suspension, this mode will also adjust suspension damping to a sport setting with higher damping rates and minimal float.
- **Off-Road:** Midrange level of power with torque characteristics tailored for use in an off-road environment. Antilock braking is active on both wheels, with interventions designed specifically for loose unpaved surfaces. Traction control intervention is at the same level as sport mode. On models with enhanced semi-active suspension, this mode will also adjust suspension damping to an off-road use targeted setting with increased initial damping.

- **Off-Road Plus:** Same engine performance as Off-Road mode, with key changes to ABS and TCS that best support use in off-road environments by an experienced rider. Rear wheel ABS is disabled, front to rear electronically linked braking function is disabled, and drag-torque slip control is disabled. The TCS provides the least intervention available. Front wheel lift mitigation and rear wheel lift mitigation are also disabled. Cornering enhancements to TCS, and front wheel ABS are disabled, these systems will be at their lowest level of intervention regardless of motorcycle lean angle. This mode should only be used by experienced riders in an off-road environment with a properly equipped vehicle. On models with enhanced semi-active suspension, this ride mode will also change suspension damping to have less initial damping.

NOTE

To enter Off-Road Plus ride mode, enter Off-Road ride mode, then hold down the "MODE" button until Off-Road Plus icon appears.

- **Custom Modes A, B and Custom Off-Road:** Custom Modes allow the rider to select their own preference of engine torque delivery characteristics, engine braking, Throttle Response, TCS, ABS, and Suspension damping levels within specific ranges. Vehicles with the ARH option have the ability to adjust the timing of when the system will automatically lower or to keep it at ride height.

- **Custom Off-Road Plus Mode:** Meant for use in an off-road environment by an experienced rider. Uses same performance settings chosen for Custom Off-Road mode, except the ABS and traction control settings will match the pre-programmed Off-Road Plus mode to best support use in an off-road environment by an experienced rider. ABS function on the rear wheel is disabled, front to rear electronically linked braking function is disabled, and drag-torque slip control is disabled. The traction control system changes to the least intervention available. Front wheel lift mitigation and rear wheel lift mitigation are also disabled. Cornering enhancements to traction control, and front wheel antilock braking are disabled, meaning these systems will be at their lowest level of intervention regardless of motorcycle lean angle. On special models, the suspension setting selected in custom off-road ride mode will carry over into this ride mode.



NOTE

- *Custom Off-Road ride mode must be configured before Custom Off-Road Plus mode can be used.*
- *Off-Road modes are only available on the RA1250S.*
- *To enter Custom Off-Road Plus ride mode, enter Custom Off-Road ride mode, then hold down the "MODE" button until Custom Off-Road Plus icon appears.*

Table 30. Ride Modes

ICON	Ride Mode
	Road
	Rain
	Sport
	Off-Road
	Off-Road Plus
 ⁽¹⁾	Custom Off-Road
 ⁽¹⁾	Custom Off-Road Plus

Table 30. Ride Modes

ICON	Ride Mode
	Custom A
 ⁽¹⁾	Custom B
	Ride mode fault
<i>(1) Not available on all models</i>	

Setting Custom Ride Mode

Custom ride modes must be set up before they can be used. To set up a custom ride mode navigate to Ride Modes menu. Settings> Ride Customization> Ride Modes. Select custom ride mode to be set up. Settings from an existing ride mode can be copied and used as a starting point when setting up a custom ride mode. Refer to Table 31 for available selections.

Table 31. Custom Ride Mode Settings

Selection	Result
Engine Map	Sets overall power delivery characteristics in the custom ride mode. Selection will copy engine map characteristics from one of the pre set ride modes.
Engine Braking	Adjusts how much engine braking will be enabled in the custom ride mode.
Throttle Response	Adjusts the intensity of throttle response felt by the rider in the custom ride mode.
Traction Control	The traction control level adjusts how much rear wheel slip and front wheel lift mitigation the system will allow. Selection will copy traction control characteristics from one of the pre set ride modes.
Anti-Lock Braking	Adjusts how much rear wheel lift mitigation and ABS intervention is present within ride mode. Selection will copy ABS characteristics from one of the pre set ride modes.
Suspension Damping ⁽¹⁾	Adjusts suspension damping to the desired level.
Adaptive Ride Height ⁽²⁾	Adjust the timing of when the ARH system will automatically lower or to keep it at ride height.
<i>(1) Available on vehicles equipped with electronic suspension.</i>	
<i>(2) Available on vehicles equipped with ARH.</i>	

ELECTRONIC THROTTLE CONTROL (ETC)

The motorcycle has an Electronic Throttle Control (ETC). Instead of using a mechanical cable connection to the throttle body, this technology uses redundant grip sensors to indicate rider requested throttle position to the Electronic Control Module (ECM). The ECM then regulates proper fuel/air intake and ignition timing based on the rider's actions.

The Electronic Control Module (ECM) monitors the status of the grip sensors, throttle plate actuation and airflow. If Trouble Codes are detected, the ECM disables cruise control, illuminates the check engine lamp and will transition to one of the following modes.

ETC Limited Performance Mode

The rider experiences near-normal operation. The motorcycle operates with provisions to guard against unintended acceleration.

ETC Power Management Mode

The throttle plate actuator returns to an "idle detent" or "limp-home" position, which provides enough torque to achieve speed of about 40 km/h (25 mph). The motorcycle's response to grip sensor input is reduced.

ETC Forced Idle Mode

The throttle plate actuator is forced to a "fast idle" position, which provides enough torque to crawl, but not enough torque to operate at traffic speeds. This results in higher than normal idle speed and no throttle response.

ETC Forced Shut Down Mode

The engine is forced to shut down.

HEATED HAND GRIPS

Models with heated hand grips have a heated hand grip button on the LHCM. See OPERATION > LEFT HAND CONTROL SWITCHES (Page 86)

Push the heated hand grips control button to select the desired setting. The current setting is displayed on the IM as a indicator. There are 4 heat settings ranging from Off to High. Table 32

The hand grips are thermostatically-controlled, providing a constant grip temperature regardless of changes in the outside temperature. To prevent battery drain, heated hand grips can only be used while the engine is running.

Maintaining consistent hand contact with both left and right-hand grips produces the most consistent results. If the hand grips are not producing heat or the IM shows an alert, see a Harley-Davidson dealer.

NOTE

Allow approximately 20 minutes for grips to reach final operating temperature.

Table 32. Heated Hand Grips Settings and Alert





Indicator	Heat Range
	Off
	Low

Table 32. Heated Hand Grips Settings and Alert

Indicator	Heat Range
	Medium
	High
ALERT	
	Alert

USB PORT

⚠ WARNING

Set volume levels and other controls on audio and electronic devices before riding. Distractions can lead to loss of control, resulting in death or serious injury. (00088b)

See Figure 42. The motorcycle has a USB-C port for charging a phone or media device and software update data transfer. Use an interface cable to connect with these devices. The USB-C port is powered and operational when the vehicle is turned on or in accessory mode.

NOTE

USB-C port cannot be used for playing music stored on a device.

Do not leave items connected to the USB-C port unattended.

See Figure 42. USB-C port (1) is located in the Right Hand (RH) cowl (2).

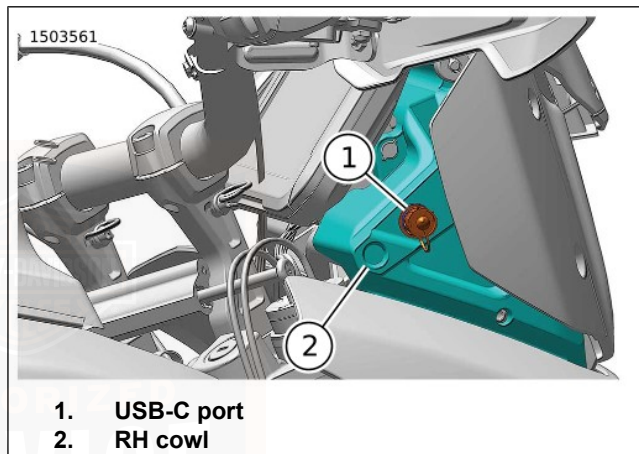

Figure 42. USB-C Port

HEATED GEAR CONNECTOR

The heated gear connectors supply power to selected Harley-Davidson riding apparel.

Figure 43 The heated gear connectors (3) are stored under the seat in the under seat caddy (1). When in use, heated gear connectors must be routed properly to prevent damage.

1. Remove seat. See SERVICE PROCEDURES > SEAT (Page 173).
2. Figure 43 Remove the heated gear connectors (3) from storage location on under seat caddy (1).

NOTE

Do not route the heated gear harness between frame and the seat. Damage to the harness occurs.

3. Figure 44 Route (4) the heated gear wiring harness toward the left side cover (2).
4. Route the wiring harness behind and down the back side of the left side cover (2).
 - a. In this position, the heated gear connectors can stay without damaging the wiring.

NOTE

When the heated gear connectors are not in use, verify that dust caps are installed.

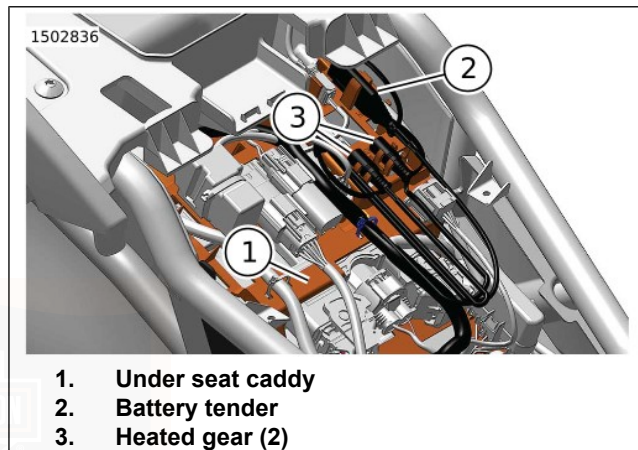

Figure 43. Under Seat

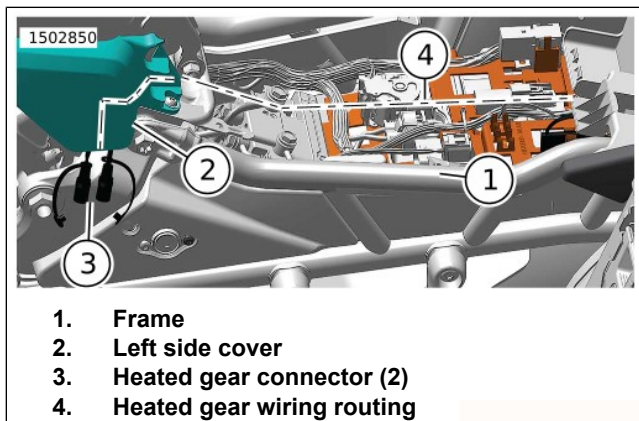

Figure 44. Heated Gear Connector Routing

STARTING THE ENGINE

General

NOTICE

The engine should be allowed to run slowly for 15-30 seconds. This will allow the engine to warm up and let oil reach all surfaces needing lubrication. Failure to comply can result in engine damage. (00563b)

Rolling the throttle before starting the motorcycle is unnecessary.

Starting

⚠ WARNING

Shift transmission to neutral before starting engine to prevent accidental movement, which could result in death or serious injury. (00044a)

1. See OPERATION > RIGHT HAND CONTROL SWITCHES (Page 91). With security fob present, set the OFF/RUN switch to RUN. Do not roll the throttle.

NOTE

The check engine indicator will light when the ignition is turned on. You will hear the fuel pump run for a short time as it pressurizes the fuel system.

2. Squeeze the clutch lever in against the hand grip. Shift transmission to neutral.
3. Press the start switch to start the motorcycle.

NOTE

To allow enhanced lubrication of the engine before start, the engine will crank a number of turns before starting.

4. When the engine has started, you can operate your motorcycle as you normally would after raising the jiffy stand.

NOTE

The ABS and TCS indicators will flash until vehicle is moving approximately 5 km/h (3 mph).

STARTING AFTER TIPOVER

▲ WARNING

If tip occurs, check all controls for proper operation. Restricted control movement can adversely affect the performance of the brakes, clutch or ability to shift, which could result in loss of vehicle control and death or serious injury. (00350a)

NOTE

- If the motorcycle is tipped over, the "BIKE TIPPED" warning indicator appears on the instrument module and four-way flashers activate.
 - The engine cannot start until the tip condition is reset.
 - The ignition must be reset to turn four-way flashers off.
1. Set motorcycle upright.
 2. Cycle the OFF/RUN switch to OFF.
 3. Wait 45 seconds.
 4. Cycle the OFF/RUN switch to RUN.
 5. Push hazard switch to turn four-way flashers off.

STOPPING THE ENGINE

1. Push the off/run switch to off.
2. Remove assigned fob from range.

NOTE

If the engine stalls or stops for any reason, push the off/run switch to off to prevent battery discharge.

CORNERING RIDER SAFETY ENHANCEMENTS

Front Brake Lever

▲ WARNING

Do not position fingers between hand control lever and handlebar grip. Improper hand positioning can impair control lever operation and cause loss of vehicle control, which could result in death or serious injury. (00032a)

See Figure 45. The front brake hand lever (1) controls the front wheel brake. The lever is on the right handlebar. Operate the hand lever with the fingers of the right hand.

Rear Brake Pedal

See Figure 45. The rear brake pedal (2) controls the rear wheel brake. The pedal is on the right side. Operate the rear brake pedal with the right foot.

NOTE

Some models are equipped with a variable height brake pedal.

See Figure 46. To change pedal height, pull pedal outward until pedal can be rotated so opposite side is up.

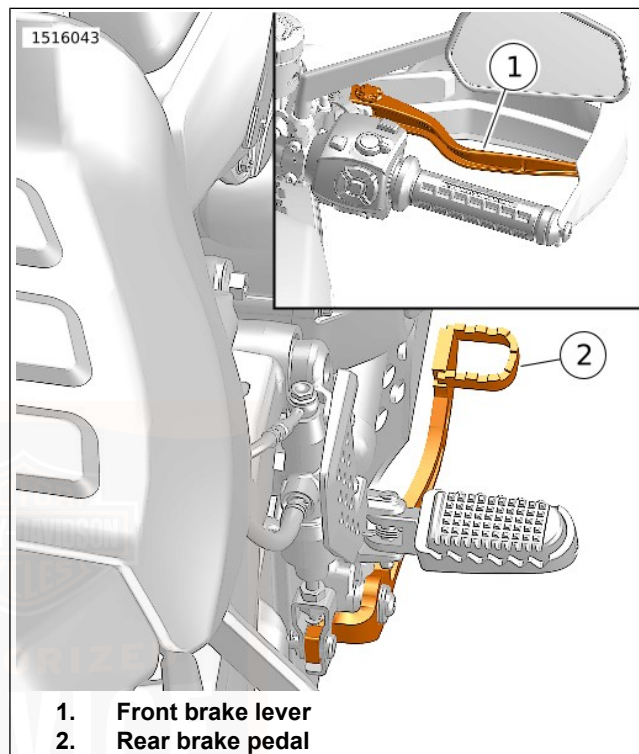

Figure 45. Brake Controls

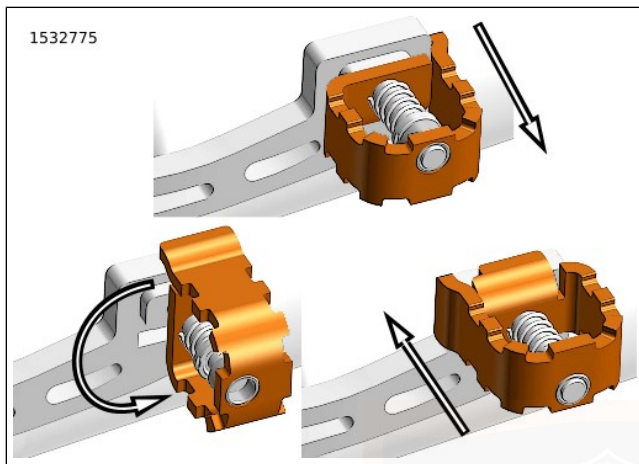

Figure 46. Brake Pedal Height Change

ABS, Cornering Enhanced ABS (C-ABS) and Rear Lift Mitigation (RLM) Functions

ABS is designed to prevent the wheels from locking under braking and helps the rider maintain control when braking in a straight-line, urgent situation. ABS operates independently on front and rear brakes to keep the wheels rolling and prevent uncontrolled wheel lock. The Cornering Enhanced Antilock Braking System (C-ABS) is a variant of ABS that takes into consideration the lean angle of the motorcycle. While

cornering, the available grip for braking is reduced and C-ABS automatically compensates for this reality.

Rear-wheel Lift Mitigation (RLM) utilizes the C-ABS sensors and the six-axis inertial measurement unit (IMU) to manage rear-wheel lift during heavy braking and further balance deceleration and rider control.

Rear wheel ABS and RLM are disabled when the rider selects the Off-Road Plus or Custom Off-Road Plus Ride Modes (see OPERATION > RIDE MODES (Page 100)).

Motorcycles equipped with Cornering Rider Safety Enhancements will display an icon on the IM when the OFF/RUN switch is switched to the RUN position.

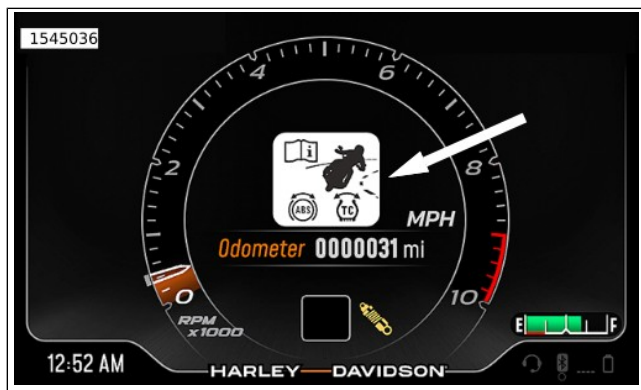

Figure 47. Cornering Rider Safety Enhancements Icon

How ABS Works

The rider recognizes ABS, C-ABS and RLM activation by the slight pulsing sensation in the hand lever or the rear brake pedal. A clicking sound from the ABS module can also be heard. Both are the result of normal operation. Refer to Table 33.

For additional ABS information visit www.harley-davidson.com.

Cornering Enhanced Electronic Linked Braking (C-ELB)

The C-ELB system provides balanced front and rear braking under a wide variety of brake applications. The system provides more linking when the rider is applying heavier braking and reduces or eliminates linking for light braking and low speeds. When linked, applying the front brake lever alone will cause the system to also dynamically apply an amount of braking to the rear. C-ELB takes into account the motorcycle lean angle and will alter the proportioning of brake pressure between the front and rear brakes while cornering in an attempt to improve the ability of the bike to maintain the rider's intended path. C-ELB is disabled when the rider selects the Off-Road Plus or Custom Off-Road Plus Ride Mode (see OPERATION > RIDE MODES (Page 100)).

How To Use ABS

While an advantage in emergency braking, ABS is not a substitute for safe riding. The safest way to stop a motorcycle is using both brakes.

During an emergency stopping situation, maintain pressure on the brakes through all ABS events. Do not modulate or "pump" the brake controls. The wheels do not lock until the end of the stop when motorcycle speed slows to a rate at which ABS is no longer needed.

Hill Hold Control (HHC)

HHC uses brake pressure to keep the motorcycle from rolling downhill when it is stopped on an incline, making it easier to ride away when starting on an incline, such as a hill, a bridge or a parking ramp. The HHC holds brake pressure when activated and prevents the motorcycle from moving after the rider has released the brake controls. The system holds brake pressure until the rider actuates the throttle and clutch to pull away.

NOTE

HHC is not intended to be used as a parking brake.

Activation: The rider activates HHC by applying extra pressure to either the front brake hand lever or the rear brake foot control after the motorcycle has come to a complete stop. If rider brakes very hard to a stop, and holds the brake pressure after stopped, HHC may also set without any added squeeze. A HHC indicator light will illuminate to confirm that the rider has activated HHC and the ABS system will hold brake pressure after the rider releases the brake control.

NOTE

The HHC indicator light will blink if the rider attempts to engage HHC but that action is not available – for example if the sidestand is down on models equipped with a side stand sensor.

Deactivation: HHC is deactivated automatically as the rider begins to pull away from a stop, or if the rider applies and releases either brake control. HHC may deactivate if rider aggressively revs the engine with clutch lever pulled in. HHC will also deactivate if the rider lowers the side stand on models with a side stand sensor (not in all markets) or shifts into neutral on models without a side stand sensor. HHC will deactivate when engine stops running. HHC will deactivate after approximately 10 seconds.

In most situations, the indicator light will flash and the HHC will release if there is no rider action.

The HHC can be disabled and re-enabled by the rider through the settings menu of the IM. Settings> Ride Customization> Hill Hold Control

Tire Pressure Monitoring System (TPMS)

TPMS alerts the rider to low tire air pressure. Maintaining proper tire air pressure is important both for safety and for tire life. The TPMS displays current front and rear tire pressure on the IM and displays an indicator to alert the rider when tire pressure is low, and the pressure should be checked.

ABS: Tires and Wheels

Motorcycles equipped with ABS must always use Harley-Davidson tires and wheels. The ABS monitors the rotational speed of the wheels through individual wheel speed

sensors. Changing to different diameter wheels or different size tires can alter the rotational speed. Different-sized wheels and tires can upset the calibration of the ABS and have an adverse effect on its ability to detect and prevent uncontrolled

wheel lockups. Operating at tire pressures other than those pressures specified can reduce ABS braking performance. Refer to OWNER MANUAL > SPECIFICATIONS (Page 29).

Table 33. ABS Symptoms and Conditions

SYMPTOM	CONDITION
ABS lamp continuously lit	ABS fault detected. See a Harley-Davidson dealer for service.
ABS lamp slow flashing	This indicates a normal self-diagnostics process when the motorcycle is first turned on and the speed is under 5 km/h (3 mph). ABS is not operational until the lamp turns off. If the lamp continues flashing at speeds greater than 5 km/h (3 mph), see a Harley-Davidson dealer for service.
ABS lamp rapid flashing and solid fault alert and traction control indicators	This indicates a potential brake system fault. Apply both front and rear brakes to reduce speed and to stop motorcycle. The brake controls could feel stiff when applied. If this occurs, move the motorcycle to a safe location to stop. Service is required to correct the fault before continuing to ride. See a Harley-Davidson dealer for service.
Pulsing brake lever or pedal during an ABS event	Normal condition.
Clicking sound during an ABS event	Normal condition.
"Surge" sensation while braking	Normal condition. This is most noticeable when braking with one brake (front only or rear only). Result of a reduction in deceleration which can be caused by cracks or bumps in road, engine braking (high engine RPMs causing the rear wheel to slow down), hard braking at slow speeds, and other conditions. This is due to ABS modulating caliper brake pressure to prevent uncontrolled wheel lock.

Table 33. ABS Symptoms and Conditions

SYMPTOM	CONDITION
Temporarily stiff rear brake pedal	Normal condition. Engine braking (high engine RPMs causing the rear wheel to slow down) or down shifting can activate ABS. If applying the rear brake at the same time or immediately after, the ABS may be closing a valve to prevent pressure to the rear brake. This is due to ABS modulating caliper brake pressure to prevent uncontrolled wheel lock.
Tire chirp	Normal condition. Depending on surface, tire can chirp without locking the wheel.
Black mark on pavement	Normal condition. Depending on surface, tire can leave a black mark without locking the wheel.
Wheel lock at low speed	Normal condition. ABS does not activate on front wheel below 5 km/h (3 mph) or on rear wheel below 8 km/h (5 mph).

TRACTION CONTROL

Traction Control (TCS), Cornering Enhanced Traction Control (C-TCS), and Front Lift Mitigation (FLM)

How Cornering Enhanced Traction Control Works

Traction control is designed to keep the rear wheel from “spinning out” when the motorcycle is accelerating, and enhances rider confidence, especially in wet weather.

The Cornering Enhanced Traction Control System (C-TCS) is designed to prevent the rear wheel from excessive spinning

under acceleration when going straight or cornering. C-TCS can improve rider confidence when available traction is compromised by wet weather, a sudden unanticipated change in the surface, or when riding on an unpaved road. The action of C-TCS is also tailored when cornering based on lean angle. Each pre-programmed ride mode has a specific level of C-TCS. In the customizable ride modes the rider can select from three levels of C-TCS intervention.

C-TCS is also designed to support Front-Wheel Lift Mitigation (FLM) to reduce the height and duration of front-wheel lift (wheelie). The height and duration of front-wheel lift is tied to the rider-selected Ride Mode, with Rain being the most-restrictive and Sport/Off Road being the least-restrictive of the standard modes. In Off-Road Plus mode C-TCS will

allow an even greater amount of rear-wheel slip appropriate for off-road use only and fully disables FLM so that an experienced rider may use throttle to lift the front wheel to clear obstacles. Turning off TCS fully disables both TCS and FLM.

In the Off-Road Plus or Custom Off-Road Plus Ride Mode (Refer to: OPERATION > RIDE MODES (Page 100).) TCS is enabled without any cornering adjustments, allowing the rider to take advantage of ruts, banking, and berms to better accelerate at lean.

During start up, the traction-control lamp flashes simultaneously with the ABS lamp, this indicates that both systems are waiting for the vehicle to complete a wheel speed sensor check. The traction control system is operational after startup even during the wheel speed sensor check. The traction control lamp should turn off when the sensor check is complete.

How To Use Traction Control

NOTE

When running a vehicle on a dyno it is advised that traction control be disabled to prevent intervention based on tire speed differences front to rear.

Traction control is automatically enabled at each ignition start cycle. The rider may choose to disable traction control anytime

the vehicle is at a complete stop and the engine is running by pressing and holding the traction control switch for one full second.

Changing to Rain Mode will automatically re-enable TCS, but TCS may be disabled again after Rain Mode has been selected. TCS can be re-activated with the push of a button on the right hand control when the motorcycle is stopped or underway. The traction control indicator will illuminate and remain illuminated to indicate traction control and front lift mitigation are disabled. However, if the TC lamp remains on in conjunction with the fault alert indicator, it means the traction control system has faulted, if this occurs see an authorized Harley-Davidson dealer.

During some fault conditions Traction Control will be enabled with degraded function and cannot be disabled.

The rider may again enable traction control at any time during vehicle operation by pressing and releasing the Traction control switch.

If the traction control lamp begins fast-blinking while riding, it means the traction-control system is intervening.

Cornering Enhanced Drag-Torque Slip Control System (C-DSCS)

Cornering Enhanced Drag-Torque Slip Control (C-DSCS) is designed to reduce excessive rear-wheel slip and help prevent

rear-wheel lock under deceleration, which typically occurs when the rider makes an abrupt down-shift gear change or decelerates on wet or slippery road surfaces.

When C-DSCS detects excessive rear wheel slip under deceleration it will adjust engine torque delivery to better match rear-wheel speed to road speed. The action of DSCS is tailored when cornering, based on detected lean angle.

C-DSCS is disabled in Off-Road Plus and Custom Off-Road Plus (because rear C-ABS is disabled). Additionally, C-DSCS intervention may be diminished when TCS is disabled by the rider.

Intervention of the Drag Torque Slip Control is indicated by fast-blinking of the traction control lamp. However, disabling your Traction Control will not disable Drag Torque Slip Control.

Table 34. Traction Control Symptoms and Conditions

SYMPTOM	CONDITION
Traction control lamp off	Traction control system active.
Traction control lamp continuously lit	Traction control system deactivated by user.
Traction control lamp and security/fault indicator lamp continuously lit	Traction control system faulted.
Traction control lamp flashing	Normal condition. Traction control intervention.
Reduction of throttle response during a traction control event	Normal condition. Traction control intervention.
"Surge" sensation while decelerating	Normal condition. Drag torque slip control intervention.

SHIFTING GEARS

NOTICE

The clutch must be fully disengaged before attempting a gear shift. Failure to fully disengage the clutch can result in equipment damage. (00182a)

Stopped, Engine Off

Slowly pull clutch hand lever in against handlebar grip to fully disengage clutch. Gears do not engage because the transmission shafts are not turning and shifter components are not lined up. Rock the motorcycle backward and forward while lightly pressing the shift lever.

Starting from a Stop

NOTE

*Always start the engine with the transmission in neutral.
Always start forward motion in first gear.*

1. With the engine running and the jiffy stand retracted, pull the clutch hand lever against the handlebar grip to disengage the clutch.
2. Press the gear shift lever down to the end of its travel and release. The transmission is now in first gear.
3. Ease out the clutch lever and at the same time, gradually open the throttle.

Upshift (Acceleration)

See Figure 48. Engage the next higher gear when the motorcycle reaches the shifting speed. Refer to Table 35.

Table 35. Recommended Upshift Speeds

GEAR CHANGE	mph	km/h
First to second	15	25
Second to third	25	40
Third to fourth	35	55
Fourth to fifth	45	70
Fifth to sixth	55	85

1. Close the throttle.

2. Slowly pull clutch hand lever in against handlebar grip to fully disengage clutch.
3. Lift the gear shift lever up to the end of its travel and release.
4. Ease out the clutch lever and gradually open the throttle.
5. Repeat the previous steps to engage remaining gears.

NOTE

- *Disengage the clutch completely before each gear change.*
- *Partially open the throttle so the engine does not drag when the clutch lever is released.*

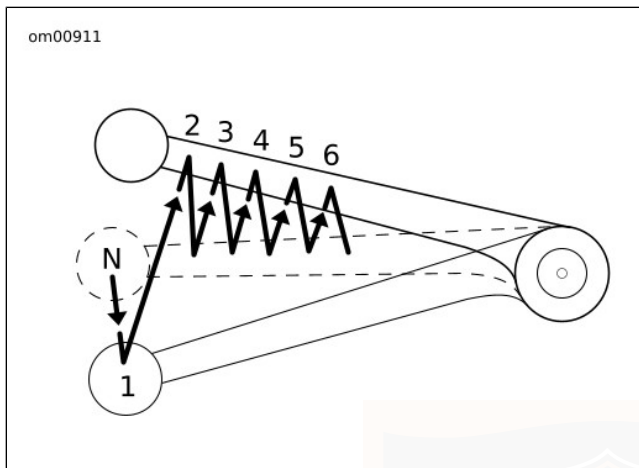

Figure 48. Shifting Sequence: Upshift

Downshift (Deceleration)

▲ WARNING

Do not downshift at speeds higher than those listed. Shifting to lower gears when speed is too high can cause the rear wheel to lose traction and lead to loss of vehicle control, which could result in death or serious injury. (00045b)

See Figure 49. When speed decreases, as when climbing a hill or slowing for a turn, shift to the next lower gear. Refer to Table 36.

Table 36. Recommended Downshift Speeds

GEAR CHANGE	mph	km/h
Sixth to fifth	50	80
Fifth to fourth	40	65
Fourth to third	30	50
Third to second	20	30
Second to first	10	15

NOTE

The shifting points shown in the table are recommendations. Individual shifting points can differ from the table.

1. Close the throttle.
2. Slowly pull clutch hand lever in against handlebar grip to fully disengage clutch.
3. Press the gear shift lever down to the end of its travel and release.
4. Ease out the clutch lever and gradually open the throttle.
5. Repeat the previous steps to engage remaining gears.

NOTE

- Disengage the clutch completely before each gear change.

- Partially open the throttle so the engine does not drag when clutch lever is released.

NOTICE

Shift to neutral before stopping engine. Shifting mechanism can be damaged by shifting gears while engine is stopped. (00183a)

The gear shifter mechanism permits shifting the transmission to neutral from either first or second gear.

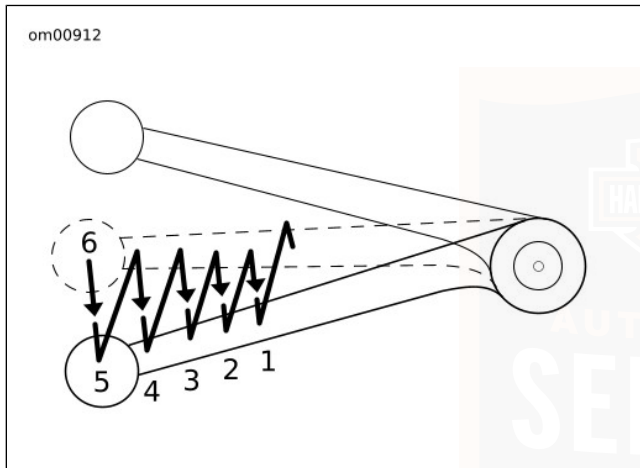

Figure 49. Shifting Sequence: Downshift

WINDSHIELD

NOTICE

Polycarbonate windshields/wind deflectors require proper attention and care to maintain. Failure to maintain polycarbonate properly can result in damage to the windshield/wind deflector. (00483e)

NOTICE

Use only Harley-Davidson recommended products on Harley-Davidson windshields. Do not use harsh chemicals or rain sheeting products, which can cause windshield surface damage, such as dulling or hazing. (00231c)

Raise

- See Figure 50. While holding lever (2) pull trigger (1) until lever can be moved down.
- Carefully move lever down to raise windshield.
- Release trigger to lock windshield in one of four available heights.
- Verify trigger has moved forward to original position.

Lower

1. See Figure 50. While holding lever (2) pull trigger (1) until lever can be moved up.
2. Carefully lift lever up to lower windshield.
3. Release trigger to lock windshield in one of four available heights.
4. Verify trigger has moved forward to original position.

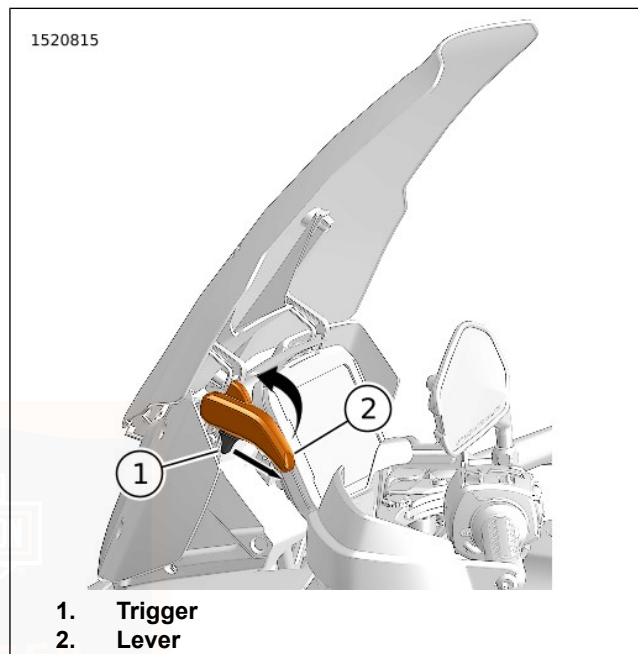

Figure 50. Windshield Height Adjust

NOTES



GENUINE MOTOR PARTS AND ACCESSORIES

Stop at your Harley-Davidson dealer to pick up a copy of the Genuine Motor Parts and Accessories catalog or go to www.harley-davidson.com to view thousands of Genuine Motor Accessories that are available for Harley-Davidson motorcycles.

The website includes the following tools and resources for accessorizing and personalizing your motorcycle.

Online Catalog

The full Genuine Motor Parts and Accessories catalog is available online in Portable Document Format (PDF) format. The catalog includes hundreds of pages of Harley-Davidson accessories and maintenance products.

Shop for Your Bike

Browse through categories of accessories and options available specifically for your motorcycle. View product descriptions, pricing, fitment and online instruction sheets for many of the available products.

CLEANING AND GENERAL CARE

- Harley-Davidson cleaning products are tested extensively for use on motorcycle surfaces. These products are formulated to be compatible with one another. See a Harley-Davidson dealer to purchase recommended cleaning products. Refer to Table 37 and Table 38.
- Care, cleaning and protection of the vehicle surfaces is the responsibility of the owner.
- Clean and protect the cosmetic surfaces on your motorcycle as often as possible to inhibit rust and corrosion.
- Some painted finishes and other surfaces may be scratched if gravel, dirt or grime are rubbed across the surface during washing. Use clean towels and avoid rubbing sediment across gloss finishes.
- Do not use paper towels, cloth diapers or other materials with nylon fibers which can cause fine scratches to surfaces.
- For repair of scratched surfaces, see a Harley-Davidson dealer.

▲ WARNING

Observe warnings on labels of cleaning compounds. Failure to follow warnings could result in death or serious injury. (00076a)

▲ WARNING

Do not wash brake discs with cleaners containing chlorine or silicone. Cleaners containing chlorine and silicone can impair brake function, which could result in death or serious injury. (00077a)

NOTICE

Do not use a pressure washer to clean motorcycle. Using a pressure washer can result in equipment damage. (00489c)

NOTICE

Use of abrasive products or powered buffing equipment will cause permanent cosmetic damage to body panels. Use only recommended products and techniques outlined in this manual to avoid damaging body panels. (00245b)

Cleaning Wheels and Tires

NOTE

Corrosion to wheels is not considered to be a defect in materials or workmanship.

- Wheels can corrode or be cosmetically damaged if they are not properly cleaned, polished and preserved.
- Harley-Davidson recommends that wheels be cared for weekly.
- Keep wheels clean from harsh chemicals, acid-based wheel cleaners, salt, and accumulated brake dust.
- After washing wheels with WHEEL & TIRE CLEANER, use the polish and sealing products according to the type of wheels on your motorcycle. Refer to Table 37.

Radiator

See MAINTENANCE AND LUBRICATION > CLEANING RADIATOR (Page 153) for important information regarding the cleaning of the radiator.

RECOMMENDED CLEANING PRODUCTS

The following products are recommended for Harley-Davidson motorcycles, parts and accessories. Your motorcycle may not have all the components shown in the tables.

Table 37. Recommended Cleaning and Care Products

PRODUCT PART NO.	PURPOSE	FRAME	BODY PANELS	WHEELS	DENIM FINISH	OTHER
BARE METAL POLISH 93600028 (U.S.) 93600083 (Non-U.S.)	Polishes non-clear coated polished aluminum or polished stainless steel surfaces. ⁽¹⁾	As applicable				
BLACK LEATHER REJUVENATOR 93600033 (U.S.) 93600081 (Non-U.S.)	Rejuvenates black leather products so they look brand new.	No	No	No	No	Black leather goods
BUG REMOVER 93600122 (U.S.) 93600140 (Non-U.S.)	Removes bugs from metal, plastic or painted surfaces.	Yes	Yes	Yes	Yes	
CHROME CLEAN & SHINE 93600031 (U.S.) 93600082 (Non-U.S.)	Shines chrome-plated surfaces and cleans brushed aluminum or stainless steel surfaces.	As applicable				
DENIM PAINT CLEANER 93600124 (U.S.) 93600127 (Non-U.S.)	Waterless quick cleaner and detailer.	Yes	Yes	Yes	Yes	
ENGINE BRIGHTENER 93600002 (U.S.) 93600068 (Non-U.S.)	Rejuvenates wrinkle black engine finish.	No	No	No	No	Wrinkle black engines
EVERYDAY DETAILER 93600157 (U.S.) 93600158 (Non-U.S.)	Cleans, shines, brightens and protects in a short amount of time.	Yes	Yes	Yes	No	

Table 37. Recommended Cleaning and Care Products

PRODUCT PART NO.	PURPOSE	FRAME	BODY PANELS	WHEELS	DENIM FINISH	OTHER
GRAPHENE SPRAY COATING 93600166 (U.S.) 93600169 (Non-U.S.)	Provides a protective barrier for glossy paint surfaces and chrome. Repels water and dust.	Yes	Yes	As applicable	No	
GLOSS DETAILER 93600123 (U.S.) 93600125 (Non-U.S.)	Produces high gloss with UV protection. Allows chrome to breathe, unlike wax. Good for windshields.	Yes	Yes	Yes	No	
HARLEY TRAVEL CARE KIT 93600149 (U.S. only)	Travel size cleaning and care products. (Not for use on denim finishes.)	Yes	Yes	Yes	No	
LEATHER PROTECTANT 93600034 (U.S.) 93600080 (Non-U.S.)	Weatherproofs and preserves leather products.	No	No	No	No	Leather goods
QUICK WASH 93600162 (U.S.) 93600171 (Non-U.S.)	A quick wash for a lightly soiled motorcycle. Cleans all surfaces, sheeting action prevents spots.	Yes	Yes	Yes	Yes	
SCRATCH & SWIRL REPAIR 93600155 (U.S.) 93600156 (Non-U.S.)	Removes fine scratches and swirls.	Yes	Yes	No	No	
SEAT, SADDLEBAG & TRIM CLEANER 93600167 (U.S.) 93600170 (Non-U.S.)	Cleans and conditions vinyl, leather and plastic. Use on seats, saddlebags, inner fairings and any other trim.	No	No	No	No	Seats, saddlebags and trim

Table 37. Recommended Cleaning and Care Products

PRODUCT PART NO.	PURPOSE	FRAME	BODY PANELS	WHEELS	DENIM FINISH	OTHER
SPRAY CLEANER & POLISH 93600029 (U.S.) 93600084 (Non-U.S.)	Aerosol quick cleaner and detailer. Reduces static attraction to dust. Works great for removing bugs. ⁽¹⁾	Yes	Yes	Yes	No	
SUNWASH BIKE SOAP 93600129 (U.S.) 93600141 (Non-U.S.)	Thorough washing of all surfaces with a wash mitt. Reduces hard water spots when washing a motorcycle in the sun.	Yes	Yes	Yes	Yes	
WHEEL & TIRE CLEANER 93600121 (U.S.) 93600126 (Non-U.S.)	Removes brake dust and road grime from wheels, tires and whitewalls. Do not use on frames or anodized parts.	No	No	Yes	No	Black-coated exhaust pipes and mufflers

(1) DO NOT use BARE METAL POLISH or SPRAY CLEANER & POLISH on coated aluminum wheels, protective coating will be removed.

Table 38. Recommended Surface Care Products

PRODUCT PART NO.	PURPOSE
BUG EATER SPONGE 93600110	When paired with water and BUG REMOVER, the BUG EATER SPONGE breaks down and dissolves baked on bugs and road grime.
CLEANING BRUSH KIT 94844-10	Brush kit for detailing your motorcycle.
DETAILING SWABS 93600107	Large cotton swabs for cleaning crevices and detailed surfaces.

Table 38. Recommended Surface Care Products

PRODUCT PART NO.	PURPOSE
BIKE WASH BUCKET 93600133	Wash bucket. Includes GRIT GUARD insert.
HOG BLASTER MOTORCYCLE DRYER 94651-09A	Blows a stream of warm dry filtered air. Reduces streaks and water spots.
MICROFIBER APPLICATORS (4 pack) 93600168	Use to apply most wax, coating, sealant, and dressing products.
MICROFIBER DETAILING CLOTH 94663-02	Highly absorbent detailing cloth for polishing and sealing. Contains no nylon fibers.
MICROFIBER DETAILING CLOTHS (3 pack) 93600136	Highly absorbent detailing cloths for polishing and sealing.
MICROFIBER SOFT DRYING TOWEL 93600132	Washable and reusable. Provides a lint- and streak-free drying action for a professional results.
MICROFIBER WASH MITT 93600130	Premium quality microfiber washing mitten. Use with either hand.
WHEEL & SPOKE BRUSH 43078-99	Cone-shaped scrub brush for wheels.

Table 39. Wheel Polish and Sealing Products

WHEELS	PRODUCT	DESCRIPTION
Anodized	GRAPHENE	Cleans surface, removes fine scratches. Provides a breathable sealant against acid, chemicals, salt and brake dust.
	GLOSS DETAILER	Seals and protects against harsh chemicals, salt and other sediments to prevent corrosion.

Table 39. Wheel Polish and Sealing Products

WHEELS	PRODUCT	DESCRIPTION
Chrome	CHROME CLEAN & SHINE	Non-abrasive cleaner to brighten chrome wheels.
	GLOSS DETAILER	Seals and protects against harsh chemicals, salt and other sediments to prevent oxidation.
Polished and bare aluminum or stainless steel	BARE METAL POLISH ⁽¹⁾	Microabrasive polish to refurbish polished wheels. Do not use on chrome.
<i>(1) DO NOT use BARE METAL POLISH on coated aluminum wheels, protective coating will be removed.</i>		

WASHING THE MOTORCYCLE

Use only recommended cleaning and care products. Refer to AFTER RIDING > RECOMMENDED CLEANING PRODUCTS (Page 124).

NOTE

During rinsing and washing, avoid direct spray on electrical components and any luggage or saddlebag sealing areas (if equipped). Avoid spraying water under leather saddlebag covers (if equipped).

Preparation

1. Allow motorcycle to cool before rinsing or washing. Spraying water on hot surfaces can leave water spots and mineral deposits.
2. Rinse the motorcycle from the bottom up.

3. To loosen dried bugs or hardened dirt, allow surfaces to soak under a damp towel.

Cleaning Wheels and Tires

1. Rinse wheel and tire surfaces. Avoid splashing brake dust on chrome or painted parts.
2. Apply WHEEL & TIRE CLEANER. Allow cleaner to set for one minute.
3. Clean the wheel with a BUG EATER SPONGE or WHEEL & SPOKE BRUSH. Thoroughly scrub all brake dust and other sediments off the wheel. Accumulated brake dust can trap moisture and dirt, which leads to wheel corrosion.
4. Rinse well.

Washing the Motorcycle

NOTE

- *During rinsing and washing, avoid direct spray on electrical components and any luggage or saddlebag sealing areas (if equipped). Avoid spraying water under leather saddlebag covers (if equipped).*
 - *Wash vehicle more often when riding off-road or in extreme conditions.*
 - *When washing, be sure to clean fork legs and rear suspension.*
1. If necessary, use BUG REMOVER to remove bug splatters.
 - a. Rinse the affected surfaces during preparation.
 - b. Spray the area with BUG REMOVER.
 - c. Wait one minute while the BUG REMOVER penetrates the bug splatters.
 - d. Use the BUG EATER SPONGE while washing to easily remove bugs.
 2. Prepare the wash.
 - a. Fill a HARLEY WASH BUCKET with clean water.
 - b. Add SUNWASH BIKE SOAP, following the directions on the package.

c. Soak the WASH MITT and/or a BUG EATER SPONGE in the SUNWASH solution.

3. Wash all surfaces starting at the top working down toward the ground.
4. Rinse the motorcycle twice in both directions:
 - a. Rinse from the bottom up.
 - b. Rinse from the top down.

Drying the Motorcycle

1. Dry the surfaces from the top down using a SYNTHETIC DRYING CHAMOIS or a HOG BLASTER MOTORCYCLE DRYER. Avoid using any type of forced air on speakers or other sensitive components.
2. Dampen chamois in clean water and wring out the excess. The chamois is more absorbent when wet.
3. Wipe across the vehicle surface.
4. Repeat as necessary until surface is dry.

Polishing and Sealing

NOTE

If motorcycle has denim finish, skip the Polishing and Sealing procedure.

1. Apply GLAZE POLY SEALANT with a DISPOSABLE DETAILING SOFT CLOTH or MICROFIBER DETAILING CLOTH, following the instructions on the package.
2. Buff with a DISPOSABLE DETAILING SOFT CLOTH.
3. Polish and seal the wheels to prevent corrosion.

WINDSHIELD CARE

NOTICE

Polycarbonate windshields/wind deflectors require proper attention and care to maintain. Failure to maintain polycarbonate properly can result in damage to the windshield/wind deflector. (00483e)

NOTICE

Use only Harley-Davidson recommended products on Harley-Davidson windshields. Do not use harsh chemicals or rain sheeting products, which can cause windshield surface damage, such as dulling or hazing. (00231c)

- Powdered, abrasive or alkaline cleanser can damage windscreen/windshields. Ammonia-based window cleaners cause permanent yellow effects to windshields.
- Do not use gas station windshield cleaner as finish can be damaged.
- Do not use a brush or squeegee as finish can be damaged.

- Do not clean in hot sun or high temperature.

Windshields require special care. However, windshields can be washed with WINDSHIELD CLEANER - INDIVIDUAL WIPES, SUNWASH BIKE SOAP or QUICK WASH when washing the entire motorcycle. Refer to AFTER RIDING > RECOMMENDED CLEANING PRODUCTS (Page 124).

NOTE

- Use BUG REMOVER to soften bug splatters. Wipe clean with a BUG EATER SPONGE.
- Covering windshields with a clean, wet cloth for approximately 15-20 minutes before washing makes dried bug removal easier.

1. Use WINDSHIELD CLEANER to detail windshields.
2. Wipe dry with a clean MICROFIBER DETAILING CLOTH.

NOTE

To minimize swirl marks, clean windshield when the motorcycle is cool and parked in the shade. Faint swirl marks are normal. Swirl marks are more visible on tinted windshields.

LEATHER AND VINYL CARE

NOTICE

Do not use bleach or detergents containing bleach on saddlebags, seats, tank panels or painted surfaces. Doing so can result in equipment damage. (00229a)

Do not use ordinary soap to clean leather or fur. It could dry or remove the oils from the leather.

Leather, vinyl and other synthetic surfaces must be periodically cleaned and treated to maintain its appearance and extend its life. Clean and treat these surfaces once a season or more frequently under adverse conditions.

These surfaces are not designed for long-term exposure to inclement weather. Protect these surfaces with a Harley-Davidson Seat Rain Cover or Motorcycle Storage Cover (sold separately).

1. Vacuum or blow dust off surface.
2. Thoroughly clean surfaces with SEAT, SADDLEBAG & TRIM CLEANER, following directions on the bottle.
3. Allow the material to dry naturally and completely at room temperature before applying other products to the material. Do not use artificial means to dry the material quickly.

4. For leather only, rejuvenate faded black surfaces with BLACK LEATHER REJUVENATOR, and apply LEATHER PROTECTANT to weatherproof and preserve the leather.

NOTE

Many Harley-Davidson accessories and seats are made of either treated or untreated leather or have leather inserts. Natural materials age differently and require different care than man-made materials. Seat covers and panels made of leather gain "character", such as wrinkles, with age. Leather is porous and organic. Each leather product settles into its own distinct form with use. Your leather product matures into its own custom shape and style from the sun, rain and time. This maturing is natural and enhances the custom quality of your Harley-Davidson motorcycle.

EXHAUST CARE

Allow exhaust components to cool before cleaning.

For chrome exhaust surfaces, apply Boot Mark Remover to remove boot marks, melted plastic or asphalt resin. Allow the gel to set for a few minutes, scrape off the melted material, and rinse clean.

For black-coated exhaust surfaces, apply Wheel & Tire Cleaner while motorcycle is wet during washing. Wipe or scrub exhaust surfaces and rinse clean.

NOTE

There is no warranty on exhaust pipes and mufflers with regard to any discoloration. Blueing is caused by tuning characteristics, cam timing, over-heating, and so on. It is not caused by defective manufacturing.

STORING MOTORCYCLE

If the motorcycle will not be operated for several months, take steps to protect the motorcycle. Always protect parts against corrosion, preserve the battery and prevent the build-up of gum and varnish in the fuel before storage.

Make a list of everything you do and fasten it to a handlebar grip. When you take the motorcycle out of storage, this list is your reference/checklist to get your motorcycle in operating condition.

▲ WARNING

Do not store motorcycle with gasoline in tank within the home or garage where open flames, pilot lights, sparks or electric motors are present. Gasoline is extremely flammable and highly explosive, which could result in death or serious injury. (00003a)

1. Fill fuel tank and add a gasoline stabilizer. Use one of the commercially available gasoline stabilizers and follow the manufacturer's instructions.
2. Warm motorcycle to operating temperature. Change oil and turn engine over to circulate the new oil. See MAINTENANCE AND LUBRICATION > CHANGE OIL AND OIL FILTER (Page 140).
3. Prepare battery for storage. See SERVICE PROCEDURES > BATTERY MAINTENANCE (Page 157).
4. To protect the body panels, engine, chassis and wheels from corrosion, follow the cosmetic care procedures before storage. See AFTER RIDING > CLEANING AND GENERAL CARE (Page 123).
5. Cover the motorcycle with a material such as light canvas that breathes. Plastic materials that do not breathe promote condensation and corrosion.

NOTES



MAINTENANCE

⚠ WARNING

Perform the service and maintenance operations as indicated in the regular service interval table. Lack of regular maintenance at the recommended intervals can affect the safe operation of your motorcycle, which could result in death or serious injury. (00010a)

⚠ WARNING

If you operate your motorcycle under adverse conditions (severe cold, extreme heat, very dusty environment, very bad roads, through standing water, etc.), you should perform the regular maintenance intervals more frequently to ensure the safe operation of your motorcycle. Failure to maintain your motorcycle could result in death or serious injury. (00094a)

Service your motorcycle at the regular service intervals. Road conditions like dust, rain or riding styles can require servicing the motorcycle at more frequent intervals. See OWNER MANUAL > SERVICE INTERVALS AND RECORDS (Page 211).

Though some of these procedures can be performed with a minimum of tools, always consult your Harley-Davidson dealer for updates. Remember, your authorized Harley-Davidson

dealer always services your motorcycle with the latest factory approved methods and equipment.

Record each service to maintain the new motorcycle warranty. See SERVICE INTERVALS AND RECORDS > SERVICE RECORDS (Page 211).

BREAK-IN MAINTENANCE

NOTE

The performance of new motorcycle initial service is required to keep your new motorcycle warranty in force and for proper emissions system operation.

After a new motorcycle has been ridden 1,600 km (1000 mi), visit an authorized Harley-Davidson dealer for initial service. Refer to SERVICE INTERVALS AND RECORDS > SERVICE RECORDS (Page 211).

PREPARING THE MOTORCYCLE FOR MAINTENANCE

⚠ WARNING

Be sure to check capacity rating and condition of hoists, slings, chains and cables before use. Exceeding capacity ratings or using lifting devices that are in poor condition can lead to an accident, which could result in death or serious injury. (00466c)

Setting Motorcycle Upright

1. Place motorcycle upright on a level surface or suitable lift, if available.
2. Verify that the motorcycle is level.
3. Secure with tie-downs.

Lifting Motorcycle

NOTE

- See Figure 51. When lifting motorcycle from underneath, always lift directly below crankshaft centerline with wood between motorcycle and lift.
- Always support a motorcycle that is being serviced with blocks or stands.

1. Remove skid plate. See SERVICE PROCEDURES > SKID PLATE (Page 165).
2. Place jack with block of wood below crankshaft centerline.
3. Raise motorcycle to allow servicing.

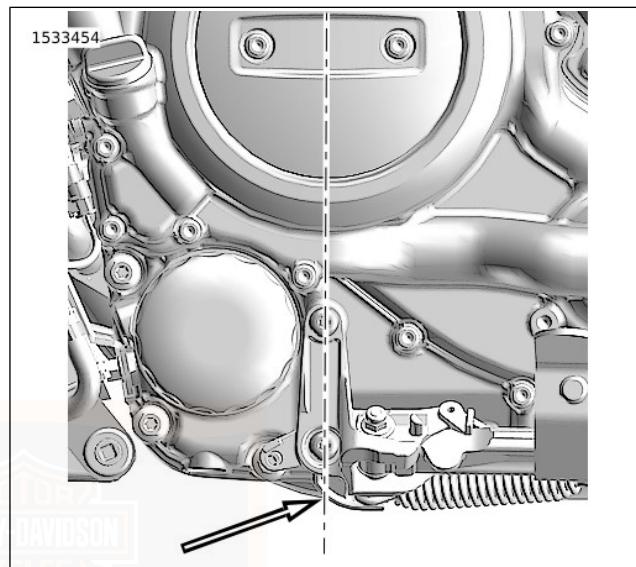

Figure 51. Crankshaft Centerline

DISPOSAL AND RECYCLING

Help protect our environment! Many communities maintain facilities for recycling used fluids, plastics and metals. Dispose of or recycle used oil, lubricants, fuel, coolant, brake fluid and batteries in accordance with local regulations. Many Harley-Davidson parts and accessories are made of plastics and metals which can also be recycled.

ENGINE LUBRICATION

Engine Lubrication

⚠ CAUTION

Prolonged or repeated contact with used motor oil may be harmful to skin and could cause skin cancer. Promptly wash affected areas with soap and water. (00358b)

⚠ CAUTION

If engine oil is swallowed, do not induce vomiting. Contact a physician immediately. In case of contact with eyes, immediately flush with water. Contact a physician if irritation persists. (00357d)

NOTICE

Do not switch lubricant brands indiscriminately because some lubricants interact chemically when mixed. Use of inferior lubricants can damage the engine. (00184a)

Always use the proper grade of oil for the lowest temperature expected before the next scheduled oil change. Refer to Table 40.

This motorcycle was originally equipped with GENUINE HARLEY-DAVIDSON SYN-BLEND MOTORCYCLE OIL 15W50. SYN-BLEND is the preferred oil under normal operating conditions. If operation under extreme cold or heat are expected, refer to Table 40 for alternative choices.

If necessary and SYN-BLEND, SYN3, or HD 360 is not available, add oil certified for diesel engines. Acceptable designations include: CH-4, CI-4 and CJ-4. The preferred viscosities, in descending order are: 20W50, 15W40 and 10W40.

At the first opportunity, see an authorized dealer to change back to 100 percent Harley-Davidson oil.

AUTHORIZED
SERVICE

Table 40. Recommended Engine Oils

TYPE	VISCOSITY	LOWEST AMBIENT TEMPERATURE	COLD-WEATHER STARTS BELOW 50 °F (10 °C)
Harley-Davidson Genuine SYN-BLEND Motorcycle Lubricant	SAE 15W50	Above -1 °C (30.2 °F)	Excellent
Screamin' Eagle SYN3 Full Synthetic Motorcycle Lubricant	SAE 20W50	Above -1 °C (30.2 °F)	Excellent
Genuine Harley-Davidson H-D 360 Motorcycle Oil	SAE 20W50	Above 4 °C (39.2 °F)	Good

Low Temperature Lubrication

Change engine oil often in colder climates. If motorcycle is frequently ridden less than 24 km (15 mi), in ambient temperatures below 16 °C (60.8 °F), reduce oil change intervals to 2,400 km (1,491½ mi).

NOTE

Lower ambient temperatures require more frequent oil changes.

Water vapor is a normal by-product of combustion. During cold-weather operation, some water vapor condenses to liquid form on the cool surfaces inside the engine. In freezing weather, this water becomes slush or ice. If the engine is not warmed to operating temperature, accumulated slush or ice

blocks the oil lines and causes engine damage. Over time, water will accumulate, mix with the engine oil and form a sludge that is harmful to the engine.

If the engine is allowed to warm to normal operating temperature, most of the water evaporates and exits through the crankcase breather.

CHECK ENGINE OIL LEVEL

Notice

Do not allow hot oil level to fall below UPRIGHT FULL mark on dipstick. Doing so can result in equipment damage and/or equipment malfunction. (15911a)

NOTE

Perform engine oil level hot check only with engine oil at normal operating temperature.

1. Check engine oil hot.
 - a. Ride vehicle for more than 5 minutes at mid-range engine speeds or idle for 10 minutes.
 - b. Let engine idle for 30 seconds to 1 minute before shutting down.

NOTE

The only accurate way to check engine oil is in the upright position.

2. Check oil level in upright position.
 - a. Figure 52 Remove engine oil dipstick.
 - b. Wipe off dipstick.
 - c. Insert dipstick and tighten.
 - d. Remove dipstick.
 - e. Figure 53 Oil level must register to the upright full mark (2).

NOTE

Add only enough oil to bring the level to the upright full mark. Do not overfill.

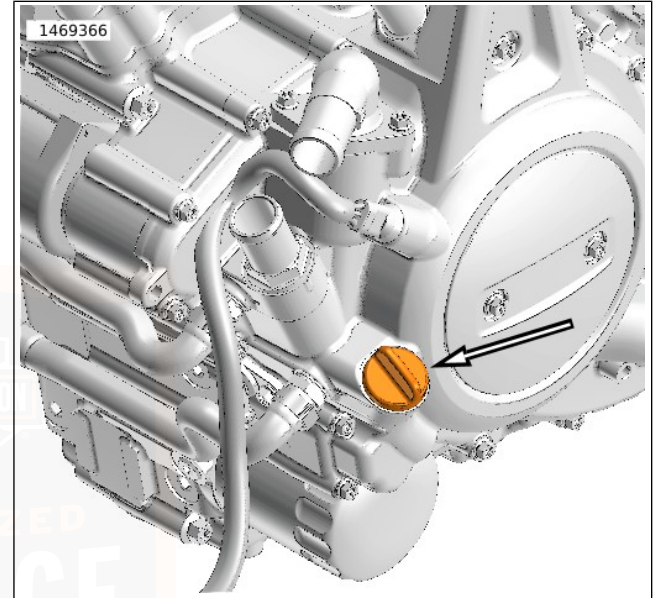

Figure 52. Engine Oil Filler Plug/Dipstick

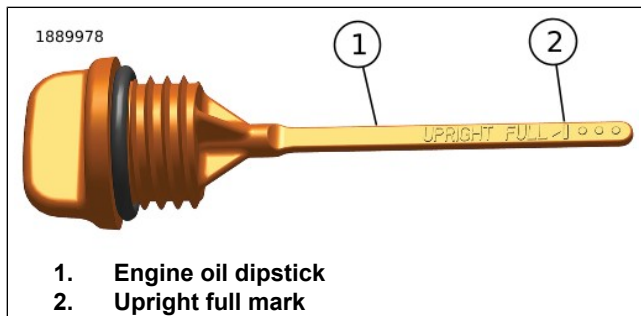

Figure 53. Engine Oil Dipstick (upright full mark)

CHANGE OIL AND OIL FILTER

⚠ WARNING

Be sure that no lubricants or fluids get on tires, wheels or brakes when changing fluid. Traction can be adversely affected, which could result in loss of control of the motorcycle and death or serious injury. (00047d)

NOTICE

Do not switch lubricant brands indiscriminately because some lubricants interact chemically when mixed. Use of inferior lubricants can damage the engine. (00184a)

- Change engine oil at the first 1000 mi (1,600 km) for a new engine. After the initial service, change oil at regular intervals in normal service at warm or moderate temperatures. See SERVICE INTERVALS AND RECORDS > SERVICE RECORDS (Page 211).
 - Change oil at more frequent intervals in cold weather or severe operating conditions. See MAINTENANCE AND LUBRICATION > ENGINE LUBRICATION (Page 137).
1. Run motorcycle until engine is at normal operating temperature. Turn off engine.

2. Rest bike on jiffy stand.

NOTE

Oil must be drained while on jiffy stand to ensure all oil is removed from oil pan.

3. Remove skid plate. See SERVICE PROCEDURES > SKID PLATE (Page 165).
4. Remove filler plug/dipstick.
5. Figure 54 Remove magnetic oil drain plug (2). Allow oil to drain completely.
 - a. Remove and discard O-ring (1).

6. Remove oil filter using special tool. Do **NOT** use air tools.

Special Tool: OIL FILTER WRENCH (HD-52991)

7. Clean oil filter mount flange.

8. Clean any residual oil from crankcase housing.

9. Figure 55 Install **new** oil filter.

a. Lubricate gasket with a thin film of clean engine oil.

b. Fill new oil filter half full with engine oil.

c. Install new oil filter.

d. Hand-tighten oil filter three-quarters of a turn after gasket first contacts filter mounting surface. Do **NOT** use oil filter wrench for installation.

10. Figure 54 Install **new** O-ring (1).

a. Lubricate with clean engine oil.

11. Install magnetic oil drain plug (2). Tighten.

Torque: 20 N·m (15 ft-lbs) *Plug, magnetic oil drain*

12. Add an initial volume of engine oil. Table 41

Table 41. Initial Oil Fill

ITEM	QUANTITY
Engine oil initial fill	2.4 L (2.5 qt)

13. Install filler plug/dipstick.

14. Run engine for 10 seconds.

15. Turn off engine and remove filler plug/dipstick.

NOTE

The sidestand marks on the dipstick are used only for a quick reference when changing oil.

16. See Figure 53. Add only enough oil to bring the level to the add quart mark.

17. Verify proper oil level.

a. Start engine and carefully check for oil leaks around drain plug and oil filter.

b. Check engine oil level. Refer to: MAINTENANCE AND LUBRICATION > CHECK ENGINE OIL LEVEL (Page 138).

NOTE

Engine oil level must be checked at normal operating temperature.

18. Install skid plate. See SERVICE PROCEDURES > SKID PLATE (Page 165).

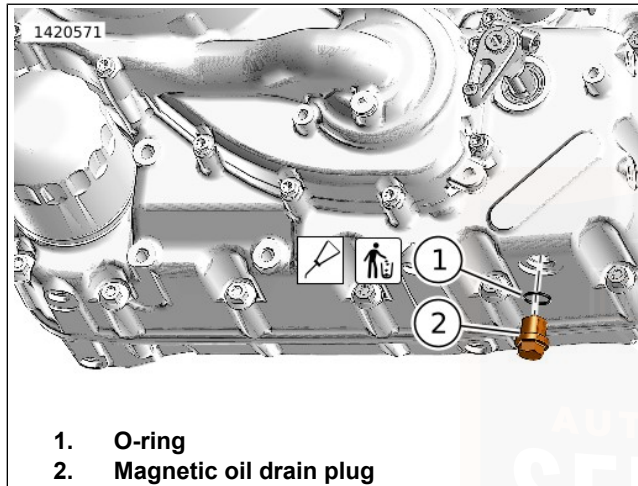

Figure 54. Oil Drain Plug

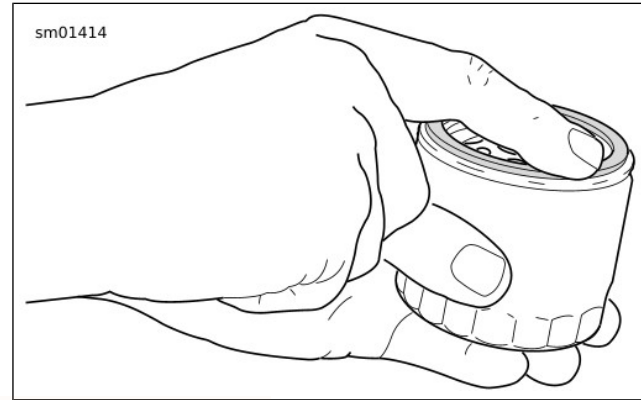

Figure 55. Lubricating New Oil Filter Gasket

OIL COOLER

After the oil filter, the oil is fed into the bottom of the LCOC (layered core oil cooler) mounted to the crankcase on the front right side of the engine. Under heavy load or high rpm operation, heat is transferred from the oil into the coolant. Under light load and cruising conditions, the oil temperature is regulated to the coolant temperature for optimal fuel efficiency and oil quality. Oil exits the top port of the LCOC and is returned into the crankcase.

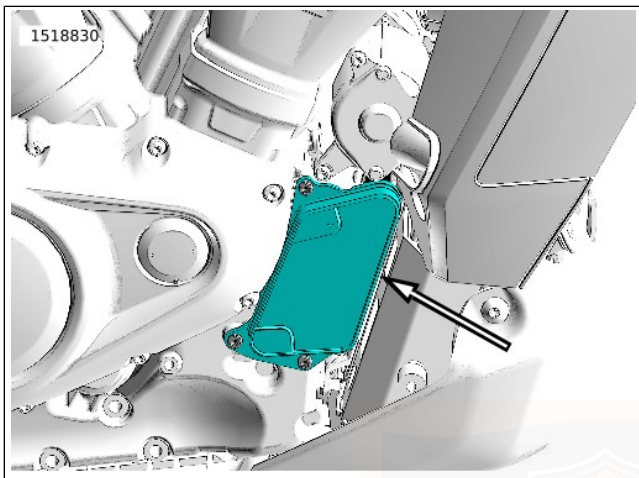

Figure 56. Oil Cooler Location (exhaust system removed for clarity)

INSPECTING BRAKE PADS AND DISCS

Brake Pads

Harley-Davidson has provided your new motorcycle with the optimum brake pad friction material available. It is selected to give the best performance possible under dry, wet and high operating temperature conditions. It exceeds all regulatory requirements currently in effect. However, during some braking

conditions you may experience noise. This is normal for this friction material.

⚠ WARNING

Always replace brake pads in complete sets for correct and safe brake operation. Improper brake operation could result in death or serious injury. (00111a)

1. Check the brake disc as it spins. The disc should run true in the brake caliper.
2. See Figure 57. Measure the thickness of the brake pad friction material.

NOTE

The pads do not necessarily wear evenly. The grooves on the front brake pads are no longer visible when the pads are near the end of service life.

3. Refer to Table 42. If the brake pad friction material is at the minimum thickness or less, replace the pads. Always replace brake pads in pairs. See a Harley-Davidson dealer.

Table 42. Brake Specifications

MINIMUM THICKNESS	mm	in
Front brake pads	0.5	0.020
Rear brake pads	1.0	0.039

Table 42. Brake Specifications

MINIMUM THICKNESS	mm	in
Front brake discs	4.0	0.157
Rear brake disc	4.5	0.177

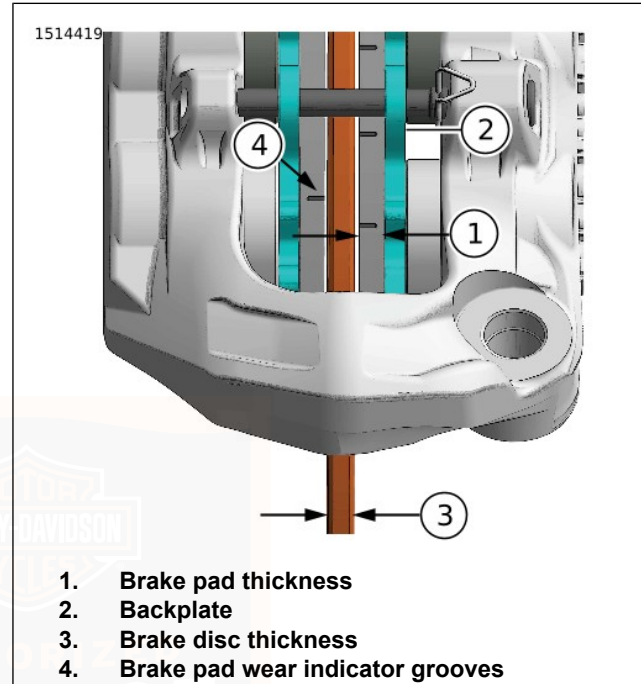

Figure 57. Brake Thickness

Brake Disc

1. Refer to Table 42. Check brake disc thickness and compare to value indicated in table.
2. Replace if necessary. See a Harley-Davidson dealer.

CHECKING SYSTEMS FOR LEAKS OR ABRASIONS

Check all lines and hoses for leaks, damage or abrasions. Refer to SERVICE INTERVALS AND RECORDS > SERVICE RECORDS (Page 211) for the appropriate intervals.

- Fuel system and fuel lines
- Engine cooling system and coolant lines
- Oil cooling system and oil lines
- Brake system and brake lines

CHECKING BRAKE FLUID LEVEL AND CHANGING BRAKE FLUID

NOTE

- *At every service, check moisture content of fluid using DOT 4 BRAKE FLUID MOISTURE TESTER (PART NUMBER: HD-48497-A). Follow the instructions included with tool.*
- *Flush brake system and replace DOT 4 fluid every two years or sooner if brake fluid test shows moisture content is 3% or greater.*

- *Do not add or remove fluid from the brake system to compensate for normal wear. Reservoir volume is adequate to provide fluid to the wear limits of the pads and discs.*
- *Fluid level in reservoir will decrease with brake wear. If fluid level is low, check brake pads and discs for wear. See MAINTENANCE AND LUBRICATION > INSPECTING BRAKE PADS AND DISCS (Page 143).*

⚠ WARNING

Clean reservoir filler cap or cover before removing. Use only DOT 4 brake fluid from a sealed container. Contaminated fluid can adversely affect braking, which could result in death or serious injury. (13720a)

Checking Brake Fluid Level

1. Set motorcycle upright. Verify that the fluid in the reservoir is level. See MAINTENANCE AND LUBRICATION > PREPARING THE MOTORCYCLE FOR MAINTENANCE (Page 135).
2. **Front:** See Figure 58 Check level on side of front brake reservoir. Level must be above minimum mark on side of reservoir.
3. **Rear:** See Figure 59 Check level on side of rear brake reservoir. Level must be above minimum mark on side of reservoir.

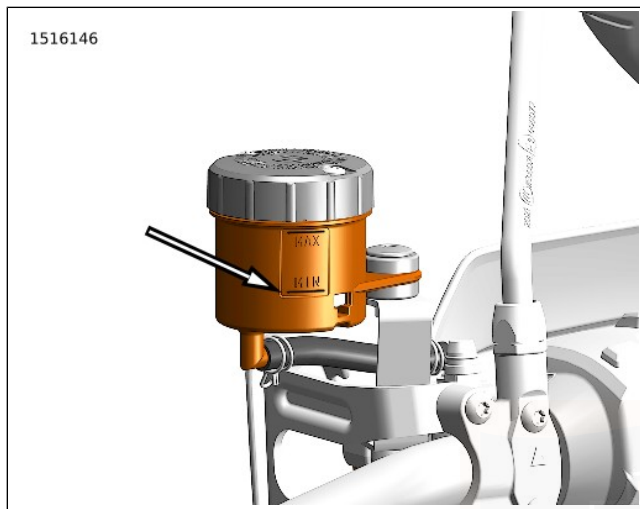

Figure 58. Front Master Cylinder Reservoir MIN Level

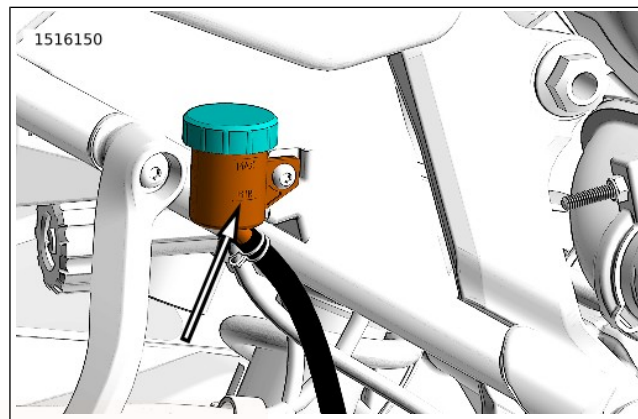

Figure 59. Rear Master Cylinder Reservoir MIN Level

Changing Brake Fluid

▲ WARNING

Contact with DOT 4 brake fluid can have serious health effects. Failure to wear proper skin and eye protection could result in death or serious injury.

- If inhaled: Keep calm, remove to fresh air, seek medical attention.
- If on skin: Remove contaminated clothing. Rinse skin immediately with plenty of water for 15-20 minutes. If irritation develops, seek medical attention.

- **If in eyes: Wash affected eyes for at least 15 minutes under running water with eye lids held open. If irritation develops, seek medical attention.**
- **If swallowed: Rinse mouth and then drink plenty of water. Do not induce vomiting. Contact Poison Control. Immediate medical attention required.**
- **See Safety Data Sheet (SDS) for more details available at sds.harley-davidson.com**

(00240e)

▲ WARNING

DOT 4 brake fluid absorbs moisture from the atmosphere over time, changing the properties of the fluid. Check brake fluid moisture content at every service interval or annually (whichever comes first). Flush and replace the brake fluid every two years, or sooner if moisture content is 3% or greater. Failure to flush and replace fluid can adversely affect braking, which could result in death or serious injury. (06304b)

NOTICE

DOT 4 brake fluid will damage painted and body panel surfaces it comes in contact with. Always use caution and protect surfaces from spills whenever brake work is performed. Failure to comply can result in cosmetic damage. (00239c)

To ensure the brake system is performing to design, check the moisture content of the brake fluid at every service interval or at least annually using a DOT 4 brake fluid moisture tester (part number HD-48497-A or equivalent) following the instructions included with the tool. Flush DOT 4 fluid every 2 years or sooner if the brake system fluid test shows moisture content is 3% or greater.

Harley-Davidson recommends using Harley-Davidson Platinum Label DOT 4 Brake Fluid because of its superior moisture and corrosion inhibiting properties.

CHECKING CLUTCH AND BRAKE CONTROLS

Clutch Hand Lever

The clutch hand lever should move smoothly through its full range.

See a Harley-Davidson dealer for service.

Brake Hand Lever

- The brake hand lever should move smoothly through its full range.
- Verify the brake hand lever has a firm feel when applied.

See a Harley-Davidson dealer for service.

MISCELLANEOUS LUBRICATION

Refer to SERVICE INTERVALS AND RECORDS > SERVICE RECORDS (Page 211) for all maintenance schedules.

NOTE

Use recommended SPECIAL PURPOSE GREASE for steering head bearings. Use a multipurpose chassis grease for other applications.

1. Lubricate clutch control cable with HARLEY LUBE.
2. Lubricate front brake hand lever and clutch control hand lever at recommended service intervals.
3. Lubricate the steering head bearings with SPECIAL PURPOSE GREASE at recommended service intervals.
4. Lubricate the jiffy stand mechanism with SILVER GRADE ANTI-SEIZE.

NOTE

For model specific information regarding the chassis lubrication, see the service manual or a Harley-Davidson dealer.

CHECK DRIVE CHAIN AND SPROCKETS

The drive chain should be checked for worn chain links and correct adjustment. As chains stretch and wear in service,

they will run tighter at one point on the sprocket. Always rotate rear wheel and check adjustment at tightest point of chain.

Chain deflection is critical to increased life of the chain and sprockets. Check deflection as instructed below. Too tight may cause premature wear, damage and breakage. Too loose may cause premature wear, excessive noise and poor transition between acceleration and deceleration.

Inspect Drive Chain

1. Inspect drive chain for:

- Dirt
- Rust
- Binding
- Damaged links
- Damaged O-rings

Measure Drive Chain Deflection

NOTE

Chain deflection can be measured on center stand or on jiffy stand with no rider.

NOTE

Measure chain deflection at center of pins.

1. See Figure 60. Measure chain deflection.

- a. Place transmission in neutral.
- b. Find center point on lower section of chain between transmission sprocket (1) and rear wheel sprocket (2) centers.
- c. Rotate wheel to find tightest point of chain at measure point (3).
- d. Push chain up then pull down to measure amount of deflection (4) in lower portion of chain.
- e. Measure deflection several times during wheel rotation.
- f. Use average of measurements to determine drive chain deflection.
- g. Compare with specifications. Refer to Table 43. If not within specifications, see a Harley-Davidson dealer.

Table 43. Drive Chain Deflection

VEHICLE POSITION	DEFLECTION	
	in	mm
Vehicle on center stand	1.97-2.36	50-60
Vehicle on jiffy stand	1.81-2.20	46-56

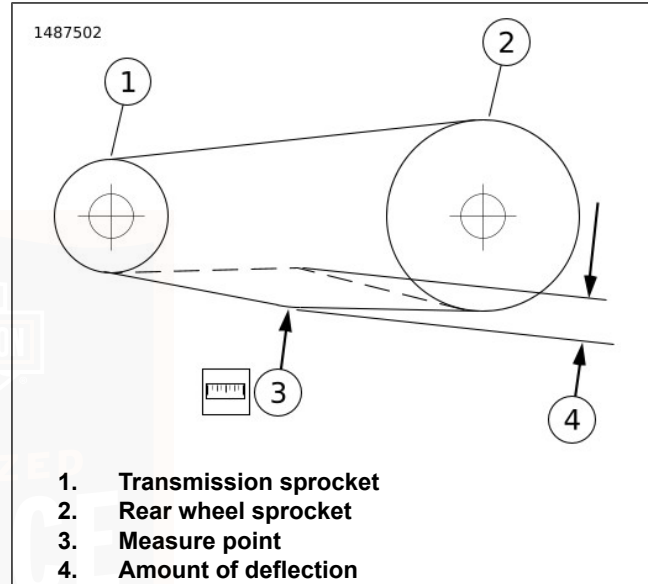

Figure 60. Checking Drive Chain Deflection

Clean and Lubricate

NOTE

Use of the following may result in damage to chain O-rings:

- Steam cleaners
- High-pressure cleaners
- Wire or hard bristle brushes
- Volatile solvents like gasoline and benzene
- Abrasive cleaners
- Chain cleaners or lubricants not specifically designed for O-ring chains

1. Lubricate chain using O-ring chain compatible lubricant per instructions on container.
2. Wipe off excess lubricant.

Inspect Front and Rear Sprockets

See Figure 61. Inspect each tooth of sprocket for:

- Major tooth damage
- Gouges caused by hard objects

If sprockets show major tooth damage or cracks see a Harley-Davidson dealer.

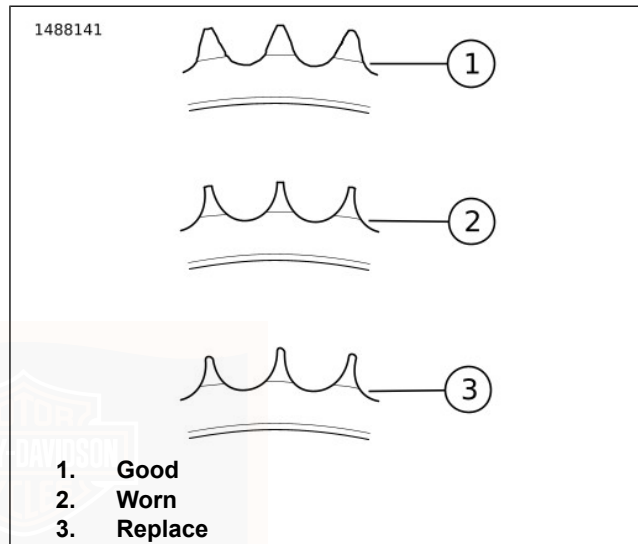

Figure 61. Sprocket Teeth Condition

Inspect Chain Guide

See Figure 62. Inspect chain guide (1) and rail (2) for:

- Damage

- Wear

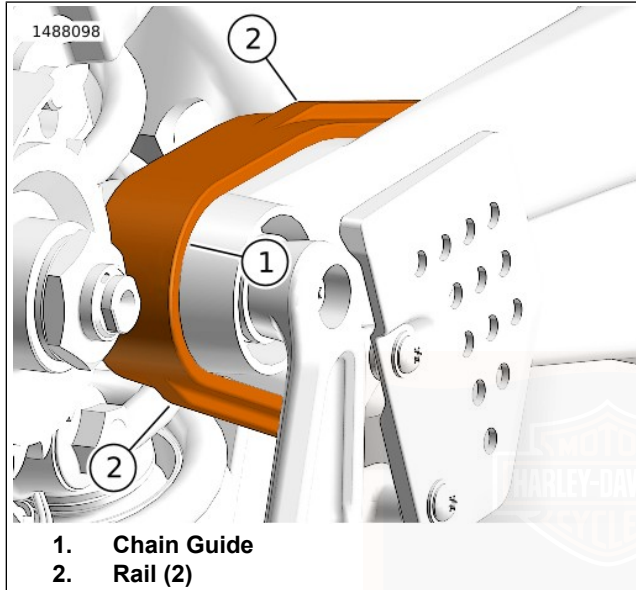

Figure 62. Chain Guide Rails

MECHANICAL CLUTCH

NOTICE

The clutch control cable must be oiled and adjusted periodically to compensate for lining wear. Failure to oil and adjust the clutch control cable can result in equipment damage. (00203c)

NOTE

Perform maintenance more frequently in severe riding conditions. This includes extreme temperatures, dusty environments, mountainous or rough roads, long storage conditions, short runs or heavy stop/go traffic.

Adjust the clutch control cable at specified intervals. Refer to SERVICE INTERVALS AND RECORDS > SERVICE RECORDS (Page 211).

If the clutch slips under load or drags when released, the control cable may need to be adjusted or clutch service may need to be performed. See a Harley-Davidson dealer for service.

COOLANT

General

NOTICE

Use only Genuine Harley-Davidson Extended Life Antifreeze and Coolant. Use of other coolants/mixtures may lead to motorcycle damage. (00179c)

GENUINE HARLEY-DAVIDSON EXTENDED LIFE ANTIFREEZE AND COOLANT is pre-diluted and ready to use full strength. It provides temperature protection to -36.7 °C (-34.0 °F). DO NOT add water.

NOTICE

De-ionized water must be used with the antifreeze in the cooling system. Hard water can cause scale accumulation in water passages which reduces cooling system efficiency, leading to overheating and motorcycle damage. (00195b)

▲ WARNING

Do not loosen or remove pressure cap when cooling system is hot. The cooling system is under pressure and hot coolant and steam can escape from pressure cap, which could cause severe burns. Allow motorcycle to cool before servicing the cooling system. (00091c)

If GENUINE HARLEY-DAVIDSON EXTENDED LIFE ANTIFREEZE AND COOLANT is unavailable, a mixture of de-ionized water and ethylene glycol-based antifreeze may be used. At the first opportunity, change back to GENUINE HARLEY-DAVIDSON EXTENDED LIFE ANTIFREEZE AND COOLANT.

Checking Coolant Level

1. Position vehicle on level ground resting on the jiffy stand.
2. Allow motorcycle to cool.
3. Remove coolant plug/dipstick. See Figure 63.
4. See Figure 64. Check that coolant level is at the "MAX" line (2).

NOTE

If the coolant reservoir is low when the motorcycle is cold, inspect the system for leaks. Repair as needed. Fill system with coolant and purge any trapped air.

5. If level is below "MIN" line (1), add GENUINE HARLEY-DAVIDSON EXTENDED LIFE ANTIFREEZE AND COOLANT until fluid level reaches the "MAX" line (2).
6. Install coolant reservoir plug/dipstick. See Figure 63.

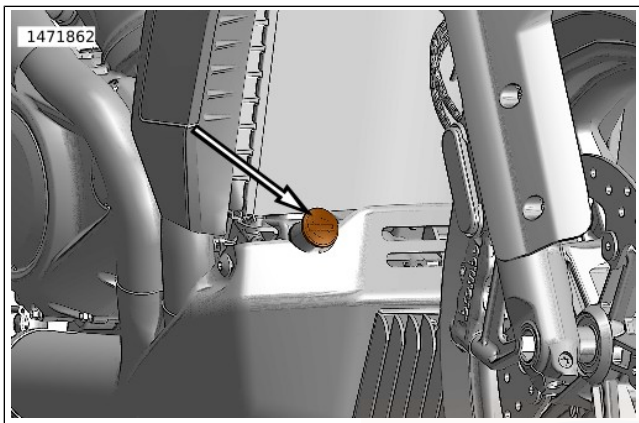

Figure 63. Coolant Filler Cap/Dipstick

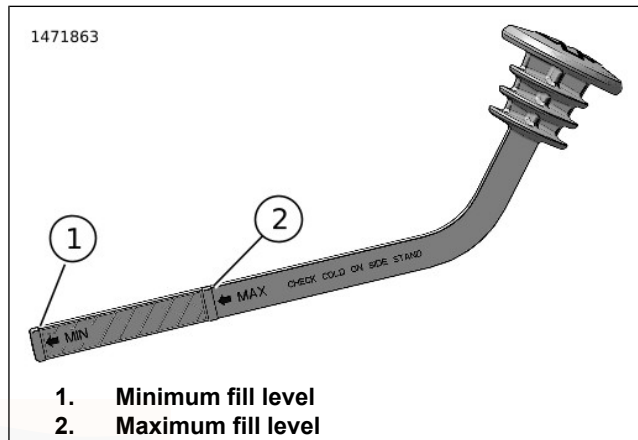

Figure 64. Coolant Filler Cap/Dipstick

Checking Coolant Freeze Point

See a HARLEY-DAVIDSON dealer for coolant freeze point test.

CLEANING RADIATOR

⚠ CAUTION

At operating temperature, radiators and oil coolers contain hot fluids. Contact with a radiator or oil cooler can result in minor or moderate burns. (00141b)

NOTICE

Using a pressure washer to clean radiators or oil coolers can damage cooling fins and reduce airflow. Reduced airflow can lead to overheating, resulting in motorcycle damage. (00056c)

NOTICE

Clean the inlet surface of the radiator regularly. Leaves and other debris can collect on the radiator surface and degrade radiator performance which could lead to overheating and motorcycle damage. (00197d)

1. See Figure 65. Clean debris from radiator fins.

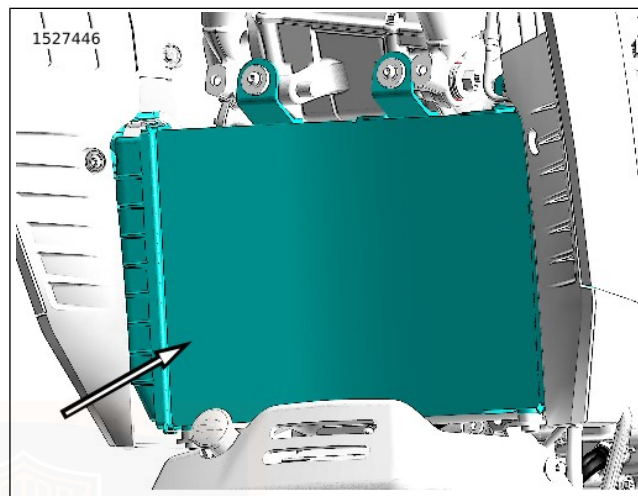

Figure 65. Radiator Fins

REPLACING COOLANT

See a Harley-Davidson dealer for coolant replacement.

AUTHORIZED
SERVICE

MAINTAINING FRONT FORK

⚠ WARNING

Regularly inspect shock absorbers and front forks. Replace leaking, damaged or worn parts that can adversely affect stability and handling, which could result in death or serious injury. (00012a)

Rebound action of the fork will be impaired if the fork oil level is low.

If fork does not appear to be working properly or a significant oil leak should develop, see a Harley-Davidson dealer.

Have a Harley-Davidson dealer service the front forks at proper intervals.

Refer to SERVICE INTERVALS AND RECORDS > SERVICE RECORDS (Page 211) for all maintenance schedules.

ADJUSTING STEERING HEAD BEARINGS

⚠ WARNING

Adjustments to steering head bearings should be performed by a Harley-Davidson dealer. Improperly adjusted bearings can adversely affect handling and stability, which could result in death or serious injury. (00051b)

Refer to SERVICE INTERVALS AND RECORDS > SERVICE RECORDS (Page 211) for all maintenance schedules.

See a Harley-Davidson dealer to adjust the steering head bearings.

SHOCK ABSORBERS

Inspect shock absorbers and rubber bushings for leaks and bushing deterioration at proper intervals.

⚠ WARNING

Shock absorber cannot be serviced. Attempting service can cause an explosion, which could result in death or serious injury. (00602d)

- Do not refill, disassemble, puncture or expose shock to flames.
- Replacement and disposal should only be done by an authorized Harley-Davidson dealer.

SPARK PLUGS

Refer to SERVICE INTERVALS AND RECORDS > SERVICE RECORDS (Page 211) for all maintenance schedules.

See a Harley-Davidson dealer to perform spark plug service.

Do not re-use spark plugs. **New** spark plugs must be installed when serviced.

INSPECTING AIR FILTER

Refer to SERVICE INTERVALS AND RECORDS > SERVICE RECORDS (Page 211) for all maintenance schedules.

NOTE

Perform maintenance more frequently in severe riding conditions. This includes extreme temperatures, dusty

environments, mountainous or rough roads, long storage conditions, short runs, heavy stop/go traffic or poor fuel quality.

See a Harley-Davidson dealer to perform air filter service.

LUBRICATING FUEL CAP LOCK

Lubricate fuel cap lock with HARLEY LUBE.



BATTERY TENDER CONNECTOR

Figure 66 Maintaining the battery between rides and while stored can maintain battery charge and extend the life of the battery. Connect the battery tender connector (2) to a battery tender during storage or to a battery charger if the battery voltage drops below specification. See SERVICE PROCEDURES > BATTERY MAINTENANCE (Page 157).

See SERVICE PROCEDURES > SEAT (Page 173). Remove the seat to access the connector. Remove the connector cap. Connect the battery through the connector to an automatic, constant monitoring battery charger/tender. The connector is compatible with all Harley-Davidson battery tender/chargers.

When removing the tender/charger, replace the connector cap to prevent moisture damage when not in use. Properly stow connector back under seat.

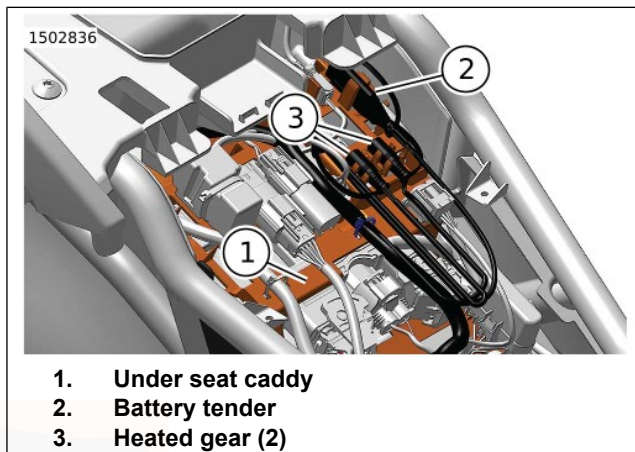

Figure 66. Under Seat

BATTERY MAINTENANCE

Battery Safety

⚠ WARNING

Batteries contain sulfuric acid, which could cause severe burns to eyes and skin. Wear a protective face shield, rubberized gloves and protective clothing when working with batteries. **KEEP BATTERIES AWAY FROM CHILDREN.** (00063a)

⚠ WARNING

Explosive hydrogen gas, which escapes during charging, could cause death or serious injury. Charge battery in a well-ventilated area. Keep open flames, electrical sparks and smoking materials away from battery at all times. KEEP BATTERIES AWAY FROM CHILDREN. (00065a)

⚠ WARNING

Batteries, battery posts, terminals and related accessories contain lead and lead compounds, and other chemicals known to the State of California to cause cancer, and birth defects or other reproductive harm. Wash hands after handling. (00019e)

⚠ WARNING

Never remove warning label from battery. Failure to read and understand all precautions contained in warning, could result in death or serious injury. (00064b)

Absorbed Glass Mat (AGM) Battery Charging Information

The motorcycle has a permanently sealed, maintenance-free Absorbed Glass Mat (AGM) battery design that is superior to conventional flooded lead acid batteries. This battery design will provide many years of dependable service when the

proper battery charging equipment and storage procedures are used. Because of the sealed, nonspillable battery design, an automatic, constant monitoring battery charger/tender with a charging rate of 5 amps or less at less than 14.6 volts is recommended to prevent overcharging conditions that will dry out the cells of the battery. Constant current battery chargers (including trickle chargers) are not recommended and can damage AGM batteries. Do not attempt to open the battery for any reason.

A Harley-Davidson constant monitoring battery charger or tender is recommended to maintain a full charge between rides or when your motorcycle will not be ridden for more than two weeks. The best practice is installing the charger/tender any time the motorcycle is not in use. Harley-Davidson offers a variety of fully automatic charger/tenders (North American and international versions available). These battery charger/tenders include a quick disconnect cable, allowing easy connection to charge the battery without disassembly of the motorcycle.

Lack of regular battery charging or use of constant current battery chargers may void battery warranty.

Cleaning and Inspecting

NOTE

When cleaning battery, clean voltage regulator. Remove debris from between cooling fins and surface of voltage regulator.

Battery top must be clean and dry. Dirt and electrolyte on top of the battery can cause battery to self-discharge.

1. Clean top of battery.
2. Clean cable connectors and battery terminals using a wire brush or fine grit sandpaper to remove any oxidation.
3. Inspect and clean the battery screws, clamps and cables. Check for breakage, loose connections and corrosion.
4. Check the battery posts for melting or damage caused by over-tightening.
5. Inspect the battery for discoloration, a raised top or a warped or distorted case. Any of these conditions indicate that the battery has been frozen, overheated or overcharged.
6. Inspect the battery case for cracks or leaks.

Charging and Storing the Battery

A battery that is left in the motorcycle can either self-discharge or discharge from parasitic loads. Parasitic loads occur from

things like diode leakage and maintaining computer memory. A battery that is removed from the motorcycle can also self-discharge. It is not necessary to remove battery from vehicle for storage.

- Batteries self-discharge at a faster rate at higher ambient temperatures.
- To reduce the self-discharge rate, store battery in a cool, dry place.

An automatic, constant monitoring battery charger/tender with a charging rate of 5 amps or less at less than 14.6 volts is recommended. The use of constant current chargers (including trickle chargers) to charge sealed AGM batteries is not recommended. Any overcharge will cause dry-out and premature battery failure. Never charge a battery without first reviewing the instructions for the charger being used. In addition to the manufacturer's instructions, follow the general safety precautions.

Charge the battery when:

- Motorcycle lights appear dim.
- Electric starter sounds weak.
- Battery has not been used for two weeks or more.

⚠ WARNING

Unplug or turn OFF battery charger before connecting charger cables to battery. Connecting cables with charger ON can cause a spark and battery explosion, which could result in death or serious injury. (00066a)

NOTE

Make sure that the ignition and all electrical accessories are turned off.

Always follow charging instructions supplied with the charger/tender.

1. With battery in the motorcycle.
 - a. Connect battery charger/tender lead to motorcycle battery tender connector. See SERVICE PROCEDURES > BATTERY TENDER CONNECTOR (Page 157).
 - b. When charging is completed turn OFF the charger. Disconnect the motorcycle battery tender connector.
2. With battery removed from motorcycle.
 - a. Place the battery on a level surface.

- b. Connect battery charger/tender lead to battery connector adapter lead supplied with the battery charger/tender.

NOTICE

Do not reverse the charger connections described in the following steps or the charging system of the motorcycle could be damaged. (00214a)

- c. Connect the red battery charger lead to the positive terminal of the battery.
- d. Connect the black battery charger lead to the negative terminal of the battery.
- e. Step away from the battery and turn on the charger.

⚠ WARNING

Unplug or turn OFF battery charger before disconnecting charger cables from battery. Disconnecting clamps with charger ON can cause a spark and battery explosion, which could result in death or serious injury. (00067a)

- f. When charging is completed turn OFF the charger. Disconnect the black battery charger lead. Disconnect the red battery charger lead.

BATTERY REPLACEMENT

Removing Battery

1. Remove skid plate. See SERVICE PROCEDURES > SKID PLATE (Page 165).
2. Figure 67 Remove battery negative cable (2) from battery (1).
3. Remove battery positive cable (3) from battery.
4. Figure 68 Remove starter cable (1) from starter solenoid (2).
5. Figure 69 Remove voltage regulator bracket screws (2).
6. Figure 70 Position voltage regulator bracket (2) out of way.
7. Remove battery (1).

Installing Battery

▲ WARNING

Connect positive (+) battery cable first. If positive (+) cable should contact ground with negative (-) cable connected, the resulting sparks can cause a battery explosion, which could result in death or serious injury. (00068a)

NOTICE

Connect the cables to the correct battery terminals. Failure to do so could result in damage to the motorcycle electrical system. (00215a)

1. Install battery.
2. Figure 69 Position voltage regulator bracket (1).
3. Install voltage regulator bracket screws (3). Tighten.
Torque: 4–7 N·m (35–62 **in-lbs**)
4. Figure 67 Install battery positive cable (3) to battery. Tighten.
Torque: 6.8–7.9 N·m (60–70 **in-lbs**)
5. Install battery negative cable (2) to battery. Tighten.
Torque: 6.8–7.9 N·m (60–70 **in-lbs**)

6. Figure 68 Install starter cable (1) to starter solenoid (2). Tighten.

Torque: 3–4.6 N·m (27–41 in-lbs)

- a. Figure 71 Route starter cable (2) in bracket (1).
7. Install skid plate. See SERVICE PROCEDURES > SKID PLATE (Page 165).

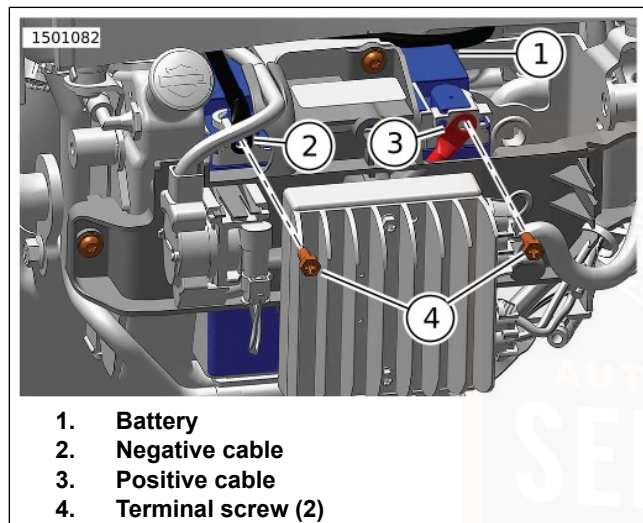

Figure 67. Battery Cables

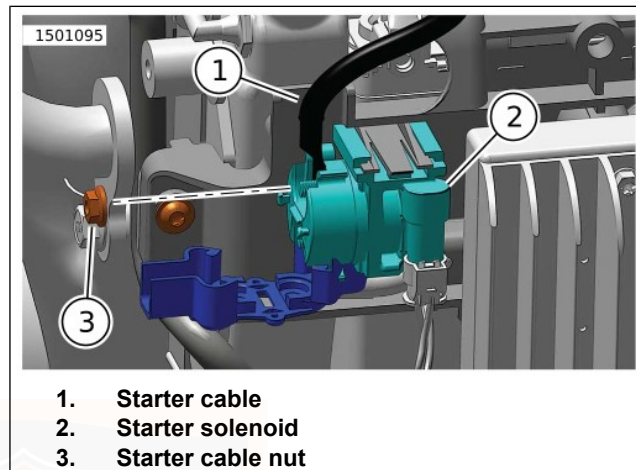

Figure 68. Starter Cable

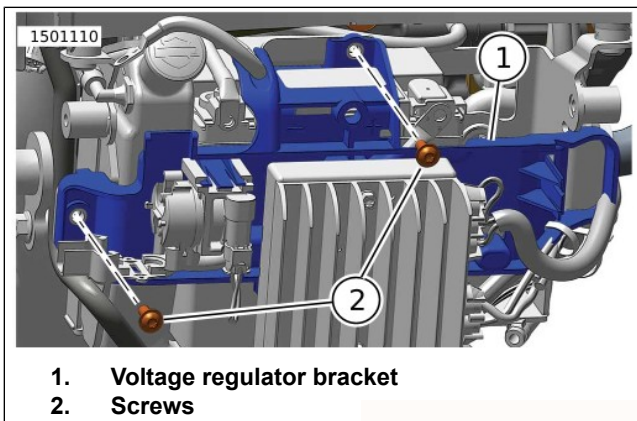

Figure 69. Voltage Regulator Bracket Screws

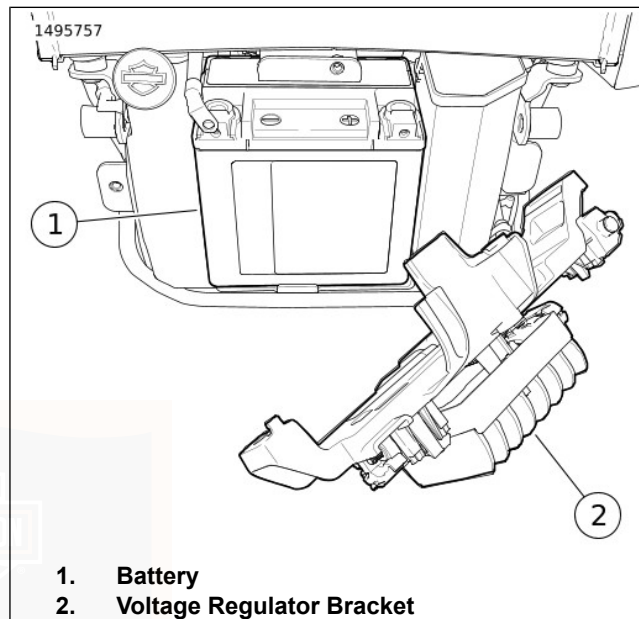
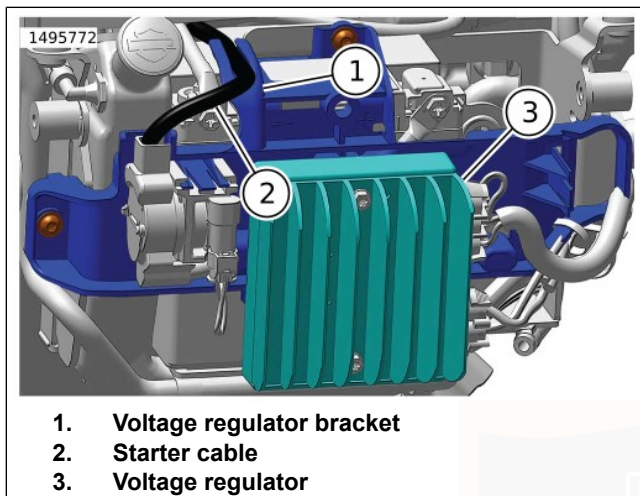

Figure 70. Voltage Regulator Bracket

AUTHORIZED
SERVICE



1. Voltage regulator bracket
2. Starter cable
3. Voltage regulator

Figure 71. Negative Cable Bracket

SIDE COVERS

Figure 72. The procedure for removing the side cover is similar for left and right sides.

Remove

1. Remove fairing. See SERVICE PROCEDURES > FAIRING (Page 168).

2. Remove screw (2) and tip side cover (1) out slightly while lifting up.

Install

1. Align tabs on side cover (1) with mounting holes on vehicle. Secure side cover with screw (2).
2. Tighten screw.
Torque: 0.8–1.2 N·m (7–11 **in-lbs**) Screw, steering head cover
3. Install fairing. See SERVICE PROCEDURES > FAIRING (Page 168).

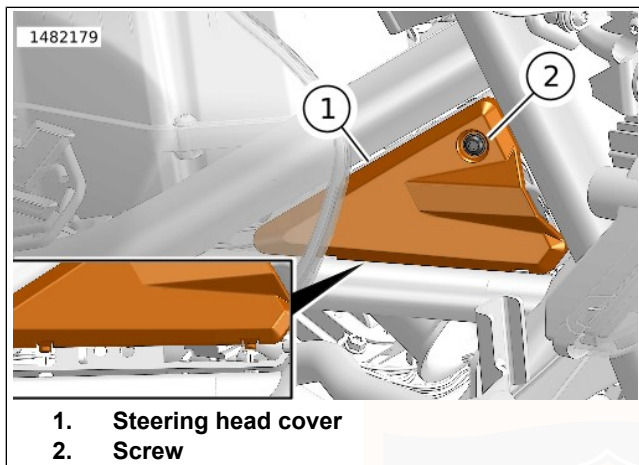

Figure 72. Steering Head Cover (right side shown)

SKID PLATE

One Piece Skid Plate

Remove

1. Figure 73 Remove screws (2).
2. Remove skid plate (1).

Install

1. Figure 74 Verify that grommets (3) and limiters (2) are in place.
2. Figure 73 Position skid plate.
3. Install screws (2). Tighten.
Torque: 19.5–23.8 N·m (14–18 ft-lbs)

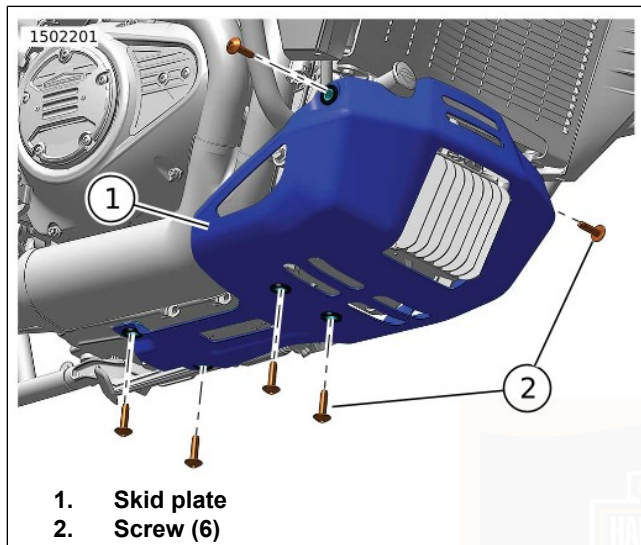

Figure 73. One Piece Skid Plate

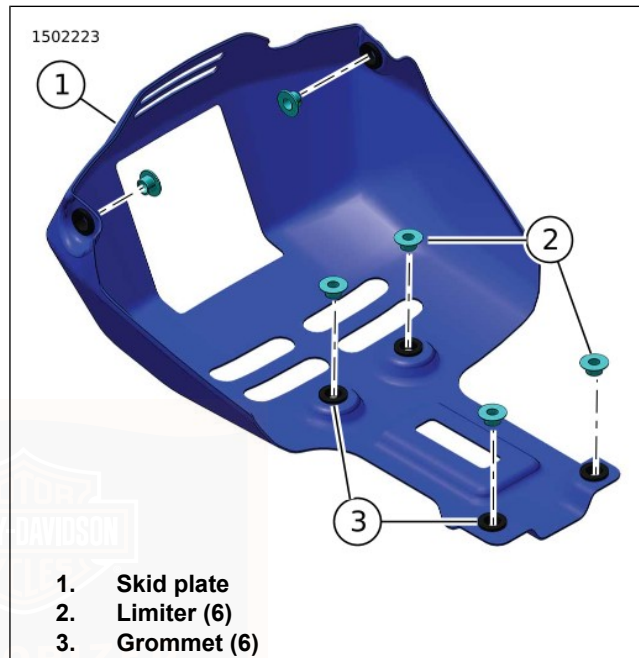

Figure 74. Skid Plate Limiters

Two Piece Skid Plate

Remove Front Skid Plate

1. Figure 75 Remove screws (2)
2. Remove front skid plate (1).

Remove Rear Skid Plate

1. Figure 75 Remove screws (3).
2. Remove rear skid plate (4).

Install Rear Skid Plate

1. Figure 76 Verify that both long and medium limiters (3 & 4) are in place.
2. Figure 75 Position rear skid plate (4).
3. Install screws (3). Hand tighten.

Install Front Skid Plate

1. Figure 76 Verify that short limiters (2) are in place.

2. Figure 75 Position front skid plate (1).
3. Install screws (2). Tighten screws (2 & 3).
Torque: 19.5–23.8 N·m (14–18 ft-lbs)

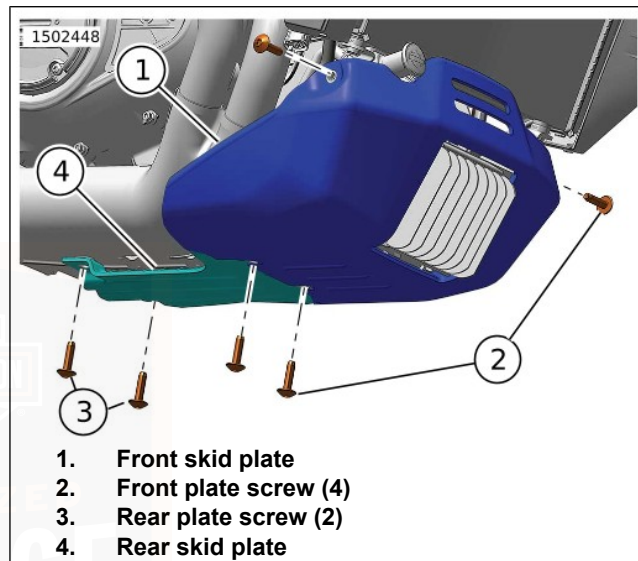

Figure 75. Two Piece Skid Plate

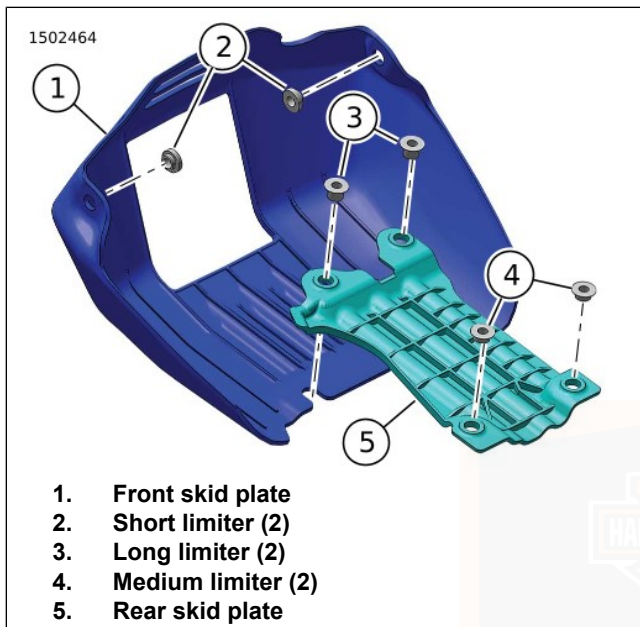

Figure 76. Two Piece Skid Plate - Front and Rear Limiters

FAIRING

Remove

1. See Figure 77. Remove fairing.
 - a. Pull fairing (1) away from the grommets (2).

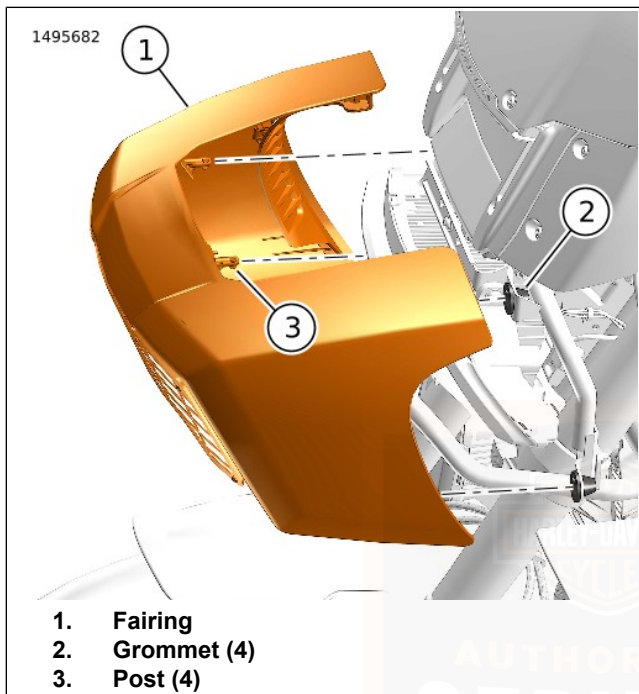

Figure 77. Fairing

Install

1. Figure 77 Install fairing.
 - a. Align fairing posts (3) with grommets (2).
 - b. Push fairing (1) into grommets.

HEADLAMP

⚠ WARNING

The automatic-on headlamp feature provides increased visibility of the rider to other motorists. Be sure headlamp is on at all times. Poor visibility of rider to other motorists can result in death or serious injury. (00030b)

Prepare

1. Check tire pressure. Refer to: BEFORE RIDING > CHECKING TIRE PRESSURE AND INSPECTING TIRES (Page 39).
2. Adjust suspension for intended rider/passenger and intended load. Refer to: BEFORE RIDING > SUSPENSION ADJUSTMENTS (Page 46)..
3. Fill fuel tank or add an equal amount of ballast.

Check Alignment

1. Figure 78 Park motorcycle on a line perpendicular to the wall (1) so front tire is pointed straight forward at the wall.
2. Figure 79 Set motorcycle to the specified distance from bottom center of headlamp (2) to distance to wall (1).
3. Calculate alignment line.
 - a. Turn ignition switch on to activate ARH if equipped.
 - b. With intended rider on motorcycle, measure distance from bottom center of lamp (2) to floor (3).
 - c. Use measured distance and distance shown in table to calculate alignment line. Refer to Table 44.

Table 44. Distance To Subtract From Floor

Model	Distance To Subtract
RA1250, RA1250S	3.4 mm (0.1 in)

4. Figure 78 Draw an alignment line (3) at the calculated distance, on the wall directly in front of motorcycle.
5. Turn **off** any high beam and auxiliary lights to confirm low beam alignment.

6. Verify low beam pattern (2) cut off line is aligned with alignment line (3).
7. Adjust headlamp, if necessary.

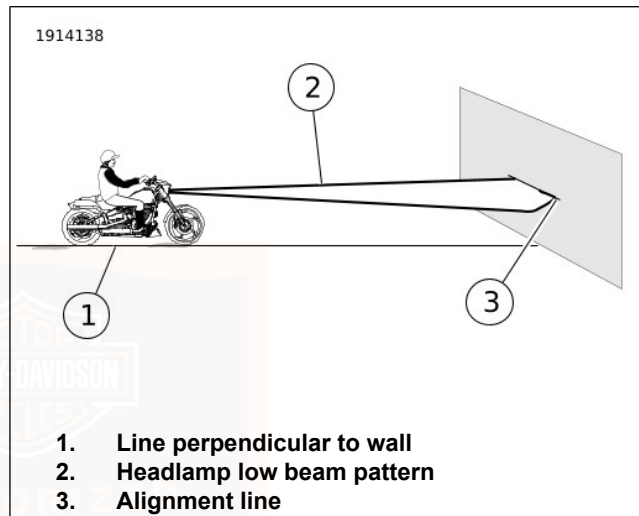

Figure 78. Headlamp Alignment

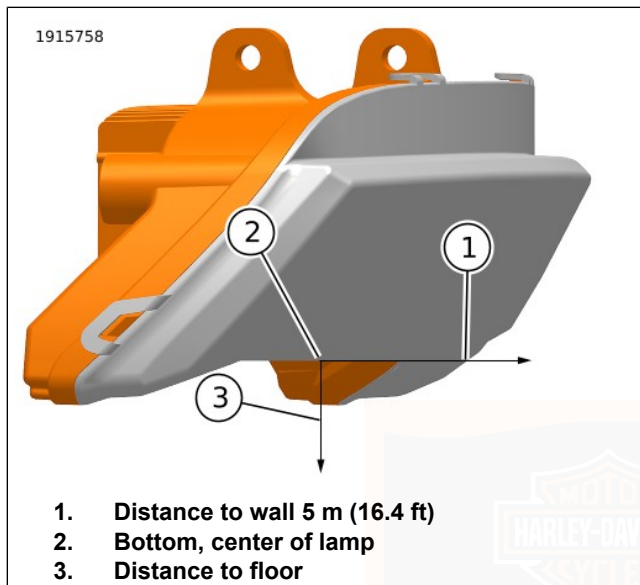

Figure 79. Headlamp Alignment Measuring Points

Adjustment

1. Remove fairing. See SERVICE PROCEDURES > FAIRING (Page 168).
2. Figure 80 Loosen screws (1).

3. Set vertical adjustment.
4. Tighten screws.
Torque: 24–30 N·m (18–22 ft-lbs) *Headlamp screw*
5. Install fairing. See SERVICE PROCEDURES > FAIRING (Page 168).

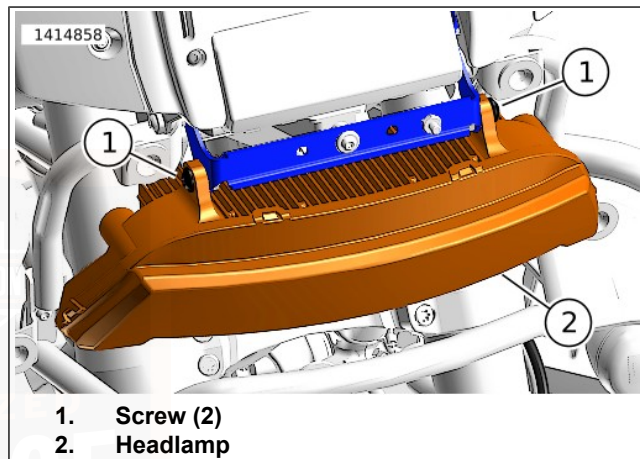

Figure 80. Headlamp Adjustment

Replacing Headlamp

The headlamp contains no replaceable bulbs. The entire assembly must be replaced upon failure. See a Harley-Davidson dealer for service.

BANK ANGLE LAMP

Align headlamp. See SERVICE PROCEDURES > HEADLAMP (Page 169).

Check Bank Angle Lamp Alignment (If equipped)

NOTE

- Vehicle must be in motion to enable full operation of bank angle lighting.
- During the aiming procedure, only the two outer segments of the bank angle lamp illuminate.

Place vehicle in accessory mode. See Accessory Mode in OPERATION > KEYLESS IGNITION (Page 71).

Access settings menu, see OPERATION > INSTRUMENTS (Page 75).

To check bank angle lighting, navigate to aiming ready menu. SETTINGS> RIDE CUSTOMIZATION> BANK LAMP AIMING> AIMING READY.

See Figure 81. If bank angle lights do not align as shown, adjustment is necessary.

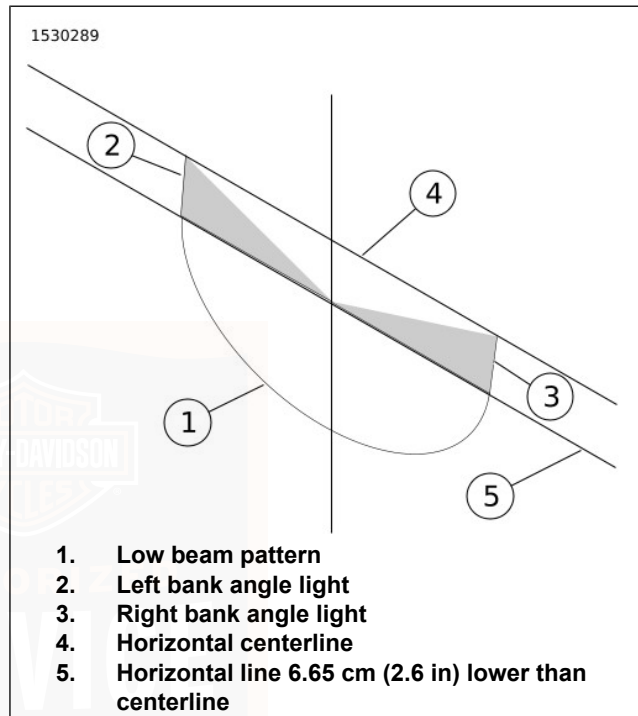

Figure 81. Bank Angle Light Pattern

Adjustment

1. See Figure 82. Loosen bank angle light screws.
2. See Figure 81. Set vertical adjustment.
3. See Figure 82. Tighten screws.

Torque: 8–10 N·m (71–89 **in-lbs**) *Bank angle light screws*

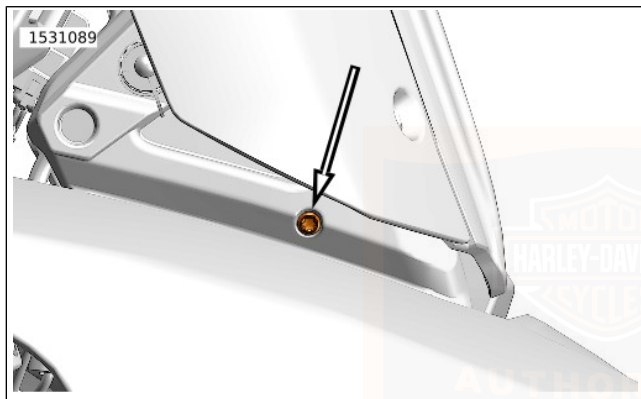

Figure 82. Bank Angle Light Screw (right side shown)

TAIL LAMP BULB REPLACEMENT: LED

The tail lamp is a Light Emitting Diode (LED) assembly. Replace the tail lamp as a unit. See a Harley-Davidson dealer.

TURN SIGNAL BULB REPLACEMENT: LED

The LED turn signal lamp is a sealed assembly. Replace the turn signal lamp as a unit. See a Harley-Davidson dealer.

SEAT

Removal

1. See Figure 83. Insert key in seat lock (2).
2. Turn key to release latch (4).
3. Lift up then back on passenger seat (3) to remove.
4. Lift up then back on rear of rider seat (1) to remove.

Installation

NOTE

Rider seat may be installed in either high position or low position slots to adjust seat height.

1. See Figure 84. Insert tabs (3) of rider seat (1) into high position (4) or low position (5) slots in side covers (2).
2. Lower rear of rider seat (1) into position.

3. See Figure 83. Engage tabs on passenger seat (3) in slots of seat support.
4. Lower rear of passenger seat.
5. Press rear of passenger seat down until a click is heard.
6. Pull up on the seat to verify it is secure.

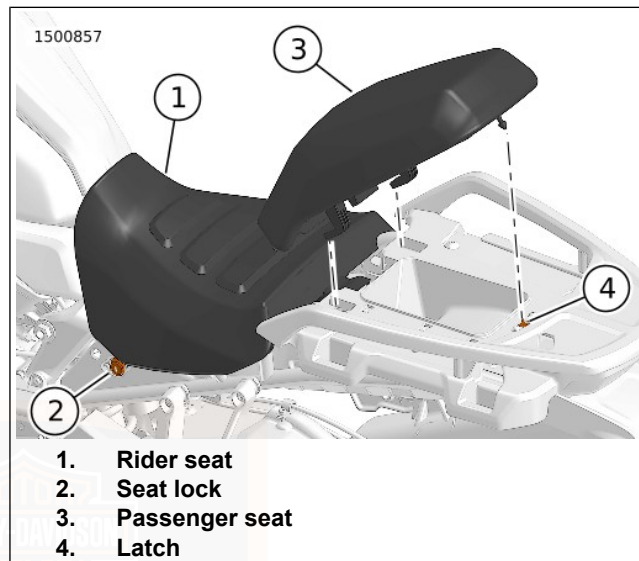

Figure 83. Passenger Seat

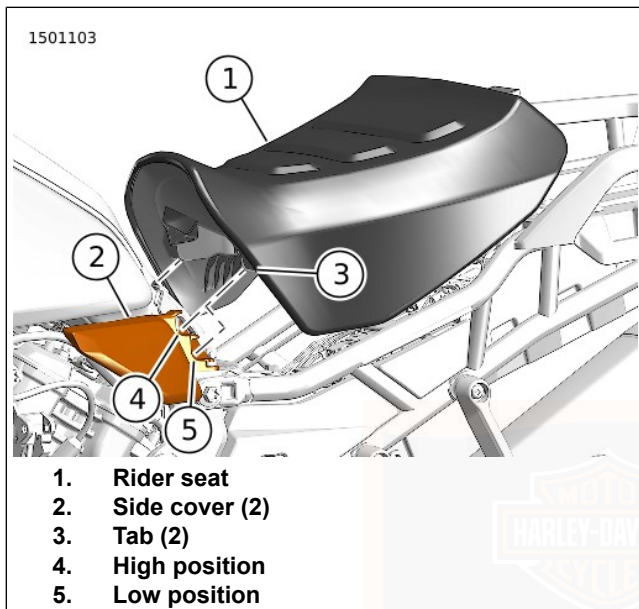

Figure 84. Rider Seat (Two-piece)

FUSES

For electrical problems, see a Harley-Davidson dealer that has the necessary parts and equipment to perform electrical services.

NOTE

- Fuses do not reset.
- Only replace a fuse with a fuse of the same rating.

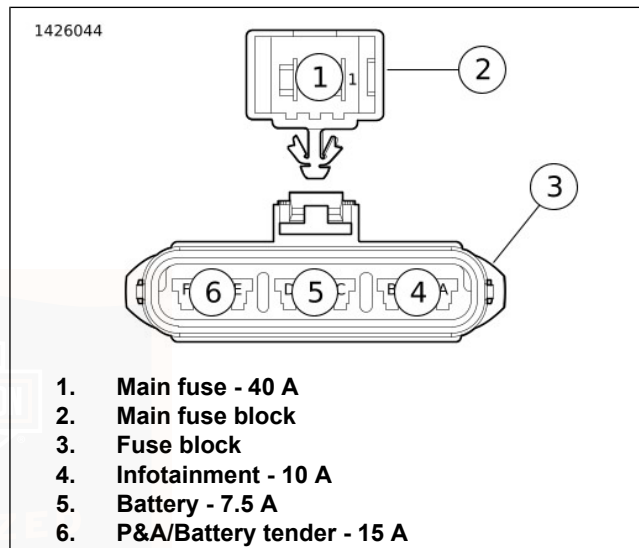

Figure 85. Fuse Blocks and Socket Terminals

Main Fuse

NOTE

The amperage of the main fuse is 40 A.

The main fuse is located under the right side cover. Remove main fuse whenever performing maintenance on the motorcycle.

Remove

1. Set OFF/RUN switch to Off.
2. Remove right steering head cover. See SERVICE PROCEDURES > SIDE COVERS (Page 164).
3. Remove main fuse block (2) from right side caddy (3).
4. Figure 86 Remove main fuse (1).

Install

1. Figure 86 Install main fuse (1).
2. Install main fuse block (2) into right side caddy (3).
3. Install right steering head cover. See SERVICE PROCEDURES > SIDE COVERS (Page 164)

176 Service Procedures

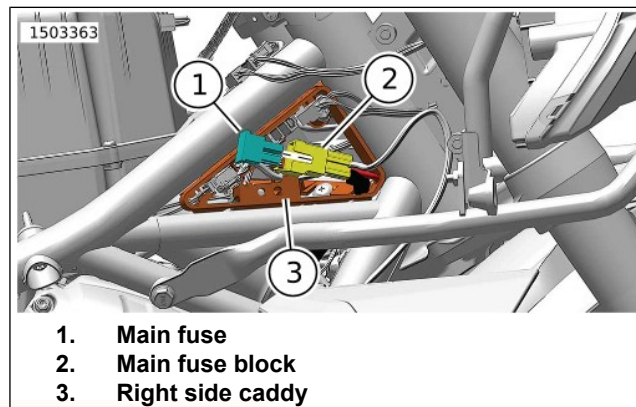

Figure 86. Main Fuse - Location

Fuse Block

Figure 87 The fuse block (1) is located under rider's seat.

Remove

1. Set OFF/RUN switch to Off.
2. Remove seat. See SERVICE PROCEDURES > SEAT (Page 173).
3. Remove cover (2) from fuse block (1).

4. Remove suspect fuse and inspect element.
 - a. Verify that suspected fuse is open.
5. Replace fuse as needed.

Install

1. Figure 87 Install fuse block cover (2).
 - a. Verify tabs snap into fuse block (1).
2. Install seat. See SERVICE PROCEDURES > SEAT (Page 173).

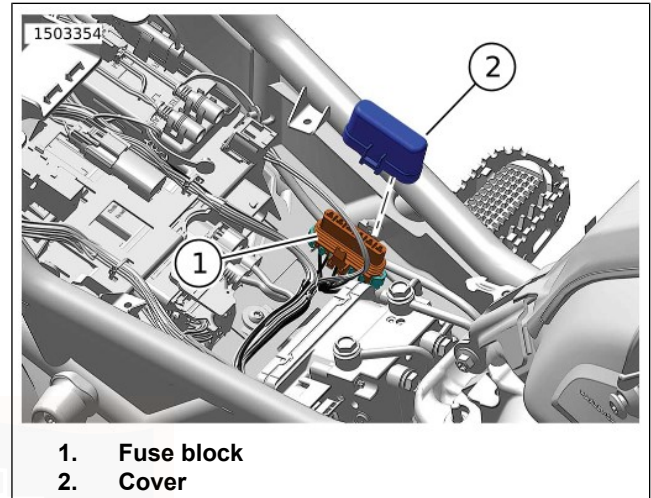

Figure 87. Fuse Block - Location

NOTES



TROUBLESHOOTING: GENERAL

⚠ WARNING

The troubleshooting section of the Owner's Manual is a guide to diagnose problems. Read the service manual before performing any work. Improper repair and/or maintenance could result in death or serious injury. (00080a)

Use the following checklists for troubleshooting. Carefully check each cause because more than one condition can cause trouble.

ENGINE

Starter Does Not Operate or Does Not Turn Engine Over

1. Engine OFF/RUN switch is off.
2. Discharged battery or loose or corroded connections (solenoid chatters).
3. Clutch lever not squeezed against handlebar or transmission not in neutral.
4. Jiffy stand not in retracted position (for models equipped with jiffy stand interlock).
5. Blown fuse.

Engine Turns Over But Does Not Start

1. Fuel tank empty.
2. Fuel filter clogged.
3. Discharged battery or loose or damaged battery terminal connections.
4. Fouled spark plugs.
5. Spark plug cable connections loose or in bad condition and shorting.
6. Loose or corroded wire or cable connection at coil or battery.
7. Fuel pump inoperative.
8. Blown fuse.

Starts Hard

1. Spark plugs in bad condition, have improper gap or are partially fouled.
2. Spark plug cables in bad condition and leaking.
3. Battery nearly discharged.
4. Loose wire or cable connection at one of the battery terminals or at coil.
5. Engine oil too heavy (cold weather).

6. Fuel tank vent plugged or fuel line closed off, restricting fuel flow.
7. Water or dirt in fuel system or filter.
8. Fuel pump inoperative.

Starts But Runs Irregularly or Misses

1. Spark plugs in bad condition or partially fouled.
2. Spark plug cables in bad condition and leaking.
3. Spark plug gap too close or too wide.
4. Battery nearly discharged.
5. Damaged wire or loose connection at battery terminals or coils.
6. Intermittent short circuit due to damaged wire insulation.
7. Water or dirt in fuel system or filter.
8. Fuel vent system plugged. See dealer.
9. One or more injectors fouled.

A Spark Plug Fouls Repeatedly

1. Fuel mixture too rich.
2. Incorrect spark plug for service

Pre-ignition or Detonation (Knocks or Pings)

1. Incorrect fuel.
2. Incorrect spark plug for service

Overheats

1. Low coolant level.
2. Insufficient oil supply or oil not circulating.
3. Heavy carbon deposit from lugging engine. See dealer.
4. Insufficient air flow through radiator during extended periods of idling.

Excessive Vibration

1. Rear fork pivot shaft loose. See dealer.
2. Drive chain or links tight as a result of insufficient lubrication.
3. Damaged frame. See dealer.
4. Wheels and/or tires damaged. See dealer.
5. Vehicle not properly aligned. See dealer.

Engine Oil Not Circulating (Oil Pressure Indicator Lit)

1. Insufficient or diluted oil supply.

2. Grounded oil signal switch wire or faulty signal switch. See dealer.
3. Oil pump problem. See dealer.

TRANSMISSION

Transmission Shifts Hard

1. Clutch controls or clutch cable improperly adjusted. See dealer.
2. Bent shifter rod. See dealer.

Transmission Jumps Out of Gear

1. Worn shifter dogs in transmission. See dealer.

Clutch Slips

1. Clutch controls or clutch cable improperly adjusted. See dealer.
2. Worn friction discs. See dealer.
3. Insufficient clutch spring tension. See dealer.

Clutch Drags or Does Not Release

1. Clutch controls or clutch cable improperly adjusted. See dealer.
2. Clutch discs warped. See dealer.

Clutch Chatters

1. Friction discs or steel discs worn or warped. See dealer.

COOLING SYSTEM

Overheats

1. Low coolant level or improper coolant.
2. Cooling fans not operating.
3. Air flow through the radiator is obstructed.
4. Blocked coolant passages.
5. Temperature gauge malfunction.
6. Radiator cap problem.
7. Thermostat malfunction.

ELECTRICAL SYSTEM

Alternator Does Not Charge

1. Regulator not grounded. See dealer.
2. Engine ground wire loose or damaged. See dealer.
3. Loose or damaged wires in charging circuit. See dealer.

Alternator Charge Rate is Below Normal

1. Weak battery.

2. Excessive use of add-on accessories.
3. Loose or corroded connections.
4. Extensive periods of idling or low speed riding.

BRAKES

Brakes Do Not Hold Normally

1. Master cylinder low on fluid. See dealer.
2. Brake line contains air bubbles. See dealer.
3. Master or wheel cylinder piston worn. See dealer.
4. Brake pads contaminated with grease or oil. See dealer.
5. Brake pads badly worn. See dealer.
6. Brake disc badly worn or warped. See dealer.
7. Brake fades because of heat build up. Excessive braking or brake pads dragging. See dealer.
8. Brake drags. See dealer.



WARRANTY AND MAINTENANCE

This owner's manual contains your new motorcycle limited warranty and your owner's maintenance record.

It is your responsibility as the owner to follow the maintenance schedule at the mileage intervals as specified in the owner's manual. All of the specified maintenance services must be performed on schedule to keep your limited warranty valid.

Some countries, states or other locations may require all regular maintenance and service work to be done by an authorized Harley-Davidson dealer for your limited warranty to remain in effect. Check with your authorized Harley-Davidson dealer for local requirements.

1. Make an appointment with a Harley-Davidson dealer for inspection and service prior to the first 1,600 km (1000 mi), and as soon as possible after any issue arises.
2. Bring this owner's manual with you when you visit your authorized Harley-Davidson dealer to have your motorcycle inspected and serviced.
3. Have the dealer technician sign the maintenance record in the owner's manual at the proper mileage interval. These records should be retained by the owner as proof of proper maintenance.
4. Keep receipts covering any parts, service or maintenance performed.

These records should be transferred to each subsequent owner.

Use only Harley-Davidson approved parts and accessories that have been designed, tested and approved for your model and model year motorcycle.

Use of aftermarket performance parts may void all or parts of your limited warranty. See an authorized Harley-Davidson dealer for details.

Harley-Davidson authorized dealerships are independently owned and operated and may sell and install parts and accessories that are not manufactured or approved by Harley-Davidson for use on your motorcycle. Therefore, you should understand that Harley-Davidson is not and cannot be responsible for the quality, suitability, or safety of any non-Harley-Davidson part, accessory or design modification, including labor, which may be sold and/or installed by authorized Harley-Davidson dealerships.

KEEPING IT ALL HARLEY-DAVIDSON

Genuine Harley-Davidson parts are engineered and tested specifically for use on your motorcycle. Insist that your authorized Harley-Davidson dealer uses only genuine Harley-Davidson replacement parts and accessories to keep your Harley-Davidson motorcycle and its limited warranty intact. Not all Harley-Davidson parts and accessories are appropriate for your model or model year motorcycle.

NOTICE

It is possible to overload the vehicle's charging system by adding too many electrical accessories. If the combined electrical accessories operating at any one time consume more electrical current than the vehicle's charging system can produce, the electrical consumption can discharge the battery and cause damage to the vehicle's electrical system. (00211d)

NOTE

Installing off-road or competition parts to enhance performance may void all or parts of your limited warranty. See the Harley-Davidson Motorcycle Limited Warranty in this owner's manual or an authorized Harley-Davidson dealer for details.

CALIFORNIA AND SELECT INTERNATIONAL MARKETS EVAPORATIVE EMISSION CONTROLS

All new Harley-Davidson motorcycles sold in the State of California and select international markets have an evaporative emission control system. This system is designed to meet CARB and local regulations in effect at the time of manufacture.

The system requires a small amount of maintenance. Periodically inspect system to verify that hoses are properly routed, not kinked or blocked and that all fittings are secure. Periodically check mounting hardware for tightness.

184 Warranties and Responsibilities

EPA NOISE REGULATIONS IN THE UNITED STATES

EPA noise regulations require that the following statements be included in the Owner's Manual.

EPA Regulations

TAMPERING WITH NOISE CONTROL SYSTEM PROHIBITED: Federal law prohibits the following acts or the causing thereof: (1) The removal or rendering inoperative by any person other than for purposes of maintenance, repair, or replacement of any device or element of design incorporated into any new vehicle for the purpose of noise control prior to its sale or delivery to the ultimate purchaser or while it is in use, or (2) the use of the vehicle after such device or element of design has been removed or rendered inoperative by any person.

AMONG THOSE ACTS PRESUMED TO CONSTITUTE TAMPERING ARE THE FOLLOWING:

1. Replacing the muffler(s) and/or the entire exhaust system with parts not certified to be noise legal for street use.
2. Removing or modifying the muffler internal baffles in any way.
3. Replacing the air intake/cleaner assembly with one not certified to be noise legal for street use.

4. Modifying the air intake/cleaner assembly in such a way as to make the vehicle no longer noise legal for street use.

Harley-Davidson recommends that any and all noise related maintenance be done by an authorized Harley-Davidson dealer using Genuine Harley-Davidson parts.

WARRANTY/SERVICE INFORMATION

Any authorized Harley-Davidson dealer may provide warranty repair work on your motorcycle. The fact that an authorized Harley-Davidson dealership performs warranty repairs does not create an agency relationship between Harley-Davidson and the authorized dealership. If you have any questions regarding warranty obligations contact your authorized Harley-Davidson dealer.

For normal service work or warranty work under the above conditions, you may obtain the name and location of your nearest U.S. authorized Harley-Davidson dealer by calling 1-800-258-2464 (U.S. only). To find dealers worldwide, see www.harley-davidson.com.

REPORTING SAFETY DEFECTS IN THE UNITED STATES

Safety defects must be reported to the National Highway Traffic Safety Administration (NHTSA) and Harley-Davidson.

NHTSA Statement

If you believe that your motorcycle has a defect which could cause a crash or could cause injury or death, you should immediately inform the National Highway Traffic Safety Administration (NHTSA) in addition to notifying Harley-Davidson.

If NHTSA receives similar complaints, it may open an investigation, and if it finds that a safety defect exists in a group of motorcycles, it may order a recall and remedy campaign. However, NHTSA cannot become involved in individual problems between you, your authorized Harley-Davidson dealer, or Harley-Davidson.

You can contact NHTSA through the following means. Additional information about motor vehicle safety is available through the website.

Telephone: Vehicle Safety Hotline (toll-free) at 1-888-327-4236 (TTY: 1-800-424-9153).

Website: www.safercar.gov

Address: Administrator, NHTSA, 400 Seventh Street SW, Washington, DC 20590

REQUIRED DOCUMENTATION FOR IMPORTED MOTORCYCLES

If a Harley-Davidson motorcycle is imported into the United States, additional documentation is required for that motorcycle to be eligible for the United States Harley-Davidson Motorcycle Limited Warranty. An authorized Harley-Davidson dealer can provide a form explaining the requirements.

OWNER CONTACT INFORMATION

If you move from your present address, sell your motorcycle, or purchase a pre-owned Harley-Davidson motorcycle, see an authorized Harley-Davidson dealer to update your owner contact information.

This will provide Harley-Davidson with an accurate registration (as required by law in some countries), and will allow Harley-Davidson to notify you in the event of a recall or product program.

The rights and benefits conferred upon you and the obligations of Harley-Davidson as set forth herein are separate and distinct from any rights and duties set forth in any service contract you may have purchased from a dealership and/or third-party insurance company. Harley-Davidson does not authorize any entity to expand Harley-Davidson's warranty obligations in connection with your motorcycle or this limited warranty.

When updating your contact information, your authorized Harley-Davidson dealer will need your Vehicle Identification Number (VIN), odometer mileage, and date of vehicle transfer (if applicable).

QUESTIONS AND CONCERNS

If you have questions or concerns regarding the performance of your motorcycle or the application of the limited warranty described here, or are not satisfied with the service you are receiving from an authorized Harley-Davidson dealership, do the following:

1. Contact the selling and/or servicing dealership and speak to the sales and/or service manager.
2. If your concern cannot be addressed to your satisfaction by the dealership, contact the Harley-Davidson Customer Support Center by mailing your concern to the following address or calling the phone number below.

In the U.S., state warranty laws, often referred to as lemon laws, may provide you with certain rights not specifically mentioned here. To the extent allowed by your state, Harley-Davidson requests that you first send written notification of any defect or warranty non-conformity that you have experienced with your motorcycle to Harley-Davidson. Harley-Davidson appreciates the opportunity to investigate your concerns and restore your satisfaction in your motorcycle by making the necessary repairs consistent with the terms of

Harley-Davidson's limited warranty. Harley-Davidson requests that you send your complaint to the Harley-Davidson Customer Support Center.

- Harley-Davidson Motor Company Attention:
Harley-Davidson Customer Support Center P.O. Box 653
Milwaukee, Wisconsin 53201 1-800-258-2464 (U.S. only)
1-414-343-4056

This warranty does not mean that each Harley-Davidson motorcycle is free from defects. Defects may be unintentionally introduced into motorcycles during the design and manufacturing processes and such defects could result in the

need for repairs. For this reason, Harley-Davidson provides the Limited Warranty in order to remedy any such defects that result in a component malfunction or failure during the warranty period. The remedy under this written warranty, and any implied warranty, is limited to repair, replacement or adjustment of the defective part. This exclusive remedy shall not be deemed to have failed its essential purpose so long as Harley-Davidson, through its authorized dealers, is willing and able to repair, replace or adjust defective parts in the prescribed manner. Harley-Davidson's liability, if any, shall in no event exceed the cost of correcting any defect as herein provided and upon expiration of this warranty, any such liability shall terminate.



NOTES



2021 HARLEY-DAVIDSON LIMITED MOTORCYCLE WARRANTY

24 Months/Unlimited Miles

Harley-Davidson warrants for any new 2021 Harley-Davidson® motorcycle that an authorized Harley-Davidson dealer will repair or replace without charge any parts found on your motorcycle that malfunction or fail during normal use during the applicable coverage period due to an issue with factory supplied materials or factory workmanship. Such repair or replacement of failed parts will be Harley-Davidson's sole obligation and your sole and exclusive remedy under this limited warranty. This limited warranty applies only for the duration identified below.

No person, including Harley-Davidson dealers, may modify, extend or waive any part of this warranty. As a condition of this warranty, you are responsible for properly using, maintaining, and caring for your motorcycle as outlined in your Owner's Manual. Harley-Davidson recommends that you maintain copies of all maintenance records and receipts.

THERE IS NO OTHER EXPRESS WARRANTY (OTHER THAN THE SEPARATE EMISSIONS, NOISE AND RADIO LIMITED WARRANTIES) ON THE MOTORCYCLE. Any implied warranty of merchantability or fitness for particular purpose is limited to the duration of the express warranty, or to the duration set forth in your state's warranty statutes,

whichever is shorter. Any implied warranty is not transferred to subsequent purchasers/buyers of the motorcycle.

The implied warranty of fitness for a particular purpose does not apply if your motorcycle is used for racing, even if the motorcycle is equipped for racing. Some states do not allow limitations on how long an implied warranty lasts, so the above limitation may not apply to you.

TO THE FULLEST EXTENT ALLOWED BY A LAW, NEITHER HARLEY-DAVIDSON, NOR ITS AUTHORIZED DEALERS SHALL BE LIABLE FOR LOSS OF TIME, INCONVENIENCE, LOSS OF MOTORCYCLE USE, COMMERCIAL LOSS OR ANY OTHER INCIDENTAL OR CONSEQUENTIAL DAMAGES.

Harley-Davidson and your dealer are not responsible for any time or income that you lose, any inconvenience, the loss of your transportation or use of your motorcycle, the cost of a rental motorcycle, fuel, travel, meals, or lodging, or for any other incidental or consequential damages you may have.

Punitive, exemplary, or multiple damages may not be recovered unless applicable law prohibits their disclaimer. You may not bring any warranty-related claim as a class representative, a private attorney general, a member of a class of claimants or in any other representative capacity.

Harley-Davidson shall not be liable for any damages caused by delay in delivery or furnishing of any products and/or services.

Some states do not allow the exclusion or limitation of incidental or consequential damages, so the above limitation or exclusion may not apply to you.

This warranty gives you specific legal rights, and you may also have other rights which vary from state to state. Decisions based on state lemon laws, state arbitration awards and/or dispute resolution awards supersede Company policy.

The following terms and conditions apply to this limited warranty:

Duration

1. The duration of this limited warranty is 24-months, starting from the earlier of (a) the date of initial retail purchase and delivery of the motorcycle from an authorized Harley-Davidson dealer, or (b) the third anniversary of the last day of the model year of the motorcycle. Your authorized Harley-Davidson dealer will submit an electronic Sales and Warranty Registration form to initiate your limited warranty.
2. Any unexpired portion of this limited warranty will be transferred to subsequent owners, upon the resale of the motorcycle during the limited warranty period.

Owner's Obligations

To obtain warranty service, return your motorcycle at your expense within the limited warranty period, to an authorized Harley-Davidson dealer. The authorized Harley-Davidson dealer should be able to provide warranty service during normal business hours, depending upon the workload of the authorized dealer's service department and the availability of necessary parts. The dealer may request that you make an appointment and deliver the motorcycle for diagnosis and repair at the scheduled time.

Exclusions

This limited warranty will not apply to any On-Road motorcycle.

1. Which has not been operated or maintained as specified in the owner's manual.
2. Which has been abused, neglected, misused, improperly stored, used "off the highway," or used for racing or competition of any kind.
3. Which is not equipped to comply with the laws of the market in which it is registered.

4. Which has off-road parts or competition parts installed to enhance performance, a trailer hitch, or has other unapproved modifications (even if these modifications include genuine Harley-Davidson® parts and accessories that are not approved for use on your motorcycle). These modifications may void all or parts of your new motorcycle limited warranty. See an authorized Harley-Davidson dealer for details.
 5. Which has been subjected to an act of God, war, riot, insurrection, nuclear contamination, natural disasters, including, but not limited to, lightning, forest fires, dust storms, hail storms, ice storms, earthquakes, or floods, or other circumstances out of Harley-Davidson's control.
 6. Which has been in an accident or collision, dropped or struck.
2. Which has been abused, neglected, misused, improperly stored, or used for racing or competition of any kind.
 3. Which is not equipped to comply with the laws of the market in which it is registered.
 4. Which has aftermarket off-road parts, competition parts installed to enhance performance, a trailer hitch, or has other unapproved modifications (even if these modifications include genuine Harley-Davidson® parts and accessories that are not approved for use on your motorcycle). These modifications may void all or parts of your new motorcycle limited warranty. See an authorized Harley-Davidson dealer for details.
 5. Which has been subjected to an act of God, war, riot, insurrection, nuclear contamination, natural disasters, including, but not limited to, lightning, forest fires, dust storms, hail storms, ice storms, earthquakes, or floods, or other circumstances out of Harley-Davidson's control.
 6. Which has been in an accident, collision, dropped or struck.

On-Road/Off-Road Vehicles

Harley-Davidson's Pan America was designed for on-road and moderate off-road use. This entails use on paved and gravel roads and groomed trails, but does not include competition courses, rally routes or similar uses.

This limited warranty will not apply to any On-Road/ Off-Road motorcycle

1. Which has not been operated or maintained as specified in the Owner's Manual.

Other Limitations

This limited warranty does not cover:

1. Parts and labor for normal maintenance as recommended in the Owner's Manual, or the replacement of parts due to normal wear and tear including, but not limited to, the following: light bulbs, tires, lubrication, oil and filter change, fuel system cleaning, battery maintenance, engine tune-up, spark plugs, brake, clutch, chain/belt adjustments and chain replacement.
2. Cosmetic concerns that arise as a result of owner abuse, lack of proper maintenance or environmental conditions (except concerns that result from defects in factory materials or workmanship, which are covered by this limited warranty for the duration of the limited warranty period).
3. Any cosmetic condition existing at the time of retail delivery that has not been documented by the authorized Harley-Davidson selling dealer prior to retail delivery.
4. Defects or damage to the motorcycle caused by alterations outside of Harley-Davidson factory specifications or caused by alterations or use of parts or accessories not approved for the make and model year of your motorcycle.
5. Damage caused by installation or use of non-Harley-Davidson components, even those installed by an authorized Harley-Davidson dealership, that cause a genuine Harley-Davidson[®] part to fail. Examples include but are not limited to performance-enhancing powertrain components or software, exhaust systems, trailer hitches, non-approved tires, lowering kits, handlebars, add-ons connected to the factory electrical system, and auxiliary storage or luggage.
6. Upgraded parts are not allowed as a warranty replacement. The limited warranty allows for repair or replacement of failed parts to put the vehicle, component or part back to its original condition with factory supplied materials and as delivered. We will take all steps to repair/replace the part to make it correct for the customer. This does not include upgrades to parts - unless no other suitable component is available as a direct replacement. This would require an authorization prior to repair.
7. **United States customers:** Defects or damage impacting the functionality of powertrain components in a motorcycle that has been tuned using a tuner or calibration that was not covered by a California ARB Executive Order or otherwise approved by EPA.

Important: Read Carefully

1. Authorized Harley-Davidson dealers are independently owned and operated and may sell non-Harley-Davidson products. Because of this, HARLEY-DAVIDSON IS NOT RESPONSIBLE FOR THE SAFETY, QUALITY, OR SUITABILITY OF ANY NON-HARLEY-DAVIDSON PART, ACCESSORY OR DESIGN MODIFICATION INCLUDING, BUT NOT LIMITED TO, LABOR WHICH MAY BE SOLD AND/OR INSTALLED BY AUTHORIZED HARLEY-DAVIDSON DEALERS.
2. This limited warranty is a contract between you and Harley-Davidson. It is separate and apart from any warranty or service plan you may receive or purchase from an authorized Harley-Davidson dealer. An authorized Harley-Davidson dealer is not authorized to alter, modify, expand, or in any way change the terms and conditions of this limited warranty.
3. Any warranty work or parts replacement authorized by Harley-Davidson will not preclude Harley-Davidson from later relying on any exclusion where applicable.
4. Harley-Davidson and its authorized dealers reserve the right to modify or service motorcycles designed and manufactured by Harley-Davidson at any time without incurring any additional obligation to make the same alteration or change to a motorcycle previously built and sold. Harley-Davidson reserves the right to provide post-warranty repairs, conduct repair campaigns, offer good-will or customer satisfaction repairs or extend the warranty coverage for certain motorcycles at its sole discretion. Said repairs or extensions of warranty coverage in no way obligate Harley-Davidson to provide similar accommodations to other owners of similar motorcycles. Sometimes Harley-Davidson may offer a special adjustment program to pay all or part of the cost of certain repairs beyond the terms of your limited warranty. Check with your authorized Harley-Davidson dealer to learn whether such programs are available. Your state may prohibit these types of offers, in which case, they may not be available.
5. The fact that a part is labeled, or branded Harley-Davidson does not necessarily make it appropriate or warranted for the make and model of the motorcycle. The use of parts not designed and tested for the motorcycle may have negative consequences on the performance of the motorcycle and may create conditions not covered by the limited warranty.

Environmental Factors

1. Warranty will cover rust/corrosion and/or pitting on one component, one time only, under appropriate conditions. If a vehicle is exhibiting any of these conditions on more than one component, warranty coverage will be denied.
2. Warranty will cover rust/corrosion and/or pitting on multiple components only if they are the same component (i.e. both mirrors, both rider footboards, etc.)
3. Warranty will not cover rust/corrosion and/or pitting on wheels at any time unless the condition had been properly documented in the DPQA. For warrantable conditions see Cosmetic Quality Guide.

4. Warranty will not cover rust/corrosion and/or pitting as a result of damage from road debris, hazards, neglect, chemical exposure or abuse/misuse of the motorcycle.
5. Warranty will not cover rust/corrosion inside fuel tanks.
6. Warranty will not cover rust/corrosion and/or pitting or part wear that results from off-road use.

The owner is responsible for protecting the motorcycle from any cosmetic concerns that result from use and/or from exposure to the elements.



2021 AUSTRALIA/NEW ZEALAND HARLEY-DAVIDSON MOTORCYCLE LIMITED WARRANTY

24 Months/Unlimited Miles

This motorcycle limited warranty, referred to below as the "H-D Motorcycle Warranty" applies to all persons who purchase a new 2021 or prior-model Harley-Davidson motorcycle in Australia and New Zealand only after 1st January 2020.

Your Consumer Rights

The benefits given to you under this H-D Motorcycle Warranty are additional to, and do not detract from, other rights and remedies that you may have in respect of the motorcycle under Australian and New Zealand laws, including consumer protection laws.

In Australia, our goods come with guarantees that cannot be excluded under the Australian Consumer Law. You are entitled to a replacement or refund for a major failure and compensation for any other reasonably foreseeable loss or damage. You are also entitled to have the goods repaired or replaced if the goods fail to be of acceptable quality and the failure does not amount to a major failure.

In New Zealand, our goods also come with guarantees that cannot be excluded under the New Zealand Consumer Guarantees Act.

Warranty

This H-D Motorcycle Warranty, is provided by **Harley-Davidson, Motor Company**, P.O. Box 653, Milwaukee, Wisconsin 53201, U.S.A, phone: +1 (414) 343-4056, ("Harley-Davidson").

Harley-Davidson warrants for any new 2021 Harley-Davidson motorcycle that an authorised Harley-Davidson dealer will repair or replace without charge any parts found to be defective in factory materials or workmanship under normal use during the warranty period set out below.

Such repair or replacement of parts will be Harley-Davidson's sole obligation and your sole remedy under this H-D Motorcycle Warranty, however you may have other rights under Australian and New Zealand laws, as described above.

Note: Goods presented for repair may be replaced by refurbished goods of the same type rather than being repaired. Refurbished parts may be used to repair goods.

The following terms and conditions apply to this H-D Motorcycle Warranty:

Warranty Period

The duration of this H-D Motorcycle Warranty is twenty-four months, starting from the earlier of:

- (a) the date of delivery by an authorised Harley-Davidson dealer to the first retail purchaser; or
- (b) the third anniversary of the last day of the model year of the motorcycle (if not sold to a retail purchaser before that date).

Your authorised Harley-Davidson dealer will submit an electronic Sales and Warranty Registration form to initiate your H-D Motorcycle Warranty.

Note: If the motorcycle was used as a demonstrator or company motorcycle, then the warranty period may have started and/or expired prior to the initial retail sale. See an authorised Harley-Davidson dealer for details.

Any unexpired portion of this H-D Motorcycle Warranty will be transferred to subsequent owners, upon the resale of the motorcycle during the warranty period. See the OWNER CONTACT INFORMATION section of the Owner's Manual for information regarding notification of ownership changes.

Obtaining Warranty Service

To obtain warranty service, return your motorcycle at your expense within the warranty period to an authorised dealer.

Harley-Davidson's network of authorised dealers is large, and continues to expand. To find current contact information for your nearest authorised dealer, visit our website at www.h-d.com.au.

The authorised Harley-Davidson dealer should be able to provide warranty service during normal business hours and as soon as possible, depending upon the workload of the authorised dealer's service department and the availability of necessary parts

You are responsible for collecting the motorcycle from the authorized dealer once the warranty service has been completed, at your expense.

Exclusions

This H-D Motorcycle Warranty will not apply to any On-Road motorcycle (or part or accessory):

1. Which has not been operated or maintained as specified in the Owner's Manual.
2. Which has been abused, neglected, misused, improperly stored, used "off the highway," or used for racing or competition of any kind.
3. Which was not originally manufactured for use or sold in Australia and New Zealand and/or does not comply with Australian and New Zealand homologation requirements.

4. Which has off-road parts or competition parts installed to enhance performance, or has unapproved modifications. These modifications may void all or part of your new H-D Motorcycle Warranty. See an authorised Harley-Davidson dealer for details.
5. Where damage is caused by, or Harley-Davidson is unable to honour this H-D Motorcycle Warranty due to, acts of God, war, riot, insurrection, natural disasters, including, but not limited to, nuclear contamination, lightning, forest fires, dust storms, hail storms, ice storms, earthquakes, floods, or other circumstances out of Harley-Davidson's control.
6. Which has been in an accident, collision, dropped or struck.

Note: Even though this H-D Motorcycle Warranty does not apply in the circumstances set out above, you may still have rights under Australian and New Zealand laws, including the Australian Consumer Law in such circumstances.

On-Road/Off-Road Vehicles

Harley-Davidson's Pan America was designed for on-road and moderate off-road use. This entails use on paved and gravel roads and groomed trails, but does not include competition courses, rally routes or similar uses.

This limited warranty will not apply to any On-Road/Off-Road motorcycle:

1. Which has not been operated or maintained as specified in the Owner's Manual.
2. Which has been abused, neglected, misused, improperly stored, used "off the highway," or used for racing or competition of any kind.
3. Which is not equipped to comply with the laws of the market in which it is registered.
4. Which has aftermarket off-road parts, competition parts installed to enhance performance, a trailer hitch, or has other unapproved modifications (even if these modifications include genuine Harley-Davidson® parts and accessories that are not approved for use on your motorcycle). These modifications may void all or parts of your new motorcycle limited warranty. See an authorized Harley-Davidson dealer for details.
5. Which has been subjected to an act of God, war, riot, insurrection, nuclear contamination, natural disasters, including, but not limited to, lightning, forest fires, dust storms, hail storms, ice storms, earthquakes, or floods, or other circumstances out of Harley-Davidson's control.
6. Which has been in an accident, collision, dropped or struck.

Other Limitations

This H-D Motorcycle Warranty does not cover:

1. Parts and accessories not manufactured by Harley-Davidson, or any damage caused to the motorcycle by the installation of such parts and accessories, even if such parts and accessories are installed on the motorcycle at the date of initial retail purchase. A separate third party warranty may apply to such parts and accessories. See an authorised Harley-Davidson dealer for details.
2. Parts and labour for normal maintenance as recommended in the Owner's Manual, or the replacement of parts due to normal wear and tear including, but not limited to, the following: light bulbs, tyres, lubrication, oil and filter change, fuel system cleaning, battery maintenance, engine tune-up, spark plugs, brake, clutch, chain/belt adjustment and chain replacement.
3. Cosmetic or other concerns that arise as a result of owner abuse, lack of proper maintenance or environmental conditions (except concerns that result from defects in factory materials or workmanship, which are covered by this H-D Motorcycle Warranty for the duration of the warranty period).
4. Any cosmetic condition existing at the time of retail delivery that has not been documented by the authorised Harley-Davidson selling dealer prior to retail delivery.
5. Defects or damage to the motorcycle caused by alterations outside of Harley-Davidson's factory specifications, including the installation of competition or closed course parts and accessories and the addition of loads and stresses to the motorcycle above those recommended by Harley-Davidson.
6. Damage caused by installation or use of non-Harley-Davidson components, even those installed by an authorised dealership, that cause a Harley-Davidson part to fail. Examples include, but are not limited to performance-enhancing powertrain components or software, exhaust systems, non-approved tyres, lowering kits, handlebars, add-ons connected to the factory electrical system, auxiliary storage or luggage, tow bars, etc.

Note: Even though this H-D Motorcycle Warranty does not cover the circumstances set out above, you may still have rights under Australian and New Zealand laws, including the Australian Consumer Law.

Important: Read Carefully

1. Authorised Harley-Davidson dealers are independently owned and operated and may sell non-Harley-Davidson products. Because of this, HARLEY-DAVIDSON IS NOT RESPONSIBLE FOR THE SAFETY, QUALITY, OR SUITABILITY OF ANY NON-HARLEY-DAVIDSON PART, ACCESSORY OR DESIGN MODIFICATION WHICH MAY BE SOLD AND/OR INSTALLED BY AUTHORISED HARLEY-DAVIDSON DEALERS OR LABOUR CARRIED OUT BY DEALERS.
2. This H-D Motorcycle Warranty is a contract between you and Harley-Davidson. It is separate and apart from any warranty you may receive or purchase from an authorised Harley-Davidson dealer. An authorised Harley-Davidson dealer is not authorised to alter, modify, or in any way change the terms and conditions of this H-D Motorcycle Warranty.

Any warranty work or parts replacement authorised by Harley-Davidson will not preclude Harley-Davidson from later relying on any exclusion where Harley-Davidson later becomes aware that an exclusion applied or the warranty claim did not otherwise comply with the terms of this H-D Motorcycle Warranty.

Environmental Factors

1. Warranty will cover rust/corrosion and/or pitting on one component, one time only, under appropriate conditions. If a vehicle is exhibiting any of these conditions on more than one component, warranty coverage will be denied.
2. Warranty will cover rust/corrosion and/or pitting on multiple components only if they are the same component (i.e. both mirrors, both rider footboards, etc.)
3. Warranty will not cover rust/corrosion and/or pitting on wheels at any time unless the condition had been properly documented in the DPQA. For warrantable conditions see Cosmetic Quality Guide.
4. Warranty will not cover rust/corrosion and/or pitting as a result of damage from road debris, hazards, neglect, chemical exposure or abuse/misuse of the motorcycle.
5. Warranty will not cover rust/corrosion inside fuel tanks.
6. Warranty will not cover rust/corrosion and/or pitting or part wear that results from off-road use.

The owner is responsible for protecting the motorcycle from any cosmetic concerns that result from use and/or from exposure to the elements.

NOTES



2021 HARLEY-DAVIDSON MOTORCYCLE NOISE CONTROL SYSTEM LIMITED WARRANTY

The following limited warranty applies to the noise control system, is in addition to the MOTORCYCLE LIMITED WARRANTY and EMISSION CONTROL SYSTEM LIMITED WARRANTY, and applies only to Harley-Davidson motorcycles sold in the U.S.

Harley-Davidson warrants to the first owner and each subsequent owner that this motorcycle is designed and built so as to conform at the time of sale with applicable regulations of the U.S. Environmental Protection Agency (as tested following F-76 Drive-By test procedure) and that it is free from defects in factory materials and workmanship which can cause this motorcycle not to meet U.S. Environmental Protection Agency Standards within one (1) year from initial retail purchase and delivery from an authorized Harley-Davidson dealer or one (1) year from the [second] anniversary of the last day of the model year of the motorcycle, or 6,000 km (3730 mi) whichever occurs first. Any unexpired portion of this limited warranty will be transferred to subsequent owners, upon the resale of the motorcycle during the limited warranty period. If the motorcycle was used as a demonstrator or company motorcycle, then the limited warranty period may have started and/or expired prior to the initial retail sale. See an authorized Harley-Davidson dealer for details.

THERE IS NO OTHER EXPRESS WARRANTY (OTHER THAN THE SEPARATE MOTORCYCLE AND EMISSIONS LIMITED WARRANTIES) ON THE MOTORCYCLE. ANY IMPLIED WARRANTY OF MERCHANTABILITY OR FITNESS FOR PARTICULAR PURPOSE IS LIMITED TO THE DURATION OF THIS LIMITED WARRANTY.

Some states do not allow limitations on how long an implied warranty lasts, so the above limitation may not apply to you.

The limited warranty period shall begin on the date the motorcycle is delivered to the first retail purchaser or, if the motorcycle is placed in service as a demonstrator or company motorcycle prior to sale at retail, on the date it is first placed in service.

THE FOLLOWING ITEMS ARE NOT COVERED BY THE NOISE CONTROL SYSTEM LIMITED WARRANTY

1. Failures which arise as a result of misuse, alteration, or non-performance of maintenance as specified in the Owner's Manual.
2. Replacing, removing, or modifying any portion of the NOISE CONTROL SYSTEM (consisting of the exhaust system and air intake/cleaner assembly) with parts not certified to be noise legal for street use.
3. Any motorcycle on which the odometer mileage has been changed so that the mileage cannot be determined.

4. TO THE FULLEST EXTENT ALLOWED BY LAW, NEITHER HARLEY-DAVIDSON NOR ITS AUTHORIZED DEALERS SHALL BE LIABLE FOR LOSS OF TIME, INCONVENIENCE, LOSS OF MOTORCYCLE USE, COMMERCIAL LOSS OR OTHER INCIDENTAL OR CONSEQUENTIAL DAMAGES.

Some states do not allow the exclusion or limitation of incidental or consequential damages, so the above limitation or exclusion may not apply to you.

Other Rights

This limited warranty gives you specific legal rights, and you may have other rights which vary from state to state.

Recommendations for Required Maintenance

It is recommended that any noise system maintenance be performed by an authorized Harley-Davidson dealer using genuine Harley-Davidson replacement parts. The maintenance, replacement or repair of the noise control system may be performed by any other qualified service outlet or individual. Non-genuine Harley-Davidson parts may be used only if such parts are certified to comply with U.S. Environmental Protection Agency Standards.

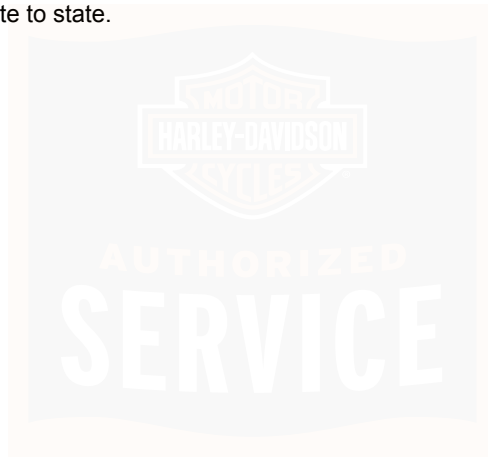

2021 HARLEY-DAVIDSON EMISSION CONTROL SYSTEM LIMITED WARRANTY

USA Owners 49 State Limited Emissions Warranty

The following limited warranty applies to the emission control system, is in addition to the MOTORCYCLE LIMITED WARRANTY and NOISE CONTROL SYSTEM LIMITED WARRANTY, and applies only to Harley-Davidson motorcycles certified for sale, registered, and normally operated in the U.S. For California models, refer to the CALIFORNIA EMISSIONS CONTROL WARRANTY STATEMENT for additional warranty provisions.

Harley-Davidson Motor Company warrants to the first owner and each subsequent owner that this vehicle is designed, built, and equipped so as to conform at the time of sale with applicable regulations under section 7521 of Title 42 of the United States Code, and that it is free from defects in materials and workmanship which would cause this motorcycle to fail to conform with applicable emissions regulations for five (5) years from the initial retail purchase and delivery from an authorized Harley-Davidson dealer (or five (5) years from the date the motorcycle is first placed in service, if it is first placed in service as a "demonstrator" or "company" motorcycle prior to delivery), or 30,000 km (18641 mi), whichever occurs first. Any unexpired portion of this limited warranty will be

transferred to subsequent owners, upon the resale of the motorcycle during the warranty period.

THERE IS NO OTHER EXPRESS WARRANTY (OTHER THAN THE SEPARATE MOTORCYCLE AND NOISE LIMITED WARRANTIES) ON THE MOTORCYCLE. ANY IMPLIED WARRANTY OF MERCHANTABILITY OR FITNESS FOR PARTICULAR PURPOSE IS LIMITED TO THE DURATION OF THIS WARRANTY.

Some states do not allow limitations on how long an implied warranty lasts, so the above limitation may not apply to you.

The limited warranty period shall begin on the date the motorcycle is delivered to the first retail purchaser or, if the motorcycle is placed in service as a demonstrator or company motorcycle prior to sale at retail, on the date it is first placed in service.

THE FOLLOWING ITEMS ARE NOT COVERED BY THE EMISSION CONTROL SYSTEM LIMITED WARRANTY

1. Failures which arise as a result of misuse, tampering, alterations, accident, acts of nature, or improper or inadequate maintenance as specified in the Owner's Manual.
2. Required maintenance services (as specified in the Owner's Manual) and the replacement of parts (such as spark plugs, fuel and oil filters, etc.) used in required maintenance.

3. Any motorcycle on which the odometer mileage has been changed so that the mileage cannot be determined.
4. TO THE FULLEST EXTENT ALLOWED BY LAW, NEITHER HARLEY-DAVIDSON NOR ITS AUTHORIZED DEALERS SHALL BE LIABLE FOR LOSS OF TIME, INCONVENIENCE, TOWING OF THE VEHICLE, LOSS OF MOTORCYCLE USE, COMMERCIAL LOSS OR OTHER INCIDENTAL OR CONSEQUENTIAL DAMAGES.

Some states do not allow the exclusion or limitation of incidental or consequential damages, so the above limitation or exclusion may not apply to you.

Items Covered by this Emission Warranty

The emission control system warranty may cover the following parts if the defect is deemed to be emissions-related:

- Air cleaner assembly
- Cam shaft
- Spark plug
- Ignition coil
- Ignition wires
- Vapor valve
- Catalytic converter

- Muffler
- Crankcase breather
- MAP sensor
- TMAP sensor
- Intake air temperature sensor
- Throttle position sensor
- Fuel injectors
- Induction module or throttle body
- Engine temperature sensor
- Electronic control unit
- Oxygen sensors
- Fuel pump module
- Engine Control Module

Fuel Tank (non-cosmetic failures only)

- Leaks
- Fuel vapor separator
- Fuel cap

If used on the above: hoses, clamps, fittings, tubing, sealing gaskets and mounting hardware.

Detailed instructions for proper maintenance and use of this motorcycle, including the time and/or mileage intervals at which such maintenance is to be performed, may be found in this Owner's Manual under SERVICE INTERVALS AND RECORDS > SERVICE RECORDS (Page 211).

Other Rights

This limited warranty gives you specific legal rights, and you may have other rights which vary from state to state.

Recommendations for Required Maintenance

It is recommended that any emission system maintenance be performed by an authorized Harley-Davidson dealer using genuine Harley-Davidson replacement parts. However the maintenance, replacement or repair of the emissions control system may be performed by any other qualified service outlet or individual. Non-genuine Harley-Davidson parts may be used only if such parts are certified to comply with U.S. Environmental Protection Agency Standards.



NOTES



CALIFORNIA EMISSIONS CONTROL WARRANTY STATEMENT

USA Owners California Limited Emissions Warranty

Your Warranty Rights and Obligations

The California Air Resources Board and Harley-Davidson Motor Company are pleased to explain the emission control system warranty on your new motorcycle. In California, new motor vehicles must be designed, built and equipped to meet the State's stringent anti-smog standards. Harley-Davidson Motor Company warrants the emission control system on your motorcycle for the periods of time listed below, provided there has been no abuse, unapproved modification, neglect or improper maintenance of your motorcycle.

Your emission control system may include parts such as the carburetor or fuel-injection system, the ignition system, catalytic converter, and engine computer. Also included may be hoses, belts, connectors and other emission-related assemblies.

Where a warrantable condition exists, within the warranty period noted below, Harley-Davidson will repair your motorcycle at no cost to you including diagnosis, parts and labor.

Manufacturer's Warranty Coverage

For a period of use of five years or 30,000 km (18641 mi), whichever first occurs, beginning on the date the motorcycle is delivered to the ultimate purchaser or, if the motorcycle is placed in service as a demonstrator or company motorcycle prior to sale at retail, the date it is first placed in service.

If any emission-related part on your motorcycle is defective, the part will be repaired or replaced by Harley-Davidson Motor Company. This is your emission control system DEFECTS WARRANTY.

Owner's Warranty Responsibilities

As the motorcycle owner, you are responsible for the performance of the required maintenance listed in your Owner's Manual. Harley-Davidson recommends that you retain all receipts covering maintenance on your motorcycle, but Harley-Davidson cannot deny emissions warranty coverage solely for the lack of receipts or for your failure to ensure the performance of all scheduled maintenance, unless the condition is caused by your lack of maintenance or improper maintenance.

You are responsible for presenting your motorcycle to an authorized Harley-Davidson dealer as soon as a problem exists. The warranty repairs should be completed in a reasonable amount of time, not to exceed 30 days.

As the motorcycle owner, you should also be aware that Harley-Davidson may deny you warranty coverage if your motorcycle or a part has failed due to abuse, neglect, improper maintenance or unapproved modifications.

If you have any questions regarding your warranty rights and responsibilities, you should contact Harley-Davidson Customer Service Department at 1-800-258-2464 (U.S. only) or 1-414-343-4056, or the California Air Resources Board at 9528 Telstar Ave., El Monte, California 91731.

Additional Warranty Terms

The emission control system of each new Harley-Davidson motorcycle was designed, built and tested using only Genuine Harley-Davidson parts and with these parts the motorcycle is certified as being in conformity with California emission control regulations.

We recommend that you take your motorcycle to an authorized Harley-Davidson dealer for repairs under this warranty. The dealer has factory-trained mechanics and genuine Harley-Davidson parts. However, in the case of an "emergency" (as defined below), you may have repairs performed at any available service establishment or by the owner, using any replacement part. An authorized Harley-Davidson dealer not being reasonably available, or a part not being available within a reasonable time period (not to exceed 30 days from the time the motorcycle is initially presented to a Harley-Davidson dealer for repair) constitutes

an "emergency." Harley-Davidson will reimburse the owner for such repairs, including diagnosis, only if it is established that the repairs are covered under this emission warranty. Harley-Davidson's parts reimbursement, however, will not exceed our suggested retail price for all warranted parts replaced and our labor reimbursement will be limited to our recommended time allowances for emission system repairs at the geographically appropriate hourly labor rate.

To obtain reimbursement from Harley-Davidson for such emergency repairs, you must keep all failed parts and original receipts, so you can present them to an authorized Harley-Davidson dealer for inspection. Harley-Davidson recommends that you bring your motorcycle to an authorized dealer for inspection to ensure that the emergency repairs were done properly.

Remember: Use of non-Harley-Davidson replacement parts may impair the effectiveness of the emission control system or otherwise damage your motorcycle. If other than genuine Harley-Davidson parts are used for maintenance, replacement or repair of components affecting emission control, you should obtain written assurances that such non-Harley-Davidson parts are warranted by their manufacturer to be equal in quality to Genuine Harley-Davidson parts in both performance and durability. The use of non-Harley-Davidson replacement parts does not invalidate the existing warranty, if any, on other Harley-Davidson components unless the non-Harley-Davidson parts cause damage to warranted parts or result in the creation

of an emissions non-compliant motorcycle. However, HARLEY-DAVIDSON ASSUMES NO LIABILITY UNDER THIS WARRANTY WITH RESPECT TO ANY PARTS WHICH ARE NOT GENUINE HARLEY-DAVIDSON PARTS, unless Harley-Davidson parts cause damage to non-genuine Harley-Davidson parts.

What Is Covered by this Emission Warranty

The emission control system warranty covers the following "warranted parts" only:

- Air cleaner assembly
- Cam shaft
- Spark plug
- Ignition coil
- Ignition wires
- Vapor valve
- Catalytic converter
- Muffler
- Crankcase breather
- MAP sensor
- TMAP sensor
- Intake air temperature sensor

- Throttle position sensor
- Fuel injectors
- Induction module or throttle body
- Engine temperature sensor
- Electronic control unit
- Oxygen sensors
- Carbon canister
- Purge control valve
- Fuel pump module
- Engine Control Module

Fuel Tank (non-cosmetic failures only)

- Leaks
- Fuel vapor separator
- Fuel cap

If used on the above: hoses, clamps, fittings, tubing, sealing gaskets and mounting hardware.

What Is Not Covered by this Emission Warranty

The emission control system warranty does not cover:

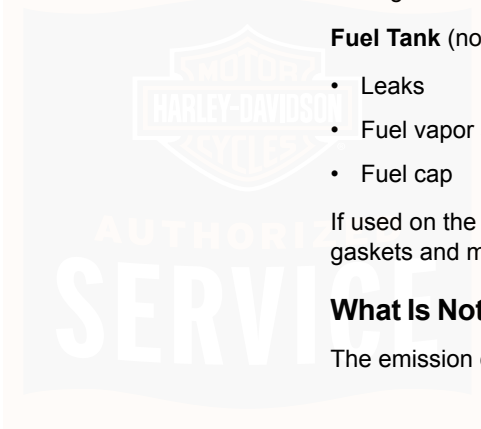

Malfunctions in any "warranted parts" caused by any of the following: abuse, misuse, unapproved modification or alteration, tampering, disconnection, or improper or inadequate maintenance. The warranty also does not cover replacement of listed parts in the event that the vehicle has been rendered emissions non-compliant in the state of California through actions noted above .

Damage resulting from accident, acts of nature or other events beyond the control of Harley-Davidson.

The repair or replacement of "warranted parts" which are scheduled for replacement prior to 30,000 km (18641 mi), once these parts have been replaced at the first replacement interval as part of required maintenance services.

TO THE FULLEST EXTENT ALLOWED BY LAW, NEITHER HARLEY-DAVIDSON NOR ITS AUTHORIZED DEALERS SHALL BE LIABLE FOR LOSS OF TIME, INCONVENIENCE, TOWING OF THE VEHICLE, LOSS OF MOTORCYCLE USE, COMMERCIAL LOSS OR OTHER INCIDENTAL OR CONSEQUENTIAL DAMAGES

Repairs and services performed by anyone other than an authorized Harley-Davidson Dealer (except in case of emergency as defined above).

Loss of time, inconvenience, loss of use of the motorcycle, towing of the vehicle, or commercial loss and/or consequential damages.

Repairs on any motorcycle of which odometer mileage has been changed so that mileage cannot be readily determined.

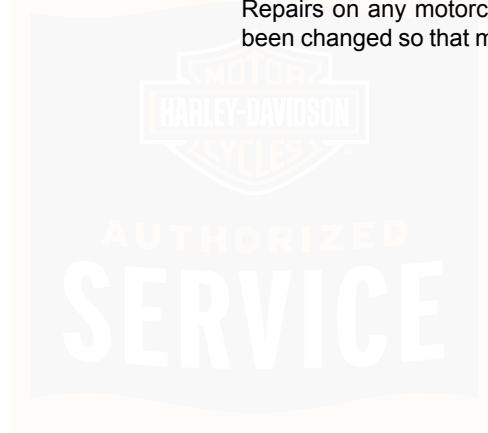

SERVICE RECORDS

Regular Service Intervals

Service must be performed at specified intervals to keep your Harley-Davidson motorcycle operating at peak performance. Refer to Service Intervals for table.

Refer to Service Actions for service action definitions used in the service interval table.

NOTE

- *The use of parts and service procedures other than Harley-Davidson approved parts and service procedures may void the limited warranty. Any alterations to the emission system components, such as the intake and exhaust system, may be in violation of motor vehicle laws.*

- *Some countries, such as Brazil, may require all regular maintenance or additional annual (or semi-annual) regular maintenance steps to be performed to keep your limited warranty in effect and/or comply with vehicle regulations. Check with your authorized Harley-Davidson dealer as well as the motorcycle regulations in your country.*
- *Whenever a vehicle is in for maintenance:*
 - always check for and complete recalls and open product programs.*
 - always verify that the latest calibration is installed.*
- *After completing the final service interval, repeat the service schedule starting at the 8000 km (5000 mi) interval.*

Service Intervals

Table 45. Regular Service Intervals: Harley-Davidson Pan America Models

COMPONENT	ACTION	1600 KM	8000 KM	16000 KM	24000 KM	32000 KM	40000 KM	48000 KM	56000 KM	64000 KM	72000 KM	80000 KM	NOTES
		1000 MI	5000 MI	10000 MI	15000 MI	20000 MI	25000 MI	30000 MI	35000 MI	40000 MI	45000 MI	50000 MI	
Service Intervals													
Electrical equipment and switches	Inspect	x	x	x	x	x	x	x	x	x	x	x	
Front tire pressure and tread	Check	x	x	x	x	x	x	x	x	x	x	x	1

Table 45. Regular Service Intervals: Harley-Davidson Pan America Models

COMPONENT	ACTION	1600 KM	8000 KM	16000 KM	24000 KM	32000 KM	40000 KM	48000 KM	56000 KM	64000 KM	72000 KM	80000 KM	NOTES
		1000 MI	5000 MI	10000 MI	15000 MI	20000 MI	25000 MI	30000 MI	35000 MI	40000 MI	45000 MI	50000 MI	
Front wheel spoke tightness (if equipped)	Check	x	x			x			x			x	2, 4, 3
Front brake fluid level	Inspect	x	x	x	x	x	x	x	x	x	x	x	6
DOT4 front brake fluid moisture content	Check	x	x	x	x	x	x	x	x	x	x	x	1, 2
Steering head bearings	Adjust	x		x		x		x		x		x	2
Steering head bearings	Lubricate						x					x	2
Clutch lever handlebar clamp screw torque	Tighten	x		x		x		x		x		x	1, 2, 5
Master cylinder handlebar clamp screw torque	Tighten	x		x		x		x		x		x	1, 2, 5
Air cleaner filter	Inspect	x	x	x	x	x	x	x	x	x	x	x	3
Engine oil and filter	Replace	x	x	x	x	x	x	x	x	x	x	x	1, 3
Coolant	Check	x	x	x	x	x	x	x	x	x	x	x	8
Coolant	Replace	Replace coolant every 30000 mi (48000 km)											2
Coolant hoses	Inspect	x	x	x	x	x	x	x	x	x	x	x	1, 2, 9
Radiators and oil cooler	Clean	x	x	x	x	x	x	x	x	x	x	x	
Brake system	Inspect	x	x	x	x	x	x	x	x	x	x	x	1, 2
Brake lines and fittings	Inspect	x	x	x	x	x	x	x	x	x	x	x	1, 2, 9
Fuel lines and fittings	Inspect	x	x	x	x	x	x	x	x	x	x	x	1, 2
Rear brake fluid level	Inspect	x	x	x	x	x	x	x	x	x	x	x	6
DOT4 rear brake fluid moisture content	Check	x	x	x	x	x	x	x	x	x	x	x	1, 2

Table 45. Regular Service Intervals: Harley-Davidson Pan America Models

COMPONENT	ACTION													NOTES	
		1600 KM 1000 MI	8000 KM 5000 MI	16000 KM 10000 MI	24000 KM 15000 MI	32000 KM 20000 MI	40000 KM 25000 MI	48000 KM 30000 MI	56000 KM 35000 MI	64000 KM 40000 MI	72000 KM 45000 MI	80000 KM 50000 MI			
Brake systems	Replace Flush brake systems and replace DOT 4 hydraulic brake fluid every two years or sooner if moisture content is 3 percent or greater.											2		
Brake pads and discs	Inspect	x	x	x	x	x	x	x	x	x	x	x			
Jiffy stand	Lubricate	x	x	x	x	x	x	x	x	x	x	x		2, 3	
Centerstand (if equipped)	Lubricate	x	x	x	x	x	x	x	x	x	x	x		2, 3	
Clutch system	Adjust	x	x	x	x	x	x	x	x	x	x	x		2, 3	
Brake and clutch controls	Lubricate	x	x	x	x	x	x	x	x	x	x	x		2, 7, 3	
Rear wheel spoke tightness (if equipped)	Check	x	x				x				x			x	2, 3, 4
Rear tire pressure and tread	Check	x	x	x	x	x	x	x	x	x	x	x		1	
Drive chain, sprockets and chain guide	Inspect	x	x	x	x	x	x	x	x	x	x	x		2, 3	
Drive chain	Adjust Clean, lubricate and adjust drive chain every 600 mi (1000 km)											2, 3		
Exhaust system, fasteners and shields	Inspect	x	x	x	x	x	x	x	x	x	x	x		1, 3	
12 volt battery	Check Check battery, terminal torque and clean connections annually. Lubricate terminals with ELECTRICAL CONTACT LUBRICANT.											1		
Spark plugs	Replace Replace spark plugs every two years or every 10,000 mi (16,000 km), whichever comes first.											2		
Front forks	Rebuild Disassemble, inspect, rebuild front forks and replace fork oil every 50000 mi (80000 km)											2		
Rear sprocket compensator	Inspect Inspect rear sprocket isolators for wear at each rear tire change.											2, 3		
Component and system functions	Road Test	x	x	x	x	x	x	x	x	x	x	x			

Table 45. Regular Service Intervals: Harley-Davidson Pan America Models

COMPONENT	ACTION	1600 KM	8000 KM	16000 KM	24000 KM	32000 KM	40000 KM	48000 KM	56000 KM	64000 KM	72000 KM	80000 KM	NOTES
		1000 MI	5000 MI	10000 MI	15000 MI	20000 MI	25000 MI	30000 MI	35000 MI	40000 MI	45000 MI	50000 MI	
NOTES													
<p>1. Perform annually or at specified intervals, whichever comes first.</p> <p>2. Should be performed by an authorized Harley-Davidson dealer, unless you have the proper tools, service data and are mechanically qualified.</p> <p>3. Perform maintenance more frequently in severe riding conditions. This includes extreme temperatures, dusty environments, mountainous or rough roads, long storage conditions, short runs, heavy stop/go traffic or poor fuel quality.</p> <p>4. Perform spoke tension check at 1,000 mi (2,000 km), 5,000 mi (8,000 km), 20,000 mi (32,000 km) services and every 15,000 mi (24,000 km) interval thereafter. Not all vehicles have spoked wheels. Consult appropriate topic in the service manual.</p> <p>5. For torque instructions, see Shop Practices in the service manual.</p> <p>6. Brake fluid level drops as brake pads wear.</p> <p>7. Use HARLEY LUBE.</p> <p>8. Check coolant level, freeze point and inspect for leaks.</p> <p>9. Check for leaks, contact or abrasion.</p>													

Service Actions

Table 46. Service Action Definitions

ACTION	DEFINITION
Inspect	Carefully examine component for excess wear, abnormality, contact, or leaks.
Check	Verify the component is within the owner's manual or service manual service limits. Adjust or repair as necessary.

Table 46. Service Action Definitions

ACTION	DEFINITION
Lubricate	Lubricate the component as specified in the owner's or service manual with Harley-Davidson approved product.
Replace	Replace the component at the specified intervals.

Table 46. Service Action Definitions

ACTION	DEFINITION
Clean	Clean the component as specified in the owner's or service manual.
Rebuild	Rebuild the component according to the procedures in the service manual.

Maintenance Records

Maintain a record of this service to keep your new motorcycle limited warranty in force. Refer to Table 47.

Table 47. Owner's Maintenance Records

SERVICE MILE INTERVAL	DATE	DEALER NUMBER	TECHNICIAN NAME	TECHNICIAN SIGNATURE
1,600 km (1,000 mi)				
8,000 km (5,000 mi)				
16,000 km (10,000 mi)				
24,000 km (15,000 mi)				
32,000 km (20,000 mi)				
40,000 km (25,000 mi)				
48,000 km (30,000 mi)				
56,000 km (35,000 mi)				
64,000 km (40,000 mi)				
72,000 km (45,000 mi)				
80,000 km (50,000 mi)				



A large, semi-transparent logo with the word "SERVICE" in a bold, sans-serif font. The logo is centered at the bottom of the page and has a light blue and orange color scheme.

NOTES



GENERAL

For additional certification information related to your motorcycle, look up your Vehicle Identification Number (VIN) on <https://serviceinfo.harley-davidson.com>.

ACRONYMS AND ABBREVIATIONS

Table 48. Acronyms and Measurement Symbols

ITEM	DEFINITION
A	Amperes
ABS	Anti-lock braking system
AC	Alternating current
ACR	Automatic compression release
AGM	Absorbed glass mat (battery)
Ah	Ampere-hour
BCM	Body control module
°C	Celsius (Centigrade)
CCA	Cold cranking amps
CI	Cubic inch
cm	Centimeters
cm ³	Cubic centimeters (cc)
CVO	Custom vehicle operations
DC	Direct current
DLC	Data link connector
DOM	Domestic
DT II	Digital Technician II
DTC	Diagnostic trouble code

Table 48. Acronyms and Measurement Symbols

ITEM	DEFINITION
ECM	Electronic control module
EFI	Electronic fuel injection
EHCUC	Electro hydraulic control unit
EITMS	Engine idle temperature management system
EHCUC	Electro hydraulic control unit
ETC	Electronic throttle control
EV	Electric vehicle
EVAP	Evaporative emissions control system
EVPT	Electric vehicle powertrain
EVSE	Electric vehicle supply equipment
°F	Fahrenheit
fl oz	Fluid ounce
ft	Feet
ft-lbs	Foot pounds
FTP	Flash to pass
g	Gram
gal	Gallon
GAWR	Gross axle weight rating
GND	Ground (electrical)
GPS	Global positioning system
GVWR	Gross vehicle weight rating
H-DSSS	Harley-Davidson smart security system
HCU	Hydraulic control unit
HDI	Harley-Davidson International

Table 48. Acronyms and Measurement Symbols

ITEM	DEFINITION
HHC	Hill hold control
HP	Horsepower
HV	High voltage
Hz	Hertz
IGN	Ignition light/key switch position
IM	Instrument module
IMU	Inertia measurement unit
in	inch
in ³	Cubic inch
in-lbs	Inch pounds
kg	Kilogram
km	Kilometer
km/h	Kilometers per hour
kPa	Kilopascal
kW	Kilowatt
L	Liter
lb	Pounds
LED	Light emitting diode
Li-ion	Lithium-Ion
LV	Low voltage
mA	Milliampere
mi	Mile
MIL	Malfunction indicator lamp
Min	Minimum
mL	Milliliter

Table 48. Acronyms and Measurement Symbols

ITEM	DEFINITION
mm	Millimeter
mph	Miles per hour
ms	Millisecond
Nm	Newton-meter
OBC	Onboard charger
oz	Ounce
P&A	Parts and Accessories
PA	Public address
Part No.	Part number
PIN	Personal identification number
PPE	Personal protective equipment
psi	Pounds per square inch
PTT	Push to talk
qt	Quart
RDRS	Reflex defensive rider systems
RESS	Rechargeable energy storage system
rpm	Revolutions per minute
SDS	Safety data sheet
SoC	State of charge
SoH	State of health
SW	Software
TCS	Traction control system
TCU	Telematic Control Unit
TPMS	Tire pressure monitoring system
USB	Universal serial bus

Table 48. Acronyms and Measurement Symbols

ITEM	DEFINITION
USB-C	Universal serial bus - type C
V	Volt
VAC	Volts of alternating current
VDC	Volts of direct current
VIN	Vehicle identification number
VR	Voice recognition
W	Watt
WSS	Wheel speed sensor
Wh	Watt-hour
WHIM	Wireless Headset Interface Module

H-D U.S.A., LLC TRADEMARK INFORMATION

Bar & Shield, Boom!, Breakout, Cruise Drive, CVO, Digital Tech, Digital Technician, Digital Technician II, Electra Glide, Evolution, Fat Bob, Fat Boy, Forty-Eight, FXDR 114, Glaze, Gloss, H-D, H-Dnet.com, Harley, Harley-Davidson, HD, Heritage Softail, Iron 1200, Iron 883, Low Rider, Milwaukee-Eight, Night Rod, Pan America, Profile, Reflex, Revolution X, Road Glide, Road King, Road Tech, Roadster, Screamin' Eagle, Seventy-Two, Slim, Softail, Sport Glide, Sportster, Street Bob, Street Glide, Street Rod, Sun Ray, Sunwash, SuperLow, Supersmart, SYN3, TechLink, TechLink II, TechLink 3, Tour-Pak, Tri Glide, Twin-Cooled, Ultra Classic,

and Harley-Davidson Genuine Motor Parts and Genuine Motor Accessories are among the trademarks of H-D U.S.A., LLC.

PRODUCT REGISTERED MARKS

Android, Apple, Alcantara S.p.A., Allen, Amp Multilock, Bluetooth, Brembo, CarPlay, City Navigator, Delphi, Deutsch, Dunlop, Dynojet, Fluke, G.E. Versilube, Garmin, Gunk, Heli-Coil, Hydroseal, Hylomar, iPhone, iPod, Kevlar, Lexan, Loctite, Lubriplate, Keps, K&N, Magnaflux, Marson Thread-Setter Tool Kit, MAXI fuse, Molex, Michelin, MPZ, Multilock, nano, NGK, Novus, Packard, Pirelli, Permatex, Philips, Pozidriv, Road Tech, Robinair, S100, Sems, Siri, SiriusXM, Snap-on, Teflon, Threadlocker, Torca, Torco, TORX, Tufoil, Tyco, Ultratorch, Velcro, X-Acto and XM Satellite Radio are among the trademarks of their respective owners.

PATENTS

Harley-Davidson products are covered by one or more United States and international patents or pending patent applications.

COPYRIGHT

ALL RIGHTS RESERVED.

©2020 H-D.

NOTES



Index

A

Accessories and Cargo Guidelines.....	3
Acronyms and Abbreviations.....	217
Adjust.....	44,169
Adjusting Steering Head Bearings.....	155
Adjustments, Suspension.....	46
AGM Battery.....	157
Air Filter, Inspecting.....	156
Alarm.....	67
Anti-lock Brake System (ABS) Identification.....	39

B

Bank Angle Lamp.....	172
Battery.....	69,157,161
Before You Ride.....	33
Brake.....	72
Brake Fluid Level , Checking.....	145
Brake Fluid, Changing.....	145
Brake Pads and Discs, Inspecting.....	143
Brakes.....	182
Break-in.....	34,135
Break-in Maintenance.....	135
Bulb.....	169

Bulb, Replacement LED Tail Lamp.....	173
Bulb, Replacement LED Turn Signal.....	173

C

California Evaporative Emission Controls.....	184
Catalytic Converter.....	37
Center Stand.....	45
Chain.....	148
Changing Engine Oil.....	140
Charging.....	157
Charging Battery.....	157
Checking Brake Fluid Level and Changing Brake Fluid....	145
Checking Clutch and Brake Controls.....	147
Checking Engine Oil.....	138
Checking Systems for Leaks or Abrasions.....	145
Checklist.....	33
Clean.....	123,124,129,132,157
Cleaning.....	124,129
Clutch.....	151
Clutch and Brake Controls, Checking.....	147
Controls.....	24,72
Coolant.....	29,152,181
Coolant, Replace.....	154
Cooling System.....	181

Index

Copyright.....	219
Cover.....	164
Customer service.....	1

D

Dealer Locator.....	185
Dealer Locator Phone Number.....	185
Disposal and Recycling.....	136

E

Electrical System.....	181
Electronic Suspension.....	49
Engine.....	34, 109, 179
Engine OFF/RUN Switch.....	91
Engine Oil.....	137, 138, 140
Engine Oil and Filter.....	140
EPA Noise Regulations.....	184

F

Factory Replacement Parts.....	183
--------------------------------	-----

Fairing.....	168
Fill.....	35
Fob.....	59
Fork Maintenance.....	135
Front Fork, Maintaining.....	155
Fuel.....	35, 37
Fuel Cap Lock, Lubricating.....	156
Fuses.....	69, 175
Fuses and Relays.....	69

G

Gasoline.....	37
Gear Shift.....	72
Genuine Motor Parts and Accessories.....	123

H

Hand Control Modules.....	86, 91
Hazard Warning 4-Way Flashers.....	64
Headlight.....	169
Heated Gear.....	107

Index

I

Importing a Motorcycle.....	186
Indicators.....	79
Infotainment.....	95
Infotainment System.....	95
Inspect.....	157
Inspecting Air Filter.....	156
Inspecting Brake Pads and Discs.....	143
Inspection.....	157
Instruments.....	75

J

Jiffy Stand.....	44
------------------	----

K

Key.....	59
Kick Stand.....	44

L

Labels.....	17
-------------	----

Leaks or Abrasions, Checking Systems for.....	145
Leather.....	132
Leather Care.....	132
Low Beam Switch.....	86
Lubricating Fuel Cap Lock.....	156
Lubrication, Miscellaneous.....	148

M

Maintaining Front Fork.....	155
Maintenance.....	135, 137, 138, 140, 151, 155, 155, 183, 211
Maintenance, Preparing the Motorcycle for.....	135
Manual.....	1
Manual Suspension.....	51
Mirror Adjustment.....	44
Mirrors.....	44
Miscellaneous Lubrication.....	148
Models and Features.....	24

N

National Highway Traffic Safety Administration.....	185
National Highway Traffic Safety Administration (NHTSA).....	185
Noise Control System.....	13

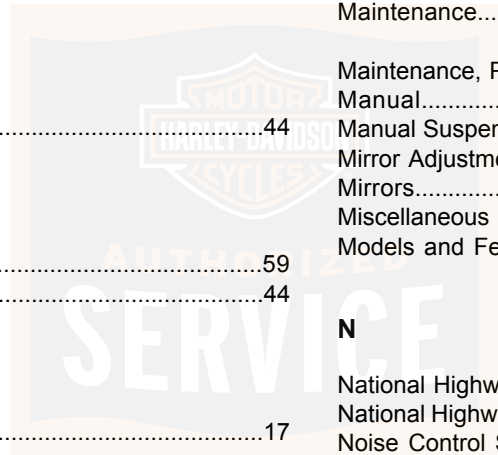

Index

O		Rider Safety Enhancements.....	109
		Rules of the Road.....	12
Oil.....	137		
Oil Cooler.....	142		
Oil Level.....	138		
Operation.....	44, 108, 109, 109		
Owner Contact Information.....	186		
P		S	
Patents.....	219	Safe Operating Rules.....	3
Polishing.....	129	Safety.....	3, 17, 157
Power Disconnect.....	69	Safety Symbols, Definitions.....	13
Pre-Ride Checklist.....	33	Seat.....	173
Preparing the Motorcycle for Maintenance.....	135	Security System.....	59, 59, 62, 64, 67, 68, 68, 69, 69, 70
Primary Chaincase.....	29	Service Records.....	211
 		Shifting Gears.....	117
R		Shock Absorbers.....	155
Radiator, Clean.....	153	Side cover.....	164
Recommended Cleaning Products.....	124	Side Covers.....	164
Registered Marks.....	219	Skid Plate.....	165
Ride Modes.....	100	Skid Plate Remove and Install.....	165
		Smart Security System.....	69, 69, 70
		Spark Plug Replacement.....	155
		Spark Plugs.....	155
		Specifications.....	29, 137
		Start Switch.....	91
		Starting the Engine.....	109

Index

Steering Head Bearings, Adjusting.....	155
Stopping the Engine.....	109
Storage.....	33
Storing.....	33,157
Storing.....	133
Suspension Adjustment.....	46
Switch.....	72,86,91

T

Tail Lamp Bulb Replacement LED.....	173
Throttle.....	72
Tire.....	123
Tires.....	123
Tires, Checking Pressure and Inspecting.....	39
Traction Control.....	115
Traction Control (TC) Description.....	115
Trademarks.....	219
Transmission.....	29,181
Transport Mode.....	68
Troubleshooting.....	70,179,181,181,182
Turn Signal Bulb Replacement LED.....	173

U

USB Port.....	106
---------------	-----

V

Vehicle Identification Number (VIN).....	21
Vehicle Storage.....	33
Vinyl.....	132
Vinyl Care.....	132
Voltage test.....	157

W

Warranty.....	183,185,186
Warranty Repair Work.....	185
Washing.....	129
Wheels.....	123
Widgets.....	100

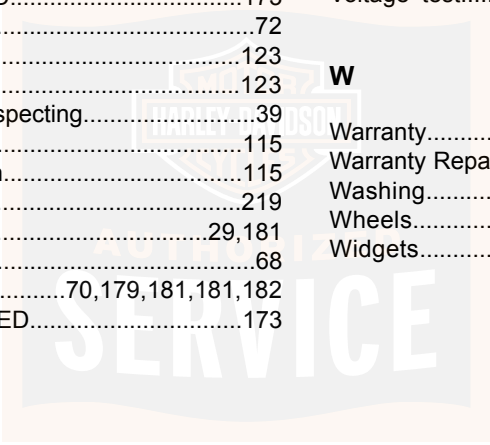

NOTES

