



INSTRUCTIONS

J05615

2026-05-27



DYNA RIDER FOOTBOARD KIT

GENERAL

Kit Number

50500247

Models

For model fitment information, see the P&A Retail Catalog or the Parts and Accessories section of www.harley-davidson.com (English only).

Additional Parts Required

Separate purchase of LOCTITE® 243 Threadlocker and Sealant - Blue (Harley-Davidson Part Number 99642-97) is required for proper installation of this kit. LOCTITE can be purchased from any Harley-Davidson Dealer.

▲ WARNING

Rider and passenger safety depend upon the correct installation of this kit. Use the appropriate service manual procedures. If the procedure is not within your capabilities or you do not have the correct tools, have a Harley-Davidson dealer perform the installation. Improper installation of this kit could result in death or serious injury. (00333b)

NOTE

This instruction sheet references service manual information. A service manual for your model motorcycle is required for this installation and is available from a Harley-Davidson Dealer.

Kit Contents

See Figure 3, Figure 4, Figure 5 and Table Reference.

INSTALLATION

Shifter Assembly

- See service manual and disconnect main fuse.
- See service manual and remove the left side rider footrest assembly. Discard the footrest and fasteners.
- See Figure 4. Remove plugs from forward frame footboard mount (E) and discard plugs.
- See Figure 4. Remove the foot shifter lever (A) and shifter peg (D). Save the foot shifter lever and shifter peg and hardware for future installation.
- See Figure 3. See service manual and remove the outer cover assembly (A) and inner cover assembly (B).
- See Figure 1. Before removing the gear shifter lever (1):
 - Using a marking tool, draw a location marking (4) on the end of the splined shaft (2) across from the casting split (3). This will allow the new gear shifter lever to be installed in the same orientation as the old lever.
 - After marking the gear shifter lever orientation, loosen the lever bolt (5) and remove the gear shifter lever (1).
 - Discard the gear shifter lever and lever bolt.
 - See Figure 4. From the kit, install the new gear shifter lever (11) and bolt (12) onto the splined shaft in the same orientation as the old shifter lever.
 - See Figure 1. Tighten the lever bolt (5) to 24.4–29.8 N·m (18–22 ft-lbs).
- See Figure 4. Install the front and rear footrest brackets (4 and 5) to the frame using the buttonhead TORX® screws (2). Tighten screws.
Torque: 33.9–47.5 N·m (25–35 ft-lbs)



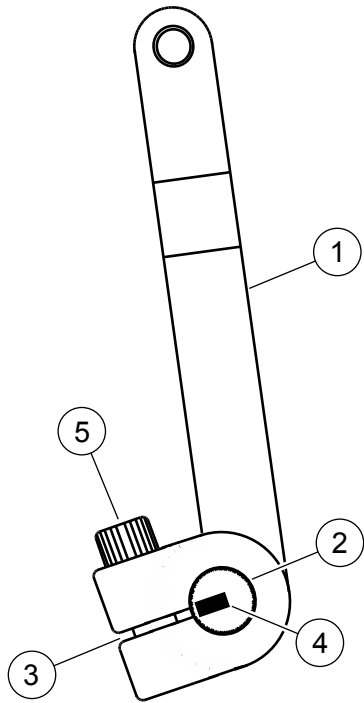

1. Gear shifter lever
2. Splined shaft
3. Casting split
4. Location marking
5. Lever bolt

Figure 1. Gear Shifter Lever Orientation

8. See Figure 4. Install the front inner gear shifter (7) and washer (6) to inside of the front footboard bracket.
9. Install the previously saved gear shifter (A) with a coat of light lubricant. Install washer (B), screw (C), and shifter peg (D) to the gear shifter. Tighten screw (C).
Torque: 9.5–12.2 N·m (7–9 ft-lbs)
10. Using a small amount of Loctite 243, install the new shifter rod assembly (10) onto the gear shifter lever (11). Also install washer (9) and acorn nut (8) to inner gear shift assembly (7). Tighten acorn nut (8) and rear of shift linkage (10).
Torque: 10.8–16.3 N·m (8–12 ft-lbs)
11. Tighten rear gear shifter lever threaded swivel stud. After all shifter components are installed, move shifter through entire range of motion and check for interference with other components.
12. See Figure 3. Put inner primary cover (B) and primary cover (A) in position and check for proper clearance with shifter linkage components.
13. See Figure 2. Clean the area around primary cover (1) hole, removing all dirt, oil and grease. Apply Loctite 243 around opening (2). Insert primary hole plug (4) into opening. Remove any excess adhesive from surface. Allow Loctite to cure for 24 hours before operating vehicle.
14. Moisten four rubber anchors on bottom of new footboard pad with soapy water.

15. See Figure 5. Place pad (1) into position on footboards (4). From bottom of footboards, use pliers to pull rubber anchors through holes in footboards.
16. See Figure 3. See service manual. Install primary cover using new gaskets from the kit.

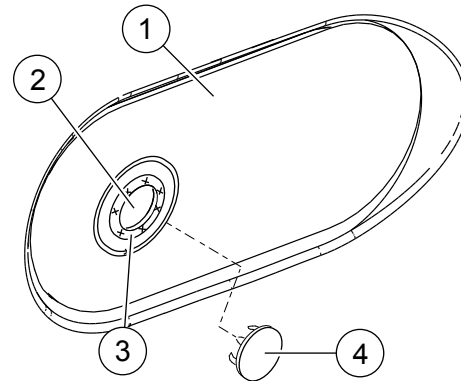

1. Primary cover
2. Shifter shaft hole (original position)
3. Loctite 243 area (X)
4. Primary hole plug

Figure 2. Outer Cover Plug Installation

17. See Figure 4. Install footboards (14) to brackets (4 and 5) using shoulder bolts (1) and flange nuts (3). Tighten screws.
Torque: 20–27 N·m (15–20 ft-lbs)

Rear Brake and Footboard Assemblies

NOTE

It may be helpful to remove the exhaust to access the rear brake components. Refer to the service manual for the exhaust removal.

1. See Figure 5 and service manual. Remove the right side rider footrest fasteners. Discard the fasteners.
2. Loosen the brake rod jam nut (15) at the rear brake master cylinder.

NOTE

The master cylinder piston has flats for a wrench. Turn the flats on the piston to unscrew the brake rod from the master cylinder.

3. Unscrew the master cylinder piston from the stock brake rod.
4. Remove and discard the stock brake rod, footrest and brake pedal assembly.
5. Remove the rear bracket footrest hole plugs and discard.
6. Fasten the new front (8) and rear (16) footboard supports to the frame using TORX screws (2). Tighten screws.
Torque: 43–50 N·m (32–37 ft-lbs)

7. Install the jamnut (15) all the way onto the new brake rod (14).

8. Fasten the brake rod to the master cylinder piston.

NOTE

When installing the brake rod make sure that brake rod does not have any interference from the clamps on the exhaust. The clamps could scrape the paint on the brake rod.

9. Coat the pivot shaft (12) with a light coating of lubricant. Install the brake pedal (11) to the front footboard support (8) with long TORX screw (5), foot brake lever cap (6), pivot shaft (12), clevis pin (9) and circular cotter (10).

10. With a wrench on the master cylinder piston flats, turn the piston onto the brake rod until the brake pedal is elevated to an effective rider angle, using at least half the threads available on the brake rod. Tighten the jam nut against the master cylinder piston.

11. Install brake pedal pad (13). Verify brake pedal and rod travel through entire range of motion without binding or interference.

12. Place the footboard into position between brackets and install shoulder bolts (3), so that the flange locknuts (7) will be on the inboard side.

13. Install flange locknuts onto shoulder bolts and tighten.

Torque: 6.8–9 N·m (60–80 in-lbs)

▲ WARNING

After repairing the brake system, test brakes at low speed. If brakes are not operating properly, testing at high speeds can cause loss of control, which could result in death or serious injury. (00289a)

14. Return the motorcycle to service:

- a. Refer to service manual and install main fuse.
- b. Test lights and brakes. If the brakes feel spongy, bleed the system.

SERVICE PARTS

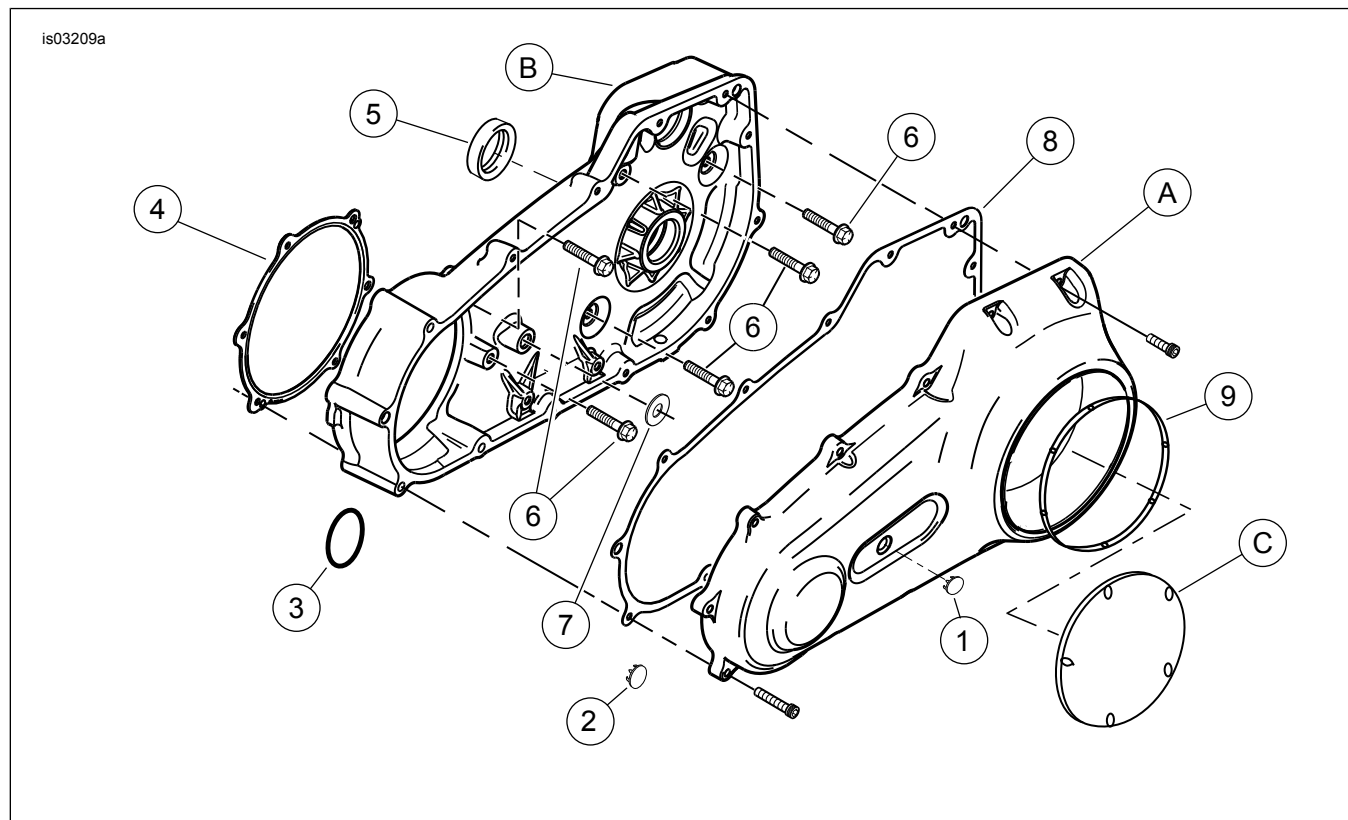

Figure 3. Primary Chaincase Cover and Housing Components

Table 1. Service Parts Table

Item	Description (Quantity)	Part Number
1	Hole plug	90357-89
2	Hole plug, black	6943
3	O-ring	27444-00Y
4	Primary gasket, crankcase housing	34934-06
5	Inner primary seal	12052C
6	Seal bolts, 5/16 inch (5)	Not Sold Separately

Table 1. Service Parts Table

Item	Description (Quantity)	Part Number
7	Tower gasket	63869-06
8	Primary cover gasket	60547-06
9	Clutch cover seal	Not Sold Separately
Items mentioned in text, but not included in kit:		
A	Primary cover	
B	Inner primary cover assembly	
C	Clutch cover	

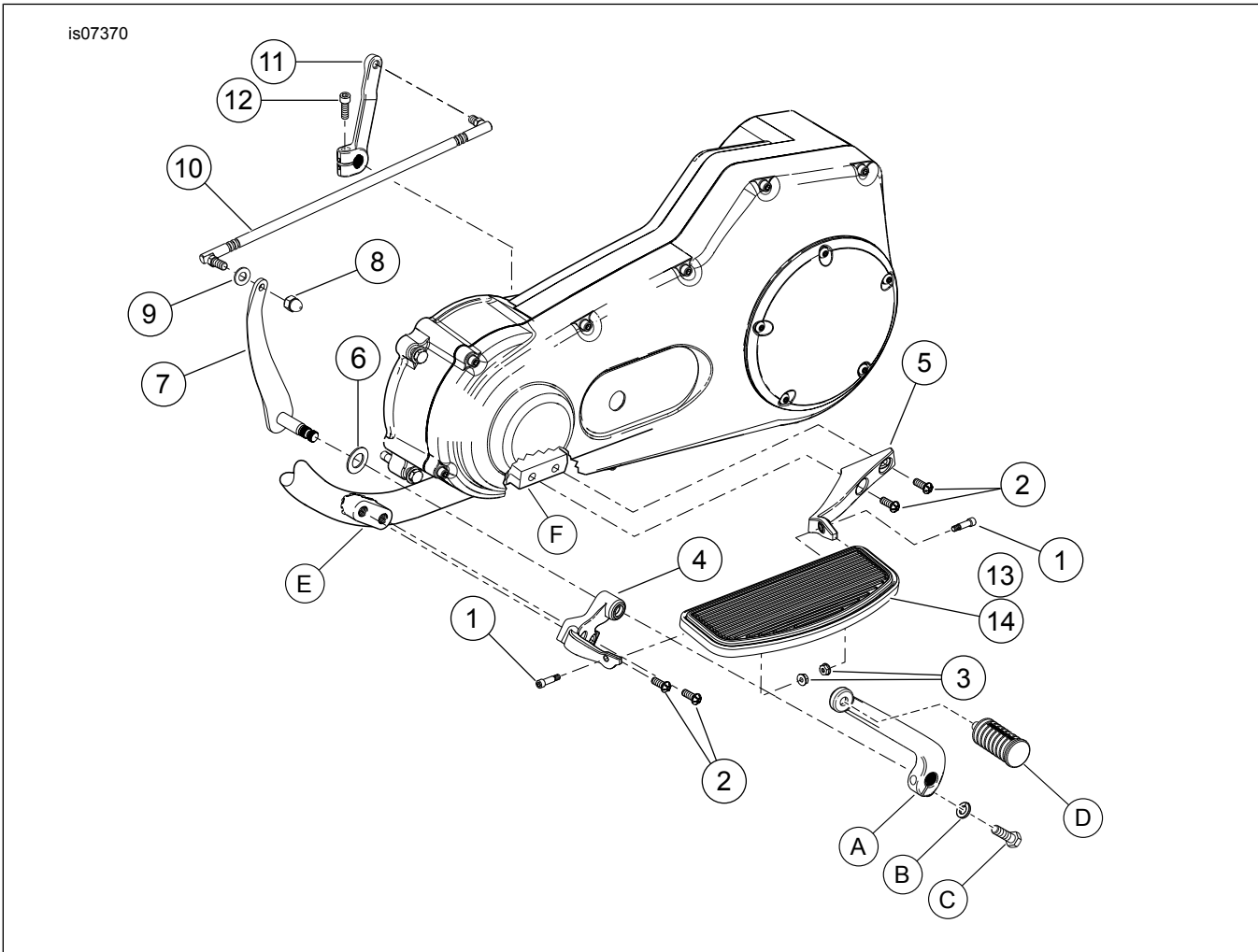

Figure 4. Dyna Rider Footboard Kit

Table 2. Service Parts Table

Item	Description (Quantity)	Part Number
1	Shoulder bolt (2)	10500023
2	Button head TORX screw .375-16 x 1.00 (4)	4512A
3	Flange nut (2)	7354
4	Right front footboard bracket	54172-12
5	Left rear footboard bracket	54173-12
6	Spring washer	34625-90
7	Inner gear shift lever assembly	33789-12
8	Acorn nut	7736
9	Plain washer, type A	6702
10	Shift rod assembly	34887-06
11	Gear shifter lever	33900004
12	Hex socket head cap screw (lever bolt)	856A
13	Footboard pad	50614-06
14	Footboard assembly (with pad)	50621-06
Items mentioned in text, but not included in kit:		

Table 2. Service Parts Table

Item	Description (Quantity)	Part Number
A	Foot shifter lever	
B	Washer	
C	Bolt	
D	Shifter peg	
E	Forward frame footboard mount	
F	Rear frame footboard mount	

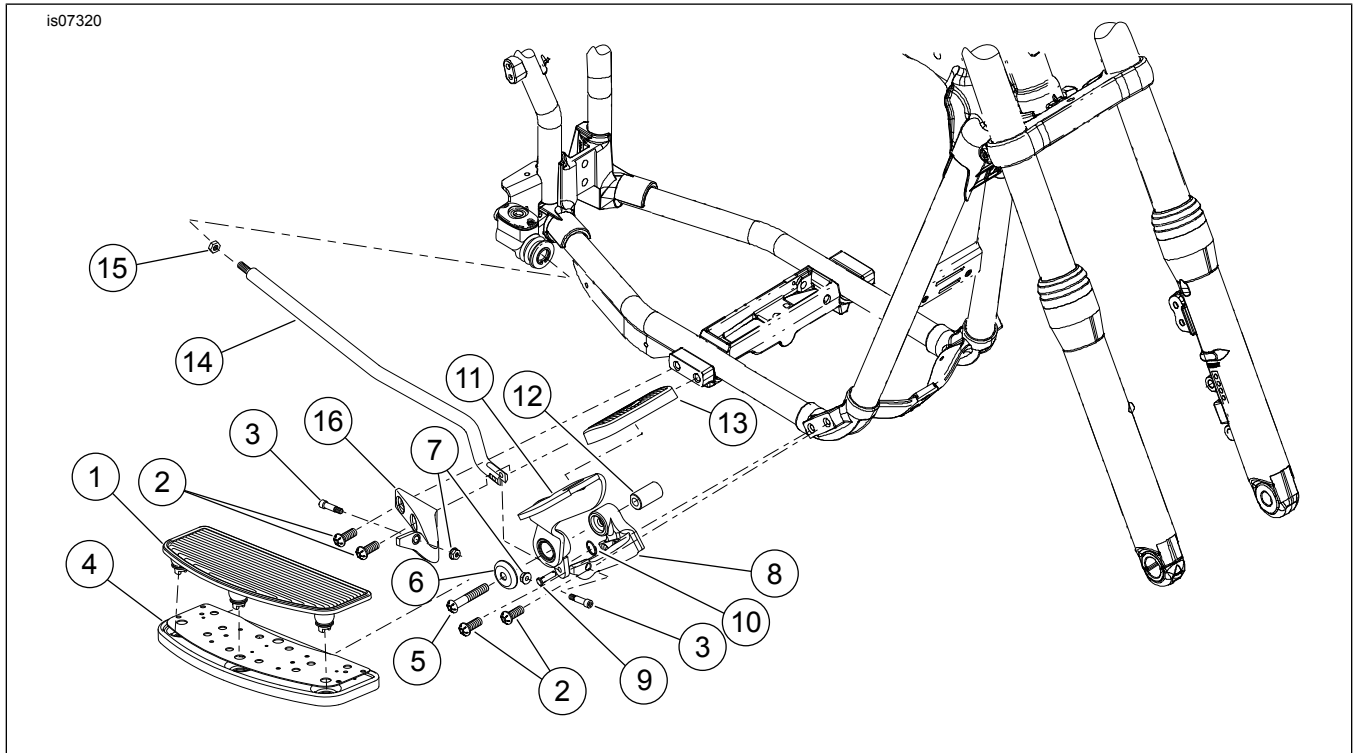

Figure 5. Dyna Rider Footboard Kit

Table 3. Service Parts Table

Item	Description (Quantity)	Part Number
1	Footboard pad	50614-06
2	Button head TORX screw, .375-16 x 1.00 (4)	4512A
3	Shoulder bolt (2)	10500023
4	Footboard assembly (with pad)	50621-06
5	Button head TORX screw, .375-16 x 2.25	4997
6	Foot brake lever cap	38160-12
7	Flange nut (2)	7354
8	Right front footboard support	54172-12
9	Clevis pin	42460-80B
10	Cotter, circular	51938-04
11	Rear brake pedal	38157-12
12	Pivot shaft	42665-03
13	Brake pedal pad	42416-06
14	Rear brake pushrod	Not Sold Separately
15	Hex jam nut	7744
16	Right rear footboard support	54165-12