



INSTRUCTIONS

J06604

2026-01-13



DERBY COVER KIT

GENERAL INFORMATION

Table 1. General Information

Kits	Suggested Tools	Skill Level ⁽¹⁾
25700934, 25700958, 25700959, 25700960, 25700961, 25700962, 25700963, 25700964, 25700965, 25700966, 25700967, 25700968, 25700969, 25700970, 25700971, 25700972, 25700973, 25700976, 25701023, 25701063, 25701088, 25701407, 25701408, 25701175, 25701177, 25701179, 25701209, 25701521, 25701522, 25701532, 25701553, 25701633, 25701635, 25701784	Safety Glasses, Torque Wrench	

(1) Tightening to torque value or other moderate tools and techniques required

KIT CONTENTS

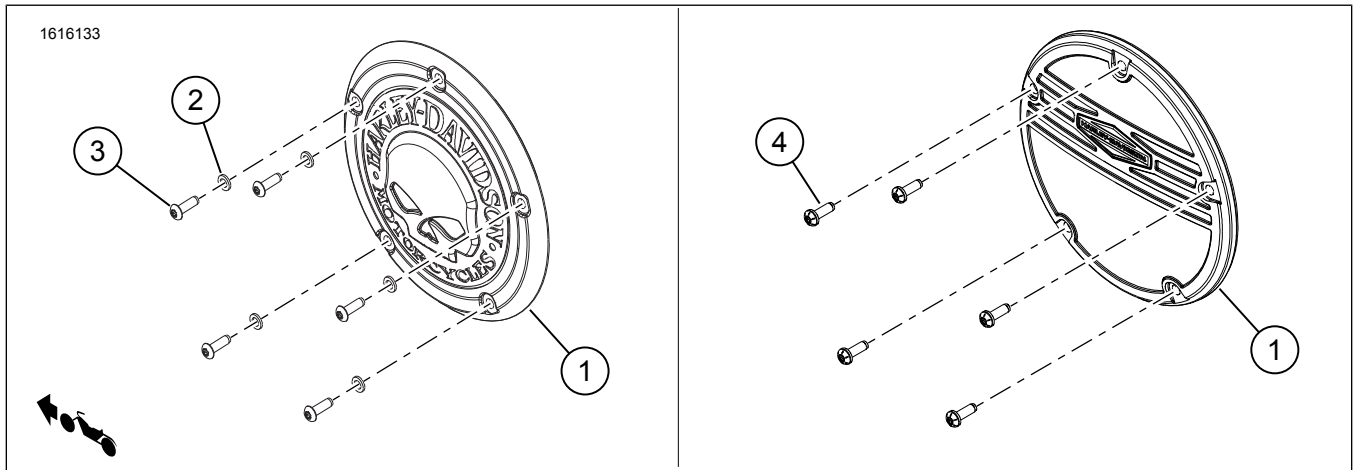

Figure 1. Kit Contents: Derby Cover Components

Table 2. Kit Contents: Derby Cover Components

<input checked="" type="checkbox"/>	Item	Qty	Description	Part No.	Kit Number
<input type="checkbox"/>	1	1	Clutch cover	Not sold separately	
<input type="checkbox"/>	2	5	Washer, flat	10300155	Kits: 25700958, 25700959, 25700965, 25700966, 25700969, 25700973, 25700961, 25700962, 25701063, 25701175, 25701408
<input type="checkbox"/>		5	Washer, flat, black oxide	10300161	Kits: 25700963, 25700964, 25700967, 25700970, 25700971, 25700972, 25700976, 25701023, 25701088, 25701407, 25701177, 25701521, 25701532, 25701633, 25701635, 25701784
<input type="checkbox"/>	3	5	Screw, button head, TORX®, chrome	10200672	Kits: 25700958, 25700959, 25700969, 25700973, 25700961, 25701063, 25701408, 25701175
<input type="checkbox"/>		4	Screw, button head, TORX®, chrome		Kit: 25700962
<input type="checkbox"/>		1	Screw, button head, TORX®, chrome	10200714	Kit: 25700962
<input type="checkbox"/>		4	Screw, button head, TORX®, black zinc	10200698	Kits: 25700963, 25700964
<input type="checkbox"/>		5	Screw, button head, TORX®, black zinc		Kits: 25700971, 25701177, 25701407, 25701521, 25701532, 25701023, 25701088, 25701633, 25701635, 25701784
<input type="checkbox"/>		1	Screw, button head, TORX®, black zinc	10200715	Kits: 25700963, 25700964
<input type="checkbox"/>		5	Screw, button head, TORX®, black oxide	10200699	Kits: 25700967, 25700970, 25700972, 25700976
<input type="checkbox"/>		6	Screw, socket head, stainless	10200659	Kits: 25700965, 25700966
<input type="checkbox"/>		5	Screw, socket head, zinc	10200700	Kits: 25700965, 25700966
<input type="checkbox"/>	4	5	Screw with washer, button head, TORX®	10200644	Kit: 25701209

NOTE

Verify all contents are present in the kit before installing or removing items from vehicle.

GENERAL

Instruction sheet is also available electronically. To verify you are using the most current version available, do one of the following:

- Go to h-d.com/isheets
- Scan QR code in upper left corner of the instruction sheet

NOTE

This instruction sheet **may have a Supplemental Video** to assist installer in clarifying a certain part of the assembly. A linked video would be located at the end of this instruction sheet.

Models

For model fitment information, see the Parts and Accessories (P&A) Retail Catalog or the Parts and Accessories section of www.harley-davidson.com.

Verify that the most current version of the instruction sheet is used. It is available at: h-d.com/isheets

Contact Harley-Davidson Customer Support Center at 1-800-258-2464 (U.S. only) or 1-414-343-4056.

Installation Requirements

⚠ WARNING

Rider and passenger safety depend upon the correct installation of this kit. Use the appropriate service manual procedures. If the procedure is not within your capabilities or you do not have the correct tools, have a Harley-Davidson dealer perform the installation. Improper installation of this kit could result in death or serious injury. (00333b)

NOTE

This instruction sheet references service manual information. A service manual for the year and model motorcycle is required for this installation and is available from:

- A Harley-Davidson dealer.
- H-D Service Information Portal, a subscription-based access available for most 2001 and newer models. For more information see *Frequently ask questions about subscriptions*.

These items are available at your local Harley-Davidson dealership.

- *Separate purchase of Clutch Cover Gasket may be required.*

REMOVE

1. Remove Original Equipment (OE) screws and washers. Set aside.
2. Inspect quad ring gasket. Replace if necessary.
3. Verify quad ring is properly seated in groove of primary cover.

INSTALL

All Kits Except 25701209

NOTE

- Kit Number 25701063, 25701553: Bare Aluminum Wheel Protectant Wipes (Part No. 93600063) can be applied to "RideFree" text for added corrosion protection.
- Kit Numbers 25700962, 25700963 and 25700964: One longer screw goes into 2 o'clock position.

If reusing OE screws, clean threads of screw and chase hole. Apply **LOCTITE 243 MEDIUM STRENGTH THREADLOCKER AND SEALANT (BLUE)** (99642-97) to screws.

1. Figure 1 Install **new** cover (1).
2. Install washers (2) and screws (3).
3. Figure 2 Tighten screws (3) in a star pattern.
Torque: 2.8–3.9 N·m (25–35 **in-lbs**)

NOTE

PN 25700934, 25700960, 25700968, 25701179, 25701522 and 25701553 uses the OE screws, which are PN 10200644. Apply the 2.8-3.9 Nm torque.

- a. **Kits: 25700965 and 25700966.** Tighten screws (Part No. 10200659).
Torque: 1.69–2.25 N·m (15–20 **in-lbs**)

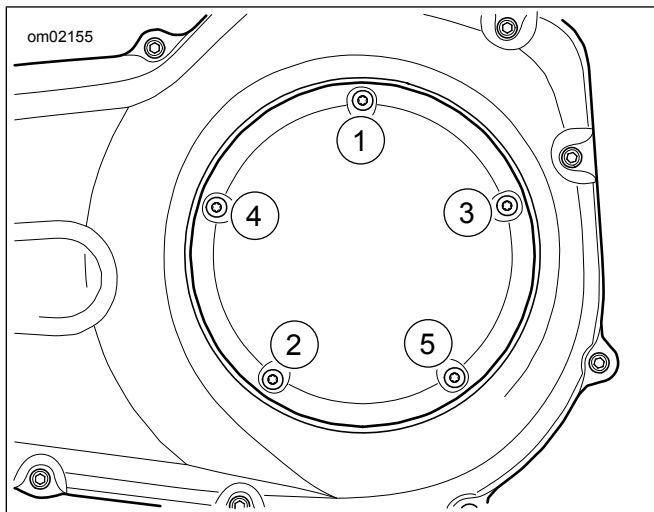

Figure 2. Clutch Cover Tightening Sequence

Kit 25701209

NOTE

- Bare Aluminum Wheel Protectant Wipes (Part No. 93600063) can be applied to exposed aluminum ribs for added corrosion protection.

1. Figure 1 Apply threadlocker to threads of screws (4).
Consumable: **LOCTITE 243 MEDIUM STRENGTH THREADLOCKER AND SEALANT (BLUE)** (99642-97)
2. Install **new** cover (1).
3. Install screws (4).
4. Figure 2 Tighten screws (4) in a star pattern.
Torque: 2.8–3.9 N·m (25–35 **in-lbs**)