



Service Tool Instructions



BOSCH

Bosch Automotive Service Solutions

655 Eisenhower Drive
Owatonna, MN 55060
Phone 800-345-2233
Fax 586-578-7375

REV. 08-16-2017

Instruction Sheet ID: -J06645

HD-48498-A ACR SOLENOID SOCKET

General

See Figure 1 and Figure 2. Use the ACR Solenoid Socket (Part No. HD-48498-A) to remove/install an Automatic Compression Release (ACR) in a cylinder head of 2007 and later Screamin' Eagle® engines. The ACR may be serviced with the engine in the chassis. See "Stripping Motorcycle for Service" and "Top End Overhaul" procedures found in the service manual.

NOTE

A service manual and service supplement for the model motorcycle is available from a Harley-Davidson Dealer.

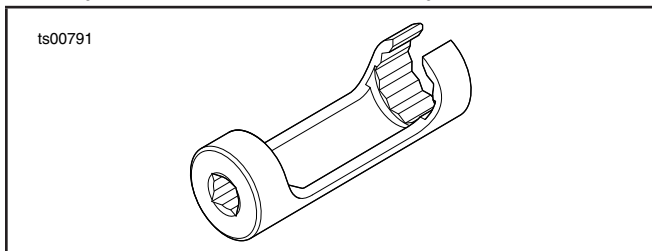

Figure 1. ACR Solenoid Socket (HD-48498-A).

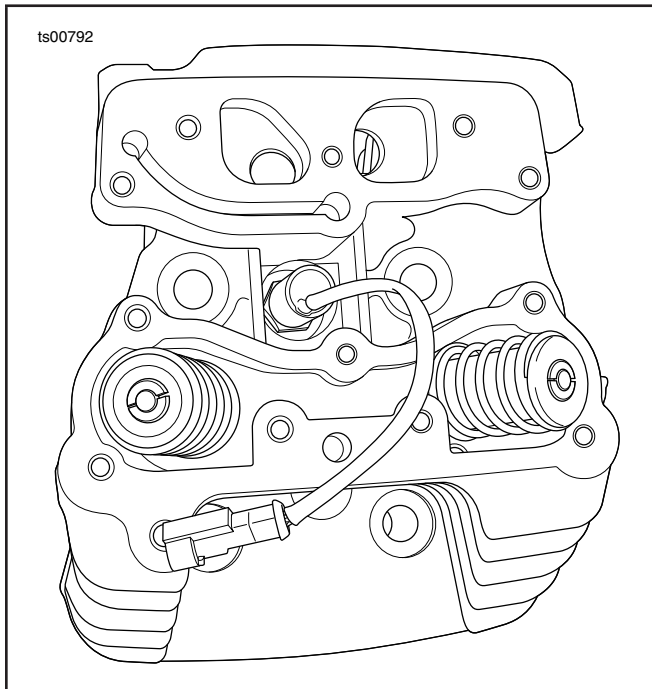

Figure 2. ACR in cylinder head.

ACR Removal

1. Disassemble the rocker covers and the rocker housing. See the service manual for top end disassembly procedures.
2. Separate the ACR connector pin housings from the socket housings on the main wiring harness.
3. To prevent debris entering the combustion chamber of engines with the cylinder head installed, clean the socket well around the ACR.
4. See Figure 3. With ACR harness in slot in ACR Solenoid Socket (HD-48498-A), fit socket to ACR.

NOTE

The wire harness **must** turn with the socket. If it does not, the harness will be damaged when the ACR is turned in or out of the cylinder head.

5. Turn socket counterclockwise to loosen ACR.
6. When ACR turns freely, remove socket and turn ACR out by hand.

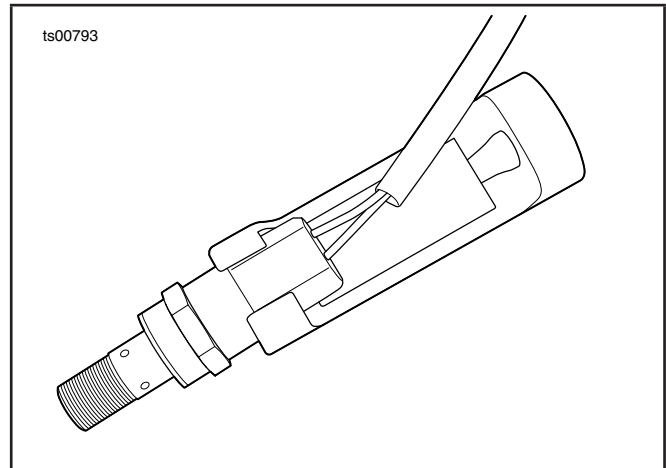

Figure 3. ACR in ACR solenoid socket.

ACR Installation

1. See Figure 4. Verify that the copper seal washer (1) is in place on the ACR.
2. Identify a circumference (2) around the threads of the ACR a third of the way up from the valve.

Form # HD-48498-A-5 Rev B.

3. See Figure 5. Apply three dots of Loctite 246 Threadlocker (blue) Medium Strength/High Temperature equally spaced around the circumference of the bottom third of threads.
4. To prevent cross threading, install and finger tighten.
5. Using the ACR Solenoid Socket (HD-48498-A), tighten to the proper torque. See appropriate service manual for specifications.
6. Before installing the rocker housings, route the wire harness toward the inside of the cylinders.
7. Mate the pin housings of the ACR connectors front and rear to the socket housings on the main wiring harness.
8. Assemble upper rocker box, gasket and rocker cover. See the service manual for top end assembly procedures.

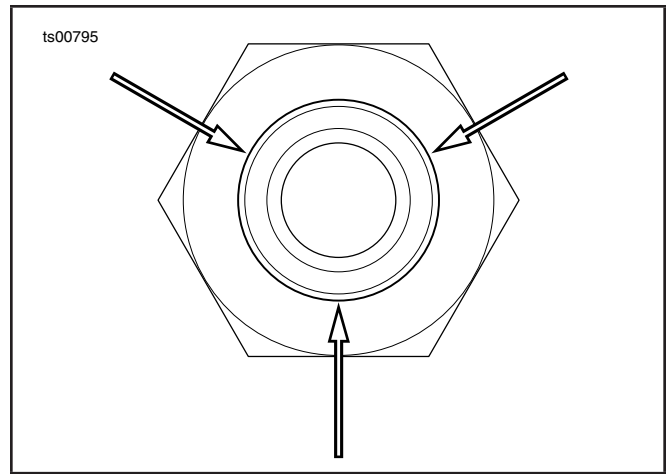

Figure 5. Three dots of Loctite 246 Threadlocker Medium Strength/High Temperature.

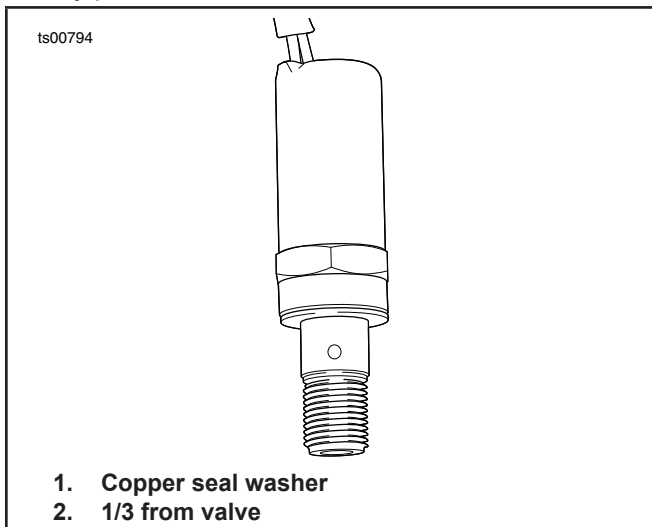

Figure 4. Typical ACR.