



INSTRUCTIONS

-J01589

REV. 1-20-00

Kit Number 34535-00

BILLET STYLE LEVER KIT, HEEL/TOE

General

Fits 1988 and later Touring models; and 1986 and later FL models.

See Service Parts illustration below for items contained in this kit.

Installation

1. Before removing original shift levers, note the orientation. You will want to replace them at the same position and angle.
2. Remove the socket head screws clamping the shift levers onto the splined shaft. Remove the original equipment shifter pegs for reattachment to the new levers if desired. Remove original equipment shift levers.

NOTE

The heel and toe billet shift levers have counter-bored screw holes positioned at the top of each lever for ease of installation. Socket head cap screws are installed from the top. See Figure 1.

3. Install the billet shifters as follows:
 - a. Begin with the toe shifter lever (2), positioning it so counter-bored screw hole is up. Adjust lever position to desired angle and slide it onto the splined shaft, aligning screw hole with notch on

shaft.

- b. Install the heel shift lever (1) in the same manner, making sure counter-bored screw hole faces up and position and angle are correct.
- c. Add a few drops of Loctite 242 (blue) to the socket head screws (3), and insert into counter-bored holes. Tighten to 8 ft-lbs (11 Nm).

4. Install shifter pegs onto new shift levers.

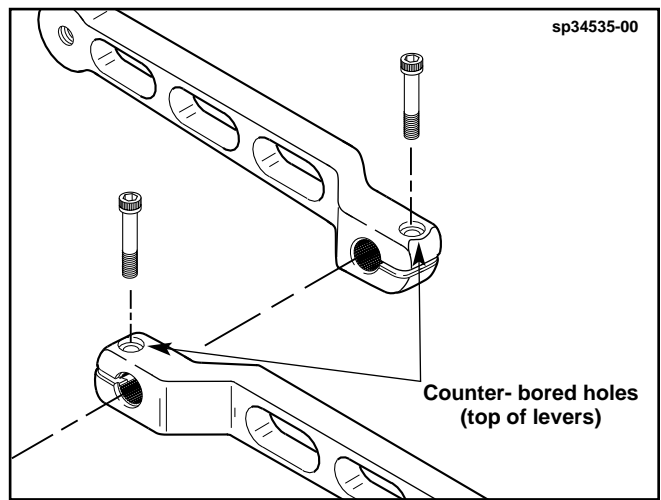

Figure 1. Socket Head Screw installation and Counter-Bored Holes



Service Parts

Part No. 34535-00

Date 6/99

Billet Style Lever Kit, Heel/Toe

sp34535-00

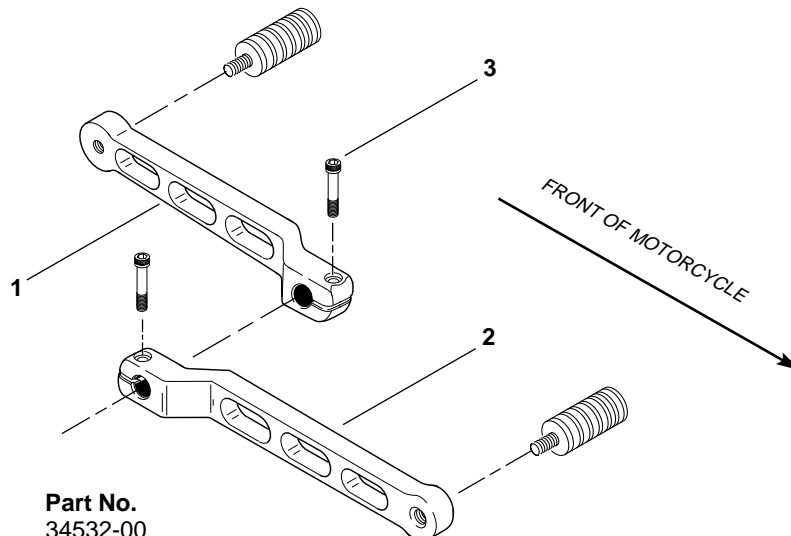

Item	Description	Part No.
1.	Billet shift lever (heel)	34532-00
2.	Billet shift lever (toe)	34568-00
3.	Hex socket head cap screw	94312-91T