



INSTRUCTIONS

-J03322

REV. 02-11-2005

Kit Number 33136-04 and 33137-04

SCREAMIN' EAGLE® FLHT 6-SPEED TRANSMISSION

General

The Screamin' Eagle FLHT 6-Speed Transmission kit fits 2002 and later Harley-Davidson® Touring model motorcycles.

Kit No.	Description
33136-04	Silver
33137-04	Black

Gear	5-Speed	6-Speed
1st	3.210	3.210
2nd	2.109	2.209
3rd	1.572	1.572
4th	1.226	1.226
5th	1.000	1.000
6th	NA	0.885

Table 1. Transmission Ratios

An additional kit for the side cover will be required. The kit number depends on if the motorcycle is using the existing clutch cable or is being converted to a hydraulically actuated clutch.

Kit No.	Description
38752-04	SE 6-Speed Cable Clutch Side Cover and Release Pushrod Kit
45033-03A	Hydraulic Clutch Kit - black
45383-03A	Hydraulic Clutch Kit - chrome
38753-04	SE 6-Speed Hydraulic Side Cover & Release Kit

See the Service Parts illustration for a list of service parts in this kit.

Required Service Parts and Tools

Installation of this kit will require additional service parts and supplies. Specialized tools will include Hose Clamp Pliers (HD-41137) and Hose Clamp Pliers (HD-97087-65B).

WARNING

The rider's safety depends upon the correct installation of this kit. If the procedure is not within your capabilities or you do not have the correct tools, have your Harley-Davidson dealer perform the installation. Improper installation of this kit could result in death or serious injury. (00308a)

NOTE

This instruction sheet references Service Manual instructions. A Service Manual for your model motorcycle is available from any Harley-Davidson dealer.

Installation

Prepare the Motorcycle for Service

1. Mount the motorcycle on a suitable lift.
2. Follow Service Manual instructions given to remove the seat.

WARNING

To prevent accidental vehicle start-up, which could cause death or serious injury, disconnect battery cables (negative (-) cable first) before proceeding. (00307a)

WARNING

Disconnect negative (-) battery cable first. If positive (+) cable should contact ground with negative (-) cable connected, the resulting sparks can cause a battery explosion, which could result in death or serious injury. (00049a)

3. Disconnect the battery cables, negative (-) cable first:
 - a. Remove bolt and negative (-) cable.
 - b. Remove bolt and positive (+) cable.

Access the 5-Speed Transmission

1. Place a container under the engine, remove the engine and transmission lubricant drain plugs to drain engine and transmission fluids.
2. To access the existing 5-speed transmission, follow the Service Manual instructions in the following sections:
 - a. SADDLEBAGS, REMOVAL
 - b. EXHAUST SYSTEM, REMOVAL

NOTE

The right muffler and crossover pipe can be removed in 1 piece and the left muffler and the front and rear header pipes can be removed in 1 piece. Refer to the Service Manual Section REMOVING ENGINE FROM CHASSIS for instructions.

- c. REAR WHEEL, REMOVAL

NOTE

Position a jack with a wooden block under the engine and transmission oil pan to support the weight of the 5-speed transmission.

- d. REAR SWINGARM, REMOVAL
- e. STARTER, REMOVAL
- f. CLUTCH RELEASE COVER

Remove the Primary Chaincase

Follow the Service Manual PRIMARY CHAINCASE, REMOVAL instructions to remove the cover, the primary chain, clutch, engine compensating sprocket, chain tensioner assembly, alternator and starter drive mechanism, and the primary chaincase.

Remove the 5-Speed Transmission

1. Remove the locknut, lockwasher and flat washer to separate the the shift rod from the 5-speed transmission shifter arm.
2. Remove oil hose cover and oil hoses at the crankcase.
 - a. Remove screws and cover.
 - b. Use side cutters to remove clamps on crankcase end of oil supply, return and crankcase breather hoses.
3. See Figure 1. Locate vehicle speed sensor and remove screw and the sensor from the existing transmission case.
4. See Figure 2. Remove connectors from neutral switch.
5. See Figure 3. Remove the fasteners from the transmission exhaust bracket.
6. Remove the 4 bolts and washers connecting the transmission to the engine.

NOTE

After removing the bolts, the transmission is unattached to the frame or the engine and is resting on the support jack.

7. See Figure 4. From the right side, slide the transmission toward the rear of the motorcycle (to clear the ring dowels) and lift the transmission out of the frame.

Install 6-Speed Transmission

1. Slide the 6-speed transmission with oil pan from the right side of the frame into position.
 - a. Center the the transmission rear mounts between the rear swingarm mounts.
 - b. See Figure 4. Move transmission forward to engage the 2 ring dowels in the lower flange of crankcase.
2. Align the bolt holes on the transmission to the engine by threading in and finger tightening the 4 bolts and washers.

NOTE

Use OPEN End Crowfoot (Snap-On FC018) on the upper left and upper right transmission housing to crankcase bolts.

3. See Figure 5. Tighten the transmission bolts in a cross pattern torque sequence:
 - a. 1st pass tighten to 15 ft-lbs (20.3 Nm).
 - b. 2nd pass tighten to 30-35 ft-lbs (40.7-47.5 Nm).
4. Assemble the pivot shaft assembly (pivot shaft, locknut, cup washer, rubber mount and outer spacer) and coat the pivot shaft with Loctite® Anti-Seize.

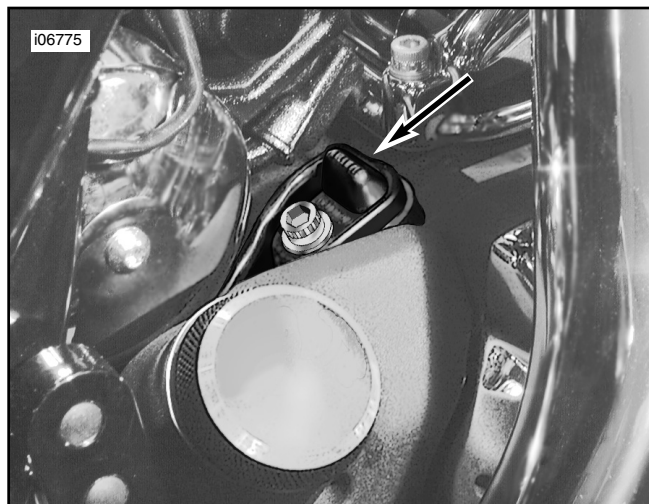

Figure 1. Vehicle Speed Sensor (behind engine oil fill plug/dipstick)

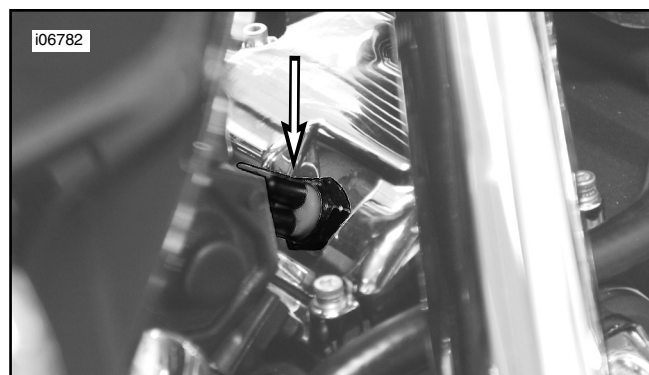

Figure 2. Neutral Indicator Switch Connector

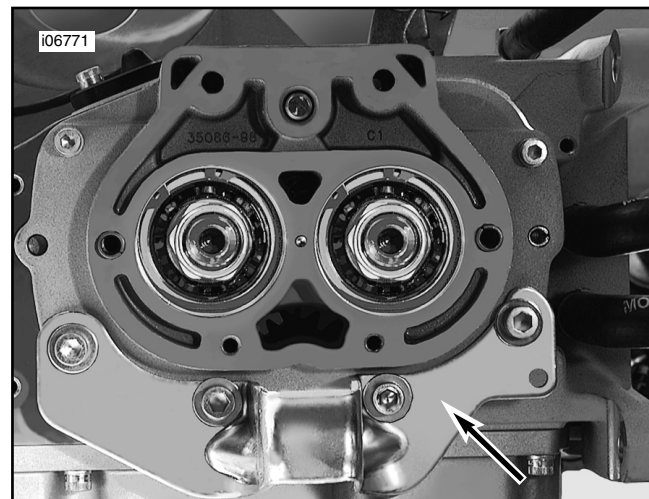

Figure 3. Exhaust Bracket on 5-Speed Side Door (side cover removed)

5. Slide rear swingarm assembly into position aligning with mounting boss of transmission case.
6. Follow the Service Manual REAR SWINGARM INSTALLATION instructions to position the rubber mounts in the rear swingarm bracket
7. Install pivot shaft and tighten locknut to 45-50 ft-lbs (61.0-67.8 Nm).
8. Install the flat washer, lockwasher and locknut to fasten shifter rod to the new 6-speed shift lever. tighten locknuts to 80-120 **in-lbs** (9.0-13.6 Nm).
9. Install the exhaust bracket and tighten bolts to 13-16 ft-lbs (18-22 Nm).
10. Install oil supply, return and breather hoses.
 - a. Fit **new** clamps onto ends of hoses.
 - b. Push and push hoses onto oil fittings
 - c. Crimp supply and return clamps with Hose Clamp Pliers (HD-41137).
 - d. Crimp breather hose clamp with Hose Clamp Pliers (HD-97087-65B).
11. Secure oil hose cover to transmission and alternately tighten screws to 84-108 **in-lbs** (10-12 Nm).
12. Install the vehicle speed sensor and tighten to 84-132 **in-lbs** (9.5-14.9 Nm).
13. Push the neutral indicator light connectors onto the neutral indicator switch.

Install Primary Chaincase

1. Follow the Service Manual PRIMARY CHAINCASE, INSTALLATION instructions to install the primary chaincase, primary chain, clutch, engine compensating sprocket, chain tensioner assembly, the starter drive mechanism and the chaincase cover.
2. Remove the inspection cover.

Install Side Cover Release Kit

Install the side cover.

For cable actuated clutch: Follow the instructions in the SE 6-Speed Cable Clutch Side Cover and Release Pushrod Kit (Part No. 38752-04).

For hydraulic clutch: Follow the instructions in the Hydraulic Clutch Side Cover and Release Pushrod Kit (Part No. 38753-04) and in the Hydraulic Clutch Kit (Part No. 45033-03 - black or 45388-03 - chrome).

Install Removed Components

1. To install the components removed to access the 5-speed transmission, follow the Service Manual instructions in the following sections:
 - a. REAR SWINGARM, INSTALLATION
 - b. REAR WHEEL, INSTALLATION
 - c. STARTER, INSTALLATION
 - d. EXHAUST SYSTEM, INSTALLATION
 - e. SADDLEBAGS, INSTALLATION

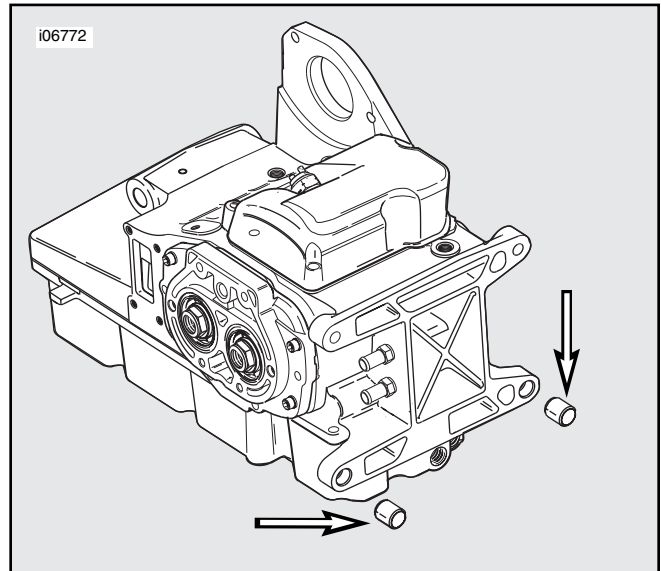

**Figure 4. Ring Dowels
(oil filler spout and side cover removed)**

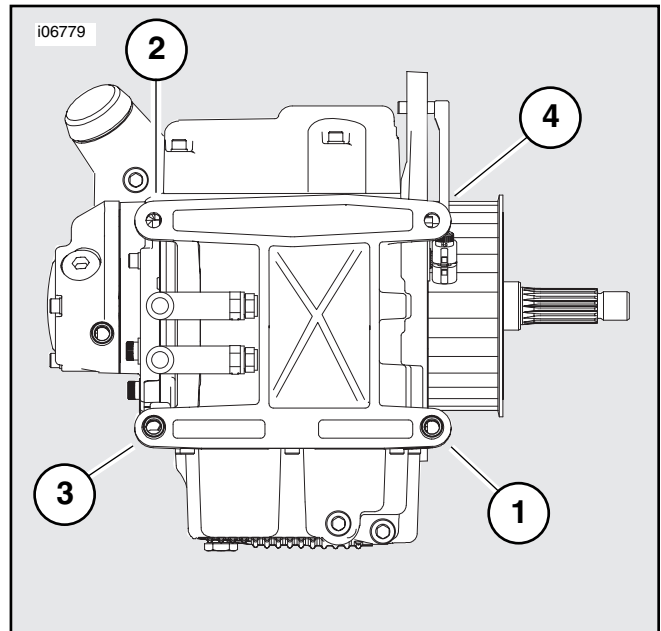

**Figure 5. Transmission to Crankcase Torque Sequence
(transmission view from front)**



Service Parts

Part No. 33136-04 & 33137-04

Date 02/05

Screamin' Eagle FLHT 6-Speed Transmission

106787

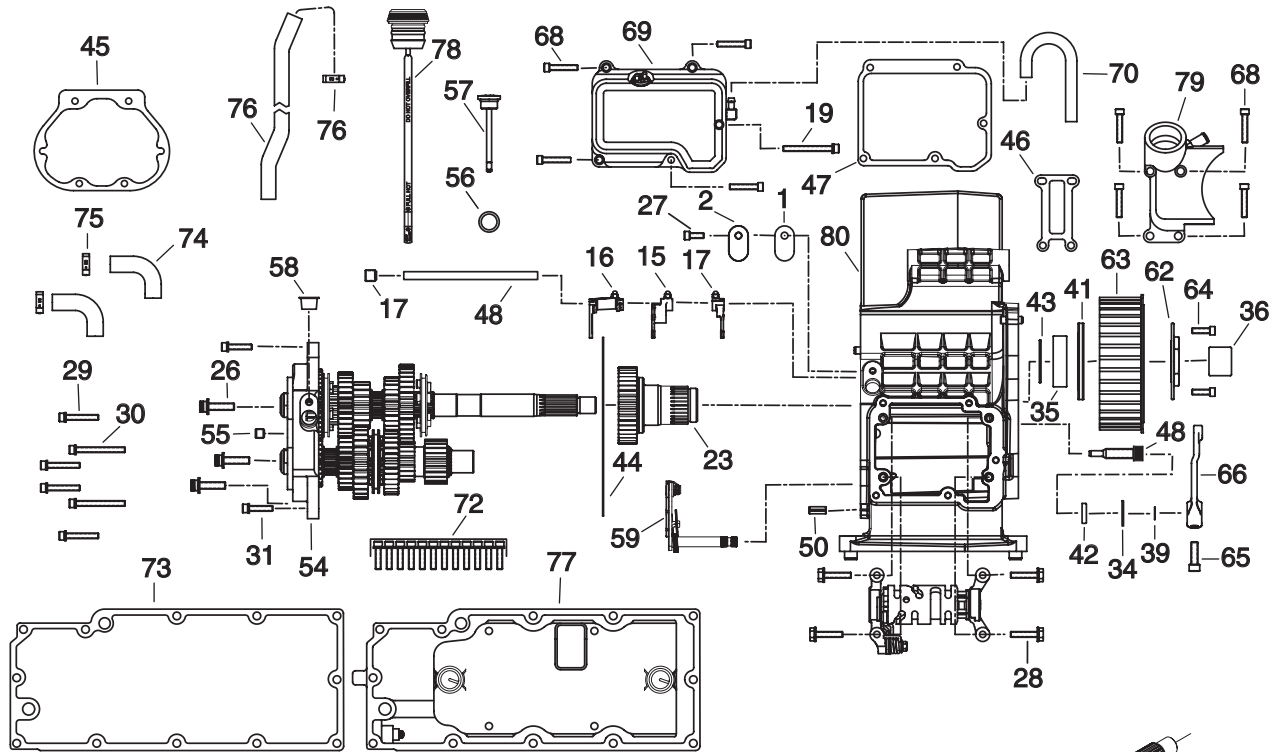

106801

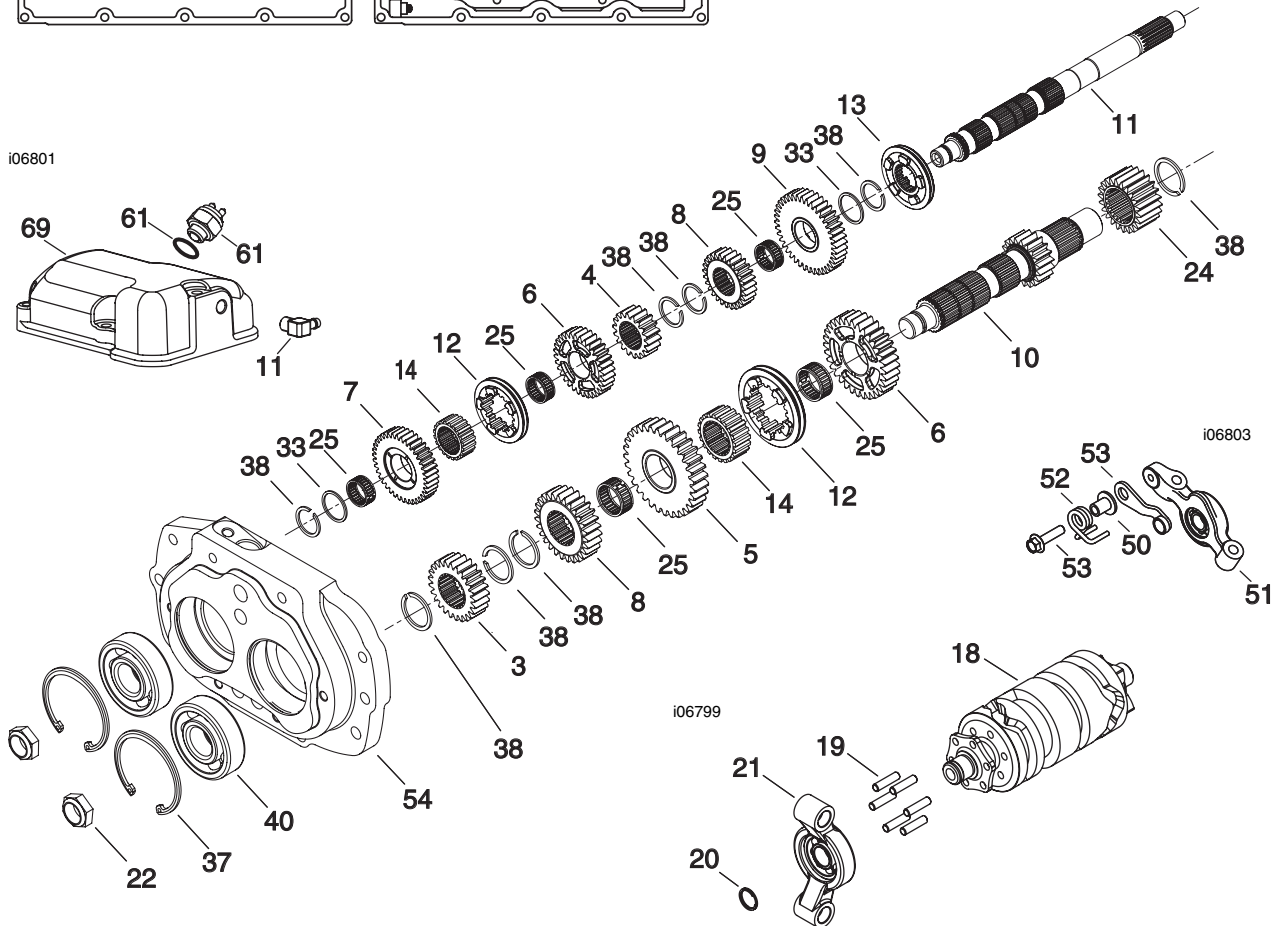

106803

106799



Service Parts

Part No. 33136-04 & 33137-04

Date 02/05

Screamin' Eagle FLHT 6-Speed Transmission

Item	Description (Qty)	Part No.	Item	Description (Qty)	Part No.
1	Gasket, sensor plate	35152-03	47	Gasket, lid	34904-86D
2	Plate, sensor	35153-03	48	Shaft, shift fork	34088-87A
3	Gear, countershaft 4th	35136-03	49	Support assembly	33304-00
4	Gear, mainshaft 1st	35134-03	50	Sleeve, detent arm spring	33375-00A
5	Gear, countershaft	35080-03	51	Detent follower assembly	33364-00A
6	Gear 3rd main/2nd counter (2)	35083-03	52	Spring, detent arm	33374-00
7	Gear, mainshaft 4th	35104-03	53	Pivot screw, detent arm	33376-00
8	Gear, 3rd counter/2nd main (2)	35135-03	54	Trapdoor, chrome no ear	35158-03
9	Gear, mainshaft 6th	35131-03	55	Plug, drain door	45830-48
10	Countershaft	35059-03	56	Dipstick, O-ring	11132
11	Mainshaft	35058-03	57	Dipstick, chrome transmission	37075-87
12	Shift ring 1_2, 3_4 (2)	35137-03	58	O-ring, speedo sensor	11289A
13	Shift ring 5_6	35138-03	59	Shifter shaft assembly	35146-03
14	Spline sleeve (2)	35140-03	60	Pin, roll	634
15	Shift fork assembly 1_2	35143-03	61	Switch, neutral indicator/O-ring	33904-00
16	Shift fork assembly 3_4	35144-03	62	Meganut	35236-03
17	Shift fork assembly 5_6	35145-03	63	Sprocket, transmission 32T	40250-94C
18	Shift drum assembly	35142-03	64	Screw, meganut (2)	4069A
19	Pin, shift drum (6)	33385-02	65	Screw, lever	856A
20	Retainer, shift drum	11242	66	Lever, shifter rod	33849-97
21	Support assembly, left cam w.bearing	33301-00A	67	Centering pin	34978-00A
22	Locknut, mainshaft & countershaft (2)	35078-79	68	Screw, top cover (8)	4740A
23	Gear, mainshaft 5th	35237-03	69	Transmission cover, chrome	34541-00
24	Gear, countershaft 5th	35238-03	70	Vent hose	42533-91A
25	Split gage bearing (5)	8876A	71	Fitting, upper cover	62375-57A
26	Screw, lower trap door (4)	3249	72	Screw, oil pan (12)	4741A
27	Screw, speedo sensor plate	3594	73	Gasket, oil pan	26077-99A
28	Screw, pillow block (4)	3909	74	Hose, oil (2)	62726-99
29	Screw, upper side cover (4)	4717A	75	Clamp (2)	10249
30	Screw, lower side cover (4)	4718A	76	Hose, crankcase to tank vent	45808-02
31	Screw, trap door, upper (2)	4814A	77	Oil pan assembly	
32	Screw, shift fork shaft	3784		black	62489-99
33	Thrust washer, main/countershaft (2)	6003		silver	62490-99
34	Washer, shifter seal	6497HW	78	Filler cap, engine oil	
35	Sprocket spacer	33344-94		black	62846-99
36	Mainshaft race	34091-85A		silver	62849-99
37	Retaining ring, door (2)	35087-99	79	Oil filler spout assembly	
38	Retaining ring, main/countershaft (8)	11067		black	62455-02
39	Retaining ring, shifter	11150		silver	62456-02
40	Bearing, trapdoor (2)	8992A	80	Trans case assembly	
41	Seal, main case	12067B		black	34839-04
42	Seal, shifter	12045		silver	34838-04
43	Quad seal	11165		Trans case (black & silver) - subcomponents	
44	Gasket, trap door	35147-03		Retaining ring	11161
45	Gasket, side cover	35148-03		Bearing, main	8996A
46	Gasket, oil spout	62432-93B		Bearing, closed end	8977

Replace Lubricants

WARNING

Be sure that no lubricant gets on tires, wheels or brakes when changing fluid. Traction can be adversely affected, which could result in loss of control of the motorcycle and death or serious injury. (00047a)

1. Follow the Service Manual PRIMARY CHAIN/LUBRICANT, PRIMARY CHAIN LUBRICANT to fill the primary chain case:
 - a. Verify that the drain plug/O-ring is installed and tighten to 36-60 **in-lbs** (4.1-6.8 Nm).
 - b. Fill with 32 ounces (946 ml) of Harley-Davidson Primary Chaincase Lubricant through inspection cover.
 - c. Follow the Service Manual to install a new gasket and cover. Tighten the cover screws to 84-108 **in-lbs** (10-12 Nm).
2. Follow the Service Manual TRANSMISSION LUBRICANT, PROCEDURE to fill the transmission with lubricant:
 - a. Verify that the transmission drain plug/O-ring are installed in the pan and tightened to 14-21 ft-lbs (19-28 Nm).
 - b. Remove the filler plug/dipstick and fill the transmission with 20-24 oz. of Harley-Davidson Semi-Synthetic Transmission Lubricant. Fill until the level is at the F (FULL) mark with the motorcycle upright.
 - c. Tighten the filler plug to 25-75 **in-lbs** (2.8-8.5 Nm).
3. Follow the Service Manual ENGINE OIL/FILTER, PROCEDURE to fill the oil tank and engine with oil:
 - a. Verify that the the engine drain plug/O-ring is installed in the pan and tightened to 14-21 ft-lbs (19-28 Nm).
 - c. Through the oil filler/dipstick spout, fill with 3 1/2 (3.3 liters) of the grade of oil specified for the lowest ambient operating temperature.
 - d. Follow Service Manual instructions to perform an engine oil level COLD CHECK and add as required.
4. **For hydraulic clutch:** If installing a Hydraulic Clutch Side Cover and Release Pushrod Kit (Part No. 38753-04) and a Hydraulic Clutch Kit (Part No. 46414-05 - chrome or 46415-05 - black), follow the instruction sheet in the kit to fill and bleed the clutch fluid lines.

Return the Motorcycle to Service

1. Follow the Service Manual REAR BELT DEFLECTION instructions to measure and adjust drive belt deflection.

WARNING

Connect positive (+) battery cable first. If positive (+) cable should contact ground with negative (-) cable connected, the resulting sparks can cause a battery explosion, which could result in death or serious injury. (00068a)

2. Connect the battery cables, positive cable first.
 - a. Tighten the bolts to 60-96 in-lbs (6.8-10.9 Nm).
 - b. Coat both terminals with Electrical Contact Lubricant (Part No. 99861-02).
 - c. Rotate the hold-down clamp to rest the rubber pad on the battery edge. Tighten to 15-20 ft-lbs (20-27 Nm).

WARNING

After installing seat, pull upward on front of seat to be sure it is in locked position. While riding, a loose seat can shift causing loss of control, which could result in death or serious injury. (00070a)

3. Follow Service Manual instructions to install the seat.
4. Turn ignition/light key to IGNITION to verify neutral indicator lamp illumination in neutral.

Test Ride Motorcycle

1. Test ride the motorcycle.
 - a. Shift into and out of each gear.
 - b. Shift into and out of neutral.
 - c. Verify operation of speedometer and vehicle speed sensor.
2. Follow Service Manual instructions to perform an engine oil level HOT CHECK.

Initial Service

Follow the Service Manual instructions to replace the transmission lubricant after 500 miles.

NOTE

After the initial service, follow the Scheduled Maintenance Table in the Service Manual and change the engine and transmission fluids at scheduled service intervals.