

FLTRXSTSE MODEL

2024 HARLEY-DAVIDSON® OWNER'S MANUAL

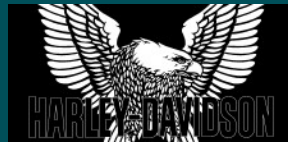

Harley-Davidson Motor Company
Service Communications
Milwaukee WI 53208 USA

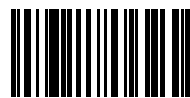

94001156

English

Printed in the USA

2024 HARLEY-DAVIDSON® OWNER'S MANUAL
FLTRXSTSE MODEL - 94001156



94001156

HARLEY-DAVIDSON

FLTRXSTSE MODEL

2024 HARLEY-DAVIDSON® OWNER'S MANUAL

⚠ WARNING: Operating, servicing and maintaining a passenger vehicle or off-road vehicle can expose you to chemicals including engine exhaust, carbon monoxide, phthalates, and lead, which are known to the State of California to cause cancer and birth defects or other reproductive harm. To minimize exposure, avoid breathing exhaust, do not idle the engine except as necessary, service your vehicle in a well-ventilated area and wear gloves or wash your hands frequently when servicing your vehicle. For more information go to www.P65Warnings.ca.gov/passenger-vehicle

⚠ WARNING: This product can expose you to chemicals including lead and lead compounds, which are known to the State of California to cause cancer and birth defects or other reproductive harm. For more information, go to www.P65Warnings.ca.gov

⚠ WARNING: Crude oil, gasoline, diesel fuel and petroleum products can expose you to chemicals, including toluene and benzene, which are known to the State of California to cause cancer and birth defects or other reproductive harm. For more information go to www.P65Warnings.ca.gov

TABLE OF CONTENTS

INTRODUCTION

Your Owner's Manual.....	1
We Care About You.....	1
United States Owners.....	1
Customer Service Assistance.....	1

SAFETY FIRST

Safety Definitions.....	3
Safe Operating Rules.....	3
Harley-Davidson Motorcycles Are for On-Road Use Only.....	4
General.....	4
Operation.....	5
Steering and Handling.....	6
Accessories and Cargo.....	6
Tires.....	9
Towing and Trailering.....	10
Fuel and Exhaust.....	10
Brakes.....	11
Battery.....	12
Hazardous Materials.....	13
Maintenance.....	13
Parts and Accessories.....	14
Anti-Lock Brake System (ABS).....	14
Rules of the Road.....	15

Noise Control System.....	15
Tampering.....	15
Safety Symbol Definitions.....	16
Labels.....	20

YOUR MOTORCYCLE

Vehicle Identification Number (VIN).....	23
General.....	23
Location.....	23
Abbreviated VIN.....	23
Models and Features.....	25
Primary Controls and Service Components.....	25

SPECIFICATIONS

Specifications.....	31
Tires.....	31
Weights and Dimensions.....	32
Capacities.....	33
Engine and Transmission.....	33
Electrical.....	34

BEFORE RIDING

Removing Motorcycle from Storage.....	35
Pre-Ride Checklist.....	35
Break-in Riding Rules.....	36
The First 500 Miles (800 Kilometers).....	36

TABLE OF CONTENTS

Filling the Fuel Tank.....	37	Front Fork.....	56
Fuel Filler Cap.....	38	SECURITY SYSTEM	
Fuel System Information.....	39	Security System.....	59
Gasoline.....	39	Components.....	59
Catalytic Converter.....	42	Options.....	59
Anti-Lock Brake System (ABS).....	42	Security System Fob.....	59
Identification.....	42	Assigning Fob.....	59
Checking Tire Pressure and Inspecting Tires.....	43	Riding with a Fob.....	60
General Information.....	43	Riding without a Fob.....	60
Tire Pressure.....	43	Personal Identification Number (PIN).....	61
Inspecting Tires.....	45	Changing the PIN.....	61
Replacing Tires.....	47	Touch Screen Entry.....	61
Adjusting Mirrors.....	48	Arming and Disarming.....	62
Operating Jiffy Stand.....	49	Arming.....	62
Location.....	49	Disarming.....	62
Jiffy Stand Switch (If equipped).....	49	Disarming with a PIN.....	62
Tire Pressure Monitoring System (TPMS).....	49	Touch Screen Entry.....	63
Suspension Adjustments.....	50	Alarm.....	64
Suspension Definitions.....	50	Warnings.....	64
Suspension Tuning.....	51	Alarm Activation.....	64
Changes in Load.....	52	Alarm Deactivation.....	64
Adjusting Rear Shock Absorbers.....	52	Siren Chirp Mode (Confirmation).....	65
Preload Adjustment.....	52	Transport Mode.....	65
Damping Adjustments.....	54	To Enter Transport Mode.....	65
Adjusting Front Shock Absorbers.....	56		

TABLE OF CONTENTS

To Exit Transport Mode.....	65	Speedometer/Odometer.....	76
Storage and Service Departments.....	65	Right-Hand Control Module.....	76
Long-Term Parking.....	65	Brakes.....	76
Service Departments.....	66	Throttle Twist Grip.....	77
Disconnecting Power.....	66	OFF/RUN/START Switch.....	77
All Models.....	66	Instruments.....	77
Troubleshooting.....	66	Speedometer.....	77
Fob.....	66	Tachometer.....	78
Siren.....	67	Fuel Gauge.....	78
OPERATION		Voltmeter.....	78
Keyless Ignition.....	69	Odometer.....	78
Ignition Mode.....	69	Indicators.....	82
Accessory Mode.....	69	Check Engine Lamp.....	82
Key Fob.....	70	Low Fuel Lamp.....	82
Retractable Key.....	70	Battery Discharge/Load Shed Indicator.....	82
Security System.....	70	Fault Alert Indicator.....	83
Replacing the Battery.....	71	Turn Signal Indicators.....	83
Fork Lock.....	73	Headlamp High Beam Indicator.....	83
Locking Fork.....	73	Cruise Control Indicator.....	83
Unlocking Fork.....	73	Gear Indicator.....	83
General: Controls and Indicators.....	74	ABS Lamp.....	84
Controls, Instruments and Switches.....	74	Oil Pressure Indicator.....	85
Clutch Hand Lever.....	74	Low Tire Pressure/TPMS Fault Lamp.....	85
Gear Shift Lever.....	75	Traction Control/Alert Indicator.....	86
Left-Hand Control Module.....	75	Ride Mode Indicator.....	86
		Vehicle Hold Control Indicator.....	86

TABLE OF CONTENTS

Mobile Device - State of Charge.....	87	Next.....	94
Mobile Device - Bluetooth Active.....	87	Volume Down.....	94
Mobile Device - Signal.....	87	Previous.....	94
Mobile Device - Wi-Fi active.....	87	Play/Pause.....	94
Mobile Device - headset connection.....	87	Push-to-Talk.....	95
Fan ON/Auto Indicator.....	87	Start.....	95
Brake Fluid Service Indicator.....	87	Voice Recognition.....	95
Coolant Temperature Indicator.....	87	Mode.....	95
Left Hand Control Switches.....	88	Infotainment Control Unit (IFCU).....	98
Trip Switch.....	88	Controls.....	98
Headlamp.....	88	Main Menu.....	99
Cruise Control Switch Assembly.....	88	Status Bar Notifications.....	102
Left Turn Signal.....	89	Widgets.....	102
Horn.....	89	IFCU Layout.....	103
Traction Control Switch.....	89	Basic Audio Operation.....	105
Navigate UP/DOWN/RIGHT/LEFT Switches.....	89	Alert messages.....	105
OK/Enter Button.....	90	Side Stand Down Warning Message.....	105
Back.....	90	Fuel Range Alerts.....	106
Main Menu/Bike Function.....	90	Bike Tipped Warning.....	107
Right Hand Control Switches.....	93	Fob Missing Alert.....	107
Hazard Warning 4-Way Flasher.....	93	Tire Pressure Alert.....	108
OFF.....	94	Low Temperature Alert.....	108
RUN.....	94	Electronic Labels.....	109
Right Turn Signal.....	94	Ride Modes.....	109
Volume Up.....	94	Ride Modes.....	109

TABLE OF CONTENTS

Ride Mode Fault.....	111	Cornering Rider Safety Enhancements.....	123
Cruise Control.....	111	Front Brake Lever.....	123
Turn Cruise On.....	111	Rear Brake Pedal.....	123
Set Cruise Speed.....	112	ABS and Cornering Enhanced ABS (C-ABS) Functions.....	123
Increase/Decrease Cruise.....	112	How ABS Works.....	124
Disengage Cruise.....	112	Cornering Enhanced Electronic Linked Braking (C-ELB).....	124
Resume Cruise.....	112	How To Use ABS.....	124
Turn Cruise Off.....	112	Vehicle Hold Control (VHC).....	124
Electronic Throttle Control (ETC).....	113	Tire Pressure Monitoring System (TPMS).....	125
ETC Limited Performance Mode.....	114	ABS: Tires and Wheels.....	125
ETC Power Management Mode.....	114	Traction Control.....	127
ETC Forced Idle Mode.....	114	Traction Control System.....	127
ETC Forced Shut Down Mode.....	114	How Traction Control Works.....	127
Accessory Connector.....	114	How To Use Traction Control.....	128
Headset Connection.....	115	Shifting Gears.....	129
Media Compartment.....	116	Stopped, Engine Off.....	129
Compartment.....	116	Starting from a Stop.....	129
Devices.....	117	Upshift (Acceleration).....	130
Starting the Engine.....	118	Downshift (Deceleration).....	130
General.....	118	Fairing Vent.....	132
Starting.....	119	Adjustable Air Deflectors.....	132
Starting after Tipover.....	120	SADDLEBAGS.....	133
Engine Idle Temperature Management System (EITMS).....	121	Opening.....	133
Operation.....	121	Closing.....	133
Enabling / Disabling EITMS.....	122		
Stopping the Engine.....	122		

TABLE OF CONTENTS

Remove.....	134	Making a Call.....	152
Install.....	134	Receiving a Call.....	154
Luggage.....	136	Messages.....	154
INFOTAINMENT CONTROL UNIT (IFCU) OPERATION		Projection Mode.....	154
System Settings.....	139	Bike Functions.....	155
Settings Menu.....	139	Bike Functions.....	155
Device Manager.....	139	Software Updates.....	156
Sound.....	140	Help.....	158
Display.....	142	AFTER RIDING	
System.....	142	Genuine Motor Parts and Accessories.....	161
Ride Mode.....	143	Online Catalog.....	161
Tuner.....	146	Shop for Your Bike.....	161
Phone.....	146	Cleaning and General Care.....	161
.....	146	Cleaning Wheels and Tires.....	162
Audio.....	146	Recommended Cleaning Products.....	162
Selecting Media Source.....	146	Washing the Motorcycle.....	166
Tune/Seek.....	147	Preparation.....	166
Finding a Media File.....	147	Cleaning Wheels and Tires.....	167
Favorites.....	148	Washing the Motorcycle.....	167
Voice Recognition.....	148	Drying the Motorcycle.....	167
Navigation.....	149	Polishing and Sealing.....	168
Navigation (If Equipped).....	149	Windshield Care.....	168
Phone.....	152	Leather and Vinyl Care.....	169
		Audio System Care.....	169

TABLE OF CONTENTS

Screen.....	170	Add Coolant.....	196
Cleaning the Radio.....	170	Clean Radiator.....	197
Speaker Care.....	170	Checking Coolant Freeze Point.....	198
Fairing Splitstream Vent Care.....	170	Check Drive Belt Deflection.....	198
Exhaust Care.....	170	Miscellaneous Lubrication.....	201
Wheel Care.....	171	Mechanical Clutch.....	201
Storing Motorcycle.....	172	Hydraulic Lifters.....	202
MAINTENANCE AND LUBRICATION		Checking for Exhaust Leaks.....	202
Break-in Maintenance.....	175	Maintaining Front Fork.....	202
Disposal and Recycling.....	175	Adjusting Steering Head Bearings.....	203
Engine Lubrication: Synthetic Oil.....	175	Shock Absorbers.....	203
Check Engine Oil Level.....	177	Inspecting Air Filter.....	203
Oil Level Cold Check.....	177	Removal.....	203
Oil Level Hot Check.....	177	Cleaning Filter Element.....	203
Change Oil and Oil Filter.....	179	Installation.....	204
Low Temperature Lubrication.....	182	Inspecting Breather Hose.....	205
Check Transmission Lubricant.....	182	Replacing Spark Plugs.....	205
Change Transmission Lubricant.....	184	SERVICE PROCEDURES	
Primary Chaincase Lubrication: Synthetic Oil.....	186	Side Covers.....	207
Change Primary Chaincase Lubricant.....	186	Battery Tender Connector.....	207
BRAKES.....	190	Battery Maintenance.....	209
Brake Fluid.....	191	Battery Safety.....	209
Brake Pads.....	193	Absorbed Glass Mat (AGM) Battery Charging Information.....	210
Cooling System.....	195	Cleaning and Inspecting.....	210
Checking Coolant Level.....	196		

TABLE OF CONTENTS

Charging and Storing the Battery.....	211	Starts Hard.....	225
Battery Replacement.....	212	Starts but Runs Irregularly or Misses.....	226
Disconnection and Removal.....	212	A Spark Plug Fouls Repeatedly.....	226
Installation and Connection.....	213	Pre-Ignition or Detonation (Knocks or Pings).....	226
Fuses.....	217	Overheats.....	226
Main Fuse.....	217	Excessive Vibration.....	226
System Fuses.....	217	Engine Oil Not Circulating (Oil Pressure Lamp Lit).....	226
Check Headlamp Alignment.....	219	Electrical System.....	227
Headlamp Alignment.....	220	Alternator Does Not Charge.....	227
Adjust Headlamp.....	220	Alternator Charge Rate is Below Normal.....	227
Headlamp Replacement.....	221	Transmission.....	227
Tail Lamp Bulb Replacement: LED.....	221	Transmission Shifts Hard.....	227
Turn Signal Bulb Replacement: LED.....	222	Transmission Jumps Out of Gear.....	227
Seat.....	222	Clutch Slips.....	227
Passenger Seat Cowl Removal.....	222	Clutch Drags or Does Not Release.....	227
Rider Seat Removal.....	222	Clutch Chatters.....	227
Rider Seat Installation.....	222	Brakes.....	227
Passenger Seat Cowl Installation.....	222	ABS System Behavior.....	227
		Brakes Do Not Hold Normally.....	228
		Handling.....	228
TROUBLESHOOTING		WARRANTIES AND RESPONSIBILITIES	
Troubleshooting: General.....	225	Maintenance Responsibilities.....	229
Engine.....	225	Finding an Authorized Dealer.....	229
Starter Does Not Operate or Does Not Turn Engine Over.....	225	Reporting Safety Defects in the United States.....	229
Engine Turns Over but Does Not Start.....	225		

TABLE OF CONTENTS

NHTSA Statement.....	230
Reporting Safety Concerns in Canada.....	230
Required Documentation for Imported Motorcycles.....	230
Owner Contact Information.....	231
Questions and Concerns.....	231

LIMITED MOTORCYCLE WARRANTY

2024 HARLEY-DAVIDSON LIMITED MOTORCYCLE WARRANTY.....	233
24 Months/Unlimited Miles.....	233
Disclaimers & Limitations.....	233
Warranty Duration.....	234
Owner's Obligations.....	235
Exclusions.....	235
On-Road/Off-Road Vehicles.....	236
Other Limitations.....	236
Important: Read Carefully.....	238
Environmental Factors.....	239
USA Owners 49 State Limited Emissions Warranty....	240
Items Covered by this Emission Warranty.....	242
Recommendations for Required Maintenance.....	243
California and Select International Markets Evaporative Emission Controls.....	243
California Emissions Control Warranty Statement	243

Manufacturer's Warranty Coverage.....	244
Owner's Warranty Responsibilities.....	244
Additional Warranty Terms.....	245
What Is Covered by this Emission Warranty.....	246
What Is Not Covered by this Emission Warranty.....	247
EPA Regulations.....	247
Noise Control System Limited Warranty.....	248
Recommendations for Required Maintenance.....	250
Limited Motorcycle Warranty Australia/ New Zealand Only.....	250

SERVICE INTERVALS AND RECORDS

Service Records.....	253
Regular Service Intervals.....	253
Service Intervals.....	253
Service Actions.....	253
Maintenance Records.....	253

APPENDIX

Acronyms and Abbreviations.....	259
H-D U.S.A., LLC Trademark Information.....	261
Product Registered Marks.....	261
Patents.....	261
Copyright.....	261

NOTES



YOUR OWNER'S MANUAL

We Care About You

Welcome to the Harley-Davidson Motorcycling Family! When enjoying your Harley-Davidson motorcycle, be sure to ride safely, respectfully and within the limits of the law and your abilities. Always wear a helmet, proper eyewear and protective clothing, and insist your passenger does too. Never ride while under the influence of alcohol or drugs. Know your Harley and read and understand your owner's manual from cover to cover.

This manual has been prepared to acquaint you with the operation, care and maintenance of your motorcycle and to provide you with important safety information. Follow these instructions carefully for maximum motorcycle performance and for your personal motorcycling safety and pleasure. Your Owner's Manual contains instructions for operation and minor maintenance. Major repairs are covered in the Harley-Davidson Service Manual. Such major repairs require the attention of a skilled technician and the use of special tools and equipment. Your Harley-Davidson dealer has the facilities, experience and Genuine Harley-Davidson parts necessary to properly render this valuable service. We recommend that any emission system maintenance be performed by an authorized Harley-Davidson dealer.

Attend a rider safety course. To enroll in a Harley-Davidson Riding Academy course, call 1-414-343-4056 (U.S.) or visit www.harley-davidson.com/learntoride. In the United States, for information about Motorcycle Safety Foundation rider courses, call 1-800-446-9227 or visit www.msf-usa.org.

United States Owners

Your Harley-Davidson motorcycle conforms to all applicable U.S. Federal Motor Vehicle Safety Standards and U.S. Environmental Protection Agency regulations effective on the date of manufacture. Protect your privilege to ride by joining the American Motorcyclist Association. Visit www.americanmotorcyclist.com for more information.

Harley-Davidson reserves the right to change specifications, equipment or designs at any time without notice and without incurring obligation.

CUSTOMER SERVICE ASSISTANCE

Most sales or service issues are resolved at the dealership.

1. Discuss your problem with the appropriate personnel at the dealership in the Sales, Service or Parts area. If that proves unsuccessful, speak to the owner of the dealership or the general manager.

2. If you cannot resolve the issue with the dealership, contact the Harley-Davidson Customer Support Center. Harley-Davidson Motor Company Attention: Harley-Davidson Customer Support Center P.O. Box 653 Milwaukee, Wisconsin 53201 1-800-258-2464 (U.S. only) 1-414-343-4056

For customers outside the US, contact your local Harley-Davidson market office, call 1-414-343-4056 or visit harley-davidson.com.

Table 2. Vehicle and Personal Data

PERSONAL INFORMATION	DEALER INFORMATION
Date of Purchase:	
Name:	Name:
Address:	Address:
Address:	Address:
Vehicle Identification Number:	Sales Contact:
Key Number:	Service Contact:

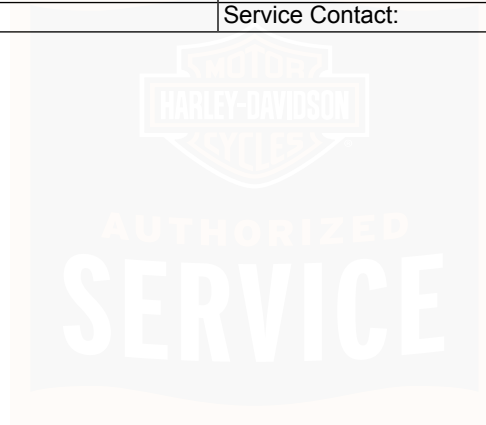

SAFETY DEFINITIONS

Statements in this manual preceded by the following words are of special significance:

▲ WARNING

WARNING indicates a potentially hazardous situation which, if not avoided, could result in death or serious injury. (00119a)

▲ CAUTION

CAUTION indicates a potentially hazardous situation which, if not avoided, may result in minor or moderate injury. (00139a)

NOTICE

NOTICE indicates a potentially hazardous situation which, if not avoided, may result in property damage. (00140b)

NOTE

Refers to important information and is placed in italic type. It is recommended that you take special notice of these items.

SAFE OPERATING RULES

▲ WARNING

Motorcycles are different from other vehicles. They operate, steer, handle and brake differently. Unskilled or improper use could result in loss of control, death or serious injury.

- Take a rider training course.
- Read owner's manual before riding, adding accessories or servicing.
- Wear a helmet, eye protection and protective clothing.
- Never tow a trailer.

(00556d)

⚠ WARNING

Operating a motorcycle requires physical stamina, sensory abilities, motor coordination, and mental alertness. It is the responsibility of the operator to perform a self-assessment to determine their ability to safely operate a motorcycle. Avoid operating a motorcycle:

- If you have physical, medical, or mental limitations.
- If you are under the influence of alcohol, drugs, or medications.
- If you experience drowsiness, exhaustion, confusion, inability to concentrate, impaired reaction time, numbness or loss of sensation.

Failure to avoid these, or other conditions that impair your judgment or ability to operate a motorcycle can lead to an accident which could result in death or serious injury. (16804a)

Harley-Davidson Motorcycles Are for On-Road Use Only

This motorcycle is not equipped with a spark arrester. This motorcycle is designed to be used only on the road. Operation or off-road usage in some areas may be illegal. Obey local laws and regulations.

General

⚠ WARNING

Consult a Harley-Davidson dealer regarding any questions or problems that occur in the operation of your motorcycle. Failure to do so can aggravate an initial problem, cause costly repairs, cause an accident and could result in death or serious injury. (00020a)

- Make sure all equipment required by federal, state and local law is installed and in good operating condition.
- Know and respect the rules of the road. Read the safety information that is provided by your state or regional traffic authority.
- In the United States, read the RIDING TIPS booklet that is provided with this owner's manual. Read the MOTORCYCLE HANDBOOK which is made available by your state or regional traffic authority.
- Protect your motorcycle against theft. Lock the front fork. Remove the key when parking your motorcycle.

⚠ WARNING

Do not add sidecar to this motorcycle. Operating motorcycle with sidecar can cause loss of vehicle control, which could result in death or serious injury. (00590d)

Operation

Before operating your new motorcycle, it is your responsibility to read and follow the operating and maintenance instructions in this manual and follow these rules for your personal safety.

- Before starting the engine, review the BEFORE RIDING > PRE-RIDE CHECKLIST (Page 35).

⚠ WARNING

Striking an object, such as a curb or pothole can cause internal tire damage. If an object is struck, have the tire inspected immediately inside and out by a Harley-Davidson dealer. A damaged tire can fail while riding and adversely affect stability and handling, which could result in death or serious injury. (00058b)

⚠ WARNING

Travel at speeds appropriate for road and conditions and never travel faster than posted speed limit. Excessive speed can cause loss of vehicle control, which could result in death or serious injury. (00008a)

- Do not exceed the legal speed limit or drive too fast for existing conditions. Always reduce speed when poor driving conditions exist. High speed increases the influence of any other condition affecting stability and increases the possibility of loss of control.

- Pay strict attention to road surfaces and wind conditions and keep both hands on the handlebar grips at all times when riding the motorcycle. Any two wheeled vehicle may be subject to upsetting forces such as wind blasts from passing trucks, holes in the pavement, rough road surfaces, rider control error, etc. These forces may influence the handling characteristics of your motorcycle. If this happens, reduce speed and guide the motorcycle with a relaxed grip to a controlled condition. Do not brake abruptly or force the handlebar. This may aggravate an unstable condition.
- New riders should gain experience under various conditions while riding at moderate speeds.
- Operate your motorcycle defensively. In an accident, a motorcycle does not afford the same protection as an automobile.
- It is the rider's responsibility to instruct passengers on proper riding procedures.
- Do not allow other individuals to operate the motorcycle unless they are experienced, licensed riders and are thoroughly familiar with the operation of the motorcycle.

⚠ WARNING

If Equipped: Front and/or rear guards are not intended to provide protection from bodily injury in a collision with another vehicle or any other object. (00022d)

Steering and Handling

⚠ WARNING

Do not operate vehicle with forks locked. Locking the forks restricts the vehicle's turning ability, which could result in death or serious injury. (00035a)

⚠ WARNING

Regularly inspect shock absorbers and front forks. Replace leaking, damaged or worn parts that can adversely affect stability and handling, which could result in death or serious injury. (00012a)

⚠ WARNING

Do not operate motorcycle with loose, worn or damaged steering or suspension systems. Contact a Harley-Davidson dealer for repairs. Loose, worn or damaged steering or suspension components can adversely affect stability and handling, which could result in death or serious injury. (00011a)

⚠ WARNING

Do not open storage compartments while riding. Distractions while riding can lead to loss of control, which could result in death or serious injury. (00082a)

⚠ WARNING

When riding on wet roads, brake efficiency and traction are greatly reduced. Failure to use care when braking, accelerating or turning on wet roads can cause loss of control, which could result in death or serious injury. (00041a)

Accessories and Cargo

⚠ WARNING

Do not exceed the motorcycle's Gross Vehicle Weight Rating (GVWR) or Gross Axle Weight Rating (GAWR). Exceeding these weight ratings can lead to component failure and adversely affect stability, handling and performance, which could result in death or serious injury. (00016f)

- GVWR is the sum of the weight of the motorcycle, accessories and the maximum weight of the rider, passenger and cargo that can be safely carried.
- The GVWR is shown on the information label, located on the frame steering head or the frame downtube.
- GAWR is the maximum amount of weight that can be safely carried on each end of the motorcycle.

- For GVWR and GAWR, front and rear, see SPECIFICATIONS > SPECIFICATIONS (Page 31).



⚠ WARNING



Improper loading of cargo or installation of accessories can affect motorcycle stability and handling, which could result in death or serious injury.

- Keep cargo weight concentrated close to the motorcycle and as low as possible to minimize the change in the motorcycle's center of gravity.
- Distribute weight evenly on both sides of the vehicle.
- Do not load bulky items too far behind the rider or add weight to the handlebars or front forks.
- Do not exceed maximum load capacity stated on the label for bags, luggage, and racks, if equipped. Combined load of luggage rack and Tour-Pak must not exceed load capacity on the label within the Tour-Pak.
- Do not exceed the maximum load capacity stated within the media compartment, when indicated and if equipped.
- Check that cargo is secure. The cargo cannot shift while riding. Periodically recheck load.
- Close and lock luggage before riding or leaving the vehicle unattended.
- Accessories that change the operator's riding position may increase reaction time and affect handling of the motorcycle.

- Items with large surface areas, such as fairings, windshields, backrests and luggage racks (if equipped) can adversely affect stability and handling.

(14717c)

Tires

⚠ WARNING

Be sure tires are properly inflated, balanced, undamaged, and have adequate tread. Inspect your tires regularly and see a Harley-Davidson dealer for replacements. Riding with excessively worn, unbalanced, improperly inflated, overloaded or damaged tires can lead to tire failure and adversely affect stability and handling, which could result in death or serious injury. (00014b)

⚠ WARNING

Replace punctured or damaged tires. In some cases, small punctures in the tread area may be repaired from within the removed tire by a Harley-Davidson dealer. Speed should NOT exceed 50 mph (80 km/h) for the first 24 hours after repair, and the repaired tire should NEVER be used over 80 mph (129 km/h). Failure to follow this warning could lead to tire failure and result in death or serious injury. (00015b)

⚠ WARNING

Do not use liquid tire balancers or sealants in aluminum wheels. Using liquid tire balancers or sealants can cause rapid corrosion of the rim surface, which could cause tire deflation. Tire deflation can cause loss of vehicle control, which could result in death or serious injury. (00631b)

- Tire pressure will vary with changes in ambient and tire temperature. Always maintain proper tire pressure as specified in OWNER MANUAL > SPECIFICATIONS (Page 31). Do not load tires beyond the GAWR specified in OWNER MANUAL > SPECIFICATIONS (Page 31). Under-inflated, over-inflated or overloaded tires can fail.

Towing and Trailing

⚠ WARNING

Do not pull a trailer with a motorcycle. Pulling a trailer can cause tire overload, damage and failure, reduced braking performance, and adversely affect stability and handling, which could result in death or serious injury. (00018c)

⚠ WARNING

Do not tow a disabled motorcycle. Towing can adversely affect stability and handling, which could result in death or serious injury. (00017a)

- Never tow a trailer.

Fuel and Exhaust

⚠ WARNING

Stop the engine when refueling or servicing the fuel system. Do not smoke or allow open flame or sparks near gasoline. Gasoline is extremely flammable and highly explosive, which could result in death or serious injury. (00002a)

⚠ WARNING

Avoid spills. Slowly open fuel filler cap. Do not fill above bottom of filler neck insert, leaving air space for fuel expansion. Secure filler cap after refueling. Gasoline is extremely flammable and highly explosive, which could result in death or serious injury. (00028b)

- Refuel in a well-ventilated area with the engine off.
- Remove the fuel filler cap slowly.
- Do not fill fuel tank above the bottom of the filler neck insert. Leave air space to allow for fuel expansion.
- If fuel tank was completely drained, add at least 1 gal (3.79 L) of gas.

⚠ WARNING

Avoid contact with exhaust system and wear protective clothing that completely covers legs while riding. Exhaust pipes and mufflers get very hot when engine is running and remain too hot to touch, even after engine is turned off. Failure to wear protective clothing could result in burns or other serious injury. (00009a)

⚠ WARNING

Do not run motorcycle in a closed garage or confined area. Inhaling motorcycle exhaust, which contains poisonous carbon monoxide gas, could result in death or serious injury. (00005a)

⚠ WARNING

Engine exhaust from this product contains chemicals known to the State of California to cause cancer, and birth defects or other reproductive harm. (00004f)

Brakes

⚠ WARNING

Brakes are a critical safety component. Contact a Harley-Davidson dealer for brake repair or replacement. Improperly serviced brakes can adversely affect brake performance, which could result in death or serious injury. (00054a)

⚠ WARNING

Apply front and rear brakes evenly. Favoring one brake accelerates wear and reduces braking efficiency. Operation with excessively worn brakes can lead to brake failure, which could result in death or serious injury. (00135a)

⚠ WARNING

DOT 4 brake fluid absorbs moisture from the atmosphere over time, changing the properties of the fluid. Check brake fluid moisture content at every service interval or annually (whichever comes first). Flush and replace the brake fluid every two years, or sooner if moisture content is 3% or greater. Failure to flush and replace fluid can adversely affect braking, which could result in death or serious injury. (06304b)

⚠ WARNING

Contact with DOT 4 brake fluid can have serious health effects. Failure to wear proper skin and eye protection could result in death or serious injury.

- If inhaled: Keep calm, remove to fresh air, seek medical attention.
- If on skin: Remove contaminated clothing. Rinse skin immediately with plenty of water for 15-20 minutes. If irritation develops, seek medical attention.
- If in eyes: Wash affected eyes for at least 15 minutes under running water with eye lids held open. If irritation develops, seek medical attention.
- If swallowed: Rinse mouth and then drink plenty of water. Do not induce vomiting. Contact Poison Control. Immediate medical attention required.
- See Safety Data Sheet (SDS) for more details available at sds.harley-davidson.com

(00240e)

To ensure the brake system is performing to design, check the moisture content of the brake fluid at every service interval or at least annually using a DOT 4 brake fluid moisture tester (part number HD-48497-A or equivalent) following the instructions included with the tool. Flush DOT 4 fluid every 2

years or sooner if the brake system fluid test shows moisture content is 3% or greater.

Harley-Davidson recommends using Harley-Davidson Platinum Label DOT 4 Brake Fluid because of its superior moisture and corrosion inhibiting properties.

Battery

⚠ WARNING

Batteries, battery posts, terminals and related accessories contain lead and lead compounds, and other chemicals known to the State of California to cause cancer, and birth defects or other reproductive harm. Wash hands after handling. (00019e)

⚠ WARNING

Batteries contain sulfuric acid, which could cause severe burns to eyes and skin. Wear a protective face shield, rubberized gloves and protective clothing when working with batteries. **KEEP BATTERIES AWAY FROM CHILDREN.** (00063a)

NOTICE

It is possible to overload the vehicle's charging system by adding too many electrical accessories. If the combined electrical accessories operating at any one time consume more electrical current than the vehicle's charging system can produce, the electrical consumption can discharge the battery and cause damage to the vehicle's electrical system. (00211d)

⚠ WARNING



CONTAINS BUTTON OR COIN CELL BATTERY. KEEP OUT OF REACH OF CHILDREN.

Ingestion can result in death or serious injury. Choking, chemical burns and perforation of soft tissue may result. Severe burns can occur within 2 hours of ingestion or placement in any part of the body. Seek medical attention immediately. (13105b)

Hazardous Materials

⚠ CAUTION

Prolonged or repeated contact with used motor oil may be harmful to skin and could cause skin cancer. Promptly wash affected areas with soap and water. (00358b)

Maintenance

⚠ WARNING

Perform the service and maintenance operations as indicated in the regular service interval table. Lack of regular maintenance at the recommended intervals can affect the safe operation of your motorcycle, which could result in death or serious injury. (00010a)

NOTICE

When lifting a motorcycle using a jack, be sure jack contacts both lower frame tubes where down tubes and lower frame tubes converge. Never lift by jacking on cross-members, oil pan, mounting brackets, components or housings. Failure to comply can cause serious damage resulting in the need to perform major repair work. (00586d)

- A new motorcycle must be operated according to the special break-in procedure. See BEFORE RIDING > BREAK-IN RIDING RULES (Page 36).
- Proper care and maintenance, including tire pressure, tire condition, tread depth and proper adjustment to steering head bearings are important to stability and safe operation of the motorcycle. See SERVICE INTERVALS AND RECORDS > SERVICE RECORDS (Page 253).

Parts and Accessories

⚠ WARNING

Harley-Davidson parts and accessories are designed for Harley-Davidson motorcycles. Using non-Harley-Davidson parts or accessories can adversely affect performance, stability or handling, which could result in death or serious injury. (00001b)

⚠ WARNING

Use Harley-Davidson replacement fasteners. Aftermarket fasteners can adversely affect performance, which could result in death or serious injury. (00013a)

- See your Harley-Davidson service manual for proper torque values.
- Aftermarket fasteners may not have the specific property requirements to perform properly.

⚠ WARNING

See ACCESSORIES AND CARGO section within the SAFETY FIRST section in your owner's manual. Improper cargo loading or accessory installation can cause component failure and adversely affect stability, handling and performance, which could result in death or serious injury. (00021c)

- Harley-Davidson Motor Company cannot test and make specific recommendations concerning every accessory or combination of accessories sold. Therefore, the rider must be responsible for safe operation of the motorcycle when installing accessories or carrying additional weight.
- Additional electrical equipment may overload the electrical system possibly resulting in electrical system and/or component failure.

ANTI-LOCK BRAKE SYSTEM (ABS)

⚠ WARNING

If ABS lamp continues flashing at speeds greater than 3 mph (5 km/h) or remains on continuously, the ABS is not operating. The standard brake system is operational, but wheel lock up can occur. Contact a Harley-Davidson Dealer to have ABS repaired. A locked wheel will skid and can cause loss of vehicle control, which could result in death or serious injury. (00361b)

To operate motorcycles equipped with an anti-lock brake system, see OPERATION > CORNERING RIDER SAFETY ENHANCEMENTS (Page 123).

RULES OF THE ROAD

- Always use your turn signals and exercise caution when passing other vehicles going in the same direction. Never pass going in the same direction at street intersections, on curves or when going up or down a hill.
- At street intersections, give the right-of-way. Do not presume you have the right-of-way, as the other driver may not know that it is your turn.
- Always signal when preparing to stop, turn or pass.
- Promptly obey all traffic signs, including those signs used for the control of traffic at intersections. Always obey traffic signs near schools and at railroad crossings.
- When intending to turn, signal at least 100 ft (30.5 m) before reaching the turning point. If turning across an intersection, move over to the centerline of the street (unless local rules require otherwise). Slow down when entering the intersection and turn carefully.
- Never anticipate a traffic light. When a change is indicated from GO to STOP (or STOP to GO), slow down and wait for the light to change. Never run through a yellow or red traffic light.

- While turning, watch for pedestrians, animals, as well as vehicles.
- Do not leave the curb or parking area without signaling. Make sure that your way is clear to enter moving traffic. A moving line of traffic always has the right-of-way.
- Make sure that your license plate is installed in the position specified by law. Make sure that your license plate is always clearly visible. Keep the license plate clean.
- Ride at a safe speed that is consistent with the type of highway you are on. Pay strict attention to whether the road is dry, oily, icy or wet.
- Watch for debris such as leaves or loose gravel.
- Weather and traffic conditions on the highway dictate adjusting your speed and driving habits accordingly.

NOISE CONTROL SYSTEM

Tampering

Removal or replacement of any noise control system component may be prohibited by law. This prohibition includes modifications made prior to vehicle sale or delivery to the ultimate purchaser. Use of a vehicle on which noise control system components have been removed or rendered inoperative may also be prohibited by law.

SAFETY SYMBOL DEFINITIONS







These are some of the symbols that you may see on your motorcycle and may accompany safety words, see SAFETY FIRST > SAFETY DEFINITIONS (Page 3). The symbols indicate potential safety hazards and avoidance actions to prevent a hazardous situation. The symbols may be present in manuals, instructions, on the motorcycle and/or Parts & Accessory product labels. Refer to SAFETY FIRST > SAFE OPERATING RULES (Page 3), the appropriate section in

this manual and/or Parts & Accessory instructions for additional safety information.

- Yellow triangle: Safety symbol alerting to a hazard. Table 3
- Red circle with line: Prohibition symbol to avoid a situation which may lead to a hazard, personal injury and/or property damage. Table 4
- Blue circle: Mandatory action to avoid a hazard resulting in personal injury and/or property damage. Table 5



Table 3. General Warning Symbols

SYMBOL	SYMBOL DEFINITION	SYMBOL	SYMBOL DEFINITION
	General Warning indicating a hazard.		Explosive material hazard.
	Crash hazard.		Corrosive chemical burn hazard.
	Electric shock hazard.		Hot surface hazard.
	Battery charging hazard.		

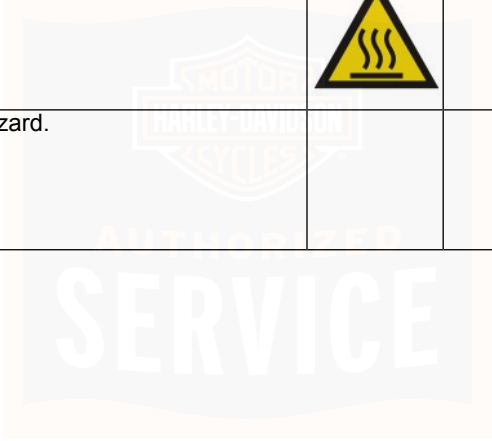

Table 4. General Prohibition Symbols









SYMBOL	SYMBOL DEFINITION	SYMBOL	SYMBOL DEFINITION
	General prohibition sign to signify a prohibited action.		Do not expose to fire.
	Do not service without proper training or tools. Qualified technician only. Not user serviceable. No user replaceable parts. Refer service to qualified technician.		Do not perform action above indicated temperature.
	Do not touch.		Never tow a trailer.
	Keep away from open flame. Avoid smoking, flames, or sparks.		Do not use an extension cord.



Table 5. General Mandatory Action Symbols













SYMBOL	SYMBOL DEFINITION	SYMBOL	SYMBOL DEFINITION
	General mandatory action.		Wear proper protective riding apparel.
	Keep out of reach of children.		Wear proper hand protection.
	Refer to appropriate manual or instructions.		Wear proper Personal Protective Equipment (PPE).
	Take a rider training course.		Wear proper eye protection.
	Wear a helmet and eye protection.		

Table 6. General Information Symbols

SYMBOL	SYMBOL DEFINITION	SYMBOL	SYMBOL DEFINITION
	Contains button or coin cell battery. Hazardous if swallowed.		Protect from rain or wet conditions.
	First responder cut loop. Emergency Personnel/First Responder use only.		

LABELS

See Figure 1 for safety and maintenance labels which were on the vehicle when new. Refer to Table 7.

NOTE

Replacement labels can be purchased for your motorcycle. See a Harley-Davidson dealer. Some labels are available in different languages for destinations outside the United States.



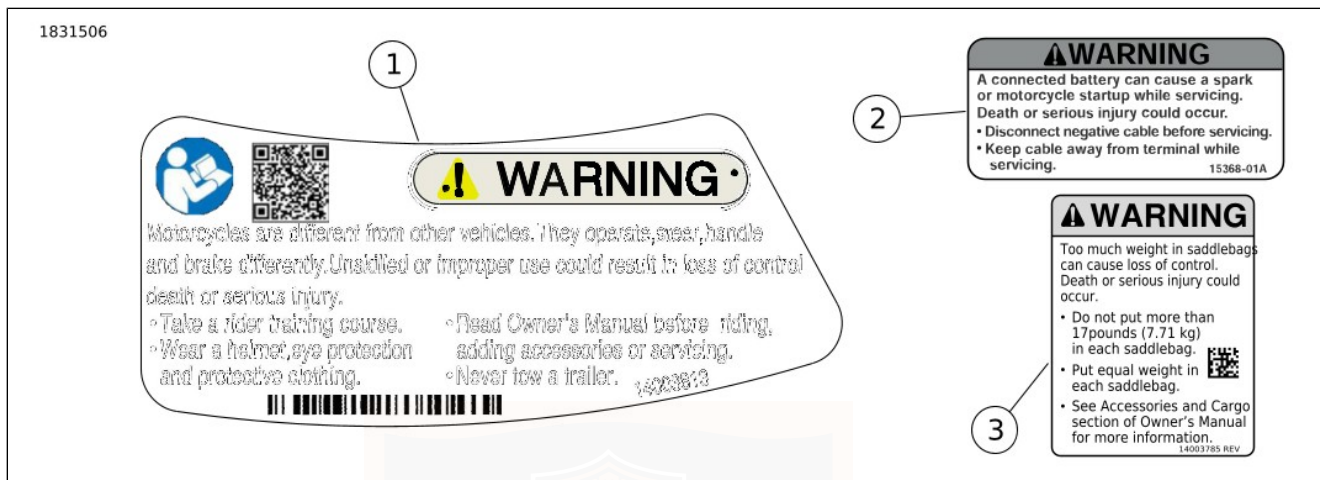

Figure 1. Labels

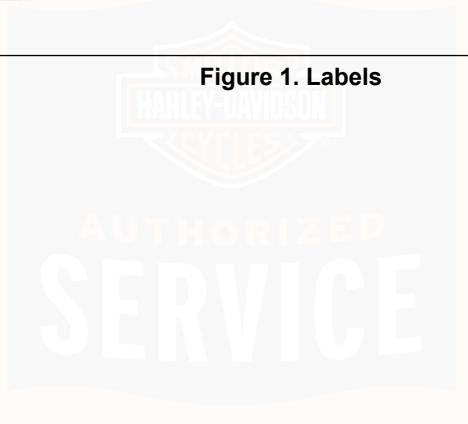

Table 7. Labels

ITEM	PART NO.	DESCRIPTION	LOCATION	TEXT
1	14003813	General warnings: Air cleaner	Top of air cleaner intake tube	<p>WARNING: Motorcycles are different from other vehicles. They operate, steer, handle and brake differently. Unskilled or improper use could result in loss of control death or serious injury.</p> <ul style="list-style-type: none">• Take a rider training course.• Read Owner's Manual before riding, adding accessories or servicing.• Wear a helmet, eye protection and protective clothing.• Never tow a trailer.
2	15368-01A	Battery warning	Under seat, behind fuel tank	<p>WARNING: A connected battery can cause a spark or motorcycle startup while servicing. Death or serious injury could occur.</p> <ul style="list-style-type: none">• Disconnect negative cable before servicing.• Keep cable away from terminal while servicing.
3	14003785	Saddlebag load limits	Inside saddlebag	<p>WARNING: Too much weight in saddlebags can cause loss of control. Death or serious injury could occur.</p> <ul style="list-style-type: none">• Do not put more than 17 pounds (7.71 kg) in each saddlebag.• Put equal weight in each saddlebag.• See Accessories and Cargo section of Owner's Manual for more information.

VEHICLE IDENTIFICATION NUMBER (VIN)

General

See Figure 3. A unique 17-digit serial or Vehicle Identification Number (VIN) is assigned to each motorcycle. For a description of each item in the VIN, refer to Table 8.

Location

See Figure 2. The full 17-digit VIN (1) is stamped on the right side of the frame near the steering head. In some destinations, a printed VIN label (2) is also attached to the front downtube.

Abbreviated VIN

An abbreviated VIN showing the vehicle model, engine type, model year, and sequential number is stamped on the left side of the crankcase between the engine cylinders.

NOTE

Always give the full 17-digit Vehicle Identification Number when ordering parts or making any inquiry about your motorcycle.

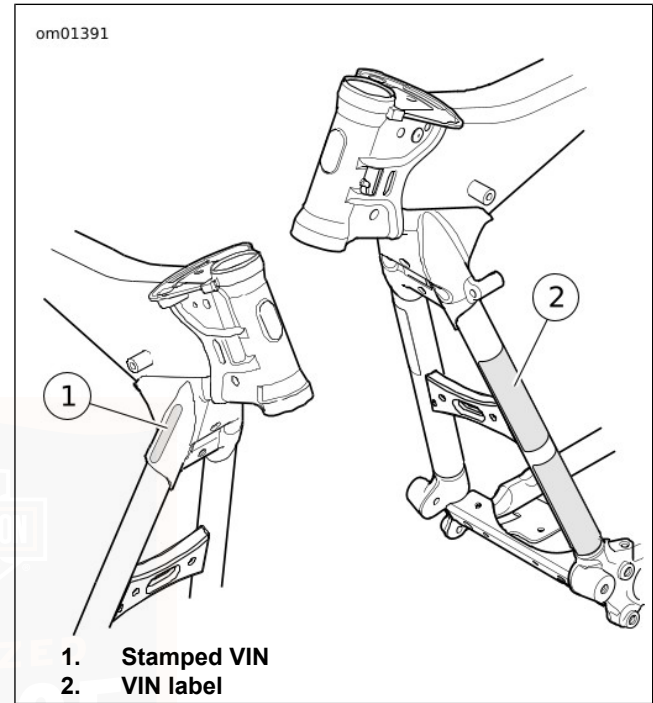

Figure 2. VIN Locations

①
②
③
④
⑤
⑥
⑦
⑧
⑨

1HD 1 TL 8 1 7 R B 111000

Figure 3. Typical Harley-Davidson VIN: 2024 CVO Road Glide ST (FLTRXSTSE)

Table 8. Harley-Davidson VIN Breakdown: 2024 CVO Road Glide ST (FLTRXSTSE)

POSITION	DESCRIPTION	POSSIBLE VALUES
1	World manufacturer identifier	1HD=Originally manufactured in the United States 5HD=Originally manufactured in the United States or Thailand for sale outside of the United States 932=Originally manufactured in Brazil MLY=Originally manufactured in Thailand
2	Motorcycle type	1=Heavyweight motorcycle (901 cm ³ or larger)
3	Model	TL=CVO [™] Road Glide [®] ST (FLTRXSTSE)
4	Engine type	8=Milwaukee-Eight [™] 121 engine, 1977 cm ³

Table 8. Harley-Davidson VIN Breakdown: 2024 CVO Road Glide ST (FLTRXSTSE)

POSITION	DESCRIPTION	POSSIBLE VALUES
5	Calibration/configuration, introduction	Normal Introduction 1=Domestic (DOM) 2=California (CAL) 3=Canada (CAN) 4=ENG/EN2/HDI/HD2/HD4 5=Japan (JPN) 6=Australia (AUS) 7=Brazil (BRZ) 8=Asia Pacific (APC) 9=IND/IN2 0=ASEAN (AZN) A=China (CHN) G=HD3
6	VIN check digit	Can be 0-9 or X
7	Model year	R=2024
8	Assembly plant	B=York, PA USA D=H-D Brazil-Manaus, Brazil (CKD) S=Tasit, Pluagdang, Rayong, Thailand
9	Sequential number	Varies

MODELS AND FEATURES

Some models, features or configurations shown in this manual may not be available in all markets.

PRIMARY CONTROLS AND SERVICE COMPONENTS

Familiarize yourself with the location of all the controls and service components on your motorcycle.

NOTE

Illustrations are for general reference only. Controls and service components shown are general locations and representations that do not show a specific model of motorcycle.

Harley-Davidson reserves the right to change specifications, equipment or designs at any time without notice and without incurring obligation.

See Figure 4 for rider controls and service components accessible when seated.

See Figure 5 for rider controls and service components accessible from the right.

See Figure 6 for rider controls and service components accessible from the left.



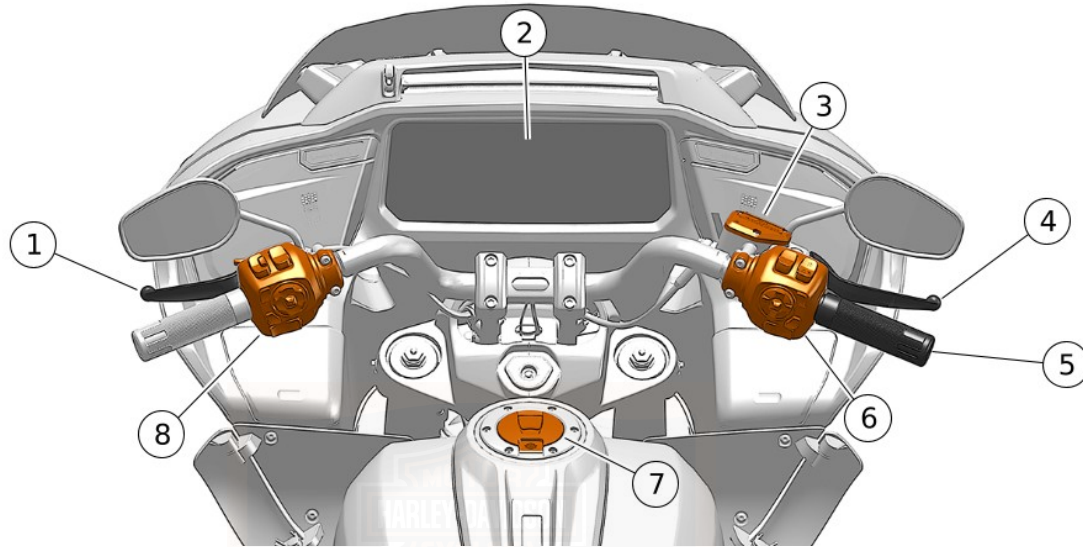

- | | |
|-------------------------------------|------------------------------|
| 1. Clutch lever | 5. Throttle twist grip |
| 2. Infotainment Control Unit (IFCU) | 6. Right hand control module |
| 3. Front brake fluid reservoir | 7. Fuel cap |
| 4. Front brake lever | 8. Left hand control module |

Figure 4. Controls and Service Components

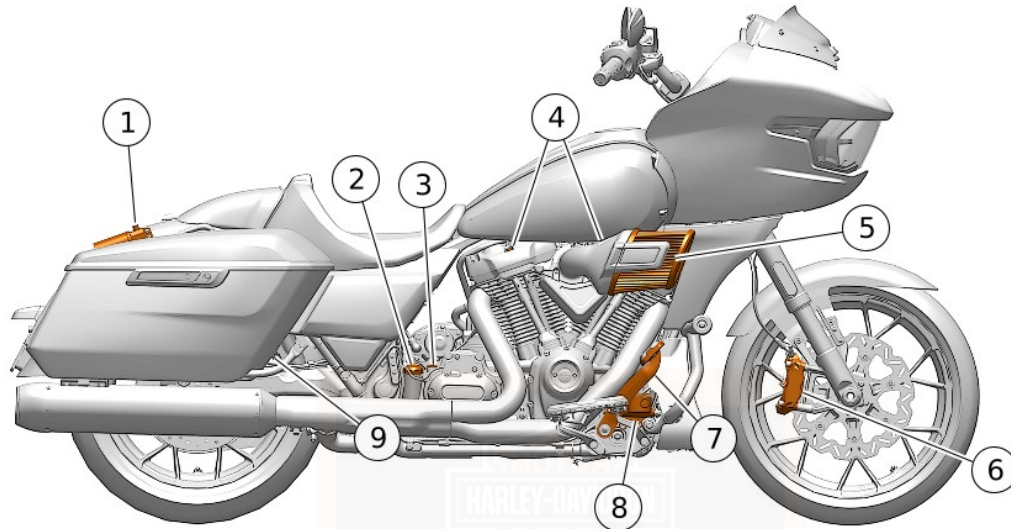

1. Right rear shock reservoir
2. Oil filler cap/dipstick
3. Transmission filler plug
4. Spark plug
5. Air cleaner

6. Front brake caliper
7. Rear brake pedal
8. Rear brake fluid reservoir
9. Rear brake caliper

Figure 5. Controls and Service Components

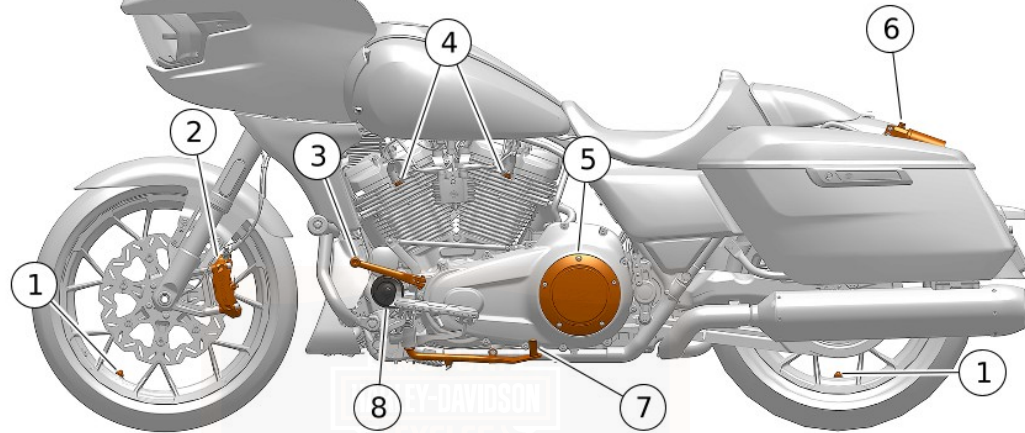

1. Air pressure valve
2. Front brake caliper
3. Gear shift lever
4. Spark plug

5. Clutch cover
6. Left rear shock reservoir
7. Jiffy stand
8. Horn

Figure 6. Controls and Service Components

NOTES



SPECIFICATIONS

NOTE

- Specifications in this publication may not match those of official certification in some markets due to timing of publication printing, variance in testing methods, and/or motorcycle differences. Customers seeking officially recognized regulatory specifications for their motorcycle should refer to certification documents and/or contact their respective dealer or distributor.

- Harley-Davidson reserves the right to change specifications, equipment or designs at any time without notice and without incurring obligation.

Tires

Table 9. Specified Tires

MOUNT	SIZE	APPROVED TIRE	PRESSURE (COLD 68 °F (20 °C))	
			psi	kPa
Front	19 in	Dunlop D408F BW 130/60B19 M/C 61H	36	248
Rear	18 in	Dunlop D407T BW 180/55B18 M/C 80H	40	276

- Do not use the TPMS as a pressure gauge when adding or removing air from a tire. Sensor data is sent to the TPMS at varying intervals which does not refresh immediately when adding or removing air from the tire. Over-inflation or under-inflation can result.
- The TPMS sensor will not communicate pressures above 50.0–60.0 psi (345–414 kPa) depending on altitude.
- Air is used to calibrate the TPMS. Use of 100 percent nitrogen may affect the accuracy of the system.
- Rotating valve stems from their properly installed positions can affect the valve stem seal and result in a slow leak. Do not rotate valve stems.
- Do not use liquid tire balancers or sealing agents in wheels with a TPMS sensor. Damage to the sensor can result.

▲ WARNING

Harley-Davidson recommends the use of its specified tires. Harley-Davidson vehicles are not designed for operation with non-specified tires, including snow, moped and other special-use tires. Use of non-specified tires can adversely affect stability, handling or braking and lead to loss of vehicle control, which could result in death or serious injury. (00024d)

Weights and Dimensions

Table 10. Weights

ITEM	lb	kg
Running weight ⁽¹⁾	838	380
Maximum additional weight allowed ⁽²⁾	522	237
GVWR	1360	617
GAWR front	500	227
GAWR rear	927	420

(1) The total weight of the motorcycle as delivered with all oil/fluids and approximately 90% of fuel.

(2) The total weight of accessories, cargo, riding apparel, passenger and rider must not exceed this weight.

Table 11. Dimensions

ITEM	in	mm
Overall length	94.9	2410
Overall width	36.4	925
Overall height	50.4	1280
Wheelbase	64.0	1625
Road clearance	5.1	130
Seat height*	26.7	678

* With 180 lb (81.6 kg) rider on seat.

Capacities

Table 12. Capacities

ITEM	U.S.	METRIC
Fuel tank (total)	6.0 gal	22.7 L
Low fuel warning light on (approximate)	1.0 gal	3.8 L
Engine oil capacity ⁽¹⁾	5.0 qt	4.7 L
Service oil change	4.75 qt	4.5 L
Coolant capacity	0.82 qt	0.78 L
Transmission (approximate) ⁽²⁾	1.0 qt	0.95 L
Primary chaincase (dry fill; approximate) ⁽³⁾	1.1 qt	1.0 L
<p><i>(1) When refilling, initially add 4.0 qt (3.8 L). Add more as needed to bring level within specification.</i></p> <p><i>(2) When refilling, initially add 28 fl oz (0.8 L). Add more as needed to bring level within specification.</i></p> <p><i>(3) Amount is approximate. Fill to bottom of pressure plate OD with vehicle upright.</i></p>		

Engine and Transmission

Table 13. Engine: Milwaukee-Eight™ 121

ITEM	SPECIFICATION	
Number of cylinders	2	
Type	4-cycle, 45 degree V-type Single camshaft Single balance shaft	
Compression ratio	11.4:1	
Bore	4.075 in	103.5 mm
Stroke	4.625 in	117.5 mm
Displacement	121 in ³	1977 cm ³
Fuel requirement	Premium unleaded	
Lubrication system	Pressurized, dry sump	
Cooling system	Liquid-cooled cylinder heads with frame mounted radiator and electric pump, oil cooled crankcase	

Table 14. Transmission

ITEM	SPECIFICATION
Type	Constant mesh, foot shift
Speeds	6 forward

Electrical

Table 15. Electrical

ITEM	SPECIFICATION	
Ignition timing	Not adjustable	
Battery	12 V, 28 Ah, 405 CCA sealed and maintenance free	
Charging system	58 A maximum output	
Spark plug size	10 mm	
Spark plug gap	0.031-0.035 in	0.80-0.90 mm
Spark plug torque	89-133 in-lbs	10-15 Nm



REMOVING MOTORCYCLE FROM STORAGE

1. Charge and install the battery. See SERVICE PROCEDURES > BATTERY MAINTENANCE (Page 209).
2. Inspect spark plugs. See MAINTENANCE AND LUBRICATION > REPLACING SPARK PLUGS (Page 205).
3. Inspect air filter and replace if necessary. See MAINTENANCE AND LUBRICATION > INSPECTING AIR FILTER (Page 203).
4. Inspect drive belt and sprocket. See MAINTENANCE AND LUBRICATION > CHECK DRIVE BELT DEFLECTION (Page 198).
5. Perform the items in the BEFORE RIDING > PRE-RIDE CHECKLIST (Page 35).

PRE-RIDE CHECKLIST

1. Check the amount of fuel in the tank. Add fuel if required. See BEFORE RIDING > FILLING THE FUEL TANK (Page 37).
2. Adjust mirrors to proper riding positions. See BEFORE RIDING > ADJUSTING MIRRORS (Page 48).

3. Check the engine oil level. See MAINTENANCE AND LUBRICATION > CHECK ENGINE OIL LEVEL (Page 177).
4. Check brake fluid level. See MAINTENANCE AND LUBRICATION > BRAKES (Page 190).
5. Inspect brake pads and discs for wear. See MAINTENANCE AND LUBRICATION > BRAKES (Page 190).
6. Check the hand and foot controls to be sure they are operating properly. Operate the front and rear brakes, throttle, clutch and shifter. See OWNER MANUAL > OPERATION (Page 69).
7. Inspect brake lines for wear or damage.
8. Check steering for smoothness by turning the handlebar through the full operating range.

⚠ WARNING

Be sure tires are properly inflated, balanced, undamaged, and have adequate tread. Inspect your tires regularly and see a Harley-Davidson dealer for replacements. Riding with excessively worn, unbalanced, improperly inflated, overloaded or damaged tires can lead to tire failure and adversely affect stability and handling, which could result in death or serious injury. (00014b)

9. Check tire condition, pressure and motorcycle loading. Refer to tire specifications in BEFORE RIDING > CHECKING TIRE PRESSURE AND INSPECTING TIRES (Page 43) for correct inflation pressure. Refer to SPECIFICATIONS > SPECIFICATIONS (Page 31) for weight allowances.
10. Check rear shock settings. Adjust if necessary. See BEFORE RIDING > ADJUSTING REAR SHOCK ABSORBERS (Page 52).
11. Check for any fuel, oil or hydraulic fluid leaks.
12. Check drive belt for wear or damage.

⚠ WARNING

Be sure headlamp, tail and stop lamp and turn signals are operating properly before riding. Poor visibility of rider to other motorists can result in death or serious injury. (00478b)

13. Check all electrical equipment and switches including the stop lamp, turn signals and horn for proper operation.
14. Service your motorcycle as necessary.

BREAK-IN RIDING RULES

The First 500 Miles (800 Kilometers)

The sound design, quality materials, and workmanship that are built into your new Harley-Davidson will give you optimum performance right from the start.

To allow your engine to wear-in its critical parts, we recommend that you observe the riding rules provided below for the first 500 mi (800 km).

1. During the first 50 mi (80 km) of riding, keep the engine speed below 3000 rpm in any gear. Do not lug the engine by running or accelerating at very low rpm, or by running at high rpm longer than needed for shifting or passing.

2. Up to 500 mi (800 km), vary the engine speed and avoid operating at any steady engine speed for long periods. Engine speed up to 3500 rpm in any gear is permissible.
3. Drive slowly and avoid fast starts at wide open throttle until the engine has warmed up.
4. Avoid lugging the engine by not running the engine at very low speeds in higher gears.
5. Avoid hard braking. Break-in new brakes with moderate use for the first 100 mi (160 km).

FILLING THE FUEL TANK

Review the following safety procedures. See SAFETY FIRST > SAFE OPERATING RULES (Page 3).

⚠ WARNING

Do not store motorcycle with gasoline in tank within the home or garage where open flames, pilot lights, sparks or electric motors are present. Gasoline is extremely flammable and highly explosive, which could result in death or serious injury. (00003a)

⚠ WARNING

Avoid spills. Slowly open fuel filler cap. Do not fill above bottom of filler neck insert, leaving air space for fuel expansion. Secure filler cap after refueling. Gasoline is extremely flammable and highly explosive, which could result in death or serious injury. (00028b)

⚠ WARNING

Do not use aftermarket fuel caps. Aftermarket fuel caps may fit improperly and leak, which could lead to death or serious injury. See a Harley-Davidson dealer for approved fuel caps. (00034a)

NOTICE

Do not spill fuel onto the motorcycle while refueling. Immediately wipe up fuel spills on your motorcycle. Fuel can cause damage to cosmetic surfaces. (00147b)

NOTICE

Use only unleaded fuel in catalytic converter-equipped motorcycles. Using leaded fuel will damage the emission control system. (00150c)

SERVICE

Fuel Filler Cap

Open: See Figure 7. Lift the latch (2) to open the fuel filler cap (1).

Filling: See Figure 8. Do not overfill the fuel tank. Insert the pump nozzle into the filler hole. Do not fill the tank beyond the bottom of the filler neck. A warm engine, the sun or extreme temperatures can cause the fuel to expand. Fuel can spill out of the tank and damage the finish. See SAFETY FIRST > SAFE OPERATING RULES (Page 3).

Close: To close the filler cap, push cap down firmly until latch clicks.

NOTE

To ensure fuel filler cap latch is properly engaged listen for audible click.

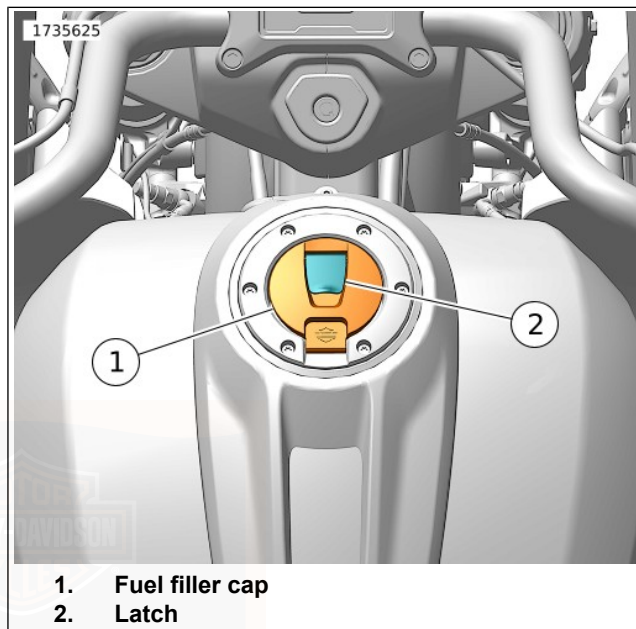

Figure 7. Installing/Removing Fuel Filler Cap: Flush Mount

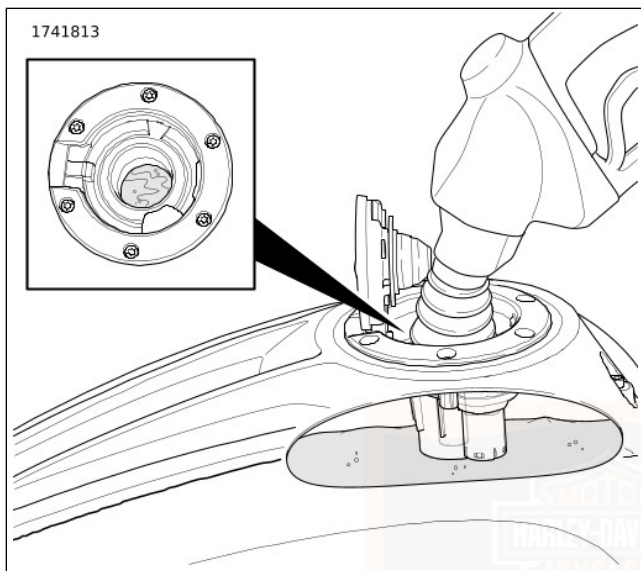

Figure 8. Fuel Level below Filler Neck

FUEL SYSTEM INFORMATION

Gasoline

Your motorcycle was designed to get the best performance and efficiency using unleaded gasoline. Most gasoline is blended with alcohol and/or ether to create oxygenated blends.

The type and amount of alcohol or ether added to the fuel is important.

NOTICE

Do not use gasoline that contains methanol. Doing so can result in fuel system component failure, engine damage and/or equipment malfunction. (00148a)

NOTICE

Use only unleaded fuel in catalytic converter-equipped motorcycles. Using leaded fuel will damage the emission control system. (00150c)

- ETHANOL fuel is a mixture of ethanol (grain alcohol) and unleaded gasoline and can have an impact on fuel mileage.
- REFORMULATED OR OXYGENATED GASOLINES (RFG) describes gasoline blends that are specifically designed to burn cleaner than other types of gasoline. This results in fewer tailpipe emissions. They are also formulated to reduce evaporative losses to the environment. Reformulated gasolines use additives to oxygenate the gas. Your motorcycle will run normally using this type of fuel. Harley-Davidson recommends using it whenever possible as an aid to cleaner air in our environment.



- Some gasoline blends might adversely affect starting, driveability or fuel efficiency. If any of these problems are experienced, try a different brand of gasoline or gasoline with a higher octane blend.

Table 16. Octane Rating

SPECIFICATION	RATING
Pump Octane (R+M)/2	91 (95 RON)



Table 17. Fuel Specification

Common Identifier	Specification	Rating
MTBE	Methyl Tertiary Butyl Ether	Gasoline/Methyl Tertiary Butyl Ether (MTBE) blends are a mixture of gasoline and as much as 15% MTBE. Gasoline/MTBE blends use in your motorcycle is approved.
Methanol	Methanol or Racing Fuel	Do not use racing fuel or fuel containing methanol; use of these fuels will damage the fuel system.
	5% Ethanol	Fuels with an ethanol content of up to 5% (E5) may be used in your motorcycle without affecting vehicle performance.
	10% Ethanol	Fuels with an ethanol content of up to 10% (E10) may be used in your motorcycle without affecting vehicle performance. United States customers: The United States' Clean Air Act prohibits the use of gasoline blends containing greater than 10% ethanol in motorcycles.
	22% Ethanol	Fuel in the Brazilian market has ethanol content which ranges from 21–27.5%. Harley-Davidson Motorcycles configured for Brazil are equipped with engine control calibrations developed to work properly with these fuels. Use of fuels with high ethanol content in Harley-Davidson motorcycles intended for other regulatory markets may result in poor drivability, setting of the check engine light and potential engine damage.
	85% Ethanol	Do not use fuel containing 85% ethanol. Use of these fuels will damage the fuel system and may lead to engine damage.

Catalytic Converter

Vehicles in some markets are equipped with catalytic converters.

NOTICE

Do not operate catalytic converter-equipped vehicle with engine misfire. If you operate the vehicle under this condition, the exhaust will become abnormally hot, which can cause vehicle damage, including emission control loss. (00149c)

ANTI-LOCK BRAKE SYSTEM (ABS)

Identification

Cornering rider safety enhancements equipped vehicles are also equipped with Anti-lock Braking System (ABS) and can be identified by a traction control switch on the left hand control module. See OPERATION > LEFT HAND CONTROL SWITCHES (Page 88) and Figure 9.

See OPERATION > CORNERING RIDER SAFETY ENHANCEMENTS (Page 123) for cornering rider safety enhancements operation.

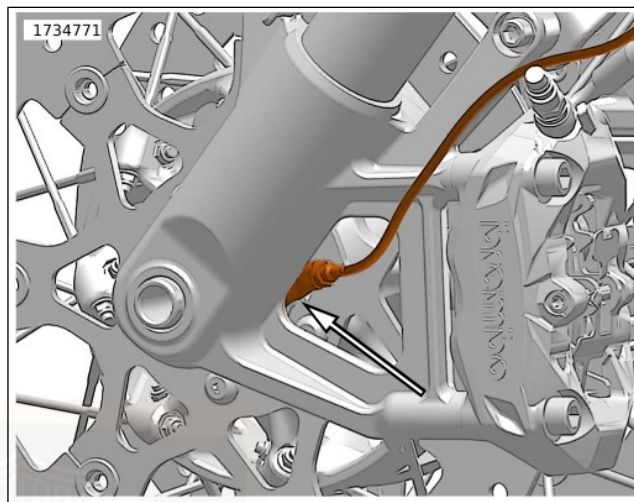

Figure 9. Wheel Speed Sensor (ABS identification typical)

CHECKING TIRE PRESSURE AND INSPECTING TIRES

General Information

⚠ WARNING

Match tires, tubes, rim strips or seals, air valves and caps to the correct wheel. Contact a Harley-Davidson dealer. Mismatching can lead to tire damage, allow tire slippage on the wheel or cause tire failure, which could result in death or serious injury. (00023c)

⚠ WARNING

Harley-Davidson front and rear tires are not the same. Interchanging front and rear tires can cause tire failure, which could result in death or serious injury. (00026a)

Tire Pressure

⚠ WARNING

Be sure tires are properly inflated, balanced, undamaged, and have adequate tread. Inspect your tires regularly and see a Harley-Davidson dealer for replacements. Riding with excessively worn, unbalanced, improperly inflated, overloaded or damaged tires can lead to tire failure and adversely affect stability and handling, which could result in death or serious injury. (00014b)

Tire pressures should be set using information in Table 18 and Table 19. Tires are considered Cold Tires if the vehicle has not been recently ridden. The tire pressure increases as the tire warms. Tires can warm due to both riding and high ambient air temperatures. Tires can remain warm for up to 2 hours after riding. For the most accurate reading, check tire pressures with a good gauge before riding while the tires are cold.

Check tire pressure:

- As part of the pre-ride checklist.
- At every scheduled service interval.

For Cold Tires with an Ambient Air Temp of 68 °F (20 °C) or less: Table 18

Table 18. Specified Tires

MOUNT	SIZE	APPROVED TIRE	PRESSURE (COLD 68 °F (20 °C))	
			psi	kPa
Front	19 in	Dunlop D408F BW 130/60B19 M/C 61H	36	248
Rear	18 in	Dunlop D407T BW 180/55B18 M/C 80H	40	276

- Do not use the TPMS as a pressure gauge when adding or removing air from a tire. Sensor data is sent to the TPMS at varying intervals which does not refresh immediately when adding or removing air from the tire. Over-inflation or under-inflation can result.
- The TPMS sensor will not communicate pressures above 50.0–60.0 psi (345–414 kPa) depending on altitude.
- Air is used to calibrate the TPMS. Use of 100 percent nitrogen may affect the accuracy of the system.
- Rotating valve stems from their properly installed positions can affect the valve stem seal and result in a slow leak. Do not rotate valve stems.
- Do not use liquid tire balancers or sealing agents in wheels with a TPMS sensor. Damage to the sensor can result.

For Cold Tires with an Ambient Air Temp higher than 68 °F (20 °C): Refer to the first column in Table 19 to determine the tire pressure adjustments. For example: If the motorcycle has not been ridden for 2 hours or more and the ambient temperature is 88 °F (31 °C), the recommended front and rear pressures are Table 18 pressures plus 2 psi (14 kPa).

Tires warm due to riding which increases the tire pressure. If the vehicle has been recently ridden, refer to the second column in Table 19 to determine the tire pressure adjustment. For example: If the motorcycle has been recently ridden and

the ambient temperature is 88 °F (31 °C), the recommended front and rear pressures are the Table 18 pressures plus 7 psi (48 kPa).

If a tire pressure adjustment is made when the vehicle has been recently ridden, re-adjust the tire pressure per recommendations when the tires have cooled. Tires can remain warm for up to 2 hours after riding.

Harley-Davidson does not perform any testing with only nitrogen in tires. Harley-Davidson neither recommends nor discourages the use of pure nitrogen to inflate tires.

Table 19. Tire Pressure Adjustment

AMBIENT AIR TEMPERATURE	MOTORCYCLE NOT RIDDEN FOR 2 HOURS OR MORE: ADD TO FRONT AND REAR PRESSURES IN SPECIFIED TIRES TABLE	MOTORCYCLE RECENTLY RIDDEN: ADD TO FRONT AND REAR PRESSURES IN SPECIFIED TIRES TABLE
68 °F (20 °C) or less	0 psi (0 kPa)	5 psi (34 kPa)
79 °F (26 °C)	1 psi (7 kPa)	6 psi (41 kPa)
88 °F (31 °C)	2 psi (14 kPa)	7 psi (48 kPa)
99 °F (37 °C)	3 psi (21 kPa)	8 psi (55 kPa)
108 °F (42 °C) or higher	4 psi (28 kPa)	9 psi (62 kPa)

Inspecting Tires

⚠ WARNING

Replace tire immediately with a Harley-Davidson specified tire when wear bars become visible or only 1/32 in (1 mm) tread depth remains. Riding with a worn tire could result in death or serious injury. (00090c)

Check tire tread:

- As part of the pre-ride checklist.
- At every scheduled service interval.

Inspect each tire for punctures, cuts and breaks.

Harley-Davidson tires are equipped with wear bars that run horizontally across the tread.

A tire is considered worn when the wear bars are visible or if only 0.031 in (1 mm) tread depth remains. A worn tire can:

- Be more easily damaged leading to tire failure.
- Provide reduced traction.
- Adversely affect stability and handling.

See Figure 10, Figure 11 and Figure 12. Always replace tires before the tread wear bars appear.

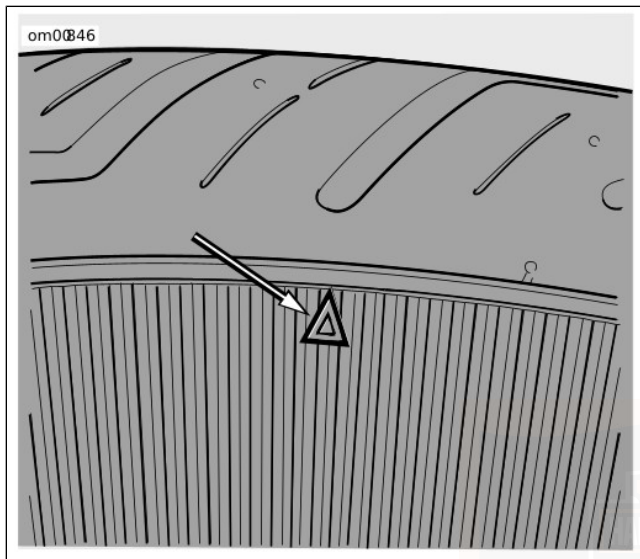

Figure 10. Dunlop Sidewall Tread Wear Indicator Bar Locator

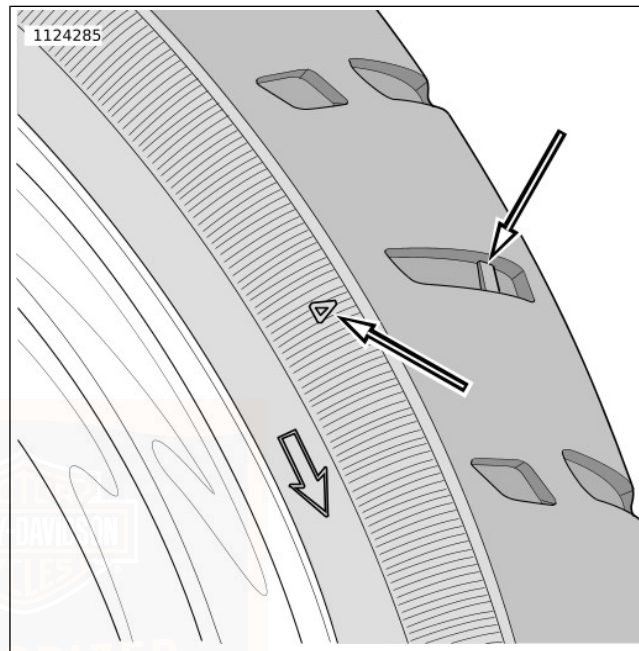

Figure 11. Tire Sidewall Wear Bar Locator

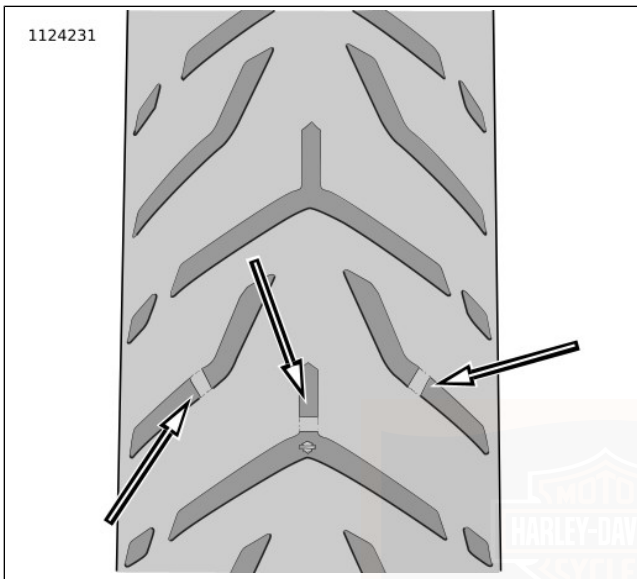

Figure 12. Wear Bar Appearance

Replacing Tires

⚠ WARNING

Tires are a critical safety component. Contact a Harley-Davidson dealer for tire repair or replacement. Improper tire service can adversely affect stability and handling, which could result in death or serious injury. (00057a)

⚠ WARNING

Harley-Davidson recommends the use of its specified tires. Harley-Davidson vehicles are not designed for operation with non-specified tires, including snow, moped and other special-use tires. Use of non-specified tires can adversely affect stability, handling or braking and lead to loss of vehicle control, which could result in death or serious injury. (00024d)

⚠ WARNING

Only install original equipment tire valves and valve caps. A valve, or valve and cap combination, that is too long or too heavy can strike adjacent components and damage the valve, causing rapid tire deflation. Rapid tire deflation can cause loss of vehicle control, which could result in death or serious injury. (00281a)

⚠ WARNING

Replace punctured or damaged tires. In some cases, small punctures in the tread area may be repaired from within the removed tire by a Harley-Davidson dealer. Speed should NOT exceed 50 mph (80 km/h) for the first 24 hours after repair, and the repaired tire should NEVER be used over 80 mph (129 km/h). Failure to follow this warning could lead to tire failure and result in death or serious injury. (00015b)

⚠ WARNING

Replace tire immediately with a Harley-Davidson specified tire when wear bars become visible or only 1/32 in (1 mm) tread depth remains. Riding with a worn tire could result in death or serious injury. (00090c)

New tires are needed if any of the following conditions exist (refer to Table 18 for the specified replacement tires):

- Tread wear bars become visible on the tread surfaces.
- Tire cords or fabric become visible through cracked sidewalls, snags or deep cuts.
- Bumps, bulges or slits in the tire.
- Punctures, cuts, or other damage to the tire that cannot be repaired.

When installing tires on rims, do not rely on tread design to determine direction of rotation. Always be sure the rotational arrows molded into the sidewalls point in the direction of rotation when the vehicle is moving forward.

ADJUSTING MIRRORS

⚠ WARNING

Objects in mirrors are closer than they appear. Use caution when judging distance of objects in mirrors. Failure to judge correct distances could result in death or serious injury. (00033a)

Your motorcycle has two convex rear view mirrors.

This type of mirror is designed to give a much wider view to the rear than a flat mirror. However, cars and other objects seen in this type of mirror look smaller and farther away than they actually are.

- Use caution when judging the size or relative distance of objects seen in rear view mirrors.
- Always adjust the rear view mirrors to reflect the area behind the motorcycle before riding.

NOTE

Adjust mirrors so you can see a small portion of your shoulders in each mirror. This will help you establish the relative distance of vehicles to the rear of your motorcycle.

OPERATING JIFFY STAND

Location

⚠ WARNING

Always park motorcycle on a level, firm surface. An unbalanced motorcycle can fall over, which could result in death or serious injury. (00039a)

⚠ WARNING

The jiffy stand locks when placed in the full forward (down) position with vehicle weight on it. If the jiffy stand is not in the full forward (down) position with vehicle weight on it, the vehicle can fall over which could result in death or serious injury. (00006a)

⚠ WARNING

Be sure jiffy stand is fully retracted before riding. If jiffy stand is not fully retracted, it can contact the road surface causing a loss of vehicle control, which could result in death or serious injury. (00007a)

NOTE

When parking your motorcycle on a grade, place the transmission in gear after turning off the engine.

See Figure 6. The jiffy stand is located on the left side of the motorcycle.

Jiffy Stand Switch (If equipped)

On models equipped with the jiffy stand interlock switch, the motorcycle will start and run with the jiffy stand down while the transmission is in neutral. If the jiffy stand is down and the transmission in gear, the engine will stall. Raising the jiffy stand or putting the transmission in neutral will permit the engine to run.

While the motorcycle is in motion at speeds greater than 15km/h (10mph), lowering the jiffy stand will not stop the engine.

TIRE PRESSURE MONITORING SYSTEM (TPMS)

NOTE

TPMS has been calibrated to use air in the tire. Use of 100 percent nitrogen may affect the accuracy of the system.

Each tire should be checked cold before riding and inflated to the inflation pressure recommended by Harley-Davidson in BEFORE RIDING > CHECKING TIRE PRESSURE AND INSPECTING TIRES (Page 43) and shown on the VIN/tire inflation pressure label (included on vehicles in US/Canada).

Your vehicle has been equipped with a tire pressure monitoring system (TPMS) that illuminates a low tire pressure lamp when one or more of your tires is significantly under-inflated. Accordingly, when the low tire pressure lamp illuminates, stop and check your tires as soon as possible, and inflate them to the proper pressure. Driving on a significantly under-inflated tire causes the tire to overheat and can lead to tire failure.

Under-inflation also reduces fuel efficiency and tire tread life, and may affect the vehicle's handling and stopping ability. It is important to set the tire pressure properly. Failure to do so can result in a low pressure alert at higher ambient air temperatures. Recommended cold tire pressures are shown in BEFORE RIDING > CHECKING TIRE PRESSURE AND INSPECTING TIRES (Page 43).

If tire pressure is to be checked when the vehicle has been recently ridden and the tires are warm, refer to BEFORE RIDING > CHECKING TIRE PRESSURE AND INSPECTING TIRES (Page 43) to determine corrected pressures. If hot tire pressure has been adjusted, re-adjust pressure per recommendations when tire has cooled.

TPMS is not a substitute for proper tire maintenance. It is the rider's responsibility to maintain correct tire pressure, even if under-inflation has not reached the level to trigger illumination of the TPMS low tire pressure lamp.

The vehicle has also been equipped with a TPMS fault indicator to indicate when the system is not operating properly. The TPMS fault indicator is combined with the low tire pressure lamp. When the system detects a fault, the low tire pressure lamp will flash for approximately one minute and then remain continuously illuminated. This sequence will continue upon subsequent vehicle start-ups as long as the malfunction exists. The security lamp will also turn on to indicate that a diagnostic trouble code exists. When the fault indicator is illuminated, the system may not be able to detect or signal low tire pressure as intended.

TPMS faults may occur for a variety of reasons, including the installation of replacement tires or wheels on the vehicle that prevent the TPMS from functioning properly.

Always check the TPMS fault indicator after replacing one or more tires or wheels on your vehicle to ensure that the replacement tires and wheels allow the TPMS to continue to function properly.

SUSPENSION ADJUSTMENTS

Suspension Definitions

Damping is set at the factory for the average solo rider under normal riding conditions. The rider may make adjustments to compensate for individual riding styles and varying road conditions.

Evaluating and changing the rebound and compression damping is a very subjective process with many variables and should be approached carefully.

Damping: Resistance to velocity of suspension movement. Damping affects how easily the suspension can move and limits oscillations of the system once movement has begun.

Compression: The suspension is compressed when the wheel moves upward (when riding over a bump).

Rebound: The suspension is rebounding when it is moving back from being compressed (rebounding to the road surface after a bump).

Preload: An adjustment made to the rear shock and front fork springs to limit vehicle and rider sag to a standard percentage of total suspension travel.

Suspension Tuning

Make all suspension adjustments in small increments. Radical setting changes may cause you to skip the best adjustment.

Refer to Table 20. Possible suspension and operating characteristics and their probable causes are listed. This table is helpful in keeping your motorcycle in good operating condition.

To achieve the proper settings you will need the preload properly adjusted, the tires properly inflated and a familiar bumpy road. It is useful if the road contains a variety of different kinds of bumps from small sharp bumps such as potholes or frost heaves to large cracks.

Table 20. Suspension Tuning

SUSPENSION CHARACTERISTICS	SOLUTION
Bike wallows through turns.	Increase rebound damping.
Bike feels loose or vague after bumps.	
Wheel tends to "pogo" or suffer continuous bouncing after passing a bump. This is often noticeable by watching the bike as it travels over bumps.	Reduce rebound damping.
Wheel responds to bump but doesn't return to ground quickly after bumps. This is more pronounced over a series of bumps and is often referred to as "packing down."	
Bike bottoms in dips or while cornering.	Increase compression damping.
Bike has excessive brake dive.	

Table 20. Suspension Tuning

SUSPENSION CHARACTERISTICS	SOLUTION
Harsh ride, particularly over washboard surfaces.	Reduce compression damping.
Bumps transfer through handlebars or seat.	
Suspension seems not to respond to bumps. Tires chatter through corners or rider is jolted over rough roads.	

Changes in Load

The front and rear preload setting will need to be adjusted for the rider's weight and cargo. This adjustment should be made before the motorcycle is ridden any distance and after changing the overall vehicle weight (adding saddlebags, etc.).

Changes in the load carried require changes in the preload settings. Carrying less weight than was used for setting up the suspension requires decreasing the amount of preload. Increasing the load carried requires adding more preload.

ADJUSTING REAR SHOCK ABSORBERS

NOTE

Do not overtighten shock absorber adjusters. Overtightening could result in damage to shock absorbers.

Preload Adjustment

Adjust the shock absorber preload for the total weight the motorcycle is to carry.

- Increase the preload to accommodate more weight.
- Reduce the preload if carrying less weight.

Suspension preload is set on both shocks via threaded preload adjusters.

Preload is used to set the suspension preload for the primary loading condition. This includes:

- Rider only
- Rider + Passenger
- Rider + Cargo
- Rider + Passenger + Cargo

1. Remove saddlebags. Refer to: OPERATION > SADDLEBAGS (Page 133).
2. Determine the primary loading condition that the vehicle will most often be used in (Rider Only, Rider + Passenger, Rider + Cargo or Rider + Passenger + Cargo).

3. Calculate preload distance. Refer to Table 21.
4. See Figure 13. Turn the lock ring (1) on right shock CCW to MIN using the provided spanner wrench tool.
5. Turn the adjustment ring (2) CW until the distance from the top of the adjustment ring to the bottom of the lock ring matches the calculated preload distance determined in steps 2 and 3. Refer to Table 21.
6. Holding adjustment ring in place, turn lock ring CW and tighten against adjustment ring using the spanner wrench tool.
7. Repeat steps 4 through 6 on the left shock.
8. Install saddlebags. Refer to: OPERATION > SADDLEBAGS (Page 133).

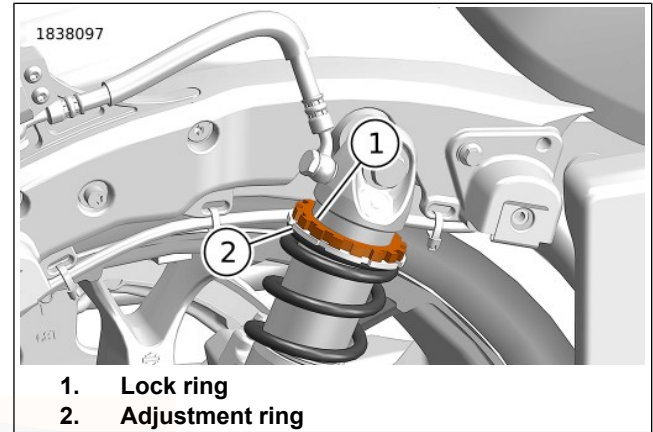

Figure 13. Preload Adjuster

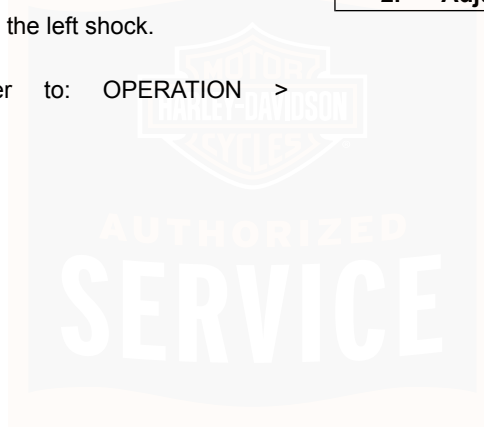

Table 21. Rear Shock Absorbers Threaded Preload Adjuster Settings for Rider/Passenger

		ADDITIONAL WEIGHT OF PASSENGER																			
		LB	0	10	20	30	40	50	60	70	80	90	100	110	120	130	140	150	160	170	180
		KG	0	5	9	14	18	23	27	32	36	41	45	50	54	59	64	68	73	77	82
RIDER WEIGHT																					
LB	KG	mm Between Top of Adjuster Ring and Bottom of Lock Ring																			
150	68	4	5	6	7	9	10	11	12	13	14	15	15	17	18	19	20	21	22	23	24
160	73	5	6	7	8	9	11	12	13	14	15	16	17	18	20	21	22	23	24	25	
170	77	6	7	8	9	10	11	12	14	15	16	17	18	19	20	22	23	24	25	26	
180	82	7	8	9	10	11	12	13	14	16	17	18	19	20	21	22	24	25	26	27	
190	86	7	8	10	11	12	13	14	15	16	18	19	20	21	22	23	24	25	27	28	
200	91	8	9	10	12	13	14	15	16	17	18	20	21	22	23	24	25	26	27	29	
210	95	9	10	11	12	14	15	16	17	18	19	20	21	23	24	25	26	27	28	29	
220	100	10	11	12	13	14	15	17	18	19	20	21	22	23	25	26	27	28	29	30	
230	104	11	12	13	14	15	16	17	19	20	21	22	23	24	25	27	28	29	30	31	
240	109	11	13	14	15	16	17	18	19	21	22	23	24	25	26	27	28	30	31	32	
250	113	12	13	15	16	17	18	19	20	21	22	24	25	26	27	28	29	30	32	33	
260	118	13	14	15	17	18	19	20	21	22	23	24	26	27	28	29	30	31	32	34	
270	122	14	15	16	17	18	20	21	22	23	24	25	26	28	29	30	31	32	33	34	
280	127	15	16	17	18	19	20	22	23	24	25	26	27	28	30	31	32	33	34	35	
290	131	16	17	18	19	20	21	22	24	25	26	27	28	29	30	31	33	34	35	39	

Damping Adjustments

Both shock absorbers have compression and rebound damping adjusters to obtain ideal suspension performance across a range of rider preferences and loading conditions. The damping adjusters should be set to the same setting on each shock.

- Increase compression and rebound damping adjuster setting for increased Rider / Passenger / Cargo weight or a stiffer ride.
- Reduce compression and rebound damping adjuster setting for decreased Rider / Passenger / Cargo weight or a softer ride.

1. Remove saddlebags. Refer to: OPERATION > SADDLEBAGS (Page 133).
2. See Figure 14. Compression damping adjustment.
 - a. Turn the compression damping adjuster on both shock absorbers to the MAX setting (full CLOCKWISE), then turn back COUNTERCLOCKWISE to the first click.
 - b. Turn the compression damping adjusters on both shocks COUNTERCLOCKWISE to the target number of clicks from MAX based on rider preference or loading condition. Refer to Table 22.
3. See Figure 15. Rebound damping adjustment.
 - a. Turn the rebound damping adjuster on both shock absorbers to the MAX setting (full CLOCKWISE), then turn back COUNTERCLOCKWISE to the first click.
 - b. Turn the rebound damping adjusters on both shocks COUNTERCLOCKWISE to the target number of clicks from MAX based on rider preference or loading condition. Refer to Table 22.
4. Install saddlebags. Refer to: OPERATION > SADDLEBAGS (Page 133).

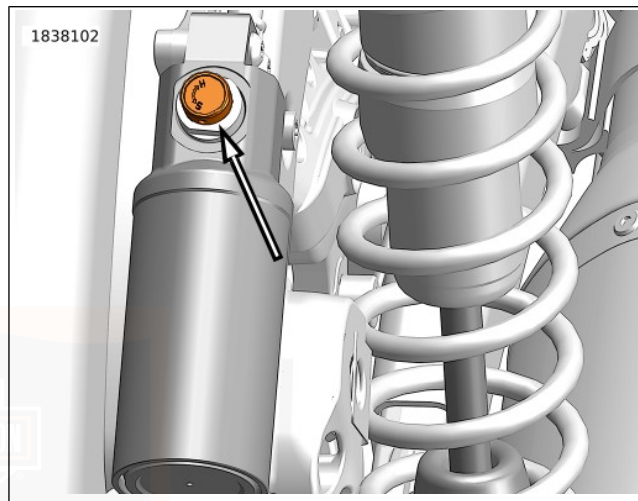

Figure 14. Compression Adjuster

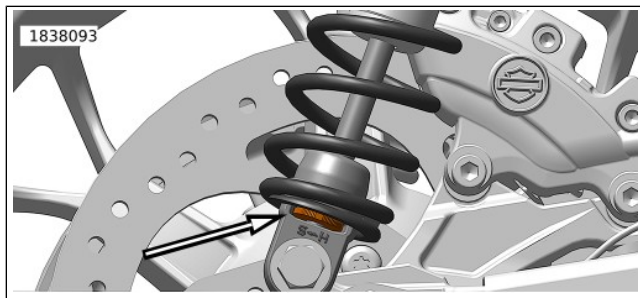

Figure 15. Rebound Adjuster

Table 22. Rear Shock Compression and Rebound

	RIDE SETTING	REAR SHOCK ⁽¹⁾	
		Compression	Rebound
Solo	Standard	26	14
	Comfort	22	8
	Sport	14	5
	Luggage	10	4
With passenger		8	2

(1) Damping adjuster settings are done by turning adjuster clockwise until it stops at the maximum setting, then counting the clicks counter-clockwise to the desired setting.

ADJUSTING FRONT SHOCK ABSORBERS

Front Fork

General

Your vehicle is equipped with adjustable front forks that have adjusters at the top of each fork.

See Figure 16.

Damping is set at the factory for the average solo rider under normal riding conditions. The rider may make adjustments to compensate for load, individual riding styles and varying road conditions.

Evaluating and changing the rebound and compression damping is a subjective process with many variables and should be approached carefully.

NOTICE

Compression and rebound adjusting valves may be damaged if too much force is used at either end of the adjustment range. (00237a)

NOTE

Do not force adjusters beyond mechanical stops.

Compression and Rebound Damping

Compression Damping Adjustment

See Figure 16. The compression adjuster (2) screw is located on the top of the right side fork tube.

1. Turn compression adjuster screw clockwise until it stops. This is the maximum compression damping setting.
2. Turn compression adjuster screw counter-clockwise the recommended number of turns. Table 24

Rebound Damping Adjustment

See Figure 16. The rebound adjuster (3) screw is located on the top of the left side fork tube.

1. Turn rebound adjuster screw clockwise until it stops. This is the maximum rebound damping setting.
2. Turn rebound adjuster screw counter-clockwise the recommended number of turns. Table 24

Spring Preload

NOTE

Make identical preload adjustments to left and right forks.

See Figure 16. The preload adjuster (1) is located on the top of each fork tube.

1. Turn preload adjuster counter-clockwise until it stops. This is the minimum preload setting.
2. Determine front preload setting. Refer to Table 23.
3. Turn preload adjuster clockwise the calculated number of turns.

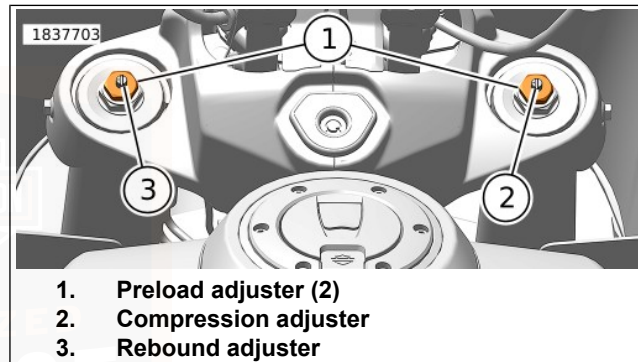

Figure 16. Front Suspension Adjusters

Table 23. Front Preload Suspension Settings

RIDER WEIGHT	FRONT FORKS
kg/lb	Turns from Minimum ⁽¹⁾
150 lb (68 kg)	2.0
160 lb (73 kg)	3.0
170 lb (77 kg)	3.5
180 lb (82 kg)	4.0
190 lb (86 kg)	4.5
200 lb (91 kg)	5.0
210 lb (95 kg)	6.0
220 lb (100 kg)	6.5
230 lb (104 kg)	7.0
240 lb (109 kg)	7.5
250 lb (113 kg)	8.0
260 lb (118 kg)	8.5
270 lb (122 kg)	9.5
280 lb (127 kg)	10.0
290 lb (132 kg)	10.5

(1) Number of clockwise turns from minimum preload setting.

Table 24. Front Forks Compression and Rebound

RIDE SETTING	FRONT FORKS ⁽¹⁾	
	Compression (right fork)	Rebound (left fork)
Standard	2	2.5
Comfort	1	1.5
Sport	0.5	0.5

(1) Damping adjuster settings are done by turning adjuster clockwise until it stops at the maximum setting, then counting the turns counter-clockwise to the desired setting.

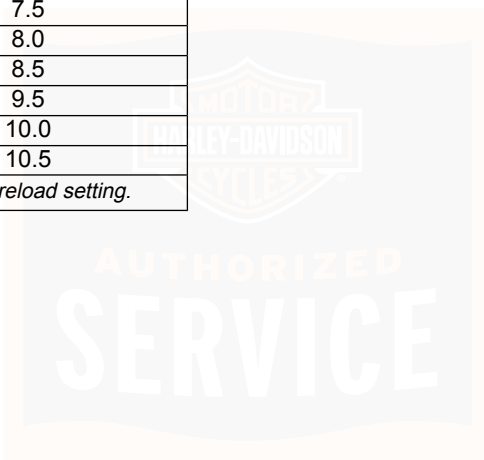

SECURITY SYSTEM

Components

The security system consists of a control module, a hands-free antenna mounted on the motorcycle and a hands-free fob carried by the rider.

See SECURITY SYSTEM > ARMING AND DISARMING (Page 62).

Options

See a Harley-Davidson dealer or www.harley-davidson.com for security system options.

SECURITY SYSTEM FOB

▲ WARNING



CONTAINS BUTTON OR COIN CELL BATTERY. KEEP OUT OF REACH OF CHILDREN.

Ingestion can result in death or serious injury. Choking, chemical burns and perforation of soft tissue may result. Severe burns can occur within 2 hours of ingestion or placement in any part of the body. Seek medical attention immediately. (13105b)

Assigning Fob

See Figure 17. Key fobs are electronically assigned to the security system by a Harley-Davidson dealer. Only two fobs can be assigned at any one time.

Purchase replacement fobs from a Harley-Davidson dealer. The fobs can only be assigned to an individual motorcycle by a trained Harley-Davidson technician.

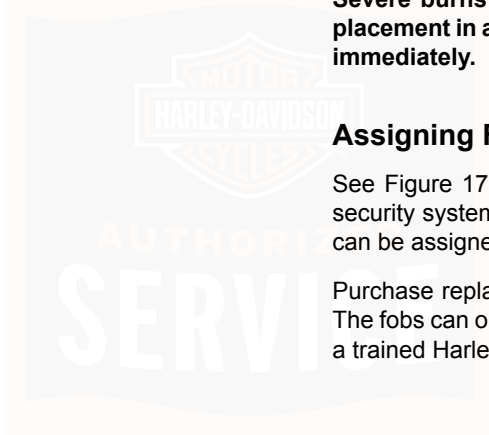

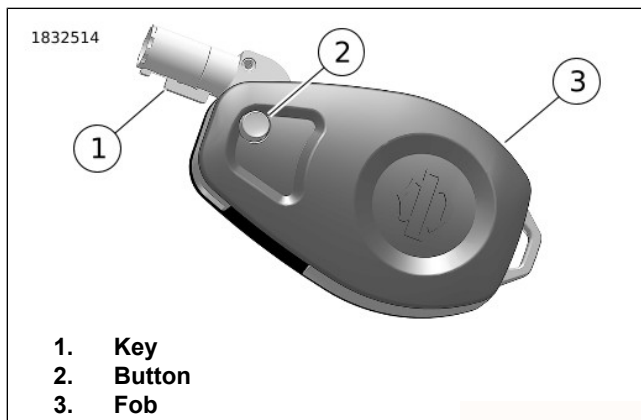

Figure 17. Key Operation

NOTE

- The module will arm only if the fob has been assigned by a Harley-Davidson dealer and a Personal Identification Number (PIN) has been entered in the system. Record the PIN on the Personal Information page in the front of this Owner's Manual and on the removable wallet card.
- If the fob is misplaced or fails, the rider can refer to the wallet card and use the PIN to manually disarm the system. See SECURITY SYSTEM > ARMING AND DISARMING (Page 62) and SECURITY SYSTEM > TROUBLESHOOTING (Page 66).

- The rider can change the PIN at any time. See SECURITY SYSTEM > PERSONAL IDENTIFICATION NUMBER (PIN) (Page 61).

Riding with a Fob

- Always carry the fob when riding, loading, fueling, moving, parking or servicing the motorcycle.
- Do not leave the fob attached to the handlebars or store the fob in a luggage compartment. Unintentionally leaving the fob with the motorcycle when it is parked prevents the system from activating the alarm.
- Do not ride with the fob stored in a metal case or with the fob closer than 76 mm (3.0 in) to a mobile phone, PDA, display or other electronic device. Any electromagnetic interference may prevent the fob from disarming the system.
- For added security, always lock the fork and remove the key when parked. If the fob is within range and the motorcycle is unlocked, tampering with the motorcycle will not activate the alarm.

Riding without a Fob

If the motorcycle is ridden without the fob in acceptable proximity, the IFCU will display a pop up warning showing

"NO FOB". To restart a motorcycle without a fob, disarm the security system with the PIN.

PERSONAL IDENTIFICATION NUMBER (PIN)

The Personal Identification Number (PIN) is a number that can be used to disarm the security system. Use the PIN in case the assigned fob is misplaced, fails or if the fob cannot communicate with the motorcycle because of electromagnetic interference.

NOTE

Record and memorize your PIN. If the fob is lost or the fob battery dies, the PIN is needed to operate the motorcycle. If the fob is lost, a new fob cannot be assigned without the PIN.

A PIN is a five-digit number (1-9).

Changing the PIN

The rider can change the PIN at any time.

- Ignition must be ON.
- Fob must be present.
- Numbers between 1 and 9 can be selected (the digit 0 cannot be used in a PIN).

1. Select a 5-digit (1-9) PIN and record on the wallet card from the owners manual.
2. In the IFCU, navigate to **Settings > General Settings > System Info**. At the **System Info** screen, select **Change Security PIN**.
3. See Figure 18. The **Change PIN** screen is displayed.

Touch Screen Entry

1. Touch digit on the PIN entry keypad, digit will be shown on the PIN display.
2. Repeat step 1 until all five-digits are filled in with the desired PIN.
3. Cycle the ignition to save the PIN.

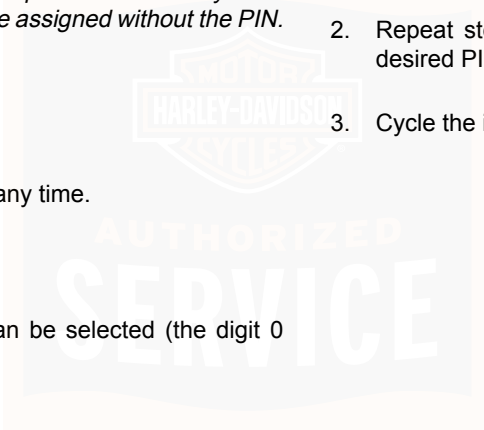



Figure 18. Change PIN Screen

ARMING AND DISARMING

Arming

When the motorcycle is parked and the OFF switch is pressed, the security system arms automatically within 5 seconds if no motion is detected. Even when the fob is present, the system arms.

On arming, the turn signals flash twice, and the siren chirps twice (if the siren is in the chirp mode).

NOTE

International models: The system must be in the chirp mode for the siren to chirp on arming or disarming (if equipped with a siren). See SECURITY SYSTEM > SIREN CHIRP MODE (CONFIRMATION) (Page 65).

Disarming

With the fob present, the rider may ride or move the motorcycle for parking, storage, or service without activating the alarm. Disarming is automatic if the fob is within range.

Fob: An armed security system is automatically disarmed when the fob is present, and the motorcycle is moved, or the RUN switch is pressed.

The range of the fob is approximately 5 ft (1.5 m).

When the system disarms, the turn signals flash once, and the siren chirps once (if the siren is in the chirp mode).

PIN: If the fob is misplaced or if the present fob fails to communicate, the system can be disarmed with the PIN.

Disarming with a PIN

Disarm the security system manually by using the PIN if the fob is lost, the fob battery is discharged or if where you parked there is a strong electromagnetic interference.

Do not turn handlebars, straddle seat or lift motorcycle off the jiffy stand. During a PIN disarm, if the security system detects motorcycle motion, the system will activate the alarm.

The PIN screen is automatically displayed on the IFCU when the fob is not present, and an attempt is made to turn the vehicle ON.

NOTE

- If a mistake is made while entering PIN, set the OFF/RUN/START switch to OFF before entering the last digit. Then start the procedure from the beginning.
- If the procedure fails to disarm the security system, wait 2 minutes before attempting another PIN disarm.
- Once the security system is disarmed, it remains disarmed until the OFF/RUN/START switch is set to OFF.
- At any time during a PIN disarm if the fob is brought within range, the security system disarms as the module receives the coded signal from the fob.

Touch Screen Entry

1. See Figure 19. Touching the IFCU screen will display PIN digit display (1) and the keypad (2).
2. See Figure 20 and Figure 21. Using the on-screen keypad, enter the complete five-digit PIN.

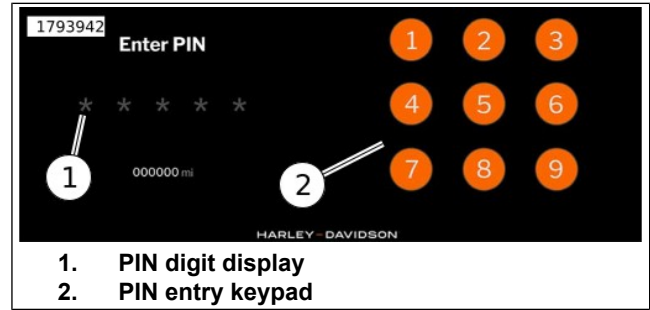

Figure 19. PIN Entry Screen

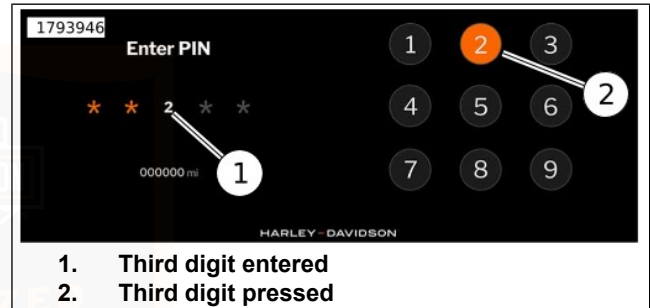

Figure 20. Entering PIN Digits



Figure 21. Five Digit PIN Entered

ALARM

Warnings

Once armed, if the motorcycle is moved or lifted up off of its jiffy stand and the fob is not present, the alarm will warn the operator with three alternate flashes of the turn signals and a chirp of the siren.

Within four seconds, if the motorcycle is back on its jiffy stand and no further motion is detected, the system will remain armed without activating the alarm.

If the motorcycle motion continues, the system will issue a second warning four seconds after the first.

NOTE

During warnings and alarms, the starter motor and the ignition circuits remain disabled.

Alarm Activation

If the security system is still detecting motion after a second warning, the system will activate the alarm.

When activated, the security system will:

- Alternately flash the four turn signals.
- Sound the siren.

Duration: The alarm will stop within 30 seconds and if no motion is detected, the alarm will not restart.

However, if motorcycle motion continues the system will repeat the 30 second alarm and recheck for motion. The alarm will repeat this 30 second alarm cycle for five minutes (10 cycles) or until the alarm is deactivated.

NOTE

The alarm will also activate the LED, vibration or audible modes of an optionally purchased Harley-Davidson Security Pager. The range of a pager can be up to $\frac{1}{2}$ mi (0.8 km). See a Harley-Davidson dealer for details.

Alarm Deactivation

Key fob: Bring the fob to the motorcycle. After the module identifies that the fob is present, the system will terminate the alarm.

PIN entry: Enter the PIN to deactivate the alarm. If an error is made while entering the PIN, wait until the alarm is between cycles to enter the PIN.

SIREN CHIRP MODE (CONFIRMATION)

The siren sounds two chirps when arming, and a single chirp when disarming.

TRANSPORT MODE

It is possible to arm the security system without enabling the motion detector for one ignition cycle. The motorcycle can be moved in an armed state. The motorcycle cannot be turned on or started while in transport mode until the fob is present.

To Enter Transport Mode

1. With security fob present, set the OFF/RUN/START switch to RUN.
2. Set the OFF/RUN/START switch to OFF.
3. Simultaneously press both the left turn signal and the flash-to-pass switches within five seconds of turning the OFF/RUN/START switch to OFF.
4. See Figure 22. Once activated, a transport mode icon will be displayed on the IFCU to indicate that the security system is in transport mode.

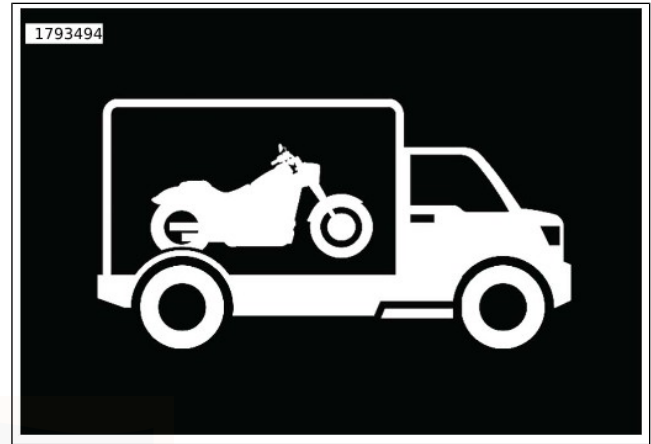

Figure 22. Transport Mode Display

To Exit Transport Mode

With the fob present, set the OFF/RUN/START switch to RUN to disarm the system and exit transport mode.

STORAGE AND SERVICE DEPARTMENTS

Long-Term Parking

To maintain arming, store the fob beyond the range of the antenna. The antenna range is approximately 5 ft (1.5 m). Have the fob present before moving parked motorcycle.

If the motorcycle will not be operated for several months, such as during the winter season, see AFTER RIDING > STORING MOTORCYCLE (Page 172).

Service Departments

When the motorcycle is left at a Harley-Davidson dealer, there are two options:

1. Leave an assigned fob with the dealer.
2. To maintain possession of the fob, ask the dealer to disable the system for service (service mode) before leaving the dealership. Once service mode is active, the vehicle can be operated without an assigned fob present. To maintain the service mode, the assigned fobs must be kept out of range. If the fob appears in range, the service mode is cancelled.

DISCONNECTING POWER

All Models

When disconnecting the battery or removing the main fuse, perform the following steps.

1. Verify that the fob is present.
2. Set the OFF/RUN/START switch to RUN.
3. Pull the main fuse from its holder.

4. Disconnect the battery if needed.

NOTE

Set the OFF/RUN/START switch back to OFF before installing main fuse.

TROUBLESHOOTING

Fob

If the security system continues to actuate warnings and alarms with the fob present, check for:

1. **Electromagnetic interference:** Other electronic devices, power lines, or other electromagnetic sources can cause the security system to operate inconsistently.
 - a. Verify that the fob is not in a metal enclosure or within 3 in (76 mm) of any other electronic devices.
 - b. Place the fob on the seat and set the OFF/RUN/START switch to RUN. After the system disarms, return the fob to a convenient location.
 - c. Move motorcycle at least 16 ft (5 m) from the spot of interference.
2. **Discharged fob battery:** Use the PIN to disarm the system. Replace the battery. See SECURITY SYSTEM > SECURITY SYSTEM FOB (Page 59).

3. **Damaged fob:** Use the PIN to disarm the motorcycle. Replacement fobs are available for purchase from a Harley-Davidson dealer.

Siren

- If the siren does not chirp two or three times on a valid arming command from the security module, the siren is either not connected, not working, or the siren wiring was opened or shorted while the siren was disarmed.
 - If the siren is armed and the internal siren battery is dead, shorted, disconnected, or has been charging for a period longer than 24 hours, the siren will respond with three chirps on arming instead of two.
- The internal siren battery may not charge if the vehicle's battery is less than 12.5 V.
 - If the siren enters the self-driven mode where it is powered from the siren's internal 9 V battery, the turn signal lamps may or may not alternately flash. If the security module activates the siren, the turn signal lamps will alternately flash. If the siren has been armed and a security event occurs, and the siren is in self-driven mode, the siren will alarm 20–30 seconds and then turn off for 5–10 seconds. This alarm cycle will be repeated ten times if the siren is in the self-driven mode.

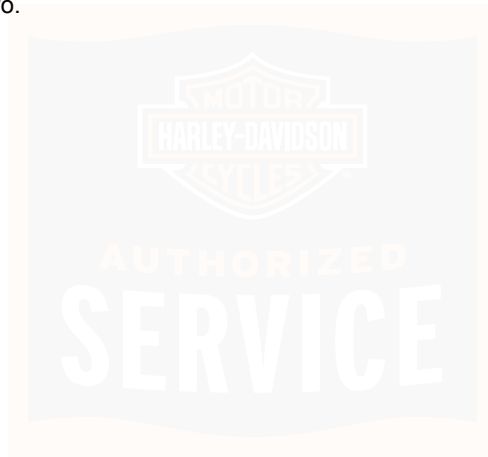

NOTES



KEYLESS IGNITION

⚠ WARNING

The automatic-on headlamp feature provides increased visibility of the rider to other motorists. Be sure headlamp is on at all times. Poor visibility of rider to other motorists can result in death or serious injury. (00030b)

⚠ WARNING

Do not operate vehicle with forks locked. Locking the forks restricts the vehicle's turning ability, which could result in death or serious injury. (00035a)

The motorcycle has keyless ignition. A key is not required to operate the motorcycle. Instead, an assigned key fob must be present or the PIN must be used before the motorcycle can be started.

Ignition Mode

See Figure 33. With the key fob present and the fork lock rotated fully to the unlocked position, set the OFF/RUN/START switch to RUN. The lights and instruments become operational and the engine can be started. To disarm the security system using the PIN, see SECURITY SYSTEM > ARMING AND DISARMING (Page 62).

The motorcycle remains ON (or the engine continues running) until the OFF/RUN/START switch is set to OFF. Taking the key fob out of range will not shut down the engine or turn off the motorcycle after it is turned on. However, the IFCU displays a NO FOB message if the motorcycle is driven away without the key fob present.

When parked, set the OFF/RUN/START switch to OFF and take the key fob away from the motorcycle to prevent unauthorized startup. With the motorcycle turned off and the key fob out of range, the starter, ignition system and OFF/RUN/START switch remain disabled, immobilizing the motorcycle.

Accessory Mode

See Figure 32. With the key fob present, press and hold the trip switch. The instruments and accessory circuit are powered. The headlamp and turn signal lamps remain off. While in accessory mode, the IFCU displays the fuel gauge and odometer functions. The headlamp can be activated by pressing the headlamp flash to pass switch.

To turn the motorcycle back off, press and hold the trip switch.

Do not leave the motorcycle in accessory mode for an extended time. This can discharge the battery. If the vehicle is left in accessory mode for 2 hours, the motorcycle automatically shuts off to prevent complete battery discharge.

To resume accessory mode, press and hold the trip switch again.

KEY FOB

The motorcycle comes from the factory with two key fobs. The key fobs have been electronically assigned by your dealer to disarm the security system for your motorcycle. Only two fobs can be assigned to a motorcycle at any one time. Replacement key fobs can be purchased and assigned for your motorcycle by a Harley-Davidson dealer.

A unique number is attached to a tag on the key fobs. Write your key fob number in the space provided in the front of this manual.

Retractable Key

The retractable key can be used to manually lock and unlock the fork lock and saddlebags.

Extend key: See Figure 23. Press the button (2) to extend the key.

Retract key: Press the button to release the key. Rotate the key back into the fob body.

Security System

The security system can be disarmed when an assigned key fob is within range. Always carry the fob when riding, loading,

fueling, moving, parking or servicing the motorcycle. The range for disarming the security system is approximately 5 ft (1.5 m) from the center of the motorcycle.

See OPERATION > KEYLESS IGNITION (Page 69) to operate the motorcycle. See OWNER MANUAL > SECURITY SYSTEM (Page 59) for a complete description of security system features.

Riding away without the fob: The IFCU temporarily shows NO FOB if the motorcycle is ridden away without the key fob. To restart a motorcycle without a key fob, disarm the security system with the PIN. See SECURITY SYSTEM > ARMING AND DISARMING (Page 62).

Removing key fob when parked: Always lock the fork and remove the key fob when parked. Do not leave the key fob attached to the handlebars or stored in a luggage compartment. If the key fob is within range, the motorcycle can be started and the alarm will not activate.

Replacing the Battery

⚠ WARNING



CONTAINS BUTTON OR COIN CELL BATTERY. KEEP OUT OF REACH OF CHILDREN.

Ingestion can result in death or serious injury. Choking, chemical burns and perforation of soft tissue may result. Severe burns can occur within 2 hours of ingestion or placement in any part of the body. Seek medical attention immediately. (13105b)

It is recommended to replace the fob battery every year.

1. See Figure 23. Press button (2) to extend key (1).
2. Turn fob over. Remove any keys or key rings attached to the loop on the fob case.
3. Separate key fob

NOTE

Do not twist screwdriver.

- a. See Figure 24. Insert blade of a 3/16-inch flathead screwdriver in the thumbnail slot (1)
 - b. Push in and up until open.
4. Remove the battery and discard.
 - a. Carefully insert the blade of a 1/8-inch flathead screwdriver under the battery (3) and lift.
 - b. Remove the battery from the battery tray.
 5. Install a new battery (CR2032) with the positive side up.
 6. Snap the cover and fob body together.
 - a. Align the positioning tabs (2) with the positioning slots (4).
 - b. Snap the fob halves together.
 - c. Make sure the fob cover is seated all the way around the fob body.
 7. Test the fob by pressing the unlock button then the lock button and verify the saddlebag locks operate.

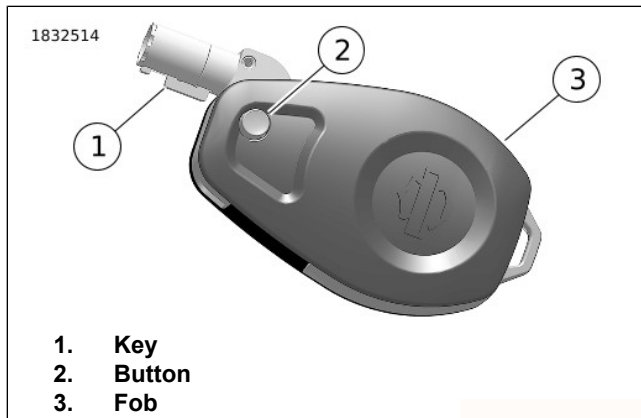

Figure 23. Key Operation

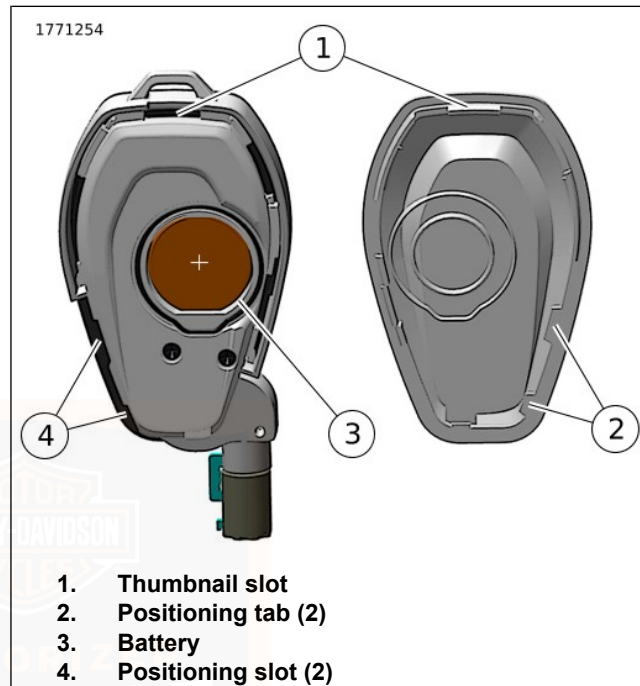

Figure 24. Fob Battery

FORK LOCK

⚠ WARNING

Do not operate vehicle with forks locked. Locking the forks restricts the vehicle's turning ability, which could result in death or serious injury. (00035a)

NOTICE

Protect your vehicle against theft. Failure to lock the motorcycle after parking could result in theft and/or equipment damage. (00151b)

See Figure 25. The fork lock is on the dash panel. Using the fork lock immediately after parking your motorcycle will discourage unauthorized use or theft. The fork lock can be locked and unlocked with the ignition key.

Locking Fork

1. Turn fork to **full left** position.
2. See Figure 25. Insert key and turn one-quarter turn counterclockwise to lock. Remove key.

Unlocking Fork

1. See Figure 25. Insert key and turn one-quarter turn clockwise to unlock. Remove key.
2. Check steering for proper operation by turning the handlebars through the full operating range. Handlebars should turn smoothly without binding.

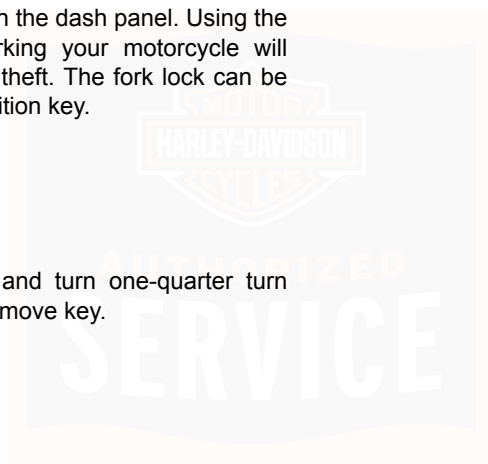

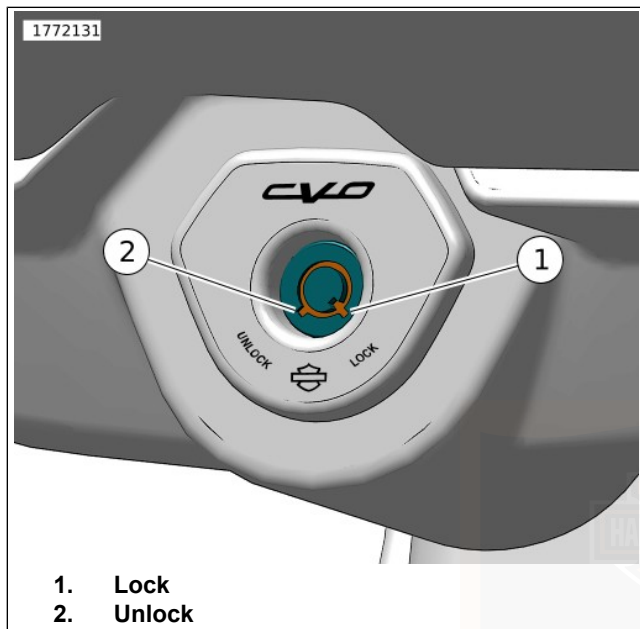

Figure 25. Fork Lock

GENERAL: CONTROLS AND INDICATORS

⚠ WARNING

Identify and understand the specific features of your vehicle. Failure to understand how these features affect the vehicle's operation can lead to an accident, which could result in death or serious injury. (00043b)

Some features explained are unique to certain models. These features may be available as accessories for your Harley-Davidson motorcycle. See a Harley-Davidson dealer for a complete list of accessories that will fit your specific motorcycle.

CONTROLS, INSTRUMENTS AND SWITCHES

Clutch Hand Lever

⚠ WARNING

Do not position fingers between hand control lever and handlebar grip. Improper hand positioning can impair control lever operation and cause loss of vehicle control, which could result in death or serious injury. (00032a)

See Figure 4. The clutch hand lever (1) is operated with the fingers of the left hand. See OPERATION > SHIFTING GEARS (Page 129).

Gear Shift Lever

See Figure 26. The gear shift lever is operated with the left foot. Neutral is found between first and second gear in the six speed shift pattern. See OPERATION > SHIFTING GEARS (Page 129).

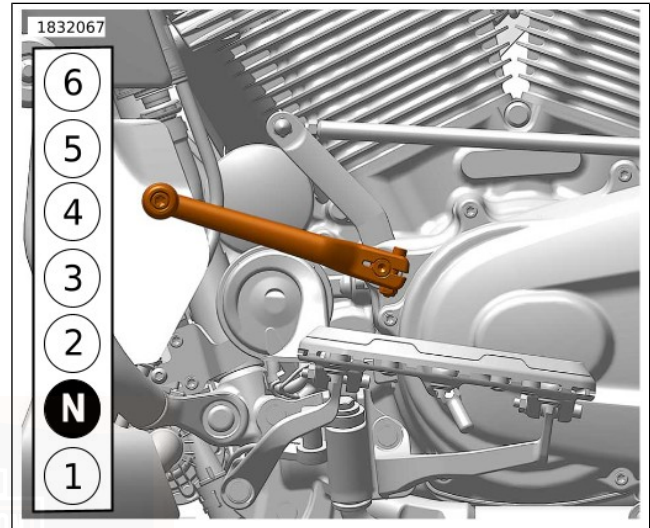

Figure 26. Gear Shift Lever and Shift Pattern

Left-Hand Control Module

See Figure 4. Operate the switches on the left hand control module (9) with the thumb of the left hand. See OPERATION > LEFT HAND CONTROL SWITCHES (Page 88).

Speedometer/Odometer

See Figure 28. The current road speed is displayed in the speedometer (4) in the IFCU display module. The accumulated mileage is displayed in the odometer (3).

Right-Hand Control Module

See Figure 4. Operate the switches on the right hand control module (7) with the thumb of the right hand. See OPERATION > RIGHT HAND CONTROL SWITCHES (Page 93).

Brakes

⚠ WARNING

Do not position fingers between hand control lever and handlebar grip. Improper hand positioning can impair control lever operation and cause loss of vehicle control, which could result in death or serious injury. (00032a)

Front brake lever: See Figure 4. The front brake lever (4) controls the front brake. Operate the hand lever with the fingers of the right hand.

Lever adjustment: See Figure 27. The distance between the brake lever and the hand grip is adjustable as follows:

- Push the brake lever slightly away from the grip to ease pressure on the brake lever adjuster.

- Rotate the brake lever adjustment thumbwheel left or right to decrease or increase distance between lever and hand grip.

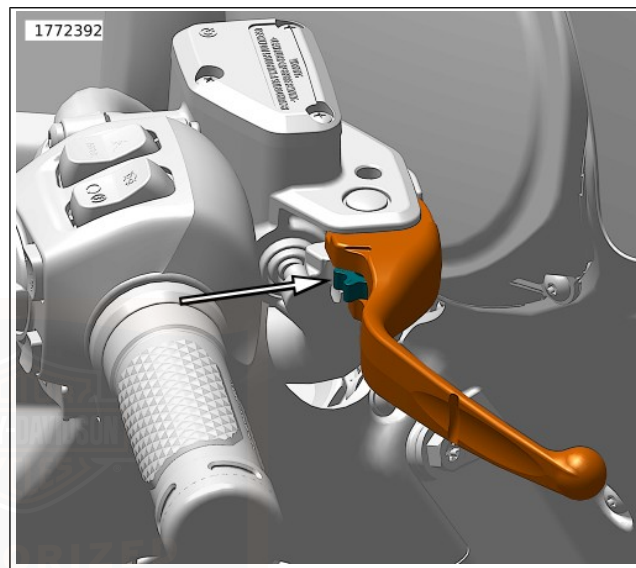

Figure 27. Front Brake Lever Adjustment Thumbwheel

Rear brake pedal: See Figure 5. The rear brake pedal (7) activates the rear wheel brake.

⚠ WARNING

Do not apply brake strongly enough to lock the wheel. A locked wheel will skid and can cause loss of vehicle control, which could result in death or serious injury. (00053a)

Apply brakes evenly to prevent wheels from locking up. A balance between rear and front brake is best.

Throttle Twist Grip

Accelerate: See Figure 4. Slowly twist throttle twist grip (5) backward (toward rear of motorcycle) to open the throttle.

Decelerate: Slowly twist throttle control grip forward (toward the front) to close the throttle.

OFF/RUN/START Switch

NOTE

The headlamp and tail lamps operate when the switch is in the RUN position.

See Figure 33. To start the engine, see OPERATION > STARTING THE ENGINE (Page 118).

INSTRUMENTS

NOTE

To prevent scratches use care when cleaning the IFCU face.

IFCU backlighting is a dimming function that activates after a slight delay.

This dimming function can be set to automatic (switches based on ambient light) and will briefly change when ambient lighting changes (such as going through a tunnel). This function can also be set to manual and the user controls the brightness of the screen.

Speedometer

⚠ WARNING

Travel at speeds appropriate for road and conditions and never travel faster than posted speed limit. Excessive speed can cause loss of vehicle control, which could result in death or serious injury. (00008a)

See Figure 28. The speedometer (4) registers forward vehicle speed in miles per hour (mph) (U.S.) and/or kilometers per hour (km/h).

Tachometer

NOTICE

See **OPERATING RECOMMENDATIONS** section. Do not operate the engine above maximum safe RPM as shown under **OPERATION** (red zone on tachometer). Lower the RPM by upshifting to a higher gear or reducing the amount of throttle. Failure to lower RPM may cause equipment damage. (00159a)

See Figure 28. The tachometer (2) measures the engine speed in revolutions per minute (rpm x 1000).

Fuel Gauge

See Figure 28. The fuel gauge (5) indicates the approximate amount of fuel in the fuel tank.

Voltmeter

See Figure 28. The voltmeter (1) indicates the measured electrical system voltage. With the engine running above 1500 rpm, the voltmeter registers 13.0-14.5 V with battery at full charge.

Odometer

See Figure 28. The odometer (3) indicates the total accumulated mileage for the motorcycle. Press the trip switch to cycle through the different widget displays.

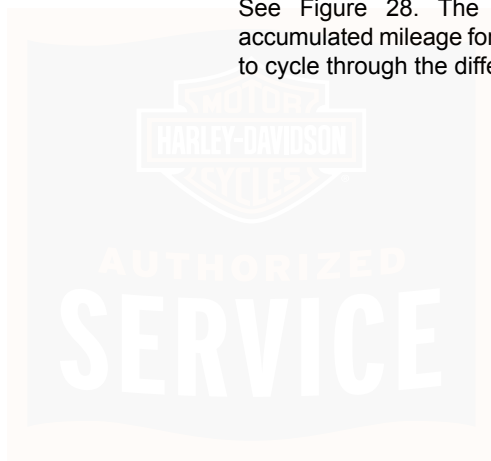

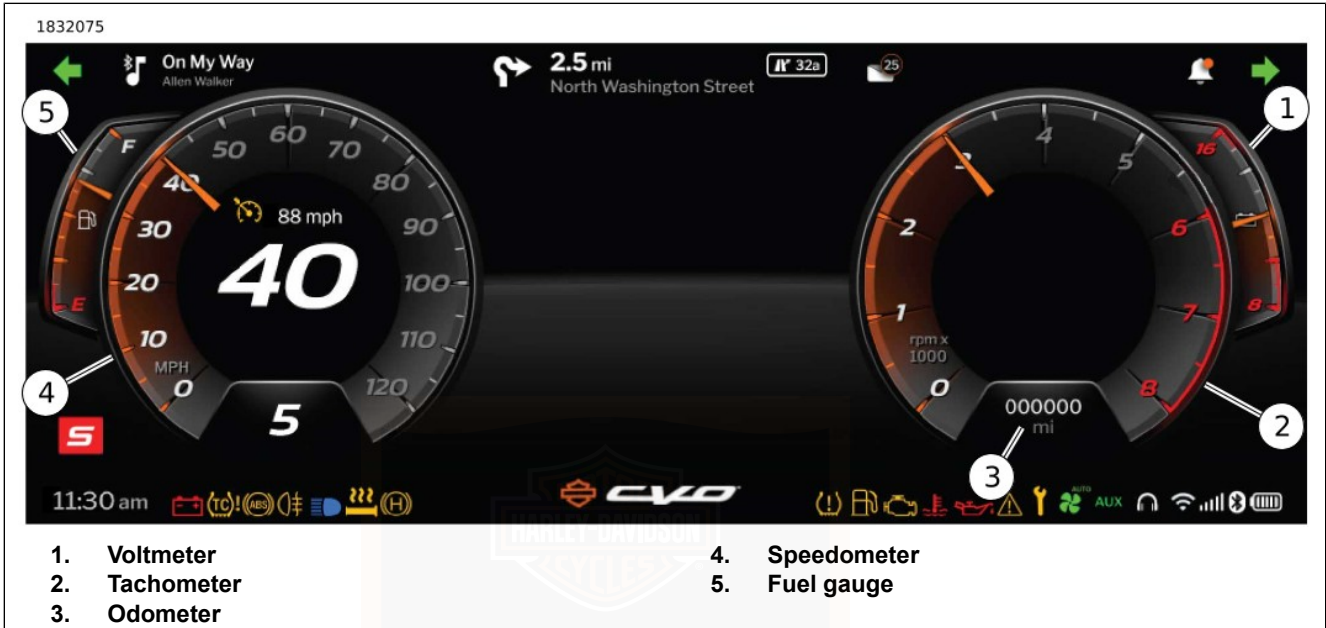

Figure 28. IFCU Instruments

SERVICE

1832296



1. Left turn signal
2. Cruise control
3. Vehicle hold control
4. Heated hand grips (not used)
5. Headlamp high beam
6. Gear indicator
7. Front fog lamps (not used)
8. ABS
9. Traction control/alert
10. Battery discharge/load shed
11. Ride mode

Figure 29. IFCU Indicators

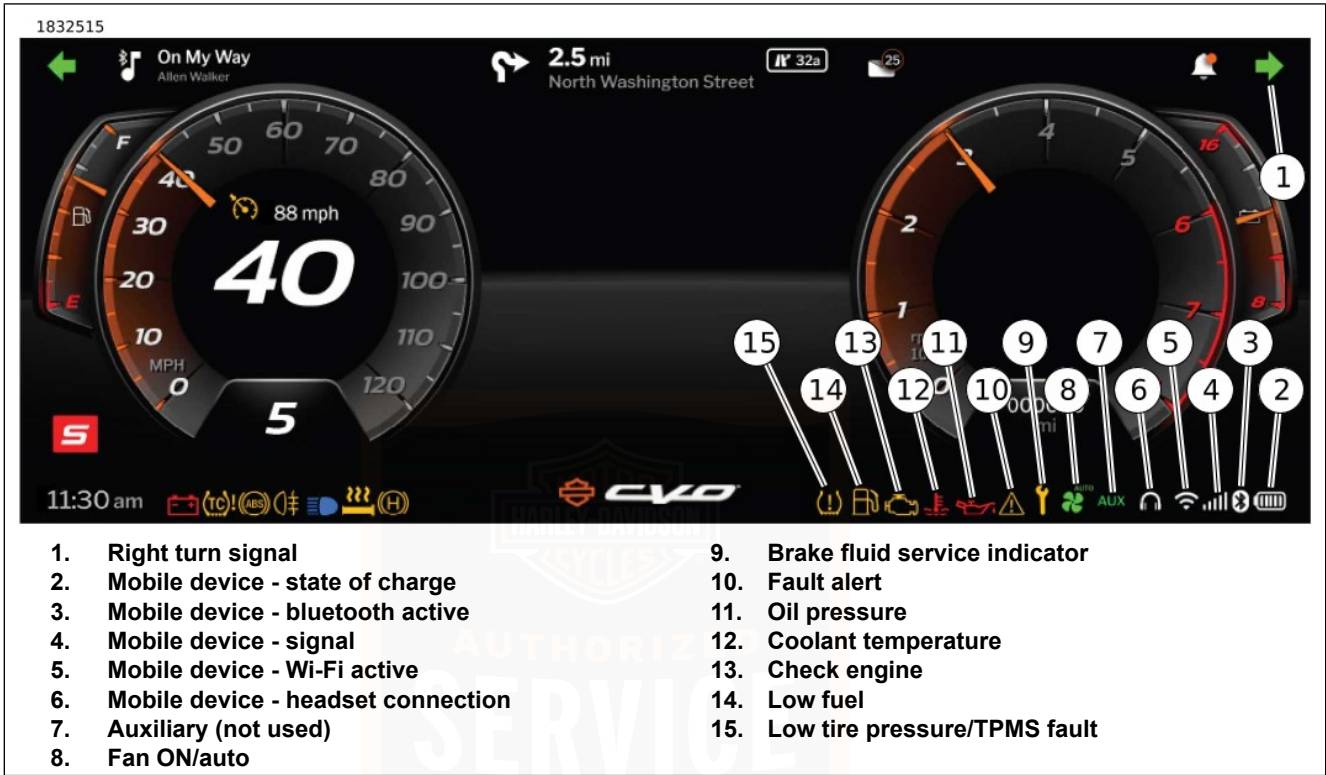

Figure 30. ICU Indicators

INDICATORS

Check Engine Lamp

See Figure 30. The check engine lamp (13) indicates the condition of the engine/engine management system.

The check engine lamp normally comes on when the motorcycle is first turned on. During this time, the engine management system runs a series of self-diagnostics.

If the check engine lamp does not turn off after starting the engine or comes on at any other time, see a Harley-Davidson dealer.

Low Fuel Lamp

Solid: See Figure 30. The low fuel warning lamp (14) indicates when the gasoline in the tank reaches the low fuel level (approximate). See SPECIFICATIONS > SPECIFICATIONS (Page 31) for the low fuel level. See OPERATION > INFOTAINMENT CONTROL UNIT (IFCU) (Page 98) for fuel range features.

Flashing: If the low fuel lamp flashes continuously or remains on after filling the fuel tank, see a Harley-Davidson dealer.

Battery Discharge/Load Shed Indicator

See Figure 29. The battery discharge indicator (10) indicates overcharging or undercharging of the battery.

The load shed indicator (amber color) turns on when accessory power to select functions has been shut off due to low battery voltage.

Function shut down will start with items listed in the partial load shed column. If the system senses a need to restrict more accessories, items in the full load shed column will be limited. Refer to Table 25.

Refer to: OPERATION > ACCESSORY CONNECTOR (Page 114).

Refer to: SERVICE PROCEDURES > BATTERY MAINTENANCE (Page 209).

Table 25. Load Shed Results

Partial Load Shed	Full Load Shed
	Data Link Connector (DLC) ⁽¹⁾ Auxiliary lamps - OFF ⁽¹⁾ Power locks - Inop ⁽¹⁾ Heated gear - Inop ⁽¹⁾ Tour pack power - Inop ⁽¹⁾
Chassis cool flow fan - OFF ⁽¹⁾	
Speaker volume limit - 30% ⁽¹⁾	Speaker volume limit - 0% ⁽¹⁾
Heated grips - OFF ⁽¹⁾	
<i>(1) If equipped</i>	

Fault Alert Indicator

See Figure 30. The fault alert indicator (10) turns on when the vehicle has detected a fault. See a Harley-Davidson dealer for service.

Turn Signal Indicators

Flashing: See Figure 29 and Figure 30. A turn signal is activated. When the 4-way hazard flashers are operating, both turn indicators flash simultaneously.

Rapid flashing: A turn signal lamp is not operating. Exercise caution and use hand signals. Replace inoperative components at earliest opportunity.

Headlamp High Beam Indicator

See Figure 29. The headlamp high beam indicator (5) is on when the high beam or flash-to-pass switch is activated.

Cruise Control Indicator

See Figure 29. The cruise control indicator (2) displays the status of the cruise control system.

Off: Cruise control is not enabled.

Orange: Cruise control is enabled. Cruising speed is not set or has been disengaged.

Green: Cruising speed is set. Vehicle speed is being maintained by the cruise control system.

Gear Indicator

See Figure 29. The currently selected gear (1-6) is displayed at the bottom of the speedometer display. The gear indicator (6) displays a green "N" when the transmission is in neutral.

ABS Lamp

See Figure 29. The ABS lamp (8) displays the status of the ABS. Refer to Table 26.

▲ WARNING

If ABS lamp continues flashing at speeds greater than 3 mph (5 km/h) or remains on continuously, the ABS is not operating. The standard brake system is operational, but wheel lock up can occur. Contact a Harley-Davidson Dealer to have ABS repaired. A locked wheel will skid and can cause loss of vehicle control, which could result in death or serious injury. (00361b)

Slow flashing: The ABS lamp begins flashing when the vehicle is turned on. The flashing lamp indicates that the system is in self-diagnostic mode. It continues to flash until motorcycle speed exceeds 3 mph (5 km/h). ABS is not operational until the lamp turns off.

▲ WARNING

Rapid flashing of the ABS lamp while the red fault indicator lamp is lit indicates a potential brake system fault. Move the motorcycle out of traffic applying both front and rear brakes to reduce speed and to stop motorcycle in a safe location. Contact a Harley-Davidson dealer for brake system repair. Operating a motorcycle with an improperly functioning brake system can adversely affect brake performance, which could result in death or serious injury. (08904a)

Rapid flashing with solid fault alert indicator: This indicates a potential brake system fault. Apply both front and rear brakes to reduce speed and to stop motorcycle. The brake controls could feel stiff when applied. If this occurs, move the motorcycle to a safe location to stop. Service is required to correct the fault before continuing to ride. See a Harley-Davidson dealer for service.

Solid: Continuous illumination of the lamp indicates an ABS fault. ABS is disabled and the brakes are operating as non-ABS brakes. See a Harley-Davidson dealer for service.

Table 26. ABS Lamp State

ABS LAMP	STATE
ABS Lamp Flashes	START-UP: ABS Lamp bulb check.
ABS Lamp OFF	NORMAL OPERATION: After vehicle speed > 3 mph (5 km/h).
ABS Lamp Continuous	ABS not functioning.
ABS Lamp Rapid Flash with Solid Red Fault Alert	Brake System Fault, Do not ride.

Oil Pressure Indicator

NOTICE

If the oil pressure indicator lamp remains lit, always check the oil supply first. If the oil supply is normal and the lamp is still lit, stop the engine at once and do not ride further until the trouble is located and the necessary repairs are made. Failure to do so may result in engine damage. (00157a)

See Figure 30. The oil pressure lamp turns on when the motorcycle is turned on. The lamp remains on until the engine is started.

If the lamp is on while the engine is running, sufficient oil is not circulating through the engine.

Check engine oil. Add oil as necessary. See MAINTENANCE AND LUBRICATION > CHECK ENGINE OIL LEVEL (Page 177). For other possible causes, see TROUBLESHOOTING > ENGINE (Page 225).

If the engine oil level is sufficient and the lamp remains on, stop the engine immediately. See a Harley-Davidson dealer for service.

Low Tire Pressure/TPMS Fault Lamp

⚠ WARNING

Be sure tires are properly inflated, balanced, undamaged, and have adequate tread. Inspect your tires regularly and see a Harley-Davidson dealer for replacements. Riding with excessively worn, unbalanced, improperly inflated, overloaded or damaged tires can lead to tire failure and adversely affect stability and handling, which could result in death or serious injury. (00014b)

See Figure 30. The low tire pressure/TPMS fault lamp (15) indicates when a low tire pressure condition or a TPMS system fault has occurred.

Flashing (60 seconds, followed by solid lamp): TPMS fault has been detected. This event can occur for a variety of reasons, including loss of signal from the sensors or sensor battery failure. Tire pressure data may not be available while the lamp is lit. See a Harley-Davidson dealer for service.

Solid: The system has detected that one or more tires have low pressure. The IFCU will also indicate details for this condition. Safely stop the vehicle and use a tire pressure gauge to check the pressure of each affected tire. Inflate the tires according to specifications in BEFORE RIDING > CHECKING TIRE PRESSURE AND INSPECTING TIRES (Page 43) or as specified on the label on the frame downtube. The lamp will turn off when you begin riding the motorcycle with the correct pressure in the tires. Also refer to BEFORE RIDING > CHECKING TIRE PRESSURE AND INSPECTING TIRES (Page 43) to compensate tire pressures for tires that have recently been ridden. If tire pressure has been adjusted per BEFORE RIDING > CHECKING TIRE PRESSURE AND INSPECTING TIRES (Page 43), readjust per tire recommendation at the earliest convenience.

NOTE

Do not use TPMS as a pressure gauge when adding or removing air from a tire. Sensor data is sent to the TPMS at varying intervals (depending on whether the vehicle is in motion, parked on the jiffy stand, or has a significant change in tire pressure). The tire pressure data may not refresh immediately when adding or removing air from the tire. Over or under-inflation can result.

See OPERATION > INFOTAINMENT CONTROL UNIT (IFCU) (Page 98) for tire pressure data displayed in the IFCU.

Traction Control/Alert Indicator

See Figure 29. The Traction Control/Alert indicator (9) displays the status of the traction control system.

Solid: Traction control has been turned off.

Slow flashing: The traction control indicator begins flashing when the vehicle is turned on. This indicates that the system is in self-diagnostic mode. It continues to flash until motorcycle speed exceeds 3 mph (5 km/h).

Rapid flashing: Traction control system active intervention.

Off: Traction control system is on.

Solid with fault alert indicator on: Indicates a traction control fault. Traction control is disabled and the motorcycle is operating as traction control turned off. See a Harley-Davidson dealer for service.

Ride Mode Indicator

See Figure 29. The ride mode indicator (11) displays the currently selected ride mode. See OPERATION > RIDE MODES (Page 109).

Vehicle Hold Control Indicator

See Figure 29. The vehicle hold control indicator (3) displays the status of the vehicle hold control system.

Solid: Vehicle Hold Control is engaged and maintaining brake pressure.

Slow Flashing: Indication that brake pressure is being released, or is about to be released automatically. The rider should be prepared to engage the brake manually or drive off. Refer to: OPERATION > CORNERING RIDER SAFETY ENHANCEMENTS (Page 123).

Mobile Device - State of Charge

See Figure 30. The state of charge indicator (2) displays the connected mobile device's battery level.

Mobile Device - Bluetooth Active

See Figure 30. The Bluetooth active indicator (3) displays the connection status of a wireless device. When connected to a device, the indicator will be white. When no connection is detected, the indicator will be gray.

Mobile Device - Signal

See Figure 30. The signal indicator (4) displays the signal strength of a Bluetooth connected device.

Mobile Device - Wi-Fi active

See Figure 30. The Wi-Fi active indicator (5) displays the Wi-Fi status of a connected device.

Mobile Device - headset connection

See Figure 30. The headset connection indicator (6) displays the connection status of the headset. When connected, the indicator is white. When no connection is detected, the indicator is gray.

Fan ON/Auto Indicator

See Figure 30. If equipped, the fan ON/auto lamp (8) indicates the status of the accessory cooling fan: always OFF, ON when ignition is ON, or auto ON (turns on when engine coolant temperature reaches a preset level).

Brake Fluid Service Indicator

See Figure 30. The brake fluid service Indicator (9) turns on when the vehicle has detected that it requires an ABS bleed procedure to be performed. See a Harley-Davidson dealer for service.

Coolant Temperature Indicator

▲ WARNING

Do not loosen or remove pressure cap when cooling system is hot. The cooling system is under pressure and hot coolant and steam can escape from pressure cap, which could cause severe burns. Allow motorcycle to cool before servicing the cooling system. (00091c)

NOTICE

If the engine coolant temperature indicator lamp remains lit, always check the coolant level. If the coolant level is normal and the lamp is still lit, stop the engine at once and do not ride further until the trouble is located and the necessary repairs are made. Failure to do so may result in engine damage. (00158a)

See Figure 30. The coolant temperature indicator (12) turns on when the coolant has exceeded threshold temperature. If coolant level is sufficient and the indicator remains on, see a Harley-Davidson dealer for service.

LEFT HAND CONTROL SWITCHES

Trip Switch

See Figure 32. **Vehicle off:** Press the trip switch (4) to display the accumulated mileage in the odometer display in the IFCU.

Vehicle in accessory/ignition mode: Press the trip switch to cycle through the widget displays.

Headlamp

High beam: See Figure 31. Push the headlamp switch up (2) to activate the high beam. The (blue) high beam indicator in the IFCU is lit when the high beam is on. Refer to Table 27.

Low beam: Press the headlamp switch down (1) to activate the low beam.

Flash-to-pass: When the headlamp low beam is on, press and release the headlamp switch (flash-to-pass) (3) to flash the high beam before passing another vehicle. The high beam indicator lamp in the IFCU is illuminated as long as the headlamp switch is pressed.

When in accessory mode, press the headlamp (flash-to-pass) switch to activate the headlamp. Refer to Table 27.

Cruise Control Switch Assembly

See Figure 32. The CRUISE/SET/RESUME switch assembly (2, 3, 15) automatically regulates the speed of the vehicle. See OPERATION > CRUISE CONTROL (Page 111) for detailed operation. Refer to Table 27.

CRUISE: Press the CRUISE OFF/ON button (3) to enable cruise control. The cruise control indicator in the IFCU lights orange. Pressing the CRUISE OFF/ON button again turns off cruise control, and the cruise control indicator turns off.

SET/-: With cruise control enabled, press SET/- (15) to set the cruising speed. The cruise control indicator in the IFCU lights green. While at cruising speed, press SET/- to decrease the regulated speed. Tapping SET/- decreases the speed by 1 mph (1.6 km/h). Holding SET/- down gradually decreases cruise speed.

RES/+: If cruise control is disengaged (such as a braking event), press RES/+ (2) to resume the previous cruising speed. While at cruising speed, press RES/+ to increase speed. Tapping RES/+ increases the speed by 1 mph (1.6 km/h). Holding RES/+ down gradually increases cruise speed.

Left Turn Signal

Activate: See Figure 32. Press the left turn signal switch (11) to activate the left turn signal. Refer to Table 27.

Cancel (manual operation): If activated, press the left turn signal switch to cancel the left turn signal.

Cancel (automatic operation): If activated, the turn signal lamps automatically cancel when a full turn has been detected based on speed, acceleration and turn completion.

The lamps also cancel if the turn signal has been activated for a prolonged period while the motorcycle speed is greater than 7 mph (11 km/h). If the motorcycle is stopped or moving slower than this speed, the turn signal continues flashing.

NOTE

Front turn signal lamps also function as running lamps. This feature may not be available in all markets.

Horn

See Figure 32. Press the horn switch (10) to operate the horn. The horn can be activated for up to 10 seconds at a time. If the horn switch is held for a longer period, the horn automatically deactivates. Refer to Table 27.

Traction Control Switch

See Figure 32. The traction control switch (5) activates and deactivates the traction control system. Refer to Table 27.

Disable: Press switch for 1 second with engine running and vehicle stopped.

Enable: Press switch at anytime to resume traction control operation.

NOTE

Traction control last active mode is automatically enabled at each ignition start cycle and when enabled.

Navigate UP/DOWN/RIGHT/LEFT Switches

See Figure 32. The UP/DOWN/RIGHT/LEFT four-way switch set (6, 9, 7, 13) operates radio or media file features on equipped vehicles.

OK/Enter Button

See Figure 32. Press the OK/Enter button (8) to approve or enter the currently highlighted section on the IFCU screen.

Back

See Figure 32. Press the Back button (12) to return to the previous IFCU menu or function.

Main Menu/Bike Function

See Figure 32. Press and release the Main Menu/Bike Button (14): Cycle through the IFCU menus.

Long press: Display the IFCU Bike Function menu.

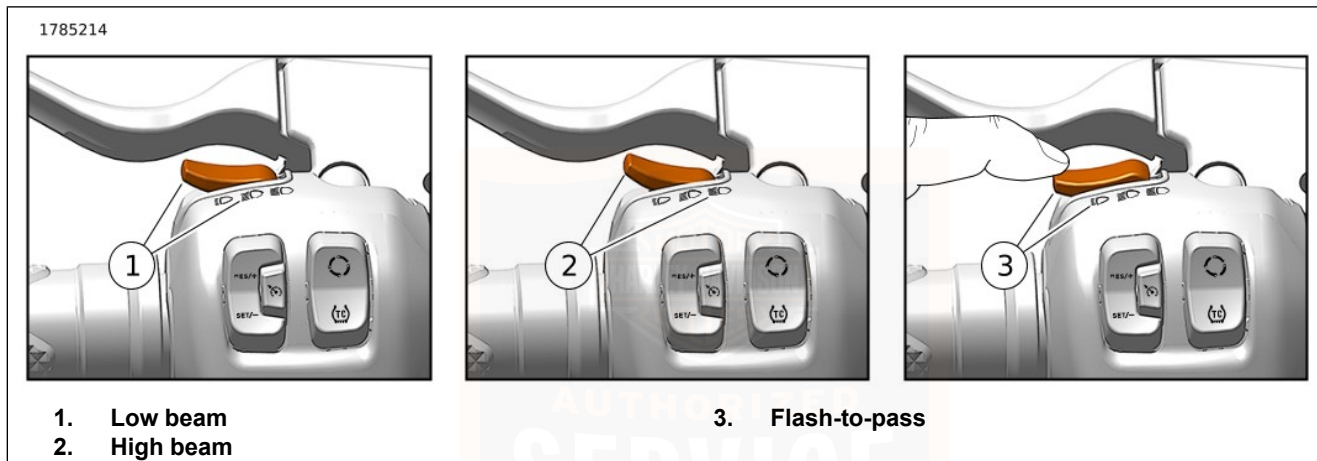
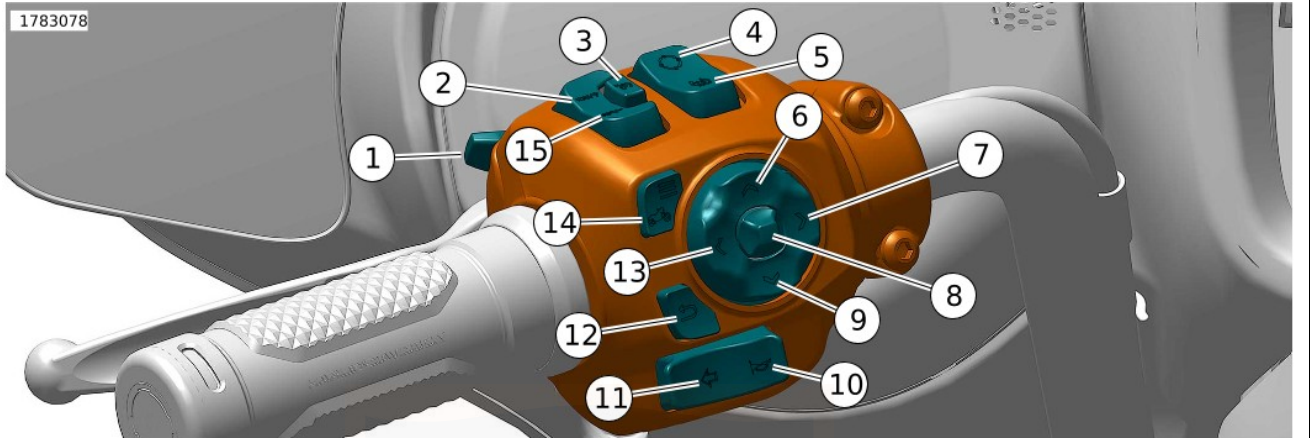

Figure 31. Headlamp Switch

1783078



- | | |
|---|---|
| 1. Headlamp | 9. Navigate down |
| 2. Cruise control RES/+ (resume/increase speed) | 10. Horn |
| 3. Cruise control OFF/ON | 11. Left turn signal |
| 4. Trip | 12. Back |
| 5. Traction control | 13. Navigate left |
| 6. Navigate up | 14. Main menu/Bike function |
| 7. Navigate right | 15. Cruise control SET/- (set/decrease speed) |
| 8. OK/enter | |

Figure 32. Left Hand Control Module (LHCM)

Table 27. Left-Hand Control Switches





SWITCH	NAME	FUNCTION
	Flash-to-pass	Press and release to flash the high beam. In ACC, press to activate the headlamp.
	Low beam	Press down to switch the headlamp to low beam.
	High beam	Press up to switch the headlamp to high beam.
	Cruise control ON/OFF	Press to turn cruise control ON or OFF.
SET/-	Cruise control set/decrease speed	Press to set cruise control speed.
RES/+	Cruise control resume/ increase speed	Press to resume to a set cruise control speed.

Table 27. Left-Hand Control Switches









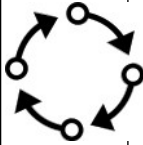

SWITCH	NAME	FUNCTION
	Trip	Press to display odometer or alternate widgets.
	Traction control	Press to activate and deactivate traction control.
	Horn	Press to sound the horn.
	Left turn	Press to signal a left turn.
	Navigate left	Press to go left on the IFCU screen.
	Navigate up	Press to go up on the IFCU screen.

Table 27. Left-Hand Control Switches

SWITCH	NAME	FUNCTION
	Navigate right	Press to go right on the IFCU screen.
	Navigate down	Press to go down on the IFCU screen.
	Menu	Press to navigate through the menus in the IFCU.
	Back	Press to return to the previous IFCU menu or function.
	Bike Function	Press to navigate to the Bike Function menu.

RIGHT HAND CONTROL SWITCHES

Hazard Warning 4-Way Flasher

See Figure 33. The hazard warning switch (2) is used to leave a stranded motorcycle in the 4-way flashing mode. With the flashers, the motorcycle can be left with the ignition off until assistance is found. Refer to Table 28.

1. With the OFF/RUN/START switch in the RUN (3) position, press the hazard warning switch to activate the 4-way flashers.

NOTE

- *The fob must be present when turning on the 4-way flashers and when canceling the flashers.*
 - *The four-way flashers will operate when the vehicle is tipped over regardless of OFF/RUN/START switch position. See OPERATION > STARTING AFTER TIPOVER (Page 120).*
2. Turn OFF/RUN/START switch to OFF (4). The 4-way flashers continue for 2 hours or until cancelled by the rider.
 3. To cancel, turn the OFF/RUN/START switch to RUN. Press the hazard warning switch.

OFF

See Figure 33. Press the engine OFF/RUN/START switch to OFF (4) to shut off the engine. Refer to Table 28.

RUN

See Figure 33. Push the engine OFF/RUN/START switch to RUN (3) to enable engine start and run. The engine OFF/RUN/START switch must be in the RUN position to start or operate the engine. Refer to Table 28.

Right Turn Signal

Activate:

See Figure 33. Press the right turn signal switch (9) to activate the right turn signal. Refer to Table 28.

Cancel (manual operation): If activated, press the right turn signal switch to cancel the right turn signal.

Cancel (automatic operation): The turn signal lamps automatically cancel when a full turn has been detected based on speed, acceleration and turn completion.

The lamps also cancel if the turn signal has been activated for a prolonged period (20 flashes) while the motorcycle speed is greater than 7 mph (11 km/h). If the motorcycle is stopped or moving slower than this speed, the turn signal continues flashing.

NOTE

Front turn signal lamps also function as running lamps. This feature may not be available in all markets.

Volume Up

See Figure 33. Press the volume up (1) button to increase volume. Refer to Table 28.

Next

See Figure 33. Press the next button (7) to select the next media file. Refer to Table 28.

Volume Down

See Figure 33. Press the volume down (11) button to decrease volume. Refer to Table 28.

Previous

See Figure 33. Press the previous button (12) to select the previous media file. Refer to Table 28.

Play/Pause

See Figure 33. Press the play/pause button (13) to play or pause the current media file. Refer to Table 28.

Push-to-Talk

See Figure 33. The Push-To-Talk (PTT) switch (6) is used to operate the rider/passenger intercom on equipped vehicles. Refer to Table 28.

Start

1. See Figure 33. Switch the OFF/RUN/START switch to RUN (3). Shift the transmission to neutral. The neutral (green) indicator illuminates. See OPERATION > STARTING THE ENGINE (Page 118).
2. Press the OFF/RUN/START switch to START (5) to operate the starter motor. Refer to Table 28.

NOTE

- *When the starter is activated, the headlamp is momentarily turned off to reduce battery load.*
- *If the engine does not start, the starter motor runs for ten seconds and stops. Release the start switch. Press the start switch to try again. After several unsuccessful attempts to start the engine, see a Harley-Davidson dealer.*

Voice Recognition

See Figure 33. The voice recognition switch (8) activates the voice recognition features on a connected mobile device. Refer to Table 28.

Using natural language processing allows a larger range of phrase requests that are more natural to each user.

Mode

See Figure 33. Press the mode button (10) to change the ride mode. See OPERATION > RIDE MODES (Page 109). Refer to Table 28.

NOTE

Last active mode is automatically enabled at each ignition start cycle and when enabled.

SERVICES

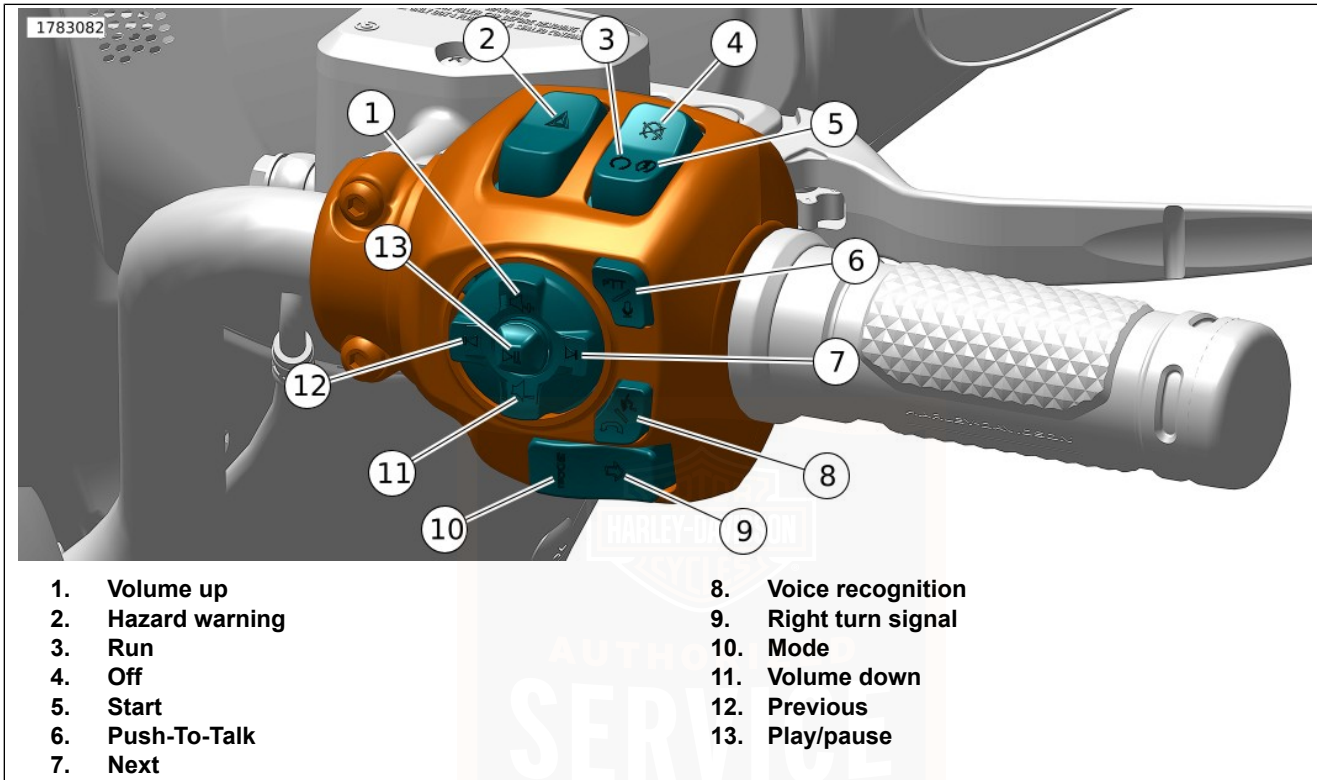

Figure 33. Right Hand Control Module (RHCM)

Table 28. Right Hand Control Switches







SWITCH	NAME	FUNCTION
	Hazard	Press to activate the 4-way flashers.
	Run	Press to allow the engine to start and run.
	Start	Press to start the engine.
	Off	Press to stop the engine or to prevent the engine from starting.
	Push-To-Talk	Press and hold to activate talk function.
	Voice recognition	Initiates a voice recognition session.

Table 28. Right Hand Control Switches







SWITCH	NAME	FUNCTION
	Volume up	Press to increase volume.
	Volume down	Press to decrease volume.
	Next	Press to select the next media file.
	Previous	Press to select the previous media file.

Table 28. Right Hand Control Switches

SWITCH	NAME	FUNCTION
	Play/pause	Press to play or pause the current media file.
	Mode	Press to change the ride mode.

INFOTAINMENT CONTROL UNIT (IFCU)

▲ WARNING

Set volume levels and other controls on audio and electronic devices before riding. Distractions can lead to loss of control, resulting in death or serious injury. (00088b)

▲ WARNING

Do not select a volume level that blocks out traffic noise or interrupts the concentration necessary for safe operation of the motorcycle. Distractions or a volume level that blocks out traffic noise could cause loss of control resulting in death or serious injury. (00539b)

NOTICE

There are no serviceable parts inside the unit; leave all servicing to qualified service personnel. Disassembly of the unit could result in equipment damage and/or equipment malfunction. (00172a)

NOTE

To make full use of features and minimize distraction while on the road, configure the system with your personal preferences before riding. Refer to: OWNER MANUAL > INFOTAINMENT CONTROL UNIT (IFCU) OPERATION (Page 139).

For additional information, see INFOTAINMENT CONTROL UNIT (IFCU) OPERATION > HELP (Page 158).

The IFCU is a multi-function touch screen display that provides vehicle instrumentation, navigation, and infotainment functions. The display is customizable for rider preferences. Refer to: OWNER MANUAL > INFOTAINMENT CONTROL UNIT (IFCU) OPERATION (Page 139).

Controls

The IFCU can be controlled using the left and right hand controls and also as a touch screen display. See OPERATION > LEFT HAND CONTROL SWITCHES (Page 88), and

OPERATION > RIGHT HAND CONTROL SWITCHES
(Page 93).

NOTE

Touch screen function is limited while vehicle is in motion.

Main Menu

See Figure 32 and Figure 34. To access the main menu press the main menu/bike function button (14) on the Left Hand Control Module (LHCM) or by pressing the main menu selection on the touch screen. Use the navigation buttons on the LHCM to navigate up (6), right (7), down (9), left (13), OK/enter (8) and back (12), or touch screen to navigate through the menu selections. Refer to Table 29.

Some of the menus shown will contain multiple levels to customize the display and interaction experience. Before riding, take some time to get acquainted with these menus, and the various settings, to optimize the experience. Refer to: OWNER MANUAL > INFOTAINMENT CONTROL UNIT (IFCU) OPERATION (Page 139).



Figure 34. On Screen Main Menu Selection

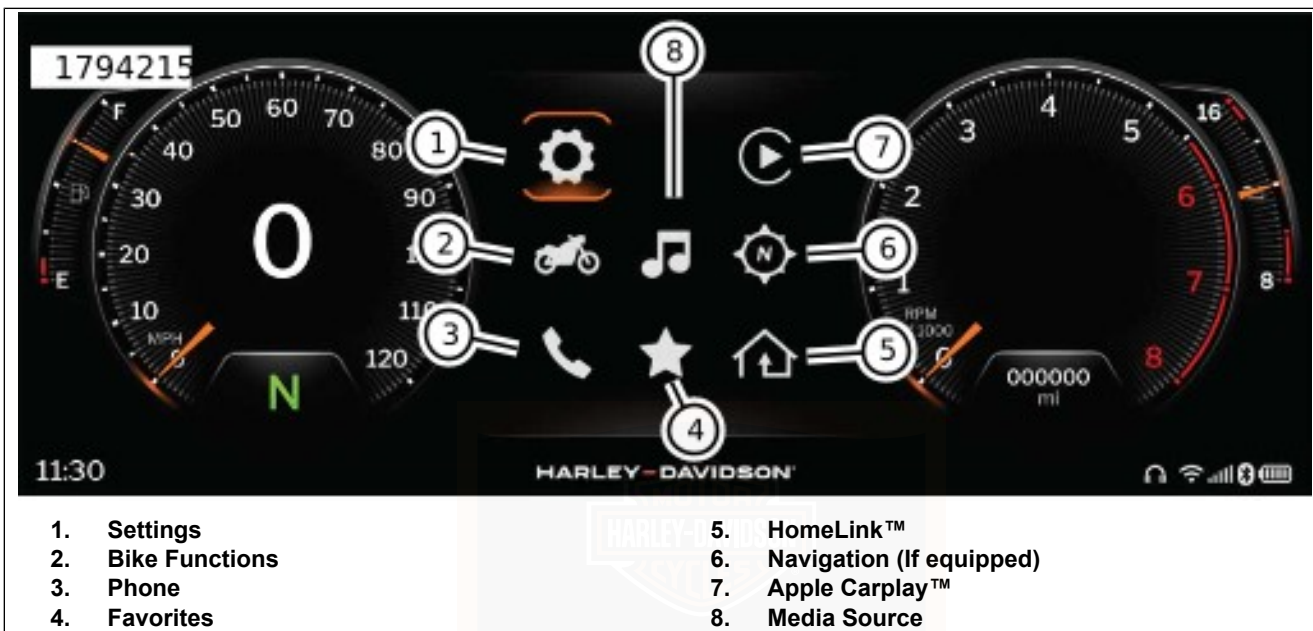

Figure 35. IFCU Menu Selections

Table 29. IFCU

Press	Result
1. [Settings]	<ul style="list-style-type: none">• Displays setting categories available.• Available selections (if equipped): Bluetooth, Sound, Display, System, Ride Modes, Tuner, Phone, Wi-Fi.
2. [Bike]	<ul style="list-style-type: none">• Displays available vehicle settings (will vary based on available equipment).• Available selections: Fog Light, Fan Control, Audio on/off, Heated Grips, Power Locks.
3. [Phone]	<ul style="list-style-type: none">• Displays phone and call information.• Available selections: Phone Screens, Phone Interactions, Outgoing Call, Incoming Call.
4. [Favorites]	<ul style="list-style-type: none">• Displays favorites for several categories.• Available selections: Global Favorites, Media Favorites, Tuner Favorites, Phone Favorites.
5. [HomeLink™]	<ul style="list-style-type: none">• Display available devices to control.• Available selections: Garage Door.
6. [Navigation]	<ul style="list-style-type: none">• Display current location navigation information.• Available selections: Routes, Route Options, Menu, Search.

Table 29. IFCU

Press	Result
7. [Apple Carplay™]	<ul style="list-style-type: none">• Displays available options (if equipped).• Available selections: Apple Carplay™ main menu.
8. [Media Source]	<ul style="list-style-type: none">• Displays available media sources.• Available selections: Radio Bands, Blue Tooth, Apple Carplay™, USB input.

Status Bar Notifications

The status bar is located at the top of the IFCU display and will show notifications and information for audio, navigation and connected mobile devices when those functions are running in the background.



Figure 36. Status Bar Notifications

Widgets

Widgets are small displays that allow the rider to display additional information on the IFCU. Use the trip switch to cycle

widgets. OPERATION > LEFT HAND CONTROL SWITCHES (Page 88)

See Figure 37. **Trip:** The trip A and B widget displays trip mileage, trip duration, trip average fuel mileage, and trip average speed.

See Figure 38. **Playlist:** The Playlist widget (1) displays the current playlist information from a connected device. This information includes song title and artist name.

TPMS: The Tire Pressure Monitoring System (TPMS) widget (2) displays tire pressure data for front and rear tire. Top number displayed for front and rear tires is the actual read tire pressure. Target indicates the systems desired tire pressure based on environmental conditions.

Ride Info: The Ride Info widget (3) displays ambient temperature, date, average fuel mileage and coolant temperature.

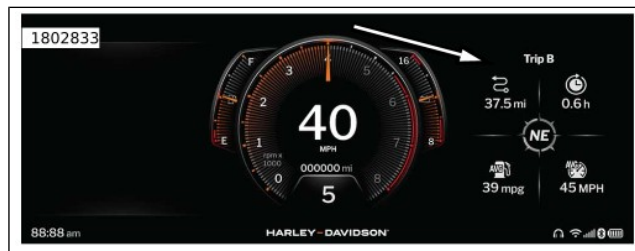

Figure 37. Navigation Widget

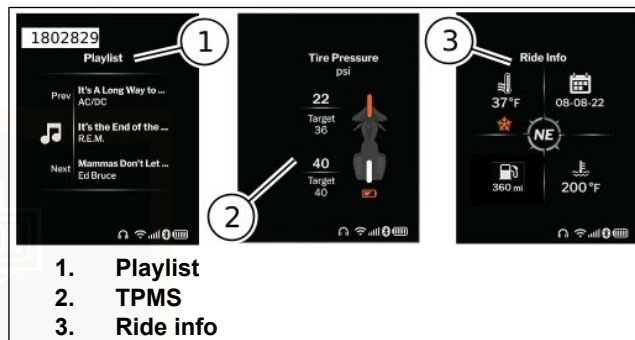

Figure 38. Widget Options

IFCU Layout

See Figure 39, Figure 40 or Figure 41. The IFCU can be configured to display one of three different layouts optimized for different riding situations and styles.

See Figure 42. All versions can be configured in high contrast mode.

- **Cruiser:** This is the default layout. Traditional instruments displayed on left and right side with space for additional menus and information to be displayed in the center.
- **Sport:** Layout optimized for a clean focused appearance. Instruments combined in center as a single item.
- **Tour:** Layout optimized for longer rides using navigation. Basic Instruments displayed on the left side with the center available for navigation display and additional information displayed on the right.

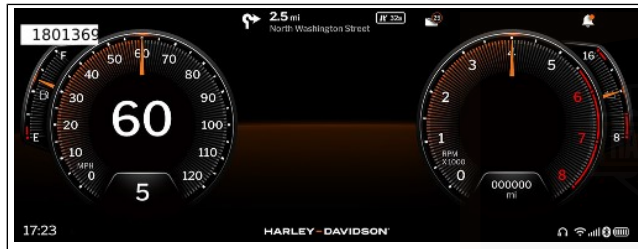

Figure 39. Cruiser



Figure 40. Sport

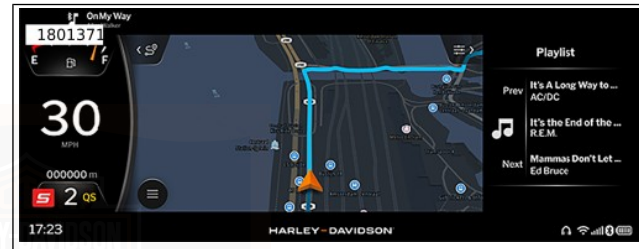

Figure 41. Tour

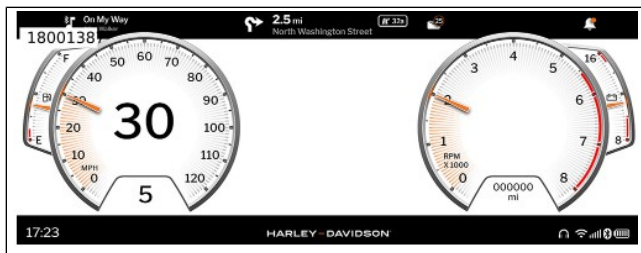

Figure 42. High Contrast

Basic Audio Operation

See Figure 33. Use the Right Hand Control Module (RHCM) buttons to navigate volume up (1), volume down (11), next (7), previous (12), play/pause (13) on the RHCM to adjust audio media settings. See OWNER MANUAL > INFOTAINMENT CONTROL UNIT (IFCU) OPERATION (Page 139).

Alert messages

See Figure 43. If a warning or alert becomes necessary, it is displayed on the IFCU as a pop up message.



Figure 43. Side Stand Down Message

Side Stand Down Warning Message

This motorcycle has a jiffy stand interlock feature. Refer to: BEFORE RIDING > OPERATING JIFFY STAND (Page 49).

See Figure 43. If the jiffy stand is lowered while the motorcycle is in gear or while riding, a Side Stand Down alert message appears on the IFCU display.

Clearing message (before starting motorcycle): Place transmission in neutral or raise jiffy stand.

Clearing message (while riding): Safely bring the motorcycle to a stop. Raise jiffy stand.

Clearing message (temporarily): Press the trip switch. The message clears momentarily before displaying again.

Fuel Range Alerts

Low Fuel Range: The Low Fuel Range alert is automatically displayed when the low fuel indicator is on. See Figure 44. The Low Fuel Range alert shows the approximate mileage available with the amount of fuel left in the fuel tank. The range display is only updated when the vehicle is moving.

Low Range: See Figure 45. The Low Range alert is displayed when the fuel range drops to 10 miles or 10 kilometers. The motorcycle is nearly out of fuel. Refuel as soon as possible. See OWNER MANUAL > SPECIFICATIONS (Page 31).

Turn Off Automatic Low Fuel Pop-up: With the fuel range displayed, hold the trip switch down until the fuel range flashes two times. To turn this feature back on, hold the trip switch down until the fuel range flashes once.

Reset: Resetting the low fuel warning indicator and fuel range requires sufficient fuel in the tank and an ignition cycle change (RUN-OFF-RUN).



Figure 44. Low Fuel Range Alert



Figure 45. Low Range Alert

Adding at least 2 USgal (7.6 L) of fuel allows the fuel range to update. The fuel range slowly updates over the next 30 mi (48 km) after refueling.

Battery Reconnection and Initialization: If the battery is disconnected and reconnected, the gauge requires approximately a half tank of fuel to initialize fuel range functionality.

Bike Tipped Warning

⚠ WARNING

If tip occurs, check all controls for proper operation. Restricted control movement can adversely affect the performance of the brakes, clutch or ability to shift, which could result in loss of vehicle control and death or serious injury. (00350a)

See Figure 46. If the motorcycle is tipped over, a warning appears on the IFCU and the four-way flashers will operate. The engine cannot start until the tip condition is reset. Refer to: OPERATION > STARTING AFTER TIPOVER (Page 120). to reset.

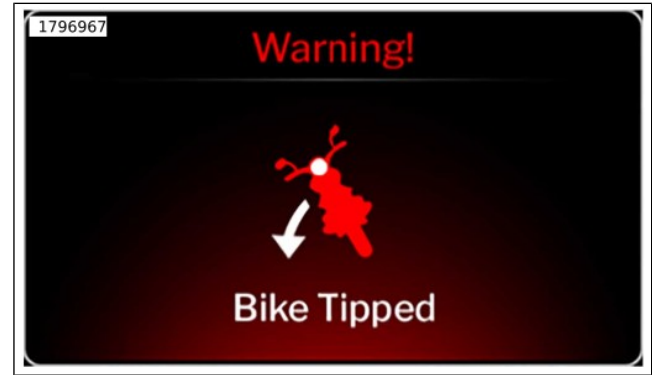

Figure 46. Tip Over Warning

Fob Missing Alert

See Figure 47. If the motorcycle is driven away without the fob, the Key Fob Missing alert will appear on the IFCU display.

Without the fob, the motorcycle can only be started with a manual PIN entry to disarm the security system. Refer to: SECURITY SYSTEM > PERSONAL IDENTIFICATION NUMBER (PIN) (Page 61). The alert can be cleared by touching "Ok" on the IFCU display or by bringing the fob within range of the motorcycle.



Figure 47. Fob Missing Message

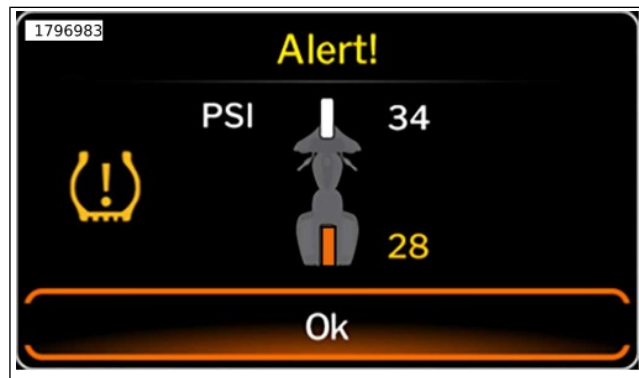

Figure 48. Tire Pressure Message

Tire Pressure Alert

See Figure 48. If a tire pressure becomes low, an alert will appear on the IFCU display. Safely bring the motorcycle to a stop. Check and adjust the tire pressure(s). See BEFORE RIDING > CHECKING TIRE PRESSURE AND INSPECTING TIRES (Page 43).

Low Temperature Alert

See Figure 49. If the ambient temperature drops below a preset temperature threshold, an alert will appear on the IFCU display. Touch "Ok" and the message will disappear.



Figure 49. Low Temperature Message

Electronic Labels

See Figure 50. Navigate to **Settings > General Settings > System Info > E-Labels**. Select E-Labels to display applicable Certification and regulatory information.

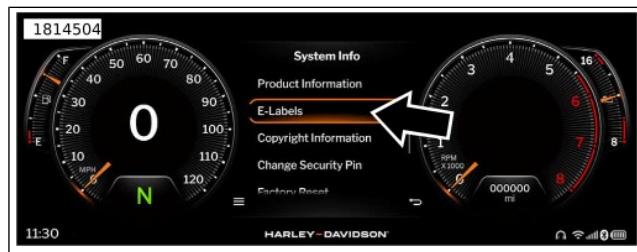

Figure 50. Electronic Labels

RIDE MODES

Ride Modes

Refer to Table 30. The ride mode icon displays the currently selected ride mode. The selected ride mode can be changed using the mode button on the RHCM. Refer to: OPERATION > RIGHT HAND CONTROL SWITCHES (Page 93).

Road: Delivers balanced performance with an intuitive blend of technology for daily use, with ABS and Traction Control System (TCS) intervention that offers peace of mind.

Rain: This mode offers restrained acceleration and limited engine braking with higher levels of ABS and traction control intervention to give the rider greater confidence when riding in the rain or when traction is otherwise limited. The Rain Mode is also an appropriate setting for riders to build confidence as they become familiar with the motorcycle.

Sport: Delivers the full performance potential of the motorcycle in a direct and precise manner, with full power and the quickest throttle response on tap. Traction control is set to its lowest level of intervention intended/appropriate for on-road use, and engine braking is increased. Sport Mode maximizes the rider connection to the motorcycle for a direct and visceral performance riding experience.

Track: This mode retains the same peak power as Sport mode, but with a track-tuned throttle response for more refined control. The ABS setting has a track-tuned reduced level of intervention and disables rear-to-front electronically linked braking. Traction control system retains the same performance as Sport mode. This mode is intended for use on a dry track / closed course.

Track +: This mode retains the same peak power as Sport mode and the same track-tuned throttle response as Track mode. The ABS setting has an even further reduced level of intervention which permits a significantly higher level of rear wheel slip under braking or aggressive downshifts to further enhance rider control in a track setting. Additionally, this mode disables electronically linked braking in both directions (front-to-rear and rear-to-front) providing fully independent control of both brakes. Traction control system performance is also track-tuned and permits more wheel slip during both straight-line acceleration and cornering. This mode should only be used by experienced riders and on a dry track / closed course.

Custom Ride Modes: Custom Modes allow the rider to select their own preference of engine torque delivery characteristics, engine braking, Throttle Response, TCS and ABS within specific ranges.





NOTE

Custom ride modes must be set up before they can be used. Refer to: INFOTAINMENT CONTROL UNIT (IFCU) OPERATION > SYSTEM SETTINGS (Page 139).

Table 30. Ride Modes

ICON	Ride Mode
	Road
	Rain
	Sport
	Track
	Track +

Table 30. Ride Modes

ICON	Ride Mode
	Custom track
	Custom track +
	Custom A
	Custom B
	Ride mode fault

Ride Mode Fault

Displays when system fault is detected by vehicle. When fault is detected, cycle ignition.

1. With security fob present, set the OFF/RUN switch to OFF.
2. Wait 45 seconds.
3. Set the OFF/RUN switch to ON.

If cycling ignition system does not eliminate fault, see a Harley-Davidson dealer for service.

CRUISE CONTROL

⚠ WARNING

Do not use the cruise control system in heavy traffic, on roads with sharp or blind curves or on slippery roads of any kind. Using the cruise control in these circumstances can cause loss of control, which could result in death or serious injury. (00083a)

⚠ WARNING

Travel at speeds appropriate for road and conditions and never travel faster than posted speed limit. Excessive speed can cause loss of vehicle control, which could result in death or serious injury. (00008a)

Turn Cruise On

NOTE

Cruise control operates when:

- At least 10 seconds have lapsed since the engine was started.
- Vehicle speed is between 25–90 mph (40–145 km/h) in second or higher gear.

See Figure 51. Press the CRUISE switch to turn on cruise (1). When on, the cruise icon in the speedometer face glows amber.

Set Cruise Speed

See Figure 51. When the motorcycle reaches your intended speed, press the SET/- switch to set the cruise speed (2). The amber cruise icon changes to green and will display set speed.

If necessary, adjust the cruise speed to match the speed limit or traffic conditions:

Increase/Decrease Cruise

Tapping the RES/+ switch increases speed by 1 mph (1.6 km/h). Holding the switch down gradually increases cruise speed.

Tapping the SET/- switch decreases speed by 1 mph (1.6 km/h). Holding the switch down gradually decreases cruise speed.

Disengage Cruise

See Figure 51. To drop out of cruise speed, roll the throttle closed through the roll-off switch (3).

Cruise also disengages when the rider:

- Squeezes the front brake lever or presses the rear brake pedal.
- Squeezes the clutch lever.
- Rolls the throttle open more than 10 mph (16 km/h) above the set speed.

Resume Cruise

NOTE

If the current speed is more than 15 mph (24 km/h) below the cruise speed, cruise will not resume.

See Figure 51. If cruise has been disengaged yet the cruise indicator is amber, pressing the RES/+ switch resumes cruise (4). The icon glows green. The motorcycle automatically resumes cruise at the set speed.

Turn Cruise Off

Press the CRUISE switch to turn off cruise control. The cruise icon goes blank.

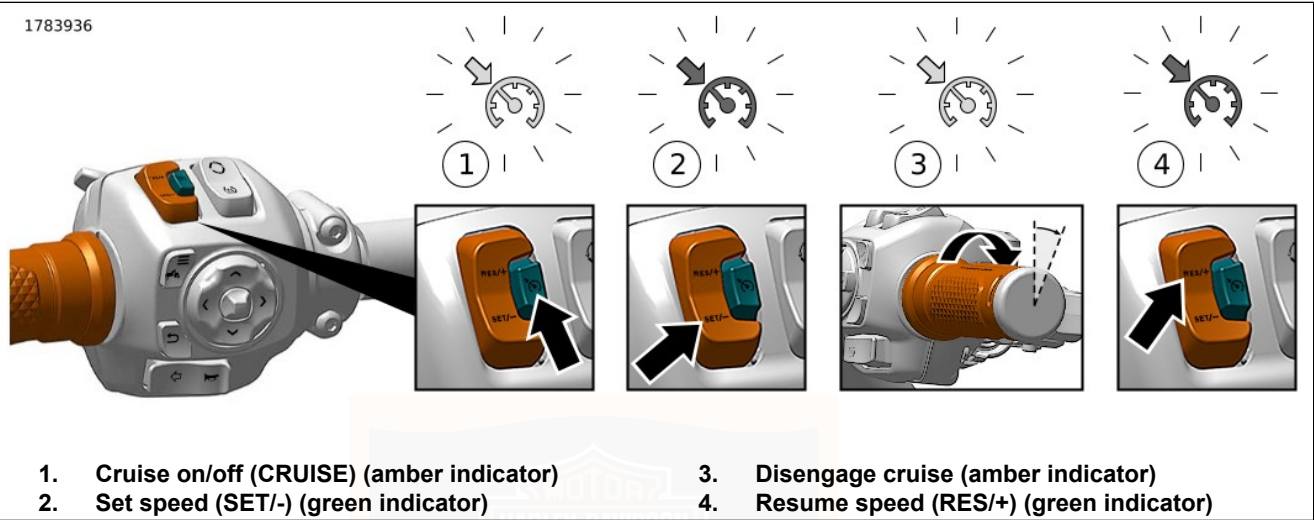

Figure 51. Cruise Control (typical)

ELECTRONIC THROTTLE CONTROL (ETC)

This motorcycle has an Electronic Throttle Control (ETC). Instead of using a mechanical cable connection to the throttle body, this technology uses redundant grip sensors to indicate rider requested throttle position to the Electronic Control Module (ECM). The ECM then regulates proper fuel/air intake and ignition timing based on the rider's actions.

The Electronic Control Module (ECM) monitors the status of the grip sensors, throttle plate actuation and airflow. If Trouble Codes are detected, the ECM disables cruise control, illuminates the check engine lamp and will transition to one of the following modes.

ETC Limited Performance Mode

The rider experiences near-normal operation. The motorcycle operates with provisions to guard against unintended acceleration.

ETC Power Management Mode

The throttle plate actuator returns to an "idle detent" or "limp-home" position, which provides enough torque to achieve speed of about 25 mph (40 km/h). The motorcycle's response to grip sensor input is reduced.

ETC Forced Idle Mode

The throttle plate actuator is forced to a "fast idle" position, which provides enough torque to crawl, but not enough torque to operate at traffic speeds.

ETC Forced Shut Down Mode

The engine is forced to shut down.

ACCESSORY CONNECTOR

NOTICE

It is possible to overload the vehicle's charging system by adding too many electrical accessories. If the combined electrical accessories operating at any one time consume more electrical current than the vehicle's charging system can produce, the electrical consumption can discharge the battery and cause damage to the vehicle's electrical system. (00211d)

See Figure 52. An accessory connector is under the seat. See a Harley-Davidson dealer or www.harley-davidson.com for suitable electrical accessories.

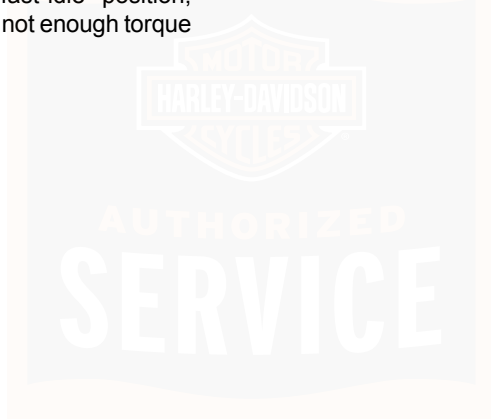

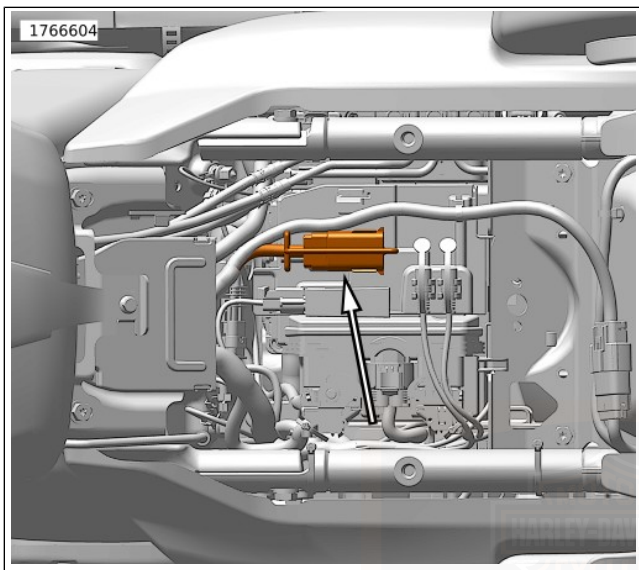

Figure 52. Accessory Connector (under seat)

HEADSET CONNECTION

This model incorporates wireless Bluetooth headset operation. Refer to: INFOTAINMENT CONTROL UNIT (IFCU) OPERATION > SYSTEM SETTINGS (Page 139).

MEDIA COMPARTMENT

Compartment

⚠ WARNING



Improper loading of cargo or installation of accessories can affect motorcycle stability and handling, which could result in death or serious injury.

- **Keep cargo weight concentrated close to the motorcycle and as low as possible to minimize the change in the motorcycle's center of gravity.**
- **Distribute weight evenly on both sides of the vehicle.**
- **Do not load bulky items too far behind the rider or add weight to the handlebars or front forks.**
- **Do not exceed maximum load capacity stated on the label for bags, luggage, and racks, if equipped. Combined load of luggage rack and Tour-Pak must not exceed load capacity on the label within the Tour-Pak.**
- **Do not exceed the maximum load capacity stated within the media compartment, when indicated and if equipped.**
- **Check that cargo is secure. The cargo cannot shift while riding. Periodically recheck load.**
- **Close and lock luggage before riding or leaving the vehicle unattended.**
- **Accessories that change the operator's riding position may increase reaction time and affect handling of the motorcycle.**

- **Items with large surface areas, such as fairings, windshields, backrests and luggage racks (if equipped) can adversely affect stability and handling.**

(14717c)

See Figure 53. The media compartment on the right side of the fairing has a Universal Serial Bus Type-C (USB-C) port to connect with a phone, media device or USB-C drive. The USB-C port is powered and operational when the motorcycle is turned on or in accessory mode. An interface cable may be needed to connect with certain devices.

Open: Push down to release latch, Door is spring loaded to open. Pull up on the front of the compartment door.

Close: Push the door shut until latch is engaged.

Install USB or media device: Figure 53 Connect device to the USB-C port. Rest device in compartment. Close the compartment door.

Keep door closed while riding to prevent items from falling out. Remove valuable items from the media compartment before leaving the vehicle unattended.

Devices

NOTE

Do **not** use media players with hard drives. Vibration may cause damage to device.

Not all media devices or media file types are compatible with the IFCU.

Connected devices may be used for the following purposes.

Phone: Charges the phone and plays media files from the phone. However, phone calling and text messaging features are achieved only through Bluetooth connection.

Media device: Charges the device and plays media files.

USB drive: Plays media files, imports/exports navigation files and loads software updates.

Memory card: Some types of memory cards can be connected to play media files. Connection requires an adapter or reader.

The radio continues to play while devices are added or removed. However, when importing/exporting files or installing updates to the radio, do not disconnect the USB device until the task has completed.

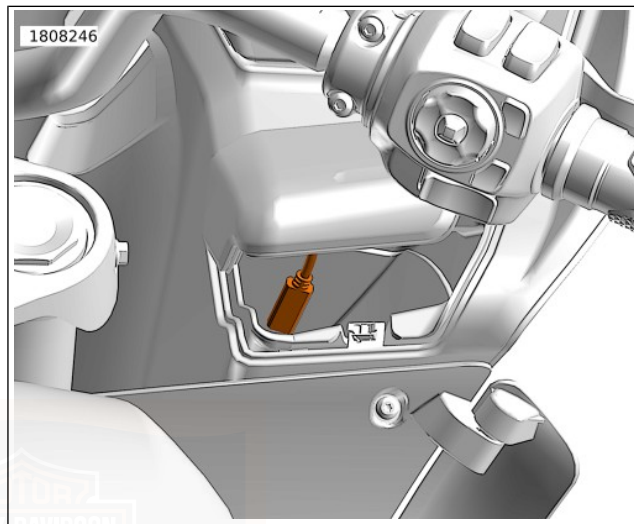

Figure 53. Media Compartment with USB Port

STARTING THE ENGINE

General

NOTICE

The engine should be allowed to run slowly for 15-30 seconds. This will allow the engine to warm up and let oil reach all surfaces needing lubrication. Failure to comply can result in engine damage. (00563b)

Rolling the throttle before starting the motorcycle is unnecessary.

Starting

▲ WARNING

Shift transmission to neutral before starting engine to prevent accidental movement, which could result in death or serious injury. (00044a)

NOTE

See Figure 30. The check engine lamp (13) will light when the ignition is turned on. You will hear the fuel pump run for a short time as it pressurizes the fuel system.

1. See Figure 54. With the security system fob present, press the OFF/RUN/START switch to RUN (4). Do not roll the throttle.
2. Rotate fork lock fully into the unlocked position.
3. Apply the brake to prevent movement of the motorcycle.
4. Squeeze the clutch lever in against the handgrip. Shift transmission to neutral.
5. Press and release the START (3) button to start the motorcycle.

NOTE

To allow enhanced lubrication of the engine before startup, the engine will crank a number of turns before starting.

6. When the engine has started, you can operate your motorcycle as you normally would after raising the jiffy stand.

NOTE

See Figure 29. The ABS indicator lamp (8) will remain flashing until vehicle is moving approximately 3 mph (5 km/h).

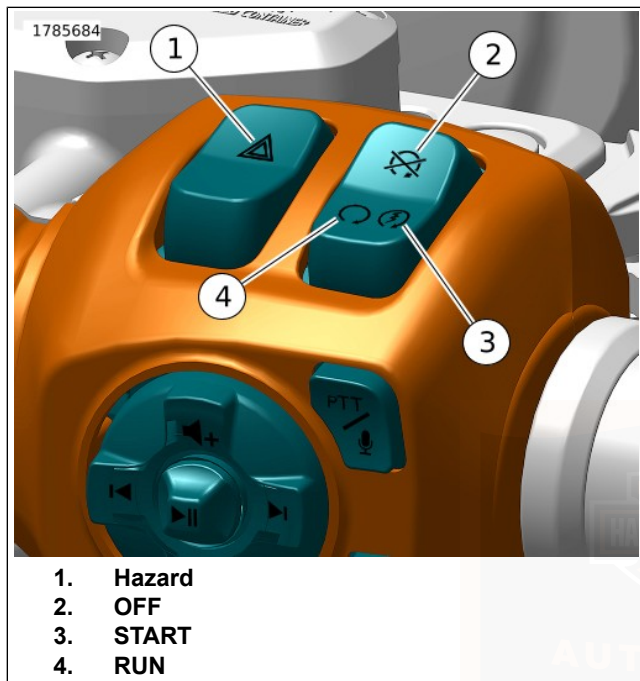

Figure 54. RHCM: OFF/RUN/START and Hazard Buttons

STARTING AFTER TIPOVER

▲ WARNING

If tip occurs, check all controls for proper operation. Restricted control movement can adversely affect the performance of the brakes, clutch or ability to shift, which could result in loss of vehicle control and death or serious injury. (00350a)

NOTE

- If the motorcycle is tipped over, the TIP pop-up warning appears in the IFCU and four-way flashers activate.
- The engine cannot start until the tip condition is reset.
- The ignition must be reset to turn four-way flashers off.

1. Set motorcycle upright.
2. See Figure 54. Set the OFF/RUN/START switch to OFF (2).
3. Wait.
Duration: 45 seconds
4. Set the OFF/RUN/START switch to RUN (4).
5. Press the hazard switch (1) to turn four-way flashers off.

ENGINE IDLE TEMPERATURE MANAGEMENT SYSTEM (EITMS)

The Engine Idle Temperature Management System (EITMS) can provide limited cooling of the rear cylinder for riders who frequently find themselves in prolonged idle conditions or traffic congestion. Riders can enable or disable EITMS to complement their riding style.

Operation

- If EITMS is active, releasing the clutch lever to the clutch engagement zone will deactivate EITMS and begin firing the rear cylinder. While the vehicle is stopped, the rider may benefit from twisting the throttle/raising engine speed slightly just before riding away, which will deactivate EITMS and begin firing the rear cylinder immediately regardless of clutch lever position.
- The engine warm idle speed is 850 rpm, but the idle speed can vary depending on other factors including electrical load on the vehicle. When EITMS is active on this engine, the idle speed will increase to 950–1,000 rpm until EITMS is deactivated.

Activation

NOTE

EITMS will not operate within the first 30 seconds after starting the engine.

EITMS will turn off the rear cylinder fuel injector **when all of the following preset parameters are met:**

- Throttle position is at idle
- Motorcycle speed is under 1.2 mph (2 km/h)
- Engine speed is under 1,200 rpm
- Engine Temperature (ET) sensor input reading is above preset level
- Ambient Air Temperature (AAT) sensor reading is above preset level

Deactivation

EITMS will deactivate and the rear cylinder fuel injector will resume operation **if any one of the following conditions occur:**

- AAT sensor reading drops below preset levels
- ET sensor reading drops below preset level
- Throttle position is above idle (rider rolls throttle)
- Motorcycle speed exceeds 1.9 mph (3 km/h)
- Engine speed exceeds 1,350 rpm
- The clutch is released with the motorcycle in gear

Enabling / Disabling EITMS

NOTE

- *EITMS can be enabled or disabled with the engine running or shut off.*
- *On vehicles equipped with radios, the EITMS activation and enabled / disabled can be viewed in the Information Screen.*

Enabled: The EITMS engine cooling feature automatically activates whenever the vehicle comes to a complete stop and is idling during elevated temperature conditions. When the feature is enabled, it may not activate under cool riding conditions.

Disabled: The EITMS feature is not active under any conditions.

EITMS can be enabled or disabled by performing the following procedure.

1. See Figure 54. Set the engine OFF/RUN/START switch to RUN.
2. Push the throttle to roll-off position and hold.
3. See Figure 29. After 3 seconds, the cruise control indicator lamp (2) will flash indicating the EITMS status.
 - Flashing green indicates EITMS is enabled.

- Flashing amber indicates that EITMS is disabled.

4. Repeat the procedure to enable or disable EITMS.

NOTE

- *A flashing cruise lamp indicates the EITMS setting. A solid (non-flashing) lamp indicates the cruise control setting.*
- *The EITMS setting remains in effect until it is changed by the rider or dealer. There is no need to reconfigure EITMS at each startup.*

STOPPING THE ENGINE

1. See Figure 54. Push the OFF/RUN/START switch to OFF (2).
2. Remove assigned fob from range.

NOTE

If the engine stalls or stops for any reason, push the OFF/RUN/START switch to OFF to prevent battery discharge.

CORNERING RIDER SAFETY ENHANCEMENTS

Front Brake Lever

⚠ WARNING

Do not position fingers between hand control lever and handlebar grip. Improper hand positioning can impair control lever operation and cause loss of vehicle control, which could result in death or serious injury. (00032a)

See Figure 55. The front brake hand lever (1) controls the front wheel brake. The lever is on the right handlebar. Operate the hand lever with the fingers of the right hand.

Rear Brake Pedal

See Figure 55. The rear brake pedal (2) controls the rear wheel brake. The pedal is on the right side. Operate the rear brake pedal with the right foot.

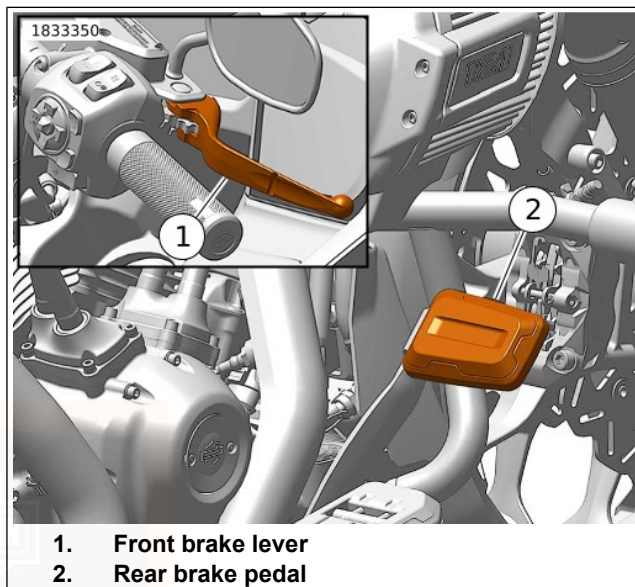

Figure 55. Brake Controls

ABS and Cornering Enhanced ABS (C-ABS) Functions

ABS is designed to prevent the wheels from locking under braking and helps the rider maintain control when braking in a straight-line, urgent situation. ABS operates independently on front and rear brakes to keep the wheels rolling and prevent

uncontrolled wheel lock. The Cornering Enhanced Antilock Braking System (C-ABS) is a variant of ABS that takes into consideration the lean angle of the motorcycle. While cornering, the available grip for braking is reduced and C-ABS automatically compensates for this reality.

Models equipped with C-ABS have a traction control button and a traction control indicator that lights when power is turned on, see OPERATION > LEFT HAND CONTROL SWITCHES (Page 88) and OPERATION > INSTRUMENTS (Page 77).

How ABS Works

The rider recognizes ABS and C-ABS activation by the slight pulsing sensation in the hand lever or the rear brake pedal. A clicking sound from the ABS module can also be heard. Both are the result of normal operation. Refer to Table 31.

For additional ABS information visit www.harley-davidson.com.

Cornering Enhanced Electronic Linked Braking (C-ELB)

The C-ELB system provides balanced front and rear braking under a wide variety of brake applications. The system provides more linking when the rider is applying heavier braking and reduces or eliminates linking for light braking and low speeds. When linked, applying the front brake lever alone will cause the system to also dynamically apply an amount of braking to the rear. C-ELB takes into account the motorcycle

lean angle and will alter the proportioning of brake pressure between the front and rear brakes while cornering in an attempt to improve the ability of the bike to maintain the rider's intended path.

How To Use ABS

While an advantage in emergency braking, ABS is not a substitute for safe riding. The safest way to stop a motorcycle is using both brakes.

During an emergency stopping situation, maintain pressure on the brakes through all ABS events. Do not modulate or "pump" the brake controls. The wheels do not lock until the end of the stop when motorcycle speed slows to a rate at which ABS is no longer needed.

Vehicle Hold Control (VHC)

Vehicle Hold Control (VHC) uses brake pressure to keep the motorcycle from rolling when it is stopped on an incline, making it easier to ride away when starting on an incline, such as a hill, a bridge or a parking ramp. The VHC holds brake pressure when activated and prevents the motorcycle from moving after the rider has released the brake controls. The system holds brake pressure until the rider actuates the throttle and clutch to pull away.

NOTE

VHC is not intended to be used as a parking brake.

NOTE

If equipped with jiffy stand switch: Motorcycle can be put into Neutral and clutch lever released.

If not equipped with jiffy stand switch: Clutch lever will need to remain pulled in.

Activation: The rider activates VHC by applying extra pressure to either the front brake hand lever or the rear brake foot control after the motorcycle has come to a complete stop. If rider brakes very hard to a stop, and holds the brake pressure after stopped, VHC may also set without any added squeeze. A VHC indicator will illuminate to confirm that the rider has activated VHC and the ABS system will hold brake pressure after the rider releases the brake control.

NOTE

When a requirement for activation is not met, VHC lamp will flash fast.

Deactivation: VHC is deactivated automatically as the rider begins to pull away from a stop, or if the rider firmly applies and releases either brake control. VHC may deactivate if rider aggressively revs the engine with clutch lever pulled in. VHC will also deactivate if the rider lowers the side stand on models with a side stand sensor (not in all markets) or shifts into neutral on models without a side stand sensor. VHC will deactivate when engine stops running. VHC will deactivate

after between approximately 3 minutes and 5 minutes. In most situations, the indicator will flash and the VHC will release if there is no rider action. (VHC may deactivate in less than five minutes to prevent overheating if being used often on steep grades.)

Limitations: VHC may not be able to hold the vehicle at a stop under all circumstances. Steep hills, road surfaces and other factors can all affect VHC capability. The rider must remain prepared to control the vehicle should it roll.

Tire Pressure Monitoring System (TPMS)

TPMS alerts the rider to low tire air pressure. Maintaining proper tire air pressure is important both for safety and for tire life. The TPMS displays current front and rear tire pressure on the IFCU and displays an indicator to alert the rider when tire pressure is low, and the pressure should be checked.

ABS: Tires and Wheels

Motorcycles equipped with ABS must always use Harley-Davidson tires and wheels. The ABS monitors the rotational speed of the wheels through individual wheel speed sensors. Changing to different diameter wheels or different size tires can alter the rotational speed. Different-sized wheels and tires can upset the calibration of the ABS and have an adverse effect on its ability to detect and prevent uncontrolled wheel lockups. Operating at tire pressures other than those

pressures specified can reduce ABS braking performance. Refer to OWNER MANUAL > SPECIFICATIONS (Page 31).

Table 31. ABS Symptoms and Conditions

SYMPTOM	CONDITION
ABS indicator continuously lit	ABS fault detected. See a Harley-Davidson dealer for service.
ABS indicator slow flashing	This indicates a normal self-diagnostics process when the motorcycle is first turned on and the speed is under 3 mph (5 km/h). ABS is not operational until the lamp turns off. If the lamp continues flashing at speeds greater than 3 mph (5 km/h), see a Harley-Davidson dealer for service.
ABS indicator rapid flashing and solid fault indicator lamp	This indicates a potential brake system fault. Apply both front and rear brakes to reduce speed and to stop motorcycle. The brake controls could feel stiff when applied. If this occurs, move the motorcycle to a safe location to stop. Service is required to correct the fault before continuing to ride. See a Harley-Davidson dealer for service.
Pulsing brake lever or pedal during an ABS event	Normal condition.
Clicking sound during an ABS event	Normal condition.
"Surge" sensation while braking	Normal condition. This is most noticeable when braking with one brake (front only or rear only). Result of a reduction in deceleration which can be caused by cracks or bumps in road, engine braking (high engine RPMs causing the rear wheel to slow down), hard braking at slow speeds, and other conditions. This is due to ABS modulating caliper brake pressure to prevent uncontrolled wheel lock.
Temporarily stiff rear brake pedal	Normal condition. Engine braking (high engine RPMs causing the rear wheel to slow down) or down shifting can activate ABS. If applying the rear brake at the same time or immediately after, the ABS may be closing a valve to prevent pressure to the rear brake. This is due to ABS modulating caliper brake pressure to prevent uncontrolled wheel lock.
Tire chirp	Normal condition. Depending on surface, tire can chirp without locking the wheel.

Table 31. ABS Symptoms and Conditions

SYMPTOM	CONDITION
Black mark on pavement	Normal condition. Depending on surface, tire can leave a black mark without locking the wheel.
Wheel lock at low speed	Normal condition. ABS does not activate on front wheel below 3 mph (5 km/h) or on rear wheel below 5 mph (8 km/h).

TRACTION CONTROL

Traction Control System

While an advantage in certain situations, traction control is not a substitute for safe riding.

Harley-Davidson's cornering traction control system can detect when the drive wheel loses traction. In wet or slippery conditions, or under abrupt acceleration, the traction-control system will limit torque to the drive wheel during loss of traction.

By reducing tire spin, the Traction Control System will aid the riders ability to maintain control while still allowing for appropriate vehicle acceleration.

The vehicle is also equipped with a Drag Torque Slip Control System to help maintain control under deceleration. When you deliver an abrupt reduction in acceleration to the vehicle, during early downshifts, or when the powertrain decelerates

on wet or slippery surfaces, the vehicle may experience rear wheel slip.

How Traction Control Works

The cornering enhanced traction control system constantly monitors the vehicles lateral acceleration when going straight and during turns, and will adjust torque delivered to the drive wheel based on detected lean angle and/or tire slip.

This adjustment is designed to limit wheel spin and help the rider maintain the desired course of travel in corners.

During start up, the traction-control lamp flashes simultaneously with the ABS lamp, this indicates that both systems are waiting for the vehicle to complete a wheel speed sensor check. The traction control system is operational after startup even during the wheel speed sensor check. The traction control lamp should turn off when the sensor check is complete.

If the drag torque slip control system senses rear wheel slip under powertrain deceleration, it may decrease drag torque,

by increasing engine Revolutions Per Minute (rpm), to limit the slip and aid the rider's ability to maintain control.

How To Use Traction Control

NOTE

When running a vehicle on a dynamometer it is advised that traction control be disabled to prevent intervention based on tire speed differences front to rear.

Traction control is automatically enabled at each ignition start cycle. The rider may choose to disable traction control anytime the vehicle is at a complete stop and the engine is running by pressing and holding the traction control switch for one full second.

The rider may find it beneficial to disengage traction control in low speed low traction situations such as, riding in deep sand, riding uphill on wet grass, or similar situations. The

traction control indicator will illuminate and remain illuminated to indicate traction control is disabled. However, if the TC indicator remains on in conjunction with the fault indicator, it means the traction control system has faulted. If this occurs see an authorized Harley-Davidson dealer.

During some fault conditions Traction Control will be enabled with degraded function and cannot be disabled.

The rider may again enable traction control at any time during vehicle operation by pressing and releasing the Traction control switch.

If the traction control indicator begins fast-blinking while riding, it means the traction-control system is intervening.

Intervention of the Drag Torque Slip Control is indicated by fast-blinking of the traction control indicator. However, disabling your Traction Control will not disable Drag Torque Slip Control.

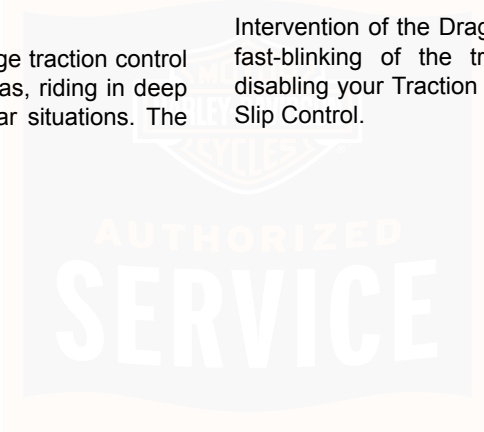

Table 32. Traction Control Symptoms and Conditions

SYMPTOM	CONDITION
Traction control indicator off	Traction control system active.
Traction control indicator continuously lit	Traction control system deactivated by user.
Traction control indicator and fault indicator continuously lit	Traction control system faulted.
Traction control indicator flashing	Normal condition. Traction control intervention.
Reduction of throttle response during a traction control event	Normal condition. Traction control intervention.
"Surge" sensation while decelerating	Normal condition. Drag torque slip control intervention.

SHIFTING GEARS

NOTICE

The clutch must be fully disengaged before attempting a gear shift. Failure to fully disengage the clutch can result in equipment damage. (00182a)

Stopped, Engine Off

Slowly pull clutch hand lever in against handlebar grip to fully disengage clutch. Gears do not engage because the transmission shafts are not turning and shifter components are not lined up. Rock the motorcycle backward and forward while lightly pressing the shift lever.

Starting from a Stop

NOTE

Always start the engine with the transmission in neutral. Always start forward motion in first gear.

1. With the engine running and the jiffy stand retracted, pull the clutch hand lever against the handlebar grip to disengage the clutch.
2. Press the gear shift lever down to the end of its travel and release. The transmission is now in first gear.
3. Ease out the clutch lever and at the same time, gradually open the throttle.

Upshift (Acceleration)

See Figure 56. Engage the next higher gear when the motorcycle reaches the shifting speed. Refer to Table 33.

Table 33. Recommended Upshift Speeds

GEAR CHANGE	mph	km/h
First to second	15	25
Second to third	25	40
Third to fourth	35	55
Fourth to fifth	45	70
Fifth to sixth	55	85

1. Close the throttle.
2. Slowly pull clutch hand lever in against handlebar grip to fully disengage clutch.
3. Lift the gear shift lever up to the end of its travel and release.
4. Ease out the clutch lever and gradually open the throttle.
5. Repeat the previous steps to engage remaining gears.

NOTE

- Disengage the clutch completely before each gear change.
- Partially open the throttle so the engine does not drag when the clutch lever is released.

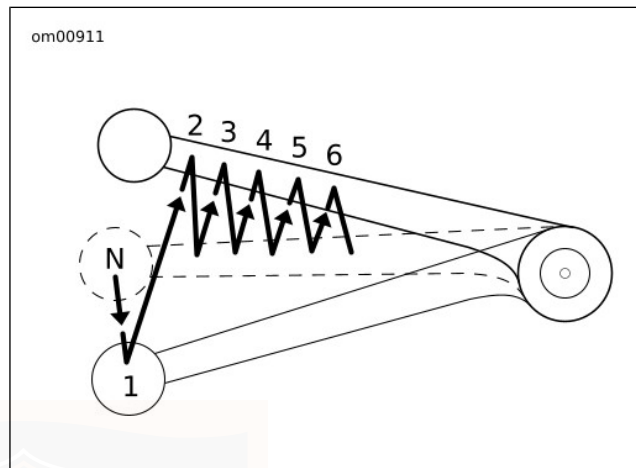

Figure 56. Shifting Sequence: Upshift

Downshift (Deceleration)

⚠ WARNING

Do not downshift at speeds higher than those listed. Shifting to lower gears when speed is too high can cause the rear wheel to lose traction and lead to loss of vehicle control, which could result in death or serious injury. (00045b)

See Figure 57. When speed decreases, as when climbing a hill or slowing for a turn, shift to the next lower gear. Refer to Table 34.

Table 34. Recommended Downshift Speeds

GEAR CHANGE	mph	km/h
Sixth to fifth	50	80
Fifth to fourth	40	65
Fourth to third	30	50
Third to second	20	30
Second to first	10	15

NOTE

The shifting points shown in the table are recommendations. Individual shifting points can differ from the table.

1. Close the throttle.
2. Slowly pull clutch hand lever in against handlebar grip to fully disengage clutch.
3. Press the gear shift lever down to the end of its travel and release.
4. Ease out the clutch lever and gradually open the throttle.
5. Repeat the previous steps to engage remaining gears.

NOTE

- *Disengage the clutch completely before each gear change.*

- *Partially open the throttle so the engine does not drag when clutch lever is released.*

NOTICE

Shift to neutral before stopping engine. Shifting mechanism can be damaged by shifting gears while engine is stopped. (00183a)

The gear shifter mechanism permits shifting the transmission to neutral from either first or second gear.

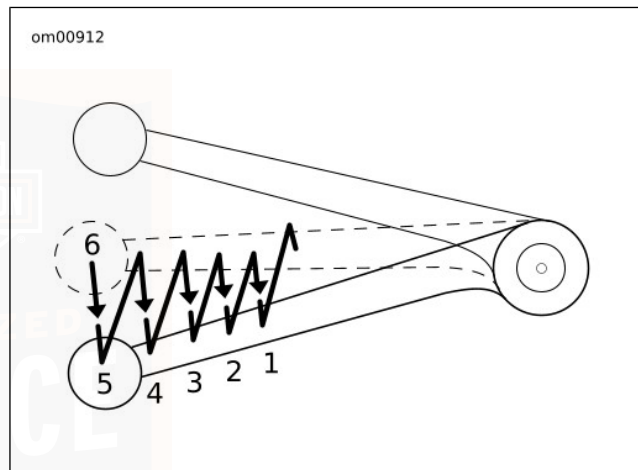

Figure 57. Shifting Sequence: Downshift

FAIRING VENT

See Figure 58 (vent shown in closed position). Vehicles are equipped with a vent in the upper dash for ventilation. The vent can be adjusted to optimize airflow to the rider and to minimize wind buffeting. Keeping the vent open will reduce turbulence.

NOTE

For best results, begin with vent open in middle position then adjust for desired airflow.

Open: Rock the lever (1) up to open the vent (2).

Close: Rock the vent lever down to close the vent.

Keep the vent free of foreign objects. Periodically clean the vent mechanism to remove dirt, bugs and leaves, and to keep all parts from sticking. Clean vent door if it becomes difficult to open or close. Refer to: AFTER RIDING > FAIRING SPLITSTREAM VENT CARE (Page 170).

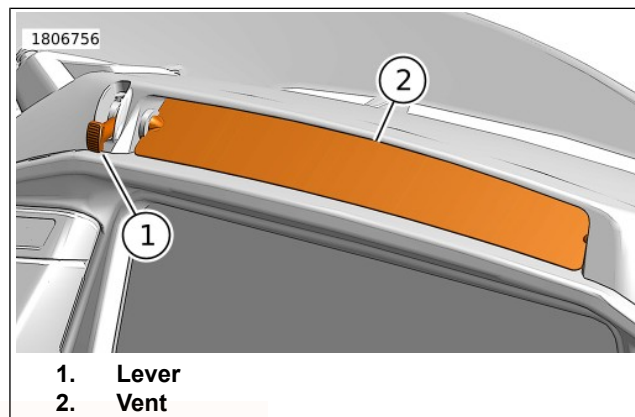

Figure 58. Fairing Splitstream Vent

ADJUSTABLE AIR DEFLECTORS

See Figure 59. Your motorcycle has adjustable air deflectors located along the left and right edge of the fairing. These deflectors can be rotated to direct airflow for rider and passenger comfort and to minimize wind buffeting.

Adjust: With the vehicle parked, grasp the outer edge of the deflector and pivot to the desired position.

NOTE

For optimum rider comfort, fine-tune air deflectors for desired amount and direction of airflow. Optimized rider comfort is dependent on rider proportions and weather conditions.

Minimizing wind buffeting is achieved when air deflectors are fully closed.

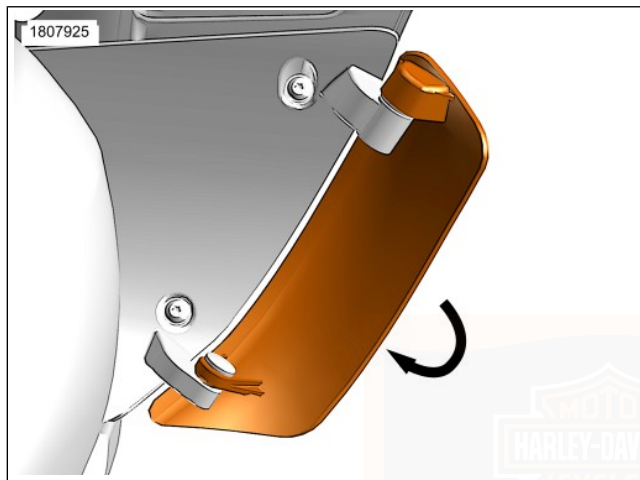

Figure 59. Air Deflector

SADDLEBAGS

⚠ WARNING

Do not exceed saddlebag weight capacity. Put equal weight in each bag. Too much weight in saddlebags can cause loss of control, which could result in death or serious injury. (00383a)

⚠ WARNING

Do not operate motorcycle without saddlebags attached because they contain side and/or rear reflectors. Motorcycle operation without reflectors can violate local regulations and lead to decreased visibility of the motorcycle to other motorists, which could result in death or serious injury. (12904a)

NOTE

Maximum saddlebag weight capacity is 20 lb (9.1 kg) in each saddlebag.

Opening

1. See Figure 60. Unlock saddlebag lock with the key.
2. Lift the saddlebag lever.
3. Lift the lid from the inner side of the saddlebag.

Closing

1. See Figure 60. Close the saddlebag lid.
2. Push the lever down to engage the latches. Check that the lid is secure.
3. Lock the saddlebag.

Remove

1. See Figure 60. Open the saddlebag.
2. See Figure 61. Turn the mounting screw levers counterclockwise to remove the mounting screws from the support bracket.
3. Lift the saddlebag from the saddlebag rail.

NOTE

- *Do not drag or scrape saddlebags on the ground. Improper care can damage the saddlebags.*
- *Saddlebags with a curved bottom will not rest upright on the ground. Set saddlebags on a level surface to prevent tipping.*

Install

1. See Figure 61. Carefully place saddlebag in position on saddlebag rail. Align the mounting grommets with the support bracket.

NOTE

The rear mounting screw lever will interfere with the saddlebag cover unless positioned with lever pointed downward.

2. Install the mounting screws through the grommet into support bracket. Turning the lever clockwise, tighten the mounting screws so the levers are pointed downward between the 3 o'clock and 9 o'clock positions as shown.
3. Check that the saddlebag is secure on the motorcycle.
4. Close and lock the saddlebag.

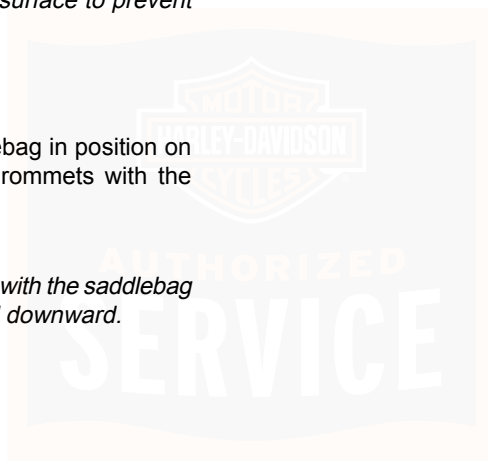

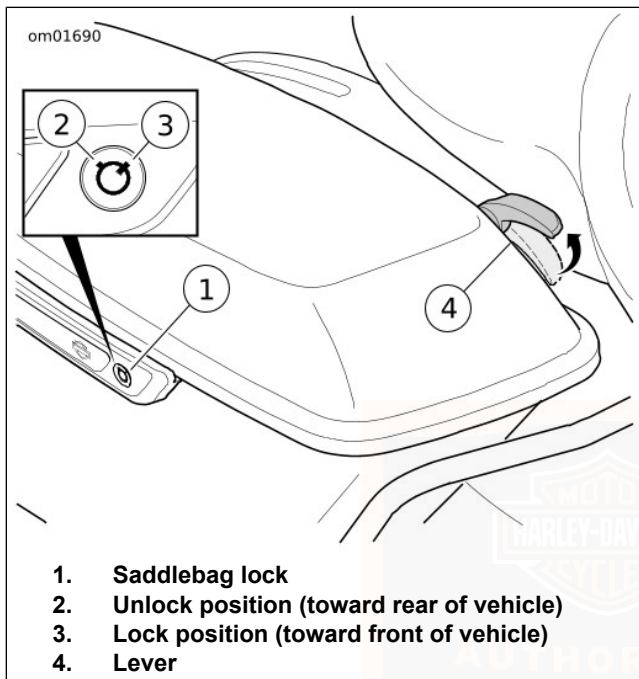

Figure 60. Saddlebag

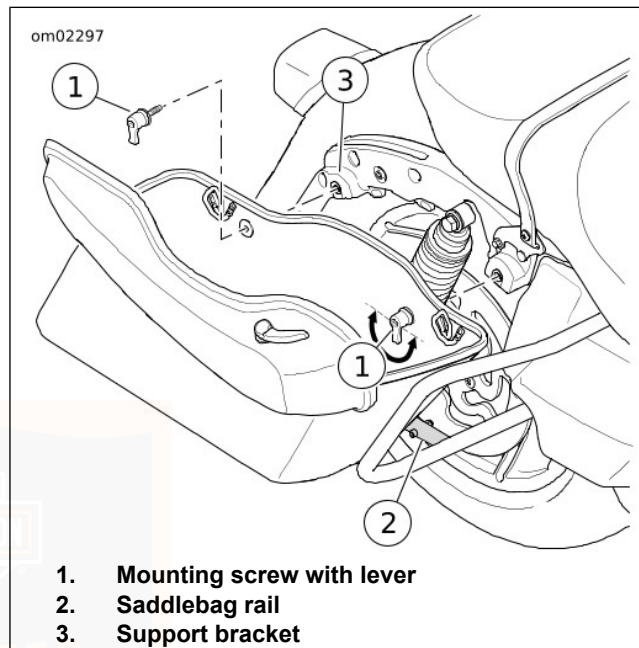

Figure 61. Saddlebag Removal/Installation

LUGGAGE

⚠ WARNING

See **ACCESSORIES AND CARGO** section within the **SAFETY FIRST** section in your owner's manual. Improper cargo loading or accessory installation can cause component failure and adversely affect stability, handling and performance, which could result in death or serious injury. (00021c)

⚠ WARNING

Do not exceed the motorcycle's **Gross Vehicle Weight Rating (GVWR)** or **Gross Axle Weight Rating (GAWR)**. Exceeding these weight ratings can lead to component failure and adversely affect stability, handling and performance, which could result in death or serious injury. (00016f)

- GVWR is the total weight of the motorcycle, accessories, rider, passenger and cargo that can be safely carried.
- GAWR is the maximum amount of weight that can be safely carried on each axle.
- See information label on frame steering head or frame downtube for GVWR and GAWR.

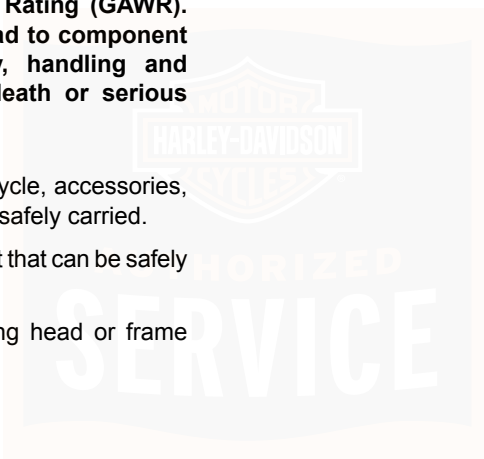

⚠ WARNING



Improper loading of cargo or installation of accessories can affect motorcycle stability and handling, which could result in death or serious injury.

- **Keep cargo weight concentrated close to the motorcycle and as low as possible to minimize the change in the motorcycle's center of gravity.**
- **Distribute weight evenly on both sides of the vehicle.**
- **Do not load bulky items too far behind the rider or add weight to the handlebars or front forks.**
- **Do not exceed maximum load capacity stated on the label for bags, luggage, and racks, if equipped. Combined load of luggage rack and Tour-Pak must not exceed load capacity on the label within the Tour-Pak.**
- **Do not exceed the maximum load capacity stated within the media compartment, when indicated and if equipped.**

- **Check that cargo is secure. The cargo cannot shift while riding. Periodically recheck load.**
- **Close and lock luggage before riding or leaving the vehicle unattended.**
- **Accessories that change the operator's riding position may increase reaction time and affect handling of the motorcycle.**
- **Items with large surface areas, such as fairings, windshields, backrests and luggage racks (if equipped) can adversely affect stability and handling.**

(14717c)

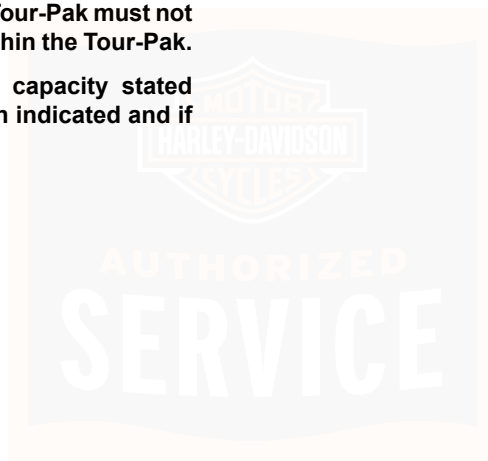

SYSTEM SETTINGS

Settings Menu

See Figure 35. To access settings menu select settings (1) from main menu.

Some of the settings may be disabled or not displayed, depending on the model and region. For a list of all the categories that can be configured, see Table 29.

Configure the system settings before riding the motorcycle, with the motorcycle stationary and set to accessory mode. Adjust the options to match your personal riding style, and to make best use of any features or devices that you may be using. If there are problems with any features in the radio, first check the relevant settings.

If audio accessories have been added to the motorcycle, see the instruction sheets for proper configuration and operation of those accessories.

Settings topics include Bluetooth, Sound, Display, System, Ride mode, Tuner and Wi-Fi

Device Manager

Within the Device Manager menu you will be able to turn Bluetooth ON or OFF. With Bluetooth ON you will be able to pair your phone, pair a rider and/or passenger headset. If

multiple phones are paired you will be able to change which one to connect to. By selecting an already connected device you can disconnect the device or change its settings: for example on a connected phone you can choose to turn ON or OFF Calls or Media. On a connected headset you can choose to turn ON or OFF Calls, Media or Prompts. You can also switch the headset between Rider or Passenger role.

Pairing Device

1. Activate Bluetooth on your device.
2. See Figure 35. **Select:** Settings menu (1).
3. **Select:** Device Manager.
4. **Select:** Add new device.
 - a. **Phone: Select:** Add New Phone.
 - b. **Headset: Select:** Add New Headset.
5. Follow on screen prompts to complete pairing.

Wi-Fi

Within the WiFi menu you will be able to turn WiFi ON or OFF. With WiFi ON you will be able to connect to an available WiFi network or WiFi Hotspot.

NOTE

Wi-Fi connection only compatible using a secure 5GHz Wi-Fi band network. If not Secure and 5GHz the Wi-Fi network will not be visible as an available network.

Table 35. Wi-Fi Status Icons





ICON	Status
	Normal: Low signal strength shown
	Error: High shown

Table 35. Wi-Fi Status Icons

ICON	Status
	No signal
	Cloud connection fault

1. See Figure 35. **Select:** settings menu (1).
2. Under Settings, select Wi-Fi.
3. Connect and disconnect from available networks.
4. Select options by using the LHCM or touchscreen.

Sound

1. See Figure 35. **Select:** Settings menu (1).
2. Under Settings, select sound.

3. Categories include audio routing, application volume, auto volume control, equalizer, fader, speaker setup and VOX Sensitivity.
4. Adjust available settings as desired by using LHCM or touchscreen.

Audio Routing

For each selection, select item for audio to be heard through. Highlight selection Music/Media or Prompts. Select Speakers or Headset.

Application Volume

Volume through speakers, rider headset and passenger headset can be adjusted individually through the IFCU. Rider headset and passenger headset can have speaker volume levels adjusted for media, prompts and phone.

Speaker levels are only adjustable for media and prompts.

Auto Volume Control

The automatic volume control setting adjusts the overall volume according to vehicle speed. This function allows the volume to be set to a comfortable level while the motorcycle is stopped or traveling slowly. The volume automatically

increases to compensate for engine, wind, and other ambient noise factors as vehicle speed increases.

Equalizer

The equalizer allows the rider to adjust the sound of the audio to their liking. There are standard equalizer settings that can be used or custom may be selected to allow user to adjust individual frequency bands.

Fader

The fader is used to adjust the sound front or back to the riders liking.

Speaker Setup

Used to setup audio system when adding or changing speakers.

- Device Status- Allows user to see software version on amplifier.
- Speaker status- Allows user to test function of speakers.
- Speaker Config- Allows user to configure newly installed speakers.

VOX Sensitivity

When voice input is picked up by the rider or passenger microphone, the intercom is automatically activated. This process is known as "breaking VOX".

The rider or passenger can initiate intercom communication. When the intercom is active, tuner and media volume are automatically reduced so the intercom can be heard through the headsets.

For privacy, the intercom is only heard through the rider and passenger headsets. It is not heard through the speakers.

Microphone sensitivity and headset volume can be adjusted. The microphone sensitivity (VOX) applies to both rider and passenger microphones. The rider and passenger headset volumes are adjusted independently.

NOTE

Some local governments prohibit or restrict the use of headset (helmet-mounted) speakers. Check with local authorities and obey all applicable laws and regulations.

Display

The appearance and settings of the IFCU display can be adjusted through the Display menu.

1. See Figure 35. **Select:** Settings menu (1).

2. **Select:** Display.
3. Select from the following options.

Layout Set desired IFCU display layout. Select from Cruise, sport and tour.

Auto Day/Night Mode enable or disable Auto day/night mode. When enabled the display will automatically regulate the brightness setting.

Brightness Adjust IFCU display brightness when auto day/night mode is not enabled.

High Contrast Enable or disable high contrast mode. See Figure 42.

Color Choose primary background color of the IFCU display.

System

The appearance and settings of the IFCU display can be adjusted through the Display menu.

1. See Figure 35. **Select:** Settings menu (1).
2. **Select:** System.
3. Select from the following options.

Date & Time

Setting date, time & time zone can be done by choosing automatic or manual.

Automatic requires a connection to the GPS signal. Manual requires user to input data.

Date & time formats can be chosen on screen to suit the user.

Language

This is where the preferred language the system uses is chosen.

Units

Choose desired units of measure to be displayed for distance, temperature and pressure.

Bike Function Setup

Fog lights can be turned on and off.

NOTE

After selecting fan control status turn bike OFF for 1 minute then turn ON to finish setup.

Fan control can be set to Off, Auto or On.

Audio power can be shut off and on.

Hand grips power can be shut off and on.

Locks can be locked and unlocked.

Software Update

For information on software update, see INFOTAINMENT CONTROL UNIT (IFCU) OPERATION > SOFTWARE UPDATES (Page 156).

Ride Mode

1. See Figure 35. **Select:** settings menu (1).
2. **Select:** Ride Mode.
3. Select from the following options.

Enable and Disable Available Ride Modes.

Figure 62 The list of ride modes selectable through the mode switch can be customized. To enable or disable a ride mode use the check box (1) next to each ride mode in the ride mode menu.

NOTE

Road ride mode can not be disabled.

Setting Custom Ride Mode A and B

Custom ride modes must be set up before they can be used. To set up a custom ride mode navigate to Ride Modes menu. Select customize menu (2) next to custom ride mode to be set up. Settings from an existing ride mode can be copied and used as a starting point when setting up a custom ride mode. Refer to Table 36 for available selections.



Figure 62. Ride Modes Settings

Table 36. Custom Ride Mode Settings

Selection	Result
Engine Map	Sets overall power delivery characteristics in the custom ride mode. Selection will copy engine map characteristics from one of the pre set ride modes.
Engine Braking	Adjusts how much engine braking will be enabled in the custom ride mode.
Throttle Response	Adjusts the intensity of throttle response felt by the rider in the custom ride mode.
Traction Control	The traction control level adjusts how much rear wheel slip the system will allow. Selection will copy traction control characteristics from one of the pre set ride modes.
Anti-Lock Braking	Adjusts how much ABS intervention and drag-torque slip control intervention is present within the custom ride mode. Selection will copy ABS characteristics from one of the pre set ride modes.

Table 37. Traction Control Settings

TCS Sub-mode	Intervention	Slip Possible	Available for Selection in Customization
Rain	Max	Min	Yes
Road	Mild	Mild	Yes
Sport, Track	Min	Max	Yes
Track+	Min -Track tuned	Max -Track tuned	Yes
TCS Disabled	None - Disabled	Unlimited	No -but TCS can be disabled in any ride mode using the TC button (push and hold from a stop). TCS remains off when changing ride modes except if rain mode is selected; TCS will be automatically re-enabled.

Table 38. ABS Settings

ABS Sub-Mode Setting	Braking Intervention Level	Wheel Slip Possible During Braking	Drag Torque Slip Possible	Front-to-Rear Linked Braking	Rear-to-Front Linked Braking	Available for Selection in Customization
Rain	Max	Low	Low	Enabled	Enabled	Yes
Road, Sport	Mild	Medium	Medium	Enabled	Enabled	Yes
Track	Min	High	High	Enabled	Disabled	Yes
Track+	Min - Track tuned	Very high - Track tuned	High - Track tuned	Disabled	Disabled	No

Tuner

NOTE

Some selections not available in all regions.

1. See Figure 35. **Select:** Settings menu (1).
2. **Select:** Tuner.
3. Select from the following options. WB, RDS, AF, TA, REG and DAB-FM.
4. **Select:** Category. Enable or disable categories of radio stations.

Phone

1. See Figure 35. **Select:** Settings menu (1).
2. **Select:** Phone.
3. Select from the following options.

Select: Reply Messages to choose a preprogrammed reply message, or to create a custom reply.

Select: Contacts Display Order to select if contacts will be displayed with first or last name first.

AUDIO

Selecting Media Source

Select the media source icon (8) IFCU on the screen. Refer to: OPERATION > INFOTAINMENT CONTROL UNIT (IFCU) (Page 98).

Navigate to the desired media by using the navigate buttons on the LHCM direction pad. Refer to: OPERATION > LEFT HAND CONTROL SWITCHES (Page 88).

See Figure 63. Select the desired media source by pressing OK/enter (5) button on LHCM or pressing icon on the screen.

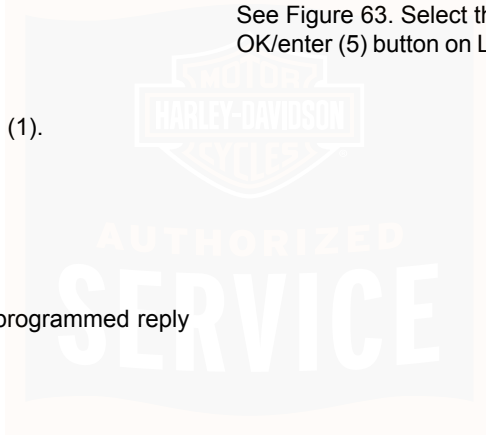

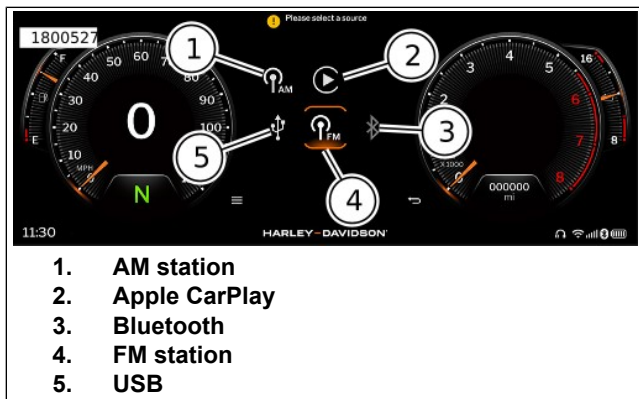

Figure 63. Selecting Source

Tune/Seek

Once the desired band is selected (AM, FM), tune or seek stations by using the arrows on the touch screen or Previous (12) or Next (7) buttons on the RHCM. Refer to: OPERATION > RIGHT HAND CONTROL SWITCHES (Page 93).

See Figure 65. A list of available stations can be viewed by selecting the stations list icon (1).

Short press: Advances to the next frequency increment.

Long press: Accelerates through the frequencies until the switch is released.

When tuning or seeking, tuner continues to wrap around at the beginning or end of frequency range.

Press back button on LHCM to return to previous screen.

Finding a Media File

See Figure 64. The browse feature can be used to find different types of media files on USB-connected media devices. File browsing features are not available for Bluetooth streaming media devices.

Categories to browse include artist, album, songs, play list and audio books. Selecting a category will show a list of items, sorted by the category selected.

Scroll through list to find desired item. Select item to be played.



Figure 64. Browse Categories

Favorites

There are 4 types of Favorites menus: Tuner/ Media/ Contact/ Global. Contact Favorites must be selected from the Phone Contact list. Global favorites must be selected from one of the other three Favorites lists.

Setting a Favorite for Tuner or Media

If selecting a file from a removable media device, the radio will do nothing unless the media device is connected.

NOTE

Bluetooth-connected device cannot be saved as favorites.

1. Tune to a radio station or file from USB-connected device.
2. See Figure 65. Press favorites (2) on screen or Navigate down button on LHCM.
3. Press and hold one of the favorite (+) preset buttons from the list or press OK/enter button on LHCM.

NOTE

An existing Favorite can be replaced or deleted with a long press on the selected favorite.

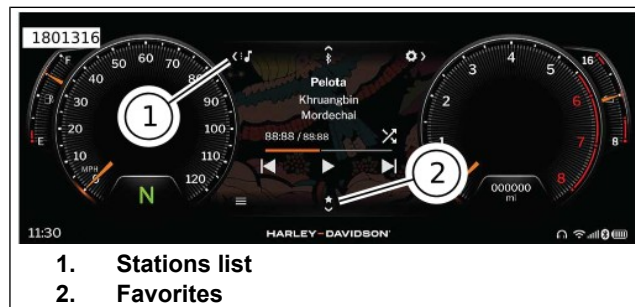

Figure 65. Stations List and Favorites

Voice Recognition

Seeking a Station:

1. **Select:** Voice recognition switch.
2. **Speak:** "Seek Up" or "Seek Down" into microphone.

Tuning a Station

1. **Select:** Voice recognition switch.
2. **Speak:** "Tune to" along with the frequency into microphone (such as "Tune to ninety-seven point one"). The radio automatically tunes to appropriate band (such as AM or FM) according to frequency selected.

Selecting a Band

1. **Select:** Voice recognition switch.
2. Speak the band into microphone "AM" or "FM". Media such as Bluetooth Paired device or USB is also available if connected.

NAVIGATION

Navigation (If Equipped)

NOTE

Navigation function not equipped in all markets. If navigation icon is not enabled a prompt to enable subscription based navigation will be shown when selecting navigation.

The navigation function is intended to assist you when traveling. In some circumstances, information provided by the navigation function may be incomplete, incorrect or outdated. Road conditions, traffic laws and restrictions (such as no left turns, street closures, one way streets, road construction detours, and so on) can frequently change. Before following any instruction, check that the instruction can be done safely and legally. Program and review navigation routes with the vehicle stopped. If necessary, safely park the vehicle if there

is difficulty following the route guidance or to program a new route.

NOTE

- *Some advanced features require a Wi-Fi connection to function. For best maps and navigation experience pair a Wi-Fi hotspot from your mobile device.*
- *Navigation not available in all markets.*

Setting Route

NOTE

When parked keyboard will appear. When moving, non accessible functions will be grayed out. When moving, voice commands or a list of Point Of Interest (POI) must be used to find a destination in system. Search results will appear on screen. Select destination to start route.

Setting route through IFCU

1. Select navigation on home screen. Refer to: OPERATION > INFOTAINMENT CONTROL UNIT (IFCU) (Page 98).
2. See Figure 67. Select search (3) icon.
3. See Figure 66. Use the text box (1), search (2), or POI suggestions (3) to choose a destination.

4. See Figure 32. Press OK/enter (8).

See Figure 67. To access the menu selections on the IFCU select the menu icon (4) on the screen.

NOTE

The time, date and time zone must all be set correctly for enhanced functions to work.

Enhanced Wi-Fi Functions Using Wi-Fi Pair mobile device to infotainment. The navigation function offers additional features when connected to a Wi-Fi hotspot, (live traffic, weather).... See settings for pairing

Voice recognition

Some navigation functions can be controlled using the voice recognition feature. With a headset connected, press the voice recognition switch. Speak the desired command into the headset microphone.

See Voice recognition in OPERATION > INFOTAINMENT CONTROL UNIT (IFCU) (Page 98) for more information.

Navigation Displays

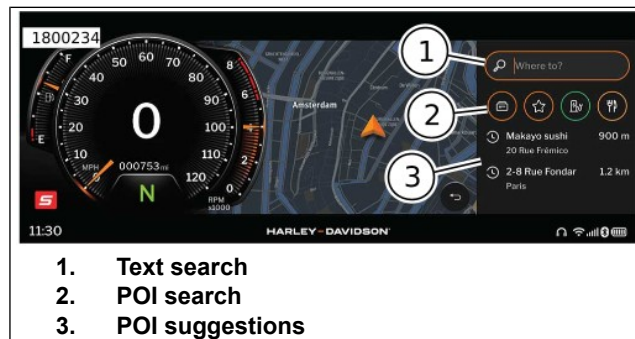

Figure 66. Destination Options



Figure 67. Navigation Selections



Figure 68. Routes Options

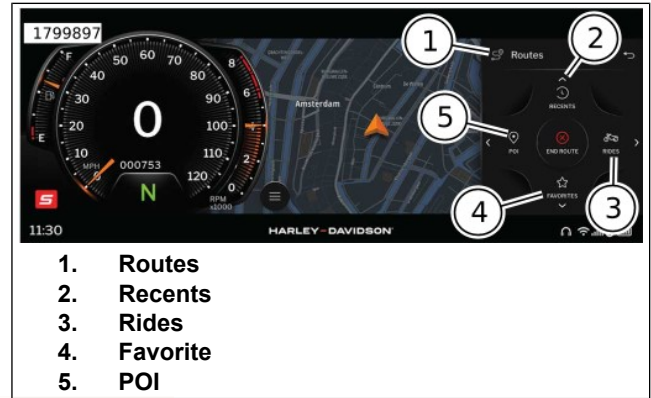

Figure 69. Routes

Active navigation showing turn by turn instruction



Figure 70. Navigational Instruction

PHONE

1. See Figure 35. **Navigate:** Home > Phone (3).
 - a. If no phone is paired, you will be prompted to Add Phone.
2. Select one of the phone features. See Figure 72.

Connecting a phone to the USB port allows the phone to charge and may provide additional media features. However, a USB connection alone will not operate the phone features.

NOTE

Using the factory phone USB cable ensures proper performance for data exchange.

NOTE

- A phone must first be paired before call or text notifications can be viewed through the IFCU.
- A headset with microphone is required to make and receive calls via Bluetooth.



Figure 71. Add Phone

Making a Call

1. See Figure 35. Select the phone (3).
2. See Figure 72. Select contacts (1) or call history (2) to find contact number.
3. Select contact to call.
4. Press OK/enter on LHCM to call.
5. See Figure 73. To place caller on hold, select hold (4) and press OK/enter. Press OK/enter again to remove from hold.
6. To end call, select end call (3) press OK/enter.

Voice recognition can be used to place a call through the IFCU.

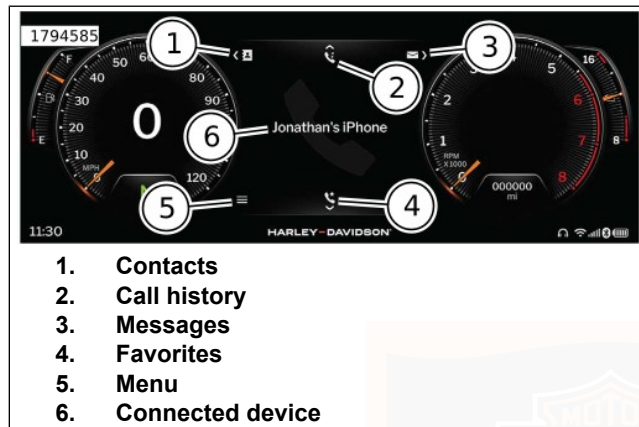

Figure 72. Phone Selections

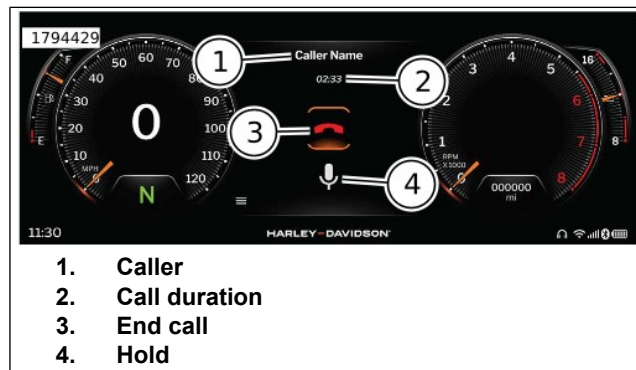

Figure 73. In Call Functions

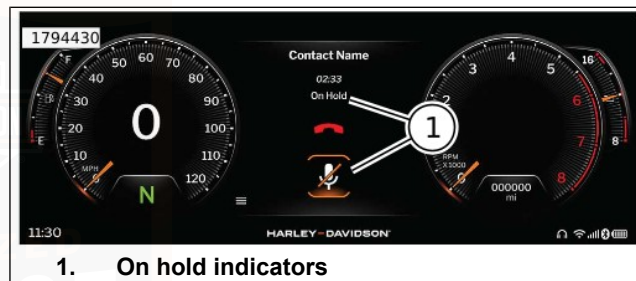

Figure 74. Call On Hold

Receiving a Call

See Figure 75. When receiving a call a notification will be displayed on the IFCU.

Use the LHCM to answer (3), ignore (4), or send a text reply (2).

See Figure 73. To end the call select end call (3).



Figure 75. Incoming Call

Messages

See Figure 76. Messages will be displayed on IFCU and can be selected using LHCM.

See Figure 72. To access messages select Message Icon(3).

154 Infotainment Control Unit (IFCU) Operation

Message text will be converted from text to speech while in motion. The option to reply with a call or create a text with voice recognition will be available. Message text will appear as text when not in motion with an option to play as text to speech.



Figure 76. Messages

Projection Mode

During projection mode, the Apple CarPlay image is displayed. Also, the tuner or media selections are paused, active route is cancelled and projection mode assumes priority. Upon exiting projection mode all items return to normal radio functions.

CarPlay is compatible with iPhone 5 and later models.

NOTE

Apple CarPlay does not require an app download. When connected, not all iPhone apps will be displayed on the screen, only Apple approved apps.

CarPlay will not activate without the use of a headset and microphone.

Apple CarPlay is available wirelessly. Phone will need to be Bluetooth paired and connected. USB connection can also be used.

1. Switch power to Accessory or Ignition mode. Refer to: OPERATION > KEYLESS IGNITION (Page 69).
2. See Figure 77. To enable projection mode select Apple CarPlay from the home menu.

See Figure 78. To exit Apple CarPlay select close application (1) or H-D logo (2).



Figure 77. Apple CarPlay Available



Figure 78. Apple CarPlay Exit

BIKE FUNCTIONS

Bike Functions

To access the bike functions menu on the IFCU, long press the Main menu/Bike function button. Refer to: OPERATION > LEFT HAND CONTROL SWITCHES (Page 88).

Bike functions include (if equipped) foglight off/on, fan control off/auto/on, handgrips off/low/med/high, audio off/on

To change function state, move up or down to desired function, move left or right to desired state and press enter.

See Figure 79. Select the return icon to exit bike functions.



Figure 79. Return Icon

SOFTWARE UPDATES

Harley-Davidson periodically provides software updates for the infotainment system on www.harley-davidson.com.

NOTE

- *Downloading software updates requires a computer platform loaded with the Windows operating system. **Do not** use Apple products for downloading updates.*
- *Password encrypted drives are not compatible. Make sure that there are no other files on the USB drive.*

- *Do not interrupt the installation process. Leave vehicle in accessory mode and keep the USB drive installed until the installation process is complete.*

1. Verify vehicle is powered ON in accessory mode. See OPERATION > KEYLESS IGNITION (Page 69).
2. Check software version.
 - a. See Figure 80. Using left hand control or touch screen, navigate to **Settings>System>System Info>Product Information**. This menu will show the current software version on the IFCU. See OPERATION > INFOTAINMENT CONTROL UNIT (IFCU) (Page 98).
 - b. Check for latest software version. See www.h-d.com/infotainment-support.
3. Update software. See www.h-d.com/infotainment-support.
 - a. Download the latest software version to USB-C device.
 - b. Unzip the downloaded file to extract the file. The new file must be at the root directory of your USB-C for it to be detected by the IFCU. Only the latest file should be present at the root directory level.

- c. Connect USB-C to motorcycle. See OPERATION > MEDIA COMPARTMENT (Page 116).

NOTE

Update will automatically begin once update file is recognized by the IFCU.

- d. Verify correct update is available.

- e. Load update.
- f. Allow update to complete.
- g. Remove USB-C.

4. Return to software information to verify correct version has been loaded.



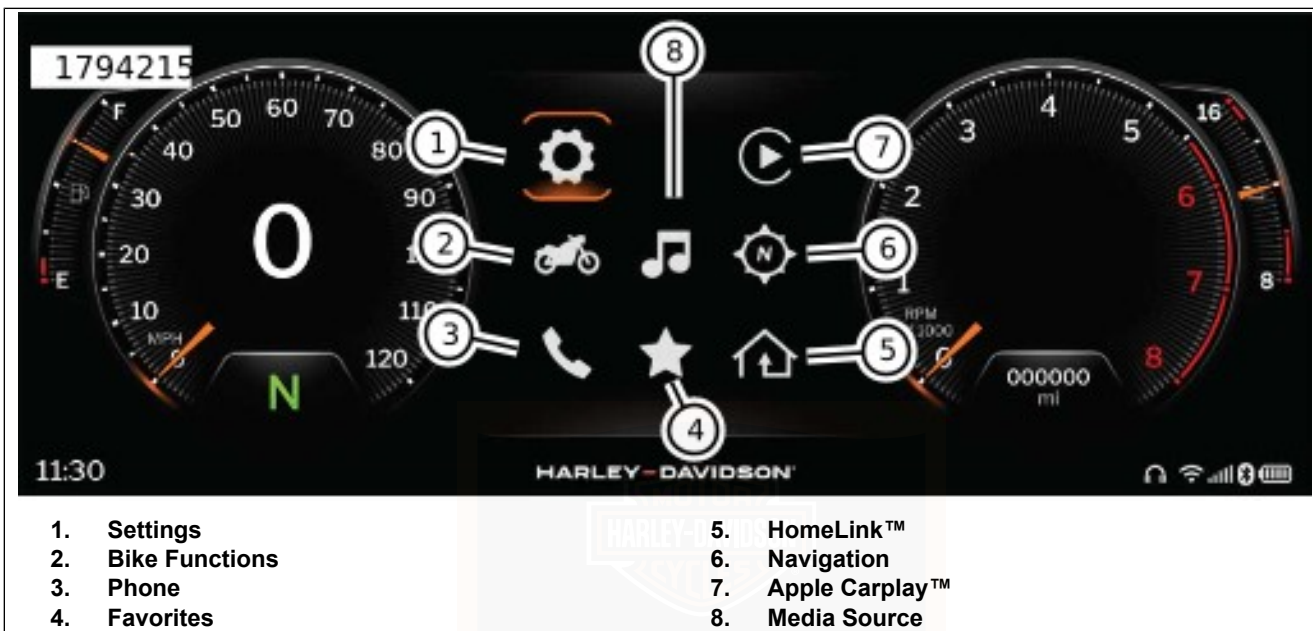

Figure 80. IFCU Menu Selections

HELP

For additional instruction and information for set up or operation of the IFCU system, see online resources at Refer to: <https://service-qc.harley-davidson.com/qr?sid=IFCU> or scan QR code. See Figure 81.



Figure 81. QR Code

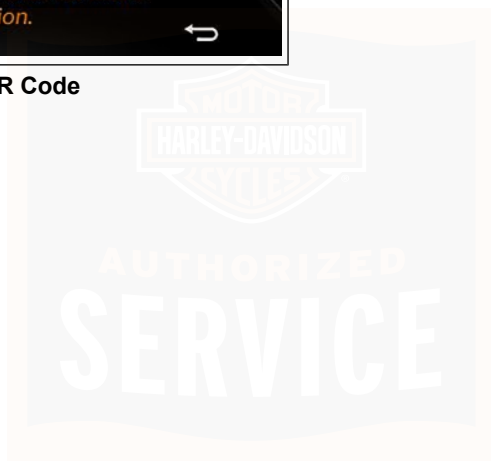

NOTES



GENUINE MOTOR PARTS AND ACCESSORIES

Stop at your Harley-Davidson dealer to pick up a copy of the Genuine Motor Parts and Accessories catalog or go to www.harley-davidson.com to view thousands of Genuine Motor Accessories that are available for Harley-Davidson motorcycles.

The website includes the following tools and resources for accessorizing and personalizing your motorcycle.

Online Catalog

The full Genuine Motor Parts and Accessories catalog is available online in Portable Document Format (PDF) format. The catalog includes hundreds of pages of Harley-Davidson accessories and maintenance products.

Shop for Your Bike

Browse through categories of accessories and options available specifically for your motorcycle. View product descriptions, pricing, fitment and online instruction sheets for many of the available products.

CLEANING AND GENERAL CARE

- Harley-Davidson cleaning products are tested extensively for use on motorcycle surfaces. These products are formulated to be compatible with one another. See a Harley-Davidson dealer to purchase recommended cleaning products. Refer to Table 39 and Table 40.
- Care, cleaning and protection of the vehicle surfaces is the responsibility of the owner.
- Clean and protect the cosmetic surfaces on your motorcycle as often as possible to inhibit rust and corrosion.
- Some painted finishes and other surfaces may be scratched if gravel, dirt or grime are rubbed across the surface during washing. Use clean towels and avoid rubbing sediment across gloss finishes.
- Do not use paper towels, cloth diapers or other materials with nylon fibers which can cause fine scratches to surfaces.
- For repair of scratched surfaces, see a Harley-Davidson dealer.

▲ WARNING

Observe warnings on labels of cleaning compounds. Failure to follow warnings could result in death or serious injury. (00076a)

▲ WARNING

Do not wash brake discs with cleaners containing chlorine or silicone. Cleaners containing chlorine and silicone can impair brake function, which could result in death or serious injury. (00077a)

NOTICE

Do not use a pressure washer to clean motorcycle. Using a pressure washer can result in equipment damage. (00489c)

NOTICE

Use of abrasive products or powered buffing equipment will cause permanent cosmetic damage to body panels. Use only recommended products and techniques outlined in this manual to avoid damaging body panels. (00245b)

Cleaning Wheels and Tires

NOTE

Corrosion to wheels is not considered to be a defect in materials or workmanship.

- Wheels can corrode or be cosmetically damaged if they are not properly cleaned, polished and preserved.
- Harley-Davidson recommends that wheels be cared for weekly.
- Keep wheels clean from harsh chemicals, acid-based wheel cleaners, salt, and accumulated brake dust.
- After washing wheels with WHEEL & TIRE CLEANER, use the polish and sealing products according to the type of wheels on your motorcycle. Refer to Table 41.

RECOMMENDED CLEANING PRODUCTS

The following products are recommended for Harley-Davidson motorcycles, parts and accessories. Your motorcycle may not have all the components shown in the tables.

Table 39. Recommended Cleaning and Care Products

PRODUCT PART NO.	PURPOSE	FRAME	BODY PANELS	WHEELS	DENIM FINISH	OTHER
BARE METAL POLISH 93600028 (U.S.) 93600083 (Non-U.S.)	Polishes non-clear coated polished aluminum or polished stainless steel surfaces. ⁽¹⁾	As applicable				
BLACK LEATHER REJUVENATOR 93600033 (U.S.) 93600081 (Non-U.S.)	Rejuvenates black leather products so they look brand new.	No	No	No	No	Black leather goods
BUG REMOVER 93600122 (U.S.) 93600140 (Non-U.S.)	Removes bugs from metal, plastic or painted surfaces.	Yes	Yes	Yes	Yes	
CHROME CLEAN & SHINE 93600031 (U.S.) 93600082 (Non-U.S.)	Shines chrome-plated surfaces and cleans brushed aluminum or stainless steel surfaces.	As applicable				
DENIM PAINT CLEANER 93600124 (U.S.) 93600127 (Non-U.S.)	Waterless quick cleaner and detailer.	Yes	Yes	Yes	Yes	
ENGINE BRIGHTENER 93600002 (U.S.) 93600068 (Non-U.S.)	Rejuvenates wrinkle black engine finish.	No	No	No	No	Wrinkle black engines
EVERYDAY DETAILER 93600157 (U.S.) 93600158 (Non-U.S.)	Cleans, shines, brightens and protects in a short amount of time.	Yes	Yes	Yes	No	

Table 39. Recommended Cleaning and Care Products

PRODUCT PART NO.	PURPOSE	FRAME	BODY PANELS	WHEELS	DENIM FINISH	OTHER
GRAPHENE SPRAY COATING 93600166 (U.S.) 93600169 (Non-U.S.)	Provides a protective barrier for glossy paint surfaces and chrome. Repels water and dust.	Yes	Yes	As applicable	No	
GLOSS DETAILER 93600123 (U.S.) 93600125 (Non-U.S.)	Produces high gloss with UV protection. Allows chrome to breathe, unlike wax. Good for windshields.	Yes	Yes	Yes	No	
HARLEY TRAVEL CARE KIT 93600149 (U.S. only)	Travel size cleaning and care products. (Not for use on denim finishes.)	Yes	Yes	Yes	No	
LEATHER PROTECTANT 93600034 (U.S.) 93600080 (Non-U.S.)	Weatherproofs and preserves leather products.	No	No	No	No	Leather goods
QUICK WASH 93600162 (U.S.) 93600171 (Non-U.S.)	A quick wash for a lightly soiled motorcycle. Cleans all surfaces, sheeting action prevents spots.	Yes	Yes	Yes	Yes	
SCRATCH & SWIRL REPAIR 93600155 (U.S.) 93600156 (Non-U.S.)	Removes fine scratches and swirls.	Yes	Yes	No	No	
SEAT, SADDLEBAG & TRIM CLEANER 93600167 (U.S.) 93600170 (Non-U.S.)	Cleans and conditions vinyl, leather and plastic. Use on seats, saddlebags, inner fairings and any other trim.	No	No	No	No	Seats, saddlebags and trim

Table 39. Recommended Cleaning and Care Products

PRODUCT PART NO.	PURPOSE	FRAME	BODY PANELS	WHEELS	DENIM FINISH	OTHER
SPRAY CLEANER & POLISH 93600029 (U.S.) 93600084 (Non-U.S.)	Aerosol quick cleaner and detailer. Reduces static attraction to dust. Works great for removing bugs. ⁽¹⁾	Yes	Yes	Yes	No	
SUNWASH BIKE SOAP 93600129 (U.S.) 93600141 (Non-U.S.)	Thorough washing of all surfaces with a wash mitt. Reduces hard water spots when washing a motorcycle in the sun.	Yes	Yes	Yes	Yes	
WHEEL & TIRE CLEANER 93600121 (U.S.) 93600126 (Non-U.S.)	Removes brake dust and road grime from wheels, tires and whitewalls. Do not use on frames or anodized parts.	No	No	Yes	No	Black-coated exhaust pipes and mufflers

(1) DO NOT use BARE METAL POLISH or SPRAY CLEANER & POLISH on coated aluminum wheels, protective coating will be removed.

Table 40. Recommended Surface Care Products

PRODUCT PART NO.	PURPOSE
BUG EATER SPONGE 93600110	When paired with water and BUG REMOVER, the BUG EATER SPONGE breaks down and dissolves baked on bugs and road grime.
CLEANING BRUSH KIT 94844-10	Brush kit for detailing your motorcycle.
DETAILING SWABS 93600107	Large cotton swabs for cleaning crevices and detailed surfaces.

Table 40. Recommended Surface Care Products

PRODUCT PART NO.	PURPOSE
BIKE WASH BUCKET 93600133	Wash bucket. Includes GRIT GUARD insert.
HOG BLASTER MOTORCYCLE DRYER 94651-09A	Blows a stream of warm dry filtered air. Reduces streaks and water spots.
MICROFIBER APPLICATORS (4 pack) 93600168	Use to apply most wax, coating, sealant, and dressing products.
MICROFIBER DETAILING CLOTH 94663-02	Highly absorbent detailing cloth for polishing and sealing. Contains no nylon fibers.
MICROFIBER DETAILING CLOTHS (3 pack) 93600136	Highly absorbent detailing cloths for polishing and sealing.
MICROFIBER SOFT DRYING TOWEL 93600132	Washable and reusable. Provides a lint- and streak-free drying action for a professional results.
MICROFIBER WASH MITT 93600130	Premium quality microfiber washing mitten. Use with either hand.
WHEEL & SPOKE BRUSH 43078-99	Cone-shaped scrub brush for wheels.

WASHING THE MOTORCYCLE

Use only recommended cleaning and care products. Refer to Table 39 and Table 40.

NOTE

During rinsing and washing, avoid direct spray on electrical components, air filter element and any luggage or saddlebag

sealing areas (if equipped). Avoid spraying water under leather saddlebag covers (if equipped).

Preparation

1. Allow motorcycle to cool before rinsing or washing. Spraying water on hot surfaces can leave water spots and mineral deposits.

2. Rinse the motorcycle from the bottom up.
3. To loosen dried bugs or hardened dirt, allow surfaces to soak under a damp towel.

Cleaning Wheels and Tires

1. Rinse wheel and tire surfaces. Avoid splashing brake dust on chrome or painted parts.
2. Apply WHEEL & TIRE CLEANER. Allow cleaner to set for one minute.
3. Clean the wheel with a BUG EATER SPONGE or WHEEL & SPOKE BRUSH. Thoroughly scrub all brake dust and other sediments off the wheel. Accumulated brake dust can trap moisture and dirt, which leads to wheel corrosion.
4. Rinse well.

Washing the Motorcycle

NOTE

See the appropriate instructions in this section for cleaning leather, denim (flat) finishes, windshields or other special surfaces.

1. If necessary, use BUG REMOVER to remove bug splatters.
 - a. Rinse the affected surfaces during preparation.

- b. Spray the area with BUG REMOVER.
- c. Wait one minute while the BUG REMOVER penetrates the bug splatters.
- d. Use the BUG EATER SPONGE while washing to easily remove bugs.

2. Prepare the wash.
 - a. Fill a HARLEY WASH BUCKET with clean water.
 - b. Add SUNWASH BIKE SOAP, following the directions on the package.
 - c. Soak the WASH MITT and/or a BUG EATER SPONGE in the SUNWASH solution.
3. Wash all surfaces starting at the top working down toward the ground.
4. Rinse the motorcycle twice in both directions:
 - a. Rinse from the bottom up.
 - b. Rinse from the top down.

Drying the Motorcycle

1. Dry the surfaces from the top down using a SYNTHETIC DRYING CHAMOIS or a HOG BLASTER MOTORCYCLE DRYER. Avoid using any type of forced air on speakers or other sensitive components.

2. Dampen chamois in clean water and wring out the excess. The chamois is more absorbent when wet.
3. Wipe across the vehicle surface.
4. Repeat as necessary until surface is dry.

Polishing and Sealing

NOTE

If motorcycle has denim finish, skip the Polishing and Sealing procedure.

1. Apply GLAZE POLY SEALANT with a DISPOSABLE DETAILING SOFT CLOTH or MICROFIBER DETAILING CLOTH, following the instructions on the package.
2. Buff with a DISPOSABLE DETAILING SOFT CLOTH.
3. Polish and seal the wheels to prevent corrosion.

WINDSHIELD CARE

NOTICE

Polycarbonate windshields/wind deflectors require proper attention and care to maintain. Failure to maintain polycarbonate properly can result in damage to the windshield/wind deflector. (00483e)

NOTICE

Use only Harley-Davidson recommended products on Harley-Davidson windshields. Do not use harsh chemicals or rain sheeting products, which can cause windshield surface damage, such as dulling or hazing. (00231c)

- Powdered, abrasive or alkaline cleanser can damage windscreen/windshields. Ammonia-based window cleaners cause permanent yellow effects to windshields.
- Do not use gas station windshield cleaner as finish can be damaged.
- Do not use a brush or squeegee as finish can be damaged.
- Do not clean in hot sun or high temperature.

Windshields require special care. However, windshields can be washed with WINDSHIELD CLEANER - INDIVIDUAL WIPES, SUNWASH BIKE SOAP or QUICK WASH when washing the entire motorcycle. Refer to Table 39.

NOTE

- Use BUG REMOVER to soft bug splatters. Wipe clean with a BUG EATER SPONGE.
- Covering windshields with a clean, wet cloth for approximately 15-20 minutes before washing makes dried bug removal easier.

1. Use WINDSHIELD CLEANER to detail windshields.
2. Wipe dry with a clean MICROFIBER DETAILING CLOTH.

NOTE

To minimize swirl marks, clean windshield when the motorcycle is cool and parked in the shade. Faint swirl marks are normal. Swirl marks are more visible on tinted windshields.

LEATHER AND VINYL CARE

NOTICE

Do not use bleach or detergents containing bleach on saddlebags, seats, tank panels or painted surfaces. Doing so can result in equipment damage. (00229a)

Do not use ordinary soap to clean leather or fur. It could dry or remove the oils from the leather.

Leather, vinyl and other synthetic surfaces must be periodically cleaned and treated to maintain its appearance and extend its life. Clean and treat these surfaces once a season or more frequently under adverse conditions.

These surfaces are not designed for long-term exposure to inclement weather. Protect these surfaces with a Harley-Davidson Seat Rain Cover or Motorcycle Storage Cover (sold separately).

1. Vacuum or blow dust off surface.

2. Thoroughly clean surfaces with SEAT, SADDLEBAG & TRIM CLEANER, following directions on the bottle.
3. Allow the material to dry naturally and completely at room temperature before applying other products to the material. Do not use artificial means to dry the material quickly.
4. For leather only, rejuvenate faded black surfaces with BLACK LEATHER REJUVENATOR, and apply LEATHER PROTECTANT to weatherproof and preserve the leather.

NOTE

Many Harley-Davidson accessories and seats are made of either treated or untreated leather or have leather inserts. Natural materials age differently and require different care than man-made materials. Seat covers and panels made of leather gain "character", such as wrinkles, with age. Leather is porous and organic. Each leather product settles into its own distinct form with use. Your leather product matures into its own custom shape and style from the sun, rain and time. This maturing is natural and enhances the custom quality of your Harley-Davidson motorcycle.

AUDIO SYSTEM CARE

Use only Harley-Davidson recommended products and methods to keep the radio, speakers and other audio system components clean and in good condition. Do not use any abrasives, polishes or rubbing compounds to clean the screen

or other components. Do not use any ammonia-based cleaners on the screen. Use of other products or methods may cause damage to components.

Screen

NOTE

Do not use any chemical cleaners or chemical containing wipes or cloths. These can cause damage to the screen surface.

Gently clean the display glass surface with a clean, dry microfiber cloth. Prior to cleaning it is suggested to remove any deposits of visible dust, dirt, sand particles with a gentle stream of compressed air. Cleaning the display glass in the presence of above can create scratches.

Cleaning the Radio

Spray a light amount of HARLEY GLOSS on a MICROFIBER DETAILING CLOTH. Be careful to gently remove any sediments without rubbing them into the screen. Apply circular motions from the center and outwards. Use a dry MICROFIBER DETAILING CLOTH to dry the screen. Repeat the process as necessary.

NOTE

Do not use any screen enhancing chemicals or products. These can damage the screen surface.

170 After Riding

Speaker Care

If a haze develops on speakers with a protective grille, use HARLEY SEAT, SADDLEBAG, AND TRIM CLEANER and a SOFTCLOTH or SOFT DETAILING PAD to clean. Do not apply wax or any other similar products on speaker grilles.

Do not use compressed or forced air on speakers.

Vehicles with saddlebag speakers are designed to prevent water intrusion and to allow water to drain during washing or riding in all weather. To remove any standing water from saddlebag speakers, open the saddlebags and gently shake any remaining water from the speakers.

FAIRING SPLITSTREAM VENT CARE

Keep the vent free of foreign objects. Periodically clean the vent to remove dirt, bugs and leaves.

1. Using mild soapy water and a soft brush, remove dirt, leaves and bugs from vent.

EXHAUST CARE

Allow exhaust components to cool before cleaning.

For chrome exhaust surfaces, apply Boot Mark Remover to remove boot marks, melted plastic or asphalt resin. Allow the gel to set for a few minutes, scrape off the melted material, and rinse clean.

For black-coated exhaust surfaces, apply Wheel & Tire Cleaner while motorcycle is wet during washing. Wipe or scrub exhaust surfaces and rinse clean.

NOTE

There is no warranty on exhaust pipes and mufflers with regard to any discoloration. Blueing is caused by tuning characteristics, cam timing, over-heating, and so on. It is not caused by defective manufacturing.

WHEEL CARE

Wheels can corrode or be cosmetically damaged if they are not properly cleaned, polished and preserved. Cleaning and sealing wheels with the proper treatment guards against

pitting, corrosion, spots and stains. Harley-Davidson recommends that wheels be cared for weekly. Corrosion to wheels is not considered a defect in materials or workmanship.

NOTE

Bare aluminum wheels do not have a protective coating and corrode unless properly treated. Apply BARE ALUMINUM WHEEL PROTECTANT when purchasing the motorcycle and at least twice per year to prevent cosmetic damage.

Keep wheels clean from harsh chemicals, acid-based wheel cleaners, salt and accumulated brake dust. After washing wheels with WHEEL & TIRE CLEANER, use the polish and sealing products according to the type of wheels. Refer to Table 41.

Table 41. Wheel Polish and Sealing Products

WHEELS	PRODUCT	DESCRIPTION
Anodized	GRAPHENE	Cleans surface, removes fine scratches. Provides a breathable sealant against acid, chemicals, salt and brake dust.
	GLOSS DETAILER	Seals and protects against harsh chemicals, salt and other sediments to prevent corrosion.

Table 41. Wheel Polish and Sealing Products

WHEELS	PRODUCT	DESCRIPTION
Chrome	CHROME CLEAN & SHINE	Non-abrasive cleaner to brighten chrome wheels.
	GLOSS DETAILER	Seals and protects against harsh chemicals, salt and other sediments to prevent oxidation.
Polished and bare aluminum or stainless steel	BARE METAL POLISH ⁽¹⁾	Microabrasive polish to refurbish polished wheels. Do not use on chrome.
<i>(1) DO NOT use BARE METAL POLISH on coated aluminum wheels, protective coating will be removed.</i>		

STORING MOTORCYCLE

If the motorcycle will not be operated for several months, take steps to protect the motorcycle. Always protect parts against corrosion, preserve the battery and prevent the build-up of gum and varnish in the fuel before storage.

Make a list of everything you do and fasten it to a handlebar grip. When you take the motorcycle out of storage, this list is your reference/checklist to get your motorcycle in operating condition.

▲ WARNING

Do not store motorcycle with gasoline in tank within the home or garage where open flames, pilot lights, sparks or electric motors are present. Gasoline is extremely flammable and highly explosive, which could result in death or serious injury. (00003a)

1. Fill fuel tank and add a gasoline stabilizer. Use one of the commercially available gasoline stabilizers and follow the manufacturer's instructions.
2. Warm motorcycle to operating temperature. Change oil and turn engine over to circulate the new oil. See MAINTENANCE AND LUBRICATION > CHANGE OIL AND OIL FILTER (Page 179).
3. Prepare battery for storage. See SERVICE PROCEDURES > BATTERY MAINTENANCE (Page 209).
4. To protect the body panels, engine, chassis and wheels from corrosion, follow the cosmetic care procedures before storage. See AFTER RIDING > CLEANING AND GENERAL CARE (Page 161).

5. Cover the motorcycle with a material such as light canvas that breathes. Plastic materials that do not breathe promote condensation and corrosion.



NOTES



BREAK-IN MAINTENANCE

NOTE

The performance of new motorcycle initial service is required to keep your new motorcycle warranty in force and for proper emissions system operation.

After a new motorcycle has been ridden 1000 mi (1,600 km), visit an authorized Harley-Davidson dealer for initial service. Refer to SERVICE INTERVALS AND RECORDS > SERVICE RECORDS (Page 253).

DISPOSAL AND RECYCLING

Help protect our environment! Many communities maintain facilities for recycling used fluids, plastics and metals. Dispose of or recycle used oil, lubricants, fuel, coolant, brake fluid and batteries in accordance with local regulations. Many Harley-Davidson parts and accessories are made of plastics and metals which can also be recycled.

ENGINE LUBRICATION: SYNTHETIC OIL

Engine oil is a major factor in the performance and service life of the engine. Use the proper grade of oil for the lowest temperature expected before the next oil change. Your authorized dealer has the proper oil to suit your requirements. Refer to Table 42.

NOTE

Model year 2020 and newer CVO models for the Brazil market are manufactured with H-D 360 conventional motor oil, unless on-product labeling indicates otherwise. Motorcycles equipped with SYN3 can be identified by a SYN3 label on the primary chaincase cover.

Motorcycles are shipped from the factory with SCREAMIN' EAGLE SYN3 FULL SYNTHETIC MOTORCYCLE LUBRICANT 20W50. If SYN3 is not available and addition of motor oil is required, the first choice would be to add GENUINE HARLEY-DAVIDSON H-D 360 MOTORCYCLE OIL 20W50 to the SYN3 for engine lubrication. Although H-D 360 is compatible with SYN3, we suggest the mixture of the fluids be changed as soon as possible.

To switch lubricant to H-D 360, completely drain the SYN3 before filling with H-D 360. A residual amount of fluid will remain. It is not required to flush out the residual fluid.

If SYN3 or H-D 360 is not available, a third option is to add an acceptable diesel engine oil. Acceptable diesel engine oil designations include: CH-4, CI-4, and CJ-4. The preferred viscosities for diesel engine oils in descending order are: 20W50, 15W40, and 10W40.

While you may elect to use other oils not listed above, Harley-Davidson is not obligated to pay for damage resulting from the use of non-genuine oil or unapproved alternatives.

If using a mixture of oils, it is recommended to change to SYN3 or H-D 360, or approved alternatives at your first opportunity.

NOTICE

Do not switch lubricant brands indiscriminately because some lubricants interact chemically when mixed. Use of inferior lubricants can damage the engine. (00184a)

Table 42. Recommended Engine Oils

TYPE	VISCOSITY	LOWEST AMBIENT TEMPERATURE	COLD-WEATHER STARTS BELOW 50 °F (10 °C)
Screamin' Eagle SYN3 Full Synthetic Motorcycle Lubricant	SAE 15W50	Above 30.2 °F (-1 °C)	Excellent
Screamin' Eagle SYN3 Full Synthetic Motorcycle Lubricant	SAE 20W50	Above 30.2 °F (-1 °C)	Excellent
Genuine Harley-Davidson H-D 360 Motorcycle Oil	SAE 20W50	Above 39.2 °F (4 °C)	Good
Genuine Harley-Davidson H-D 360 Motorcycle Oil	SAE 50	Above 60.8 °F (16 °C)	Poor
Genuine Harley-Davidson H-D 360 Motorcycle Oil	SAE 60	Above 80.6 °F (27 °C)	Poor

CHECK ENGINE OIL LEVEL

▲ CAUTION

Prolonged or repeated contact with used motor oil may be harmful to skin and could cause skin cancer. Promptly wash affected areas with soap and water. (00358b)

NOTICE

Do not overfill oil. Doing so can result in oil carryover to the air cleaner leading to equipment damage and/or equipment malfunction. (00190b)

NOTE

Check engine oil level at each complete fuel refill.

Oil Level Cold Check

1. Place vehicle on level ground resting on the jiffy stand.

NOTE

Oil level on a cold engine should never be above the midway point.

2. See Figure 82. Check engine oil level.
 - a. Remove filler plug/dipstick.
 - b. Wipe off the dipstick.

- c. Insert the dipstick and tighten into the fill spout.
 - d. Remove filler plug/dipstick.
 - e. See Figure 83. Check oil level. The correct cold oil level is midway (2) between the ADD QT (1) and FULL HOT (3) marks on the dipstick.
3. If oil level is at or below the ADD QT mark, add only enough oil to bring the level to the ADD QT mark.
 4. Start and idle engine on jiffy stand for two minutes. Turn off engine.
 5. Check oil level. Add only enough to bring level midway between the ADD QT (1) and FULL HOT (3).

Oil Level Hot Check

NOTICE

Do not allow hot oil level to fall below Add/Fill mark on dipstick. Doing so can result in equipment damage and/or equipment malfunction. (00189a)

NOTE

Perform engine oil level hot check only with engine oil at normal operating temperature.

1. Ride motorcycle until engine oil reaches at least 200 °F (93 °C) or higher.

2. Allow engine to idle for 1-2 minutes on jiffy stand. Turn off engine.
3. See Figure 82. Check oil level.
 - a. Remove filler plug/dipstick.
 - b. Wipe off the dipstick.
 - c. Insert the dipstick and tighten into the fill spout.
 - d. Remove filler plug/dipstick.
 - e. See Figure 83. Check oil level. Oil level must register between the ADD QT and FULL HOT marks on the dipstick.
4. If oil level is at or below the ADD QT mark, add only enough oil to bring the level to the FULL HOT mark. Do not overfill.

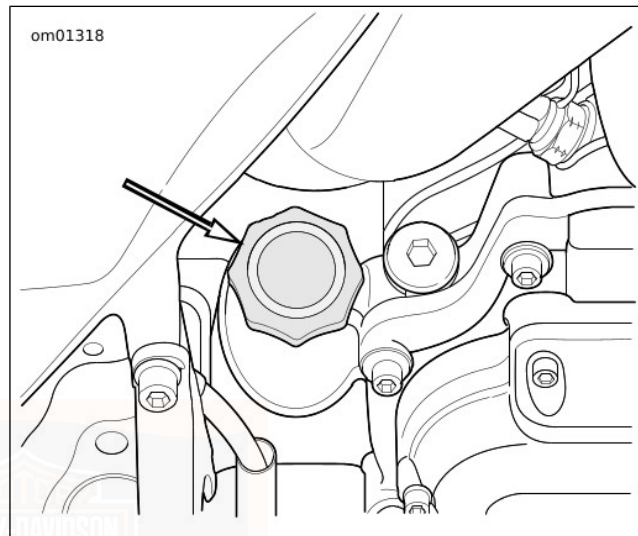

Figure 82. Engine Oil Filler Cap

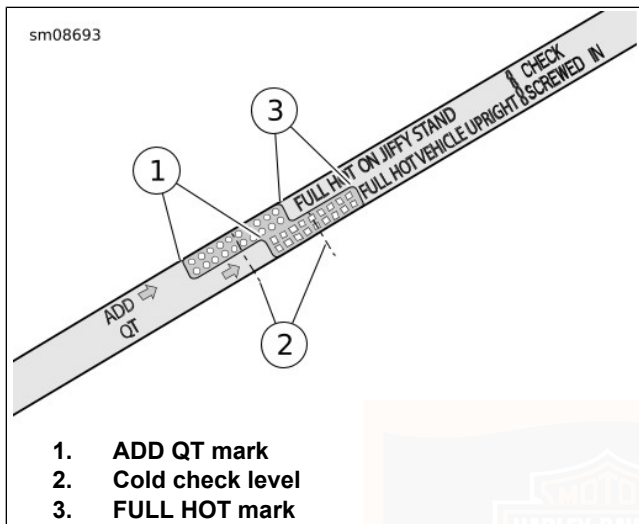

Figure 83. Engine Oil Dipstick

CHANGE OIL AND OIL FILTER

⚠ WARNING

Be sure that no lubricants or fluids get on tires, wheels or brakes when changing fluid. Traction can be adversely affected, which could result in loss of control of the motorcycle and death or serious injury. (00047d)

NOTICE

Do not switch lubricant brands indiscriminately because some lubricants interact chemically when mixed. Use of inferior lubricants can damage the engine. (00184a)

⚠ CAUTION

Prolonged or repeated contact with used motor oil may be harmful to skin and could cause skin cancer. Promptly wash affected areas with soap and water. (00358b)

- Change engine oil at the first 1000 mi (1,600 km) for a **new** engine. After the initial service, change oil at regular intervals in normal service at warm or moderate temperatures. Refer to SERVICE INTERVALS AND RECORDS > SERVICE RECORDS (Page 253).
 - Change oil at more frequent intervals in cold weather or severe operating conditions. See Winter Lubrication in MAINTENANCE AND LUBRICATION > LOW TEMPERATURE LUBRICATION (Page 182).
1. Run motorcycle until engine is at normal operating temperature. Turn off engine.
 2. Remove filler plug/dipstick.

3. Drain engine oil.
 - a. See Figure 85. Locate engine oil drain plug and O-ring (1).
 - b. See Figure 84. Rotate engine oil drain plug counterclockwise to open (2) position.
 - c. Replace O-ring on engine oil drain plug.
 - d. Allow oil to drain completely.

NOTE

Use P&A Oil Catcher (Part No. 62700199) or equivalent to keep drain oil off crankcase when removing oil filter. Residual drain oil could falsely appear as a crankcase oil leak at a later time.

4. Remove the oil filter using oil filter wrench and hand tools. Do not use with air tools.
Special Tool: OIL FILTER WRENCH (94863-10)
Special Tool: OIL FILTER WRENCH (94686-00)
5. Clean the oil filter mount flange.
6. Clean any residual oil for crankcase and transmission housing.

7. See Figure 86. Install **new** oil filter.
 - a. Lubricate gasket with a thin film of clean engine oil.
 - b. Install **new** oil filter.
 - c. Hand-tighten oil filter one-half to three-quarters of a turn after gasket first contacts filter mounting surface. Do NOT use oil filter wrench for installation.
8. Install engine oil drain plug and **new** O-ring.

NOTE

Use the proper grade of oil for the lowest temperature expected before the next oil change. Refer to Table 42 for recommended oil.

- a. See Figure 84. Place engine oil drain plug in position open (2).
 - b. Rotate engine oil drain plug clockwise to position close (1).
9. Add an initial volume of engine oil. Refer to Table 43.

Table 43. Initial Oil Fill

ITEM	QUANTITY
Engine oil initial fill	4.0 qt (3.8 L)

10. Verify proper oil level. See MAINTENANCE AND LUBRICATION > CHECK ENGINE OIL LEVEL (Page 177).
 - a. Perform engine oil level **cold check**.
 - b. Start engine and carefully check for oil leaks around drain plug and oil filter.
 - c. Perform engine oil level **hot check**.

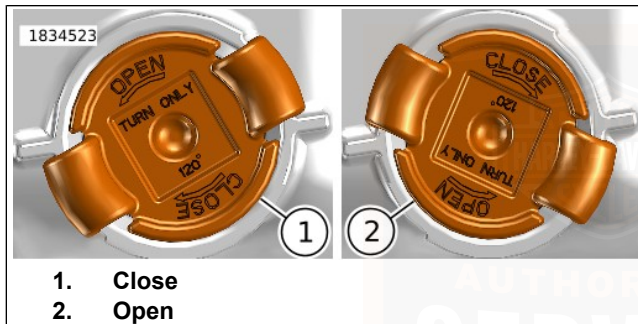

Figure 84. Drain Plug Orientation

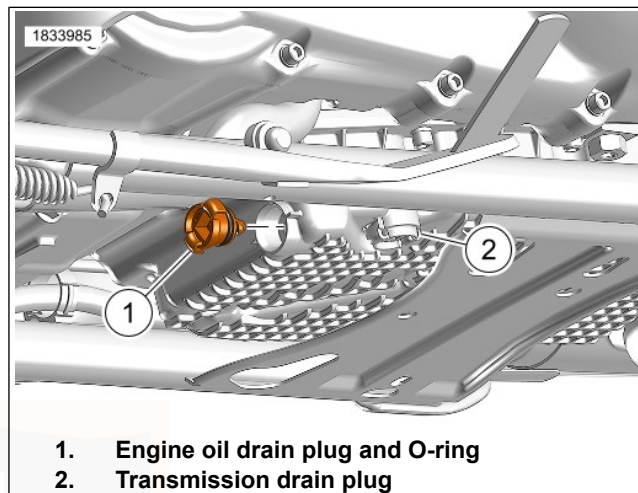

Figure 85. Oil Drain Plug

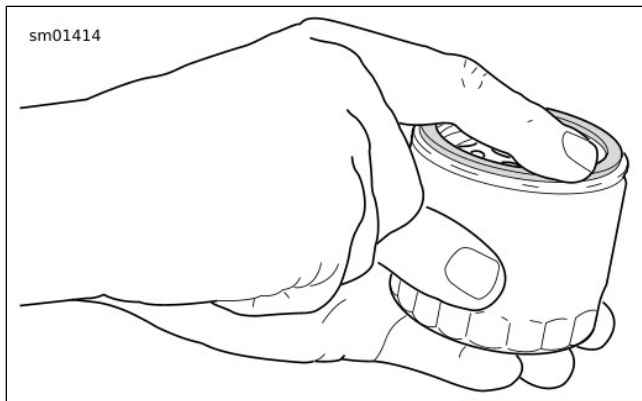

Figure 86. Lubricating New Oil Filter Gasket

LOW TEMPERATURE LUBRICATION

Change engine oil often in colder climates. If motorcycle is frequently ridden less than 15 mi (24 km), in ambient temperatures below 60 °F (16 °C), reduce oil change intervals to 1500 mi (2,400 km).

NOTE

Lower ambient temperatures require more frequent oil changes.

Water vapor is a normal by-product of combustion . During cold-weather operation, some water vapor condenses to liquid

form on the cool surfaces inside the engine. In freezing weather, this water becomes slush or ice. If the engine is not warmed to operating temperature, accumulated slush or ice blocks the oil lines and causes engine damage. Over time, water will accumulate, mix with the engine oil and form a sludge that is harmful to the engine.

If the engine is allowed to warm to normal operating temperature, most of the water evaporates and exits through the crankcase breather.

CHECK TRANSMISSION LUBRICANT

NOTE

Check transmission fluid with the motorcycle at ambient temperature. Inspect transmission dipstick O-ring. Replace if necessary.

1. Park motorcycle on a level surface on jiffy stand.
2. See Figure 87. Remove transmission filler plug/dipstick. Wipe dipstick clean.
3. Install filler plug/dipstick until O-ring contacts the case. Do not tighten.

4. See Figure 88. Remove filler plug/dipstick. Check lubricant level on dipstick. Proper oil level is between the Add (A) (1) and Full (F) (2) marks.
5. If lubricant level is low, add recommended Harley-Davidson lubricant to bring level to between the A mark and the F marks. Refer to Table 44.
6. Install filler plug/dipstick. Tighten to specification.
Torque: 25–75 **in-lbs** (2.8–8.5 N·m) *Transmission filler plug/dipstick*

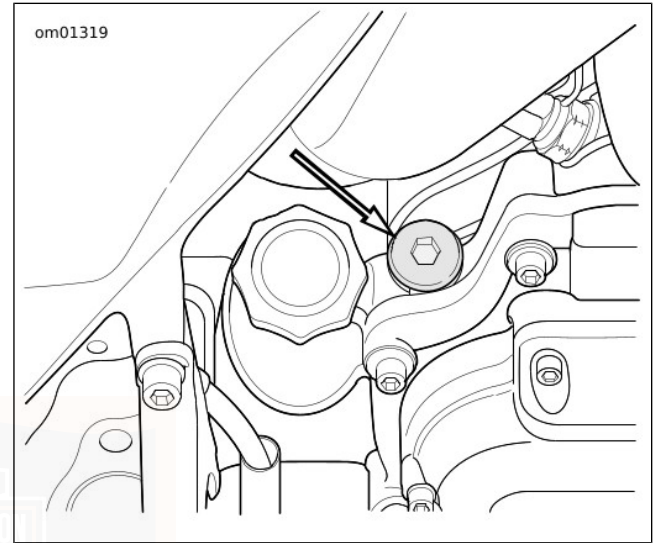
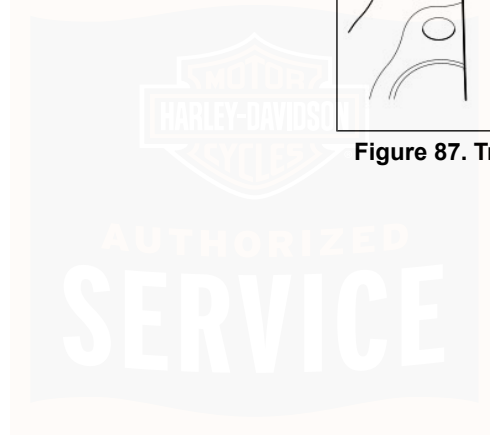

Figure 87. Transmission Filler Plug/Dipstick Location



1441573

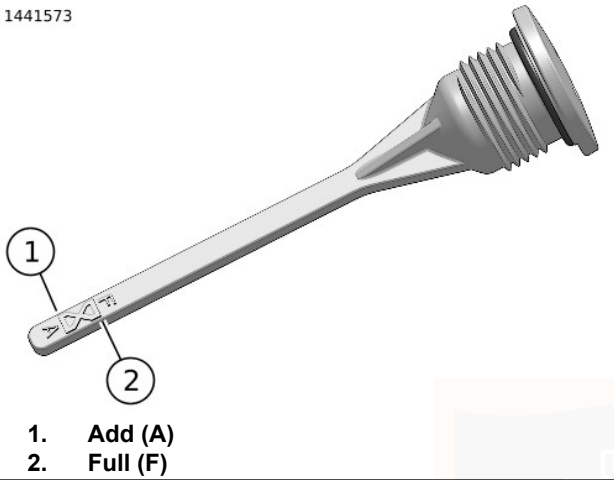

Figure 88. Transmission Lubricant Level

Table 44. Recommended Lubricant

LUBRICANT	REFILL QTY.*	
	fl oz	L
SCREAMIN' EAGLE SYN3 FULL SYN- THETIC MOTORCYCLE LUBRICANT 20W50 or FORMULA+ TRANSMISSION AND PRIMARY CHAIN LUBRICANT	28	0.83
*Approximate. Check level. Add lubricant to bring level within specification.		

CHANGE TRANSMISSION LUBRICANT

1. See Figure 88. Remove transmission filler plug/dipstick.

⚠ WARNING

Be sure that no lubricants or fluids get on tires, wheels or brakes when changing fluid. Traction can be adversely affected, which could result in loss of control of the motorcycle and death or serious injury. (00047d)

2. Drain transmission oil.
 - a. See Figure 90. Locate transmission oil drain plug and O-ring (1).

- b. See Figure 89. Rotate transmission oil drain plug counterclockwise to open (2) position.
 - c. Remove drain plug.
 - d. Allow oil to drain completely.
3. Clean and inspect drain plug and O-ring.

NOTICE

Do not over-tighten filler or drain plug. Doing so could result in a lubricant leak. (00200b)

4. Install transmission drain plug with O-ring.

NOTE

Inspect drain plug O-ring. Replace, if damaged. Lubricate O-ring with transmission lubricant.

- a. See Figure 89. Place transmission oil drain plug in position open (2).
- b. Rotate transmission oil drain plug clockwise to position close (1).

5. Fill the transmission with recommended Harley-Davidson lubricant. Refer to Table 44.

Volume: 28 fl oz (0.83 L)

6. Check lubricant level. Add enough lubricant to bring the level between the add (A) and full (F) marks. See Figure 88.

7. Install filler plug/dipstick. Tighten.

Torque: 25–75 **in-lbs** (2.8–8.5 N·m) *Transmission filler plug/dipstick*

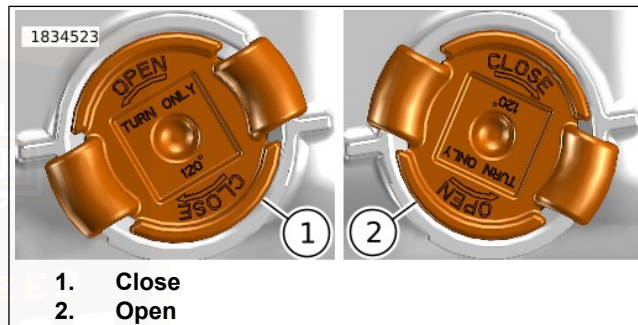

Figure 89. Drain Plug Orientation

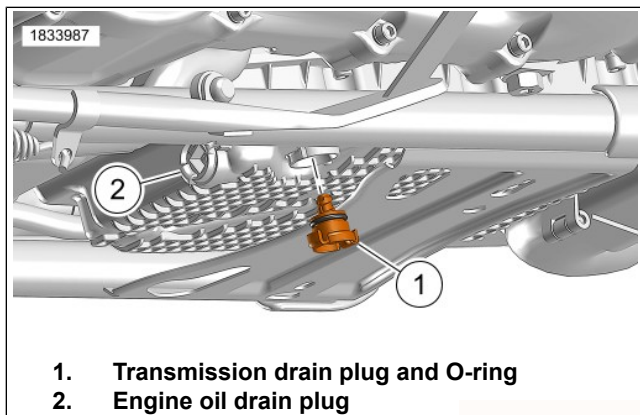

Figure 90. Transmission Drain Plug

PRIMARY CHAINCASE LUBRICATION: SYNTHETIC OIL

Lubrication is a major factor in the performance and service life of the clutch components. Use the appropriate Harley-Davidson chaincase lubricant for all operating temperatures.

NOTE

Model year 2020 and newer CVO models for the Brazil market are manufactured with H-D 360 conventional motor oil, unless on-product labeling indicates otherwise. Motorcycles equipped

with SYN3 can be identified by a SYN3 label on the primary chaincase cover.

Your motorcycle comes equipped with SCREAMIN' EAGLE SYN3 FULL SYNTHETIC MOTORCYCLE LUBRICANT 20W50. If SYN3 is not available and addition of lubricant to the primary chaincase is required, the first choice would be to add FORMULA+ TRANSMISSION AND PRIMARY CHAINCASE LUBRICANT. Although FORMULA+ TRANSMISSION AND PRIMARY CHAINCASE LUBRICANT is compatible with SYN3, we suggest the mixture of the fluids be changed as soon as possible.

NOTE

For model specific information regarding the primary chaincase capacity, refer to the appropriate Service Manual or see a Harley-Davidson dealer.

CHANGE PRIMARY CHAINCASE LUBRICANT

1. Run motorcycle until engine is at normal operating temperature. Turn off engine.

▲ WARNING

Be sure that no lubricants or fluids get on tires, wheels or brakes when changing fluid. Traction can be adversely affected, which could result in loss of control of the motorcycle and death or serious injury. (00047d)

2. Secure motorcycle upright (not leaning on jiffy stand) on a level surface.
3. See Figure 91. Drain primary chaincase.
4. Clean drain plug magnet. If plug has excessive debris, inspect the condition of chaincase components.
5. Install drain plug and **new** O-ring. Tighten to 14–21 ft-lbs (19–28.5 N·m).

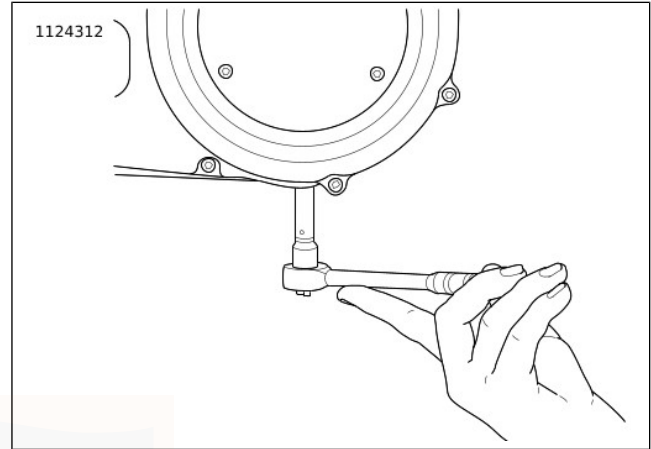

Figure 91. Removal/Installation of Chaincase Drain Plug

6. See Figure 93. Remove screws (3) and clutch inspection cover (2).
7. Remove seal (1). Wipe oil from groove in chaincase cover and mounting surface.

NOTICE

Do not overfill the primary chaincase with lubricant. Overfilling can cause rough clutch engagement, incomplete disengagement, clutch drag and/or difficulty in finding neutral at engine idle. (00199b)

8. Add lubricant.
 - a. Pour specified amount of SCREAMIN' EAGLE SYN3 FULL SYNTHETIC MOTORCYCLE LUBRICANT 20W50 through clutch inspection cover opening. Refer to Table 45.
 - b. See Figure 92. Proper level is approximately at bottom of pressure plate OD.

Table 45. Primary Chaincase Lubricant

ITEM	DRY FILL ⁽²⁾		WET FILL ⁽³⁾	
	Oz	L	Oz	L
Amount ⁽¹⁾	34	1.0	30	0.9

(1) Amount is approximate. Fill to bottom of pressure plate OD with vehicle upright.
(2) Cover was removed and installed.
(3) Lubricant was drained through the drain plug only.

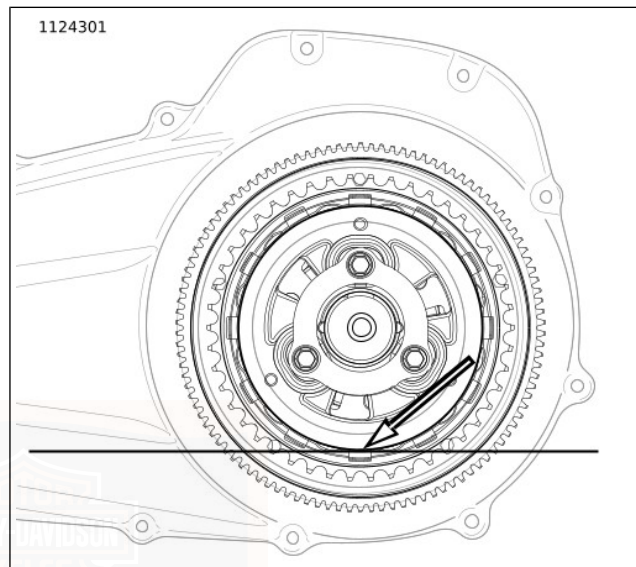

Figure 92. Primary Lubricant Level

9. Install clutch inspection cover and **new** seal:
 - a. Thoroughly wipe all lubricant from cover mounting surface and groove in chaincase cover.

- b. See Figure 93. Position **new** seal (1) in groove in clutch inspection cover (2). Press each of the nubs on seal into the groove.
- c. Secure clutch inspection cover (2) with screws with captive washers (3).
- d. See Figure 94. Tighten in sequence shown to 84–108 **in-lbs** (9.5–12.2 N·m).

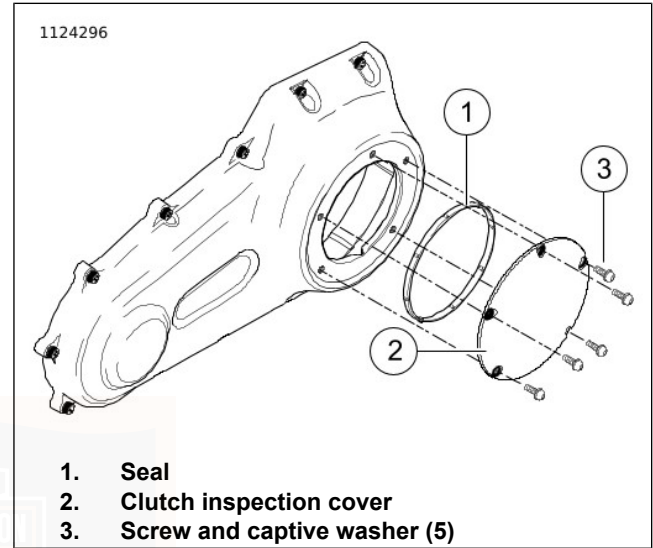
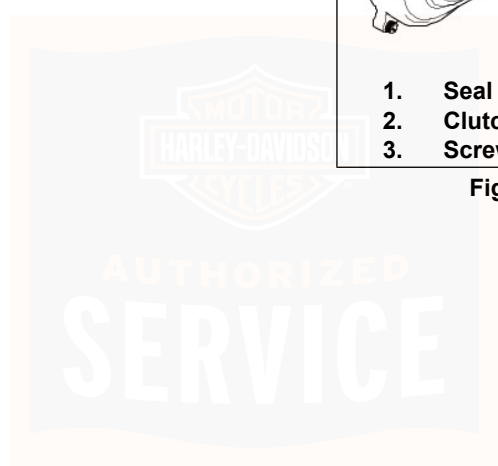

Figure 93. Clutch Cover (Typical)



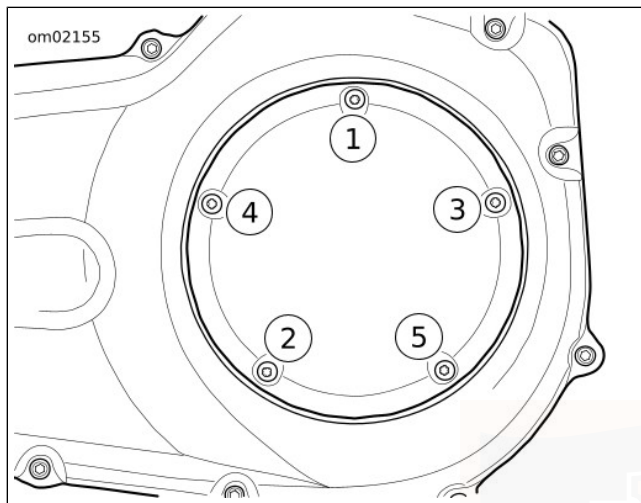

Figure 94. Clutch Cover Tightening Sequence

BRAKES

⚠ WARNING

DOT 4 brake fluid absorbs moisture from the atmosphere over time, changing the properties of the fluid. Check brake fluid moisture content at every service interval or annually (whichever comes first). Flush and replace the brake fluid every two years, or sooner if moisture content is 3% or greater. Failure to flush and replace fluid can adversely affect braking, which could result in death or serious injury. (06304b)

To ensure the brake system is performing to design, check the moisture content of the brake fluid at every service interval or at least annually using a DOT 4 brake fluid moisture tester (part number HD-48497-A or equivalent) following the instructions included with the tool. Flush DOT 4 fluid every 2 years or sooner if the brake system fluid test shows moisture content is 3% or greater.

Harley-Davidson recommends using Harley-Davidson Platinum Label DOT 4 Brake Fluid because of its superior moisture and corrosion inhibiting properties.

Brake Fluid

⚠ WARNING

Clean reservoir filler cap or cover before removing. Use only DOT 4 brake fluid from a sealed container. Contaminated fluid can adversely affect braking, which could result in death or serious injury. (13720a)

⚠ WARNING

Contact with DOT 4 brake fluid can have serious health effects. Failure to wear proper skin and eye protection could result in death or serious injury.

- If inhaled: Keep calm, remove to fresh air, seek medical attention.
- If on skin: Remove contaminated clothing. Rinse skin immediately with plenty of water for 15-20 minutes. If irritation develops, seek medical attention.
- If in eyes: Wash affected eyes for at least 15 minutes under running water with eye lids held open. If irritation develops, seek medical attention.
- If swallowed: Rinse mouth and then drink plenty of water. Do not induce vomiting. Contact Poison Control. Immediate medical attention required.
- See Safety Data Sheet (SDS) for more details available at sds.harley-davidson.com

(00240e)

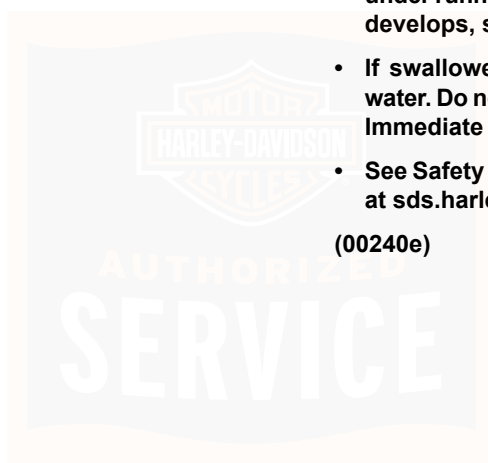

NOTICE

DOT 4 brake fluid will damage painted and body panel surfaces it comes in contact with. Always use caution and protect surfaces from spills whenever brake work is performed. Failure to comply can result in cosmetic damage. (00239c)

- If DOT 4 brake fluid contacts painted surfaces, IMMEDIATELY flush area with clear water.

NOTICE

Do not allow dirt or debris to enter the master cylinder reservoir. Dirt or debris in the reservoir can cause improper operation and equipment damage. (00205c)

NOTE

- *If the brake system is not leaking, there should never be a need to add fluid. If the fluid level is low, the pads are probably worn. By replacing the pads, the fluid level will return to its normal level.*
- *Use only DOT 4 brake fluid and replace the brake fluid every two years or sooner if moisture content is 3% or greater. See a Harley-Davidson dealer.*

Inspect brake fluid level and check brake pads and discs for wear at proper intervals. Refer to SERVICE INTERVALS AND RECORDS > SERVICE RECORDS (Page 253).

1. Place vehicle on a flat level surface.
 - a. **Front brake:** Level the master cylinder by turning the handlebar and/or standing the motorcycle upright (not leaning on jiffy stand).
 - b. **Rear brake:** Position the motorcycle so the master cylinder reservoir is level.
2. See Figure 95. View reservoir sight glass. Fluid level must be at or above the minimum mark on glass. If fluid level is below minimum mark, see a Harley-Davidson dealer.
3. Verify front brake hand lever and rear brake foot pedal have a firm feel when applied. If brakes are not firm, the brake system must be bled. See a Harley-Davidson dealer.

1739249

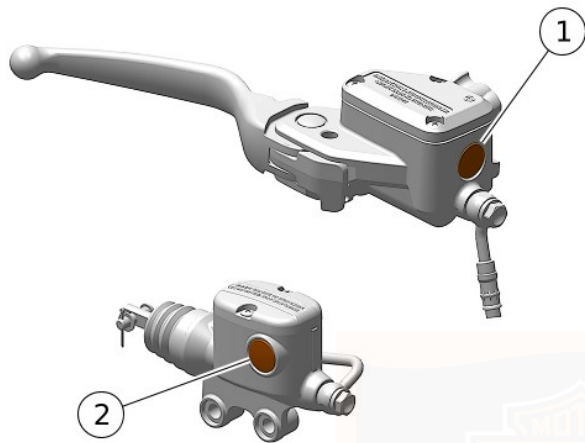

1. Front master cylinder reservoir
2. Rear master cylinder reservoir

Figure 95. Sight Glass Minimum Marks

Brake Pads

⚠ WARNING

Inspect brake pads for wear at service maintenance intervals. If you ride under adverse conditions (steep hills, heavy traffic, etc.), inspect more frequently. Excessively worn brake pads can lead to brake failure, which could result in death or serious injury. (00052a)

⚠ WARNING

Always replace brake pads in complete sets for correct and safe brake operation. Improper brake operation could result in death or serious injury. (00111a)

⚠ WARNING

Brakes are a critical safety component. Contact a Harley-Davidson dealer for brake repair or replacement. Improperly serviced brakes can adversely affect brake performance, which could result in death or serious injury. (00054a)

⚠ WARNING

Perform routine scheduled brake maintenance. Lack of maintenance at recommended intervals can adversely affect brake performance, which could result in death or serious injury. (00055a)

▲ WARNING

Be sure wheel and brake caliper are aligned. Riding with a misaligned wheel or brake caliper can cause the brake disc to bind and lead to loss of control, which could result in death or serious injury. (00050a)

Harley-Davidson has provided your new motorcycle with the most optimum brake pad friction material available. It is selected to give the best performance possible under dry, wet and high operating temperature conditions. It exceeds all regulatory requirements currently in effect. However, during some braking conditions you can hear a brake noise. This noise is normal for this friction material.

Table 46. Minimum Brake Pad Friction Material Thickness

Brake Pads	Minimum Thickness
Front	0.020 in (0.5 mm)
Rear	0.016 in (0.4 mm)

1. See Figure 96. Check the brake disc as it spins. The disc should run true in the brake caliper.
2. Measure the thickness of the brake pad friction material. The pads do not necessarily wear evenly. Check each pad. The grooves on the brake pads are no longer visible when the pads are near the end of service life.

3. Replace brake pads before friction material reaches minimum thickness. Always replace brake pads in pairs. See a Harley-Davidson dealer. Refer to Table 46.

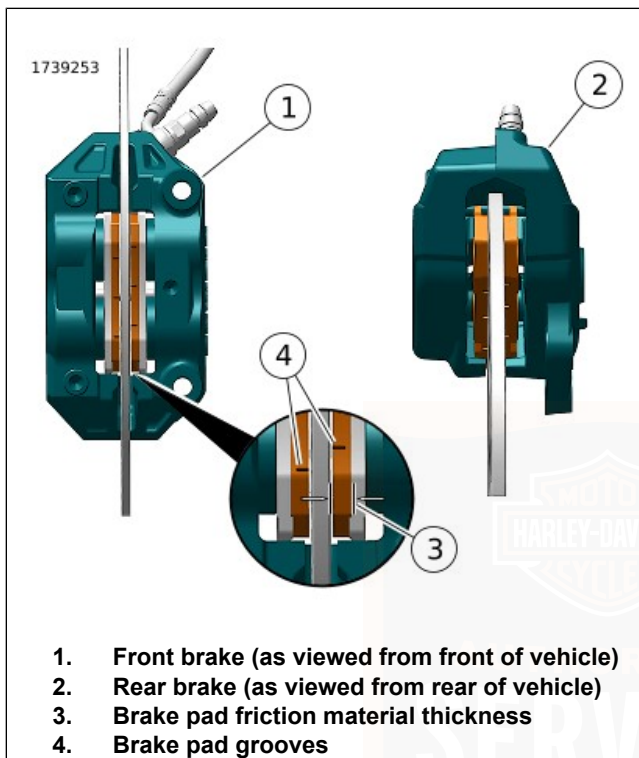

1. Front brake (as viewed from front of vehicle)
2. Rear brake (as viewed from rear of vehicle)
3. Brake pad friction material thickness
4. Brake pad grooves

Figure 96. Brake Pad Friction Material

COOLING SYSTEM

⚠ WARNING

Coolant mixture contains toxic chemicals, which may be fatal if swallowed. If swallowed, do not induce vomiting; call a physician immediately. Use in a well ventilated area. Irritation to skin or eyes can occur from vapors or direct contact. In case of skin or eye contact, flush thoroughly with water and go to hospital, if necessary. Dispose of used coolant according to federal, state and local regulations. (00092a)

⚠ CAUTION

At operating temperature, radiators and oil coolers contain hot fluids. Contact with a radiator or oil cooler can result in minor or moderate burns. (00141b)

NOTICE

Use only Genuine Harley-Davidson Extended Life Antifreeze and Coolant. Use of other coolants/mixtures may lead to motorcycle damage. (00179c)

GENUINE HARLEY-DAVIDSON EXTENDED LIFE ANTIFREEZE AND COOLANT is pre-diluted and ready to use full strength. It provides temperature protection to -34 °F (-36.7 °C). DO NOT add water.

NOTICE

De-ionized water must be used with the antifreeze in the cooling system. Hard water can cause scale accumulation in water passages which reduces cooling system efficiency, leading to overheating and motorcycle damage. (00195b)

If GENUINE HARLEY-DAVIDSON EXTENDED LIFE ANTIFREEZE AND COOLANT is unavailable, a mixture of de-ionized water and ethylene glycol-based antifreeze may be used. At the first opportunity, change back to GENUINE HARLEY-DAVIDSON EXTENDED LIFE ANTIFREEZE AND COOLANT.

Checking Coolant Level

NOTE

Check coolant level with engine cold and motorcycle on level ground.

NOTE

Use a light source from opposite side of reservoir to view coolant level.

1. See Figure 97. Check that coolant level in reservoir is between the coolant maximum level mark (1) and the coolant cold level mark (3).

NOTE

- Do not remove the reservoir pressure cap (2).
 - If the coolant reservoir is empty when the engine is cold, inspect the system for leaks. Repair as needed. Fill system with coolant and perform bleed procedure. See a Harley-Davidson dealer for service.
2. If level is below coolant cold level mark (3) line on tank, add GENUINE HARLEY-DAVIDSON EXTENDED LIFE ANTIFREEZE AND COOLANT until fluid level reaches, or is slightly above the "COLD" line.

Add Coolant

1. Allow engine to cool.
2. Remove reservoir from clip.
3. See Figure 97. Remove reservoir pressure cap (2).
4. Hold reservoir vertical.
5. Add GENUINE HARLEY-DAVIDSON EXTENDED LIFE ANTIFREEZE AND COOLANT until fluid level reaches, or is slightly above the coolant cold level mark (3).
6. Install reservoir pressure cap.
7. Replace reservoir in clip.

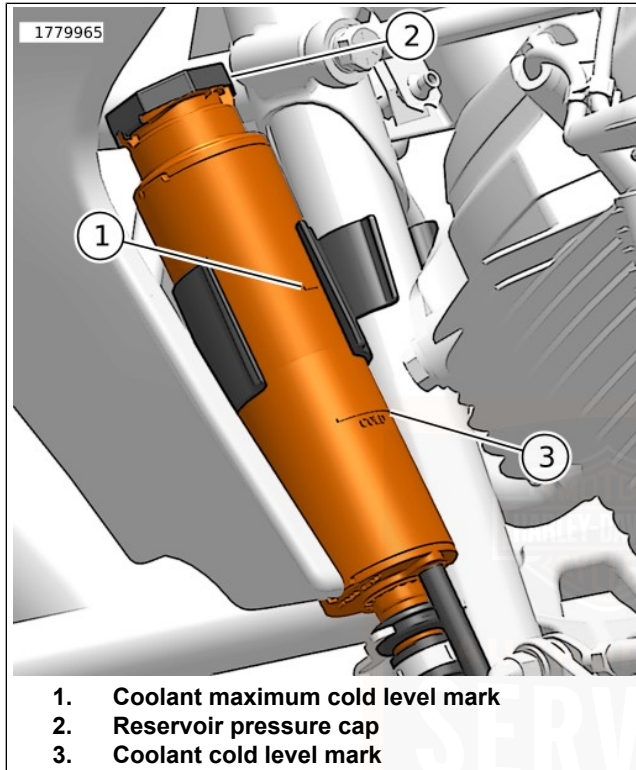

Figure 97. Coolant Level

Clean Radiator

NOTICE

Clean the inlet surface of the radiator regularly. Leaves and other debris can collect on the radiator surface and degrade radiator performance which could lead to overheating and motorcycle damage. (00197d)

1. See Figure 98. Remove chin spoiler.
 - a. With motorcycle on jiffy stand, turn forks to the left.
 - b. Pull chin spoiler (1) straight forward.
2. Clean debris from radiator (3) fins.
3. Install chin spoiler.
 - a. With motorcycle on jiffy stand, turn forks to the left.
 - b. Lubricate barbed studs on chin spoiler.
 - c. Align barbed studs on chin spoiler with grommets (3).
 - d. Push in to secure.

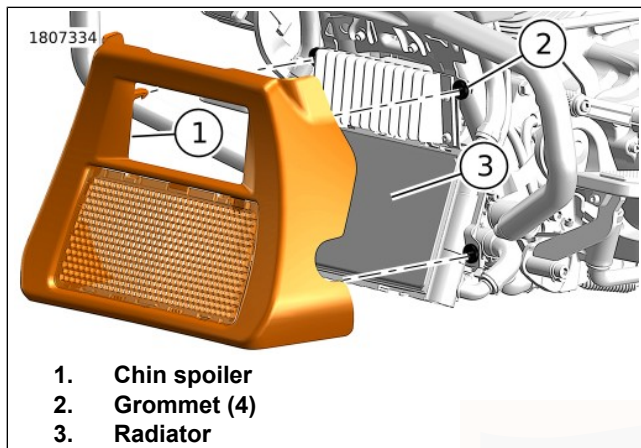

Figure 98. Chin Spoiler

Checking Coolant Freeze Point

See a HARLEY-DAVIDSON dealer for coolant freeze point test.

CHECK DRIVE BELT DEFLECTION

NOTE

Always use *BELT TENSION GAUGE (PART NUMBER: HD-35381-A)* to measure belt deflection. Failure to use tension gauge may cause under-tensioned belts. Loose belts can fail

due to "ratcheting" (jumping a tooth) which causes tensile cord crimping and breakage.

Check deflection:

- With transmission in neutral.
- With motorcycle at ambient temperature.
- With motorcycle upright or on jiffy stand with rear wheel on the ground.
- With the vehicle unladen: no rider, no luggage and empty saddlebags.

⚠ WARNING

To prevent accidental vehicle start-up, which could cause death or serious injury, remove main fuse before proceeding. (00251b)

1. Disarm security system. Remove main fuse. See SERVICE PROCEDURES > FUSES (Page 217).
2. Shift transmission to neutral.

NOTE

When adjusting a **new** belt, rotate rear wheel a few revolutions prior to setting the tension.

3. See Figure 99. Measure belt deflection using:
Special Tool: BELT TENSION GAUGE (HD-35381-A)
 - a. Slide O-ring (4) to zero mark (3).
 - b. **Models equipped with belt deflection window:**
Fit belt cradle (2) against bottom of drive belt in line with belt deflection window.
 - c. **All other models:** Fit belt cradle (2) against bottom of drive belt halfway between drive pulleys.
 - d. Press upward on knob (6) until O-ring slides down to 10 lb (4.54 kg) mark (5) and hold steady.

4. Measure belt deflection:

- a. **Models equipped with belt deflection window:**
See Figure 101. Measure belt deflection as viewed through belt deflection viewing window while holding gauge steady. Each deflection graduation is approximately 1/16 in (1.6 mm)
- b. **All other models:** See Figure 100. Measure amount of deflection (4) while holding gauge steady.

5. **NOTE**
Set to the lower (tightest) specification if the belt has less than 1,600 km (1000 mi).

Compare with specifications. Refer to Table 47. If not within specifications, see a Harley-Davidson dealer.

6. Install main fuse.

Table 47. Belt Deflection

MODELS	in	mm
All models	1/4-7/16	6.4-11.2

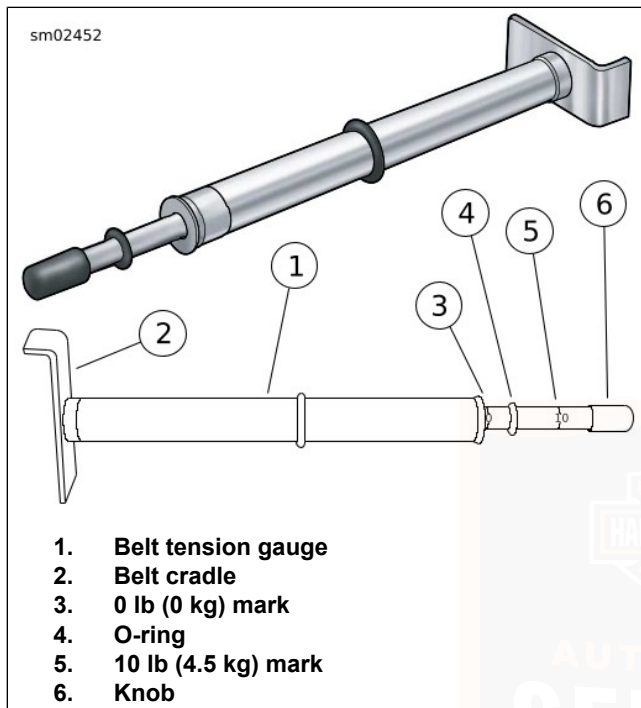

Figure 99. Belt Tension Gauge

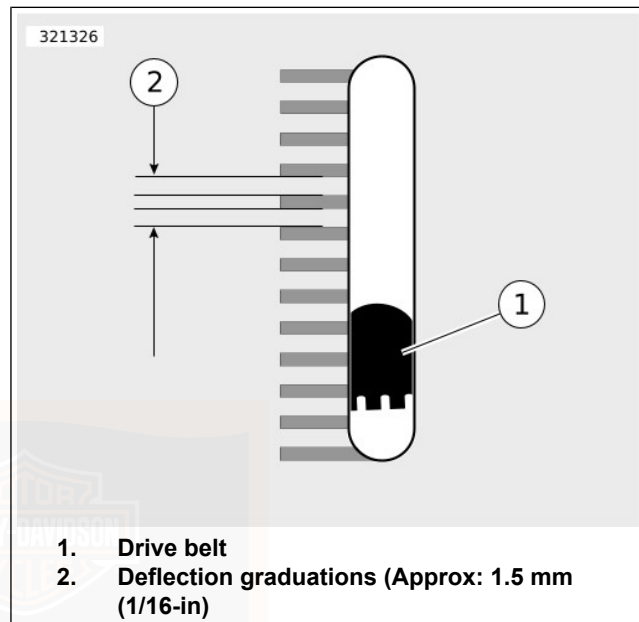

Figure 100. Belt Deflection Window

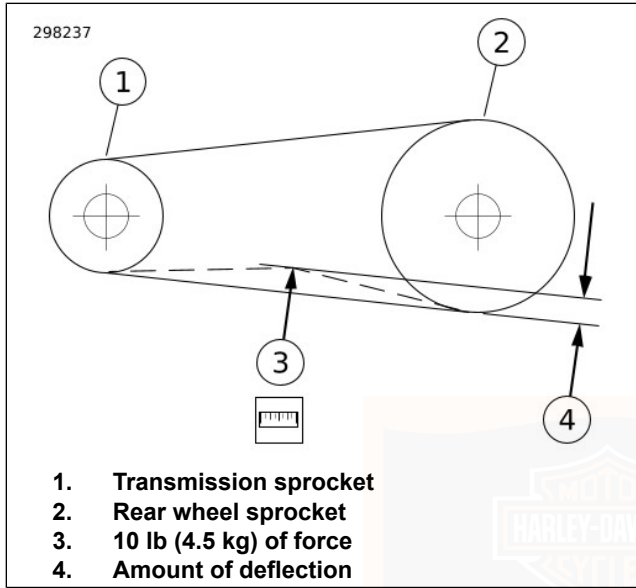

Figure 101. Checking Belt Deflection

MISCELLANEOUS LUBRICATION

Inspect and lubricate the following components according to the maintenance schedule. Refer to SERVICE INTERVALS AND RECORDS > SERVICE RECORDS (Page 253).

- Front brake lever pivot

- Clutch control hand lever pivot
- Foot shift lever pivot
- Rear brake lever pivot
- Hinges and latches (such as fuel door and footrests)
- Locks, as required
- Jiffy stand (use ANTI-SEIZE LUBRICANT)

Use HARLEY LUBE unless otherwise specified.

If motorcycle is operated on muddy or dusty roads, clean and lubricate more frequently.

MECHANICAL CLUTCH

NOTICE

The clutch control cable must be oiled and adjusted periodically to compensate for lining wear. Failure to oil and adjust the clutch control cable can result in equipment damage. (00203c)

Adjust the clutch control cable at specified intervals. Refer to SERVICE INTERVALS AND RECORDS > SERVICE RECORDS (Page 253).

If the clutch slips under load or drags when released, the control cable may need to be adjusted or clutch service may

need to be performed. See a Harley-Davidson dealer for service.

HYDRAULIC LIFTERS

The hydraulic lifters are self-adjusting. They automatically adjust length to compensate for engine expansion and valve mechanism wear. This keeps the valve mechanism free of lash when the engine is running.

When starting an engine which has been turned off even for a few minutes, the valve mechanism may be slightly noisy until the hydraulic units completely refill with oil. If at any time the valve mechanism becomes abnormally noisy, other than for a short period immediately after engine is started, it is an indication that one or more of the hydraulic units may not be functioning properly.

Always check the engine oil level first since normal circulation of oil through the engine is necessary for proper operation of the hydraulic lifters.

If engine oil is at the proper level, the lifters may not be functioning properly because of dirt in the oil supply passages leading to the lifter units. See a Harley-Davidson dealer for service.

CHECKING FOR EXHAUST LEAKS

Refer to SERVICE INTERVALS AND RECORDS > SERVICE RECORDS (Page 253) for all maintenance schedules.

1. Allow exhaust components to cool.
2. Check exhaust system for obvious signs of leakage such as carbon marks or marks at pipe joints.
 - a. Check for loose or missing fasteners.
 - b. Check for fractured pipe clamps or brackets.
 - c. Check for loose or fractured exhaust shields.
3. Correct any detected leaks. See a Harley-Davidson dealer.

MAINTAINING FRONT FORK

▲ WARNING

Regularly inspect shock absorbers and front forks. Replace leaking, damaged or worn parts that can adversely affect stability and handling, which could result in death or serious injury. (00012a)

Have a Harley-Davidson dealer drain the front fork oil and refill at proper intervals.

Rebound action of the fork will be impaired if the fork oil level is low.

If fork does not appear to be working properly or a significant oil leak should develop, see a Harley-Davidson dealer.

Refer to SERVICE INTERVALS AND RECORDS > SERVICE RECORDS (Page 253) for all maintenance schedules.

ADJUSTING STEERING HEAD BEARINGS

⚠ WARNING

Adjustments to steering head bearings should be performed by a Harley-Davidson dealer. Improperly adjusted bearings can adversely affect handling and stability, which could result in death or serious injury. (00051b)

Refer to SERVICE INTERVALS AND RECORDS > SERVICE RECORDS (Page 253) for all maintenance schedules.

See a Harley-Davidson dealer to adjust the steering head bearings.

SHOCK ABSORBERS

Inspect shock absorbers, preload adjuster/hydraulic hose and rubber bushings for leaks and bushing deterioration at proper intervals.

⚠ WARNING

Shock absorber cannot be serviced. Attempting service can cause an explosion, which could result in death or serious injury. (00602d)

- Do not refill, disassemble, puncture or expose shock to flames.
- Replacement and disposal should only be done by an authorized Harley-Davidson dealer.

INSPECTING AIR FILTER

Removal

1. See Figure 102. Remove two cover screws (1) and remove cover (2).
2. Remove air filter screws (3) and remove air filter element (4).

Cleaning Filter Element

⚠ WARNING

Do not use gasoline or solvents to clean filter element. Flammable cleaning agents can cause an intake system fire, which could result in death or serious injury. (00101a)

▲ WARNING

Compressed air can pierce the skin and flying debris from compressed air could cause serious eye injury. Wear safety glasses when working with compressed air. Never use your hand to check for air leaks or to determine air flow rates. (00061a)

NOTE

Do not strike filter element on a hard surface to dislodge dirt.

1. Wash the paper/wire mesh filter element in lukewarm water and mild detergent.

NOTE

Do NOT use air cleaner filter oil on the Harley-Davidson air filter element.

2. Allow filter element to air dry or use low-pressure compressed air from the inside of the filter.

NOTE

The element is sufficiently clean when light is uniformly visible through the media.

3. Hold the filter element up to a strong light to check progress.

4. Replace the filter element if the element cannot be adequately cleaned or if the element is damaged.

Installation

1. See Figure 102. Apply Loctite 243 MEDIUM STRENGTH THREADLOCKER AND SEALANT (BLUE) to threads of air filter screws (3).

2. Install air filter element (4).

3. Install air filter screws. Tighten.

Torque: 78–86 **in-lbs** (8.8–9.7 N·m) *Air filter element screws*

4. Install air cleaner cover.

5. Install cover screws (1). Tighten.

Torque: 29–32 **in-lbs** (3.3–3.6 N·m) *Air filter cover screws*

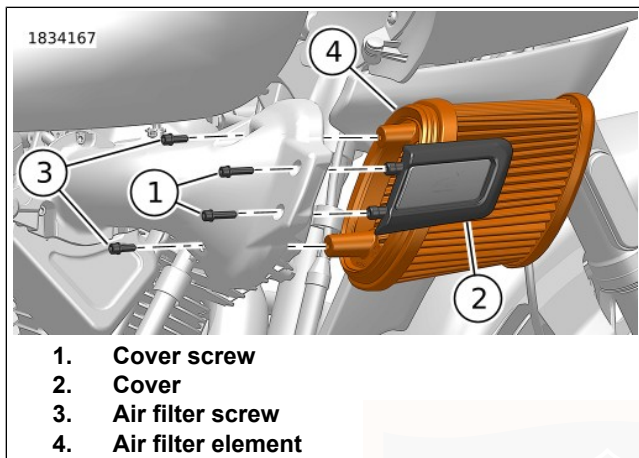

Figure 102. Air Filter Element

INSPECTING BREATHER HOSE

1. See Figure 103. Pull breather hose (1) straight up off barbed fitting (2) on top of transmission.
2. Inspect inside of hose and barbed fitting. Remove any build up found.
3. Install hose on barbed fitting.

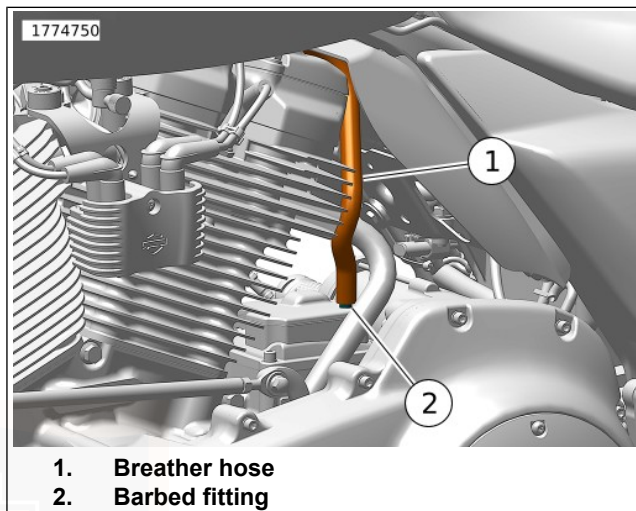

Figure 103. Breather Hose

REPLACING SPARK PLUGS

⚠ WARNING

Disconnecting spark plug cable with engine running can result in electric shock and death or serious injury. (00464b)

▲ CAUTION

Do NOT pull on any electrical wires. Pulling on electrical wires may damage the internal conductor causing high resistance, which may result in minor or moderate injury. (00168a)

NOTE

Fuel tank removal improves access to the center spark plug. Refer to the service manual or see a Harley-Davidson dealer for service.

Check the spark plugs at proper intervals. Refer to SERVICE INTERVALS AND RECORDS > SERVICE RECORDS (Page 253).

1. Disconnect spark plug cables from plugs by pulling up on the molded connector caps.
2. Check spark plug type. Only use spark plugs specified for your model motorcycle.
3. Check spark plug gap against specifications. Refer to Table 15.
4. Always tighten to the proper torque. Spark plugs must be tightened to the torque specified for proper heat transfer. Refer to Table 15.
5. Connect each molded connector cap until the cap snaps firmly into place over the spark plug.

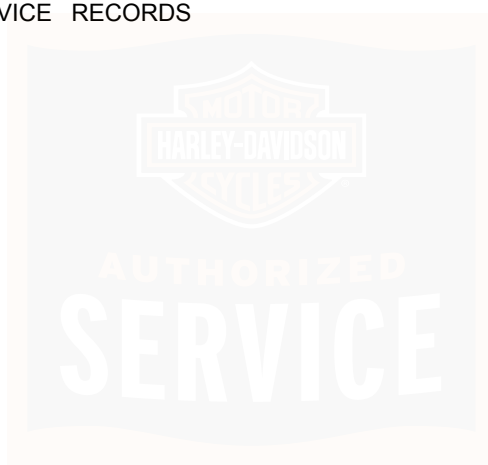

SIDE COVERS

See Figure 104. Remove side covers to access fuses and other components.

Remove: Remove saddlebag. Pull side cover off.

Install: Align barbed studs on side cover with grommets in frame. Push in to secure cover.

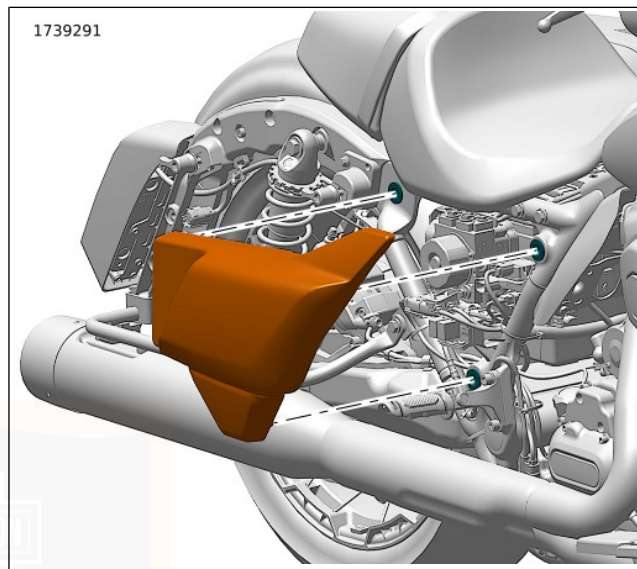

Figure 104. Side Cover

BATTERY TENDER CONNECTOR

NOTE

The main fuse and P&A fuse must both be installed to use a battery tender.

See Figure 105. The motorcycle has a quick disconnect battery tender connector under the left side cover below the main fuse. Connecting a battery tender between rides and during storage can maintain battery charge and extend the life of the battery.

To access connector, remove left side cover. See SERVICE PROCEDURES > SIDE COVERS (Page 207).

Route the connector through the slot in the bottom of the electrical caddy. Secure the harness and connector with cable straps in a location that prevents damage to the connector and surrounding areas. Make sure to apply ELECTRICAL CONTACT LUBRICANT to the terminals. Keep the connector capped to prevent moisture damage when not in use.

See Figure 106. Connect an automatic, constant monitoring battery charger/tender as shown. The connector is compatible with all Harley-Davidson battery tenders.

For more charging information, see SERVICE PROCEDURES > BATTERY MAINTENANCE (Page 209).

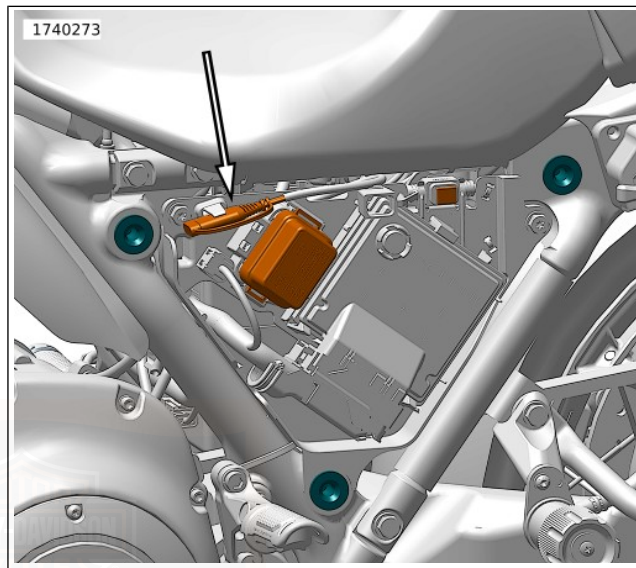

Figure 105. Battery Tender Connector (under left side cover)

1124209

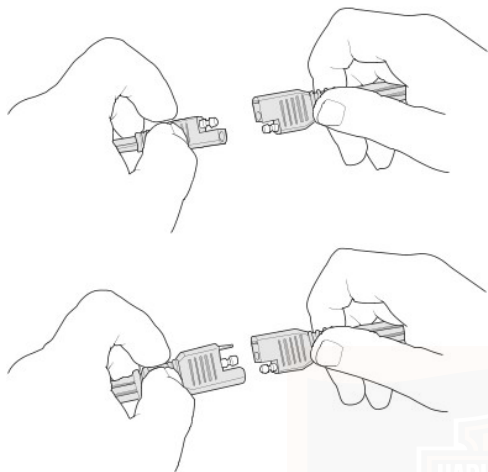

Figure 106. Battery Tender Connection

BATTERY MAINTENANCE

Battery Safety

⚠ WARNING

Batteries contain sulfuric acid, which could cause severe burns to eyes and skin. Wear a protective face shield, rubberized gloves and protective clothing when working with batteries. **KEEP BATTERIES AWAY FROM CHILDREN.** (00063a)

⚠ WARNING

Explosive hydrogen gas, which escapes during charging, could cause death or serious injury. Charge battery in a well-ventilated area. Keep open flames, electrical sparks and smoking materials away from battery at all times. **KEEP BATTERIES AWAY FROM CHILDREN.** (00065a)

⚠ WARNING

Batteries, battery posts, terminals and related accessories contain lead and lead compounds, and other chemicals known to the State of California to cause cancer, and birth defects or other reproductive harm. Wash hands after handling. (00019e)

▲ WARNING

Never remove warning label from battery. Failure to read and understand all precautions contained in warning, could result in death or serious injury. (00064b)

Absorbed Glass Mat (AGM) Battery Charging Information

The motorcycle has a permanently sealed, maintenance-free Absorbed Glass Mat (AGM) battery design that is superior to conventional flooded lead acid batteries. This battery design will provide many years of dependable service when the proper battery charging equipment and storage procedures are used. Because of the sealed, nonspillable battery design, an automatic, constant monitoring battery charger/tender with a charging rate of 5 amps or less at less than 14.6 volts is recommended to prevent overcharging conditions that will dry out the cells of the battery. Constant current battery chargers (including trickle chargers) are not recommended and can damage AGM batteries. Do not attempt to open the battery for any reason.

A Harley-Davidson constant monitoring battery charger or tender is recommended to maintain a full charge between rides or when your motorcycle will not be ridden for more than two weeks. The best practice is installing the charger/tender any time the motorcycle is not in use. Harley-Davidson offers a variety of fully automatic charger/tenders (North American

and international versions available). These battery charger/tenders include a quick disconnect cable, allowing easy connection to charge the battery without disassembly of the motorcycle.

Lack of regular battery charging or use of constant current battery chargers may void battery warranty.

Cleaning and Inspecting

Battery top must be clean and dry. Dirt and electrolyte on top of the battery can cause battery to self-discharge.

1. Clean top of battery.
2. Clean cable connectors and battery terminals using a wire brush or fine grit sandpaper to remove any oxidation.
3. Inspect and clean the battery screws, clamps and cables. Check for breakage, loose connections and corrosion.
4. Check the battery posts for melting or damage caused by over-tightening.
5. Inspect the battery for discoloration, a raised top or a warped or distorted case. Any of these conditions indicate that the battery has been frozen, overheated or overcharged.
6. Inspect the battery case for cracks or leaks.

Charging and Storing the Battery

A battery that is left in the motorcycle can either self-discharge or discharge from parasitic loads. Parasitic loads occur from things like diode leakage and maintaining computer memory. A battery that is removed from the motorcycle can also self-discharge. It is not necessary to remove battery from vehicle for storage.

- Batteries self-discharge at a faster rate at higher ambient temperatures.
- To reduce the self-discharge rate, store battery in a cool, dry place.

An automatic, constant monitoring battery charger/tender with a charging rate of 5 amps or less at less than 14.6 volts is recommended. The use of constant current chargers (including trickle chargers) to charge sealed AGM batteries is not recommended. Any overcharge will cause dry-out and premature battery failure. Never charge a battery without first reviewing the instructions for the charger being used. In addition to the manufacturer's instructions, follow the general safety precautions.

Charge the battery when:

- Motorcycle lights appear dim.
- Electric starter sounds weak.
- Battery has not been used for two weeks or more.

▲ WARNING

Unplug or turn OFF battery charger before connecting charger cables to battery. Connecting cables with charger ON can cause a spark and battery explosion, which could result in death or serious injury. (00066a)

NOTE

Make sure that the ignition and all electrical accessories are turned off.

Always follow charging instructions supplied with the charger/tender.

1. With battery in the motorcycle.
 - a. Connect battery charger/tender lead to motorcycle battery tender connector. See SERVICE PROCEDURES > BATTERY TENDER CONNECTOR (Page 207).
 - b. When charging is completed turn OFF the charger. Disconnect the motorcycle battery tender connector.
2. With battery removed from motorcycle.
 - a. Place the battery on a level surface.

- b. Connect battery charger/tender lead to battery connector adapter lead supplied with the battery charger/tender.

NOTICE

Do not reverse the charger connections described in the following steps or the charging system of the motorcycle could be damaged. (00214a)

- c. Connect the red battery charger lead to the positive terminal of the battery.
- d. Connect the black battery charger lead to the negative terminal of the battery.
- e. Step away from the battery and turn on the charger.

⚠ WARNING

Unplug or turn OFF battery charger before disconnecting charger cables from battery. Disconnecting clamps with charger ON can cause a spark and battery explosion, which could result in death or serious injury. (00067a)

- f. When charging is completed turn OFF the charger. Disconnect the black battery charger lead. Disconnect the red battery charger lead.

BATTERY REPLACEMENT

Disconnection and Removal

1. Remove seat.
2. In order to prevent damage to electrical components, use the following procedure to deactivate the electrical system before disconnecting power.
 - a. Verify hands-free fob is present.
 - b. Turn ignition switch ON.
 - c. Remove left side cover.
 - d. See Figure 111. Remove main fuse (2).
3. See Figure 107. Disconnect rear lighting harness connector (4).
4. Remove heated gear connectors (2) from top caddy (1).
5. Push latch (5) rearward slightly and lift front of top caddy. Slide top caddy forward to release it from BCM caddy tab (3).

6. Lift top caddy up and move it out of the way. It is not necessary to disconnect remaining connectors attached to top caddy.
7. See Figure 108. Push latch (3) forward slightly and lift front of BCM (1). Slide BCM forward to release it from BCM caddy tabs (2).
8. Lift BCM up and move it out of the way. It is not necessary to disconnect BCM connectors.
9. See Figure 109. Remove screw (3) and BCM caddy (1).

⚠ WARNING

Disconnect negative (-) battery cable first. If positive (+) cable should contact ground with negative (-) cable connected, the resulting sparks can cause a battery explosion, which could result in death or serious injury. (00049a)

10. See Figure 110. Disconnect both battery terminal screws (2, 3), negative battery terminal first.
11. Pull up battery lifting strap (1) to raise battery. When battery is extracted far enough to get a good grip, grasp battery and remove completely.

Installation and Connection

1. Turn ignition switch OFF.
2. Run battery strap rearward across the bottom of the battery tray, then up and across the frame crossmember.
3. See Figure 110. Place the battery into the battery tray, terminal side forward.

⚠ WARNING

Connect positive (+) battery cable first. If positive (+) cable should contact ground with negative (-) cable connected, the resulting sparks can cause a battery explosion, which could result in death or serious injury. (00068a)

NOTICE

Connect the cables to the correct battery terminals. Failure to do so could result in damage to the motorcycle electrical system. (00215a)

NOTICE

Do not over-tighten bolts on battery terminals. Use recommended torque values. Over-tightening battery terminal bolts could result in damage to battery terminals. (00216a)

4. Connect both battery cables, positive battery cable first. Tighten.
Torque: 60.2–69.9 **in-lbs** (6.8–7.9 N·m) *Battery terminal bolt*

NOTICE

Keep battery clean and lightly coat terminals with petroleum jelly to prevent corrosion. Failure to do so could result in damage to battery terminals. (00217a)

5. Apply a light coat of petroleum jelly or ELECTRICAL CONTACT LUBRICANT to both battery terminals.
6. Fold battery strap forward over top of battery.
7. See Figure 109. Install BCM caddy (1). Make sure hook feature (2) hooks on top of frame tab.
8. Install screw (3). Tighten.
Torque: 26.6–35.4 **in-lbs** (3–4 N·m) *BCM caddy screw*
9. See Figure 108. Lower BCM (1) down into position on top of BCM caddy. Slide BCM rearward under rear BCM caddy tabs (2).
10. Push down front of BCM until latch (3) snaps in place.
11. See Figure 107. Lower top caddy (1) into position on top of BCM. Slide top caddy rearward under BCM caddy tab (3).
12. Push down front of top caddy until latch (5) snaps in place.
13. Install heated gear connectors (2) into retainers on top caddy.
14. Connect rear lighting harness connector (4).
15. See Figure 111. Install main fuse (2).
16. Install left side cover.
17. Install seat. Then pull up on seat to be sure it is secure.

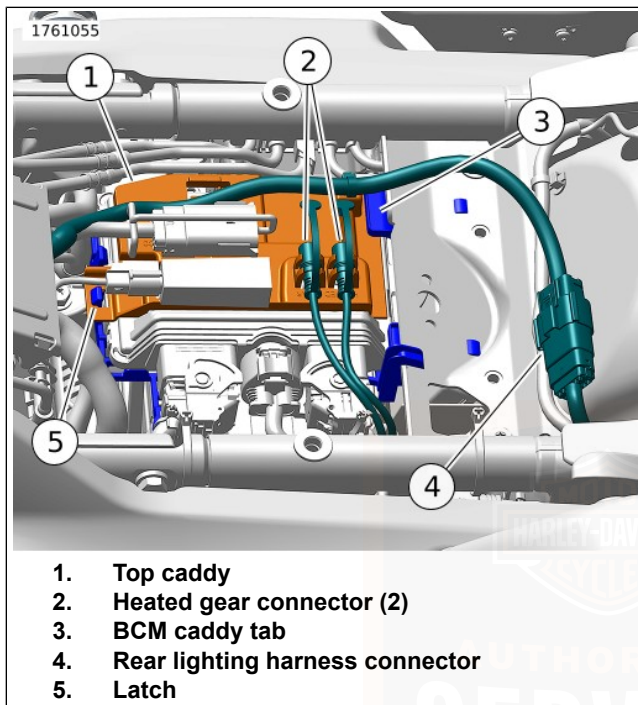

Figure 107. Removing/Installing Top Caddy

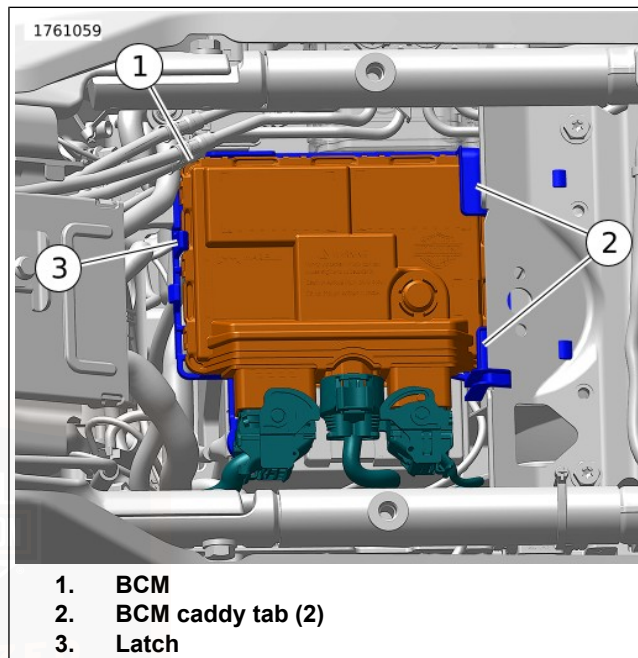

Figure 108. Removing/Installing BCM

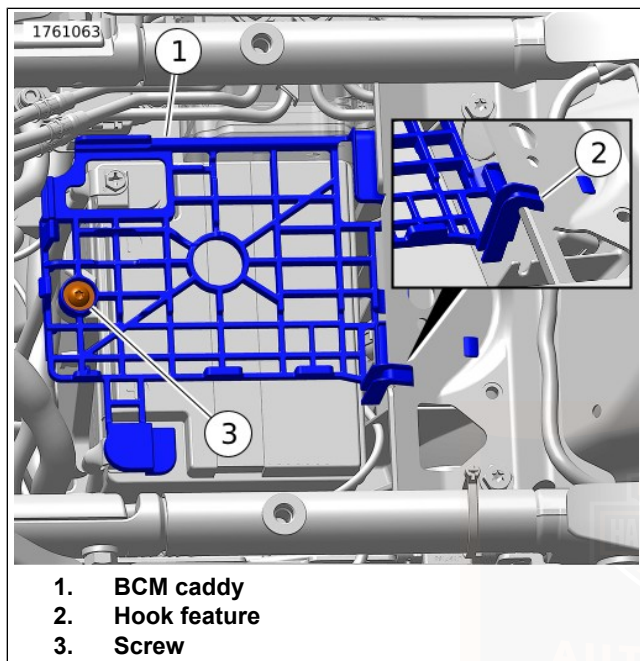

Figure 109. Removing/Installing BCM Caddy

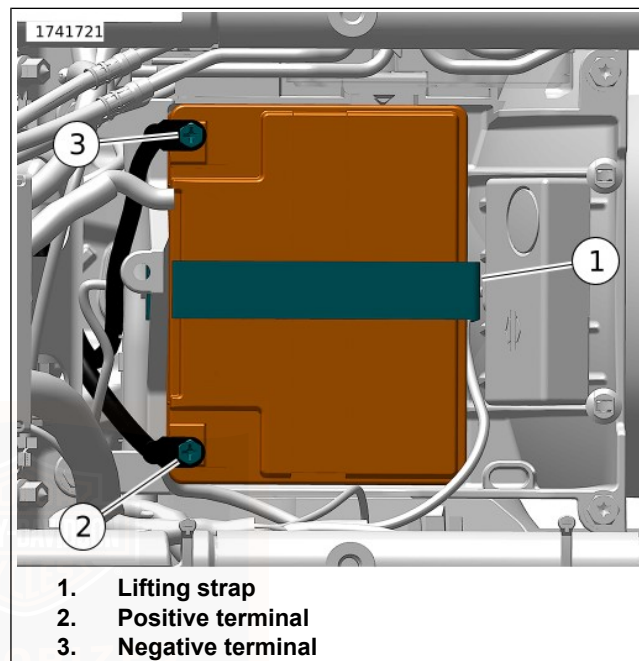

Figure 110. Battery Compartment

FUSES

Main Fuse

See Figure 111. A 60 A main fuse (2) is located near the fuse block. Removing the main fuse disconnects power to all systems except the starter motor/solenoid.

In order to prevent damage to electrical components, use the following procedure to deactivate the electrical system before disconnecting power.

1. Verify that the hands-free fob is present.
2. Push OFF/RUN/START switch to RUN position.
3. Remove the main fuse from its connector.

NOTE

Push the OFF/RUN/START switch back to OFF before installing main fuse.

System Fuses

NOTICE

Do not skip any steps for fuse replacement. Skipping fuse replacement steps can result in damage to the sound system and/or other motorcycle systems. (00223a)

See Figure 111. Fuses are located under left side cover.

If fuse replacement does not correct a problem, see a Harley-Davidson dealer for electrical diagnosis.

1. Push OFF/RUN/START switch to OFF.
2. Remove left side cover. See SERVICE PROCEDURES > SIDE COVERS (Page 207).
3. Press in tabs on the left and right sides of fuse block cover. Remove the cover.
4. See Figure 112. Remove fuse and inspect the element.

NOTICE

Always use replacement fuses that are of the correct type and amperage rating. Use of incorrect fuses can result in damage to electrical systems. (00222a)

5. Replace the fuse if the element is burned or damaged.

NOTE

Use automotive-type fuses for replacements. Spare fuses can be found in the fuse block.

6. Install the fuse block cover.

7. Install left side cover.

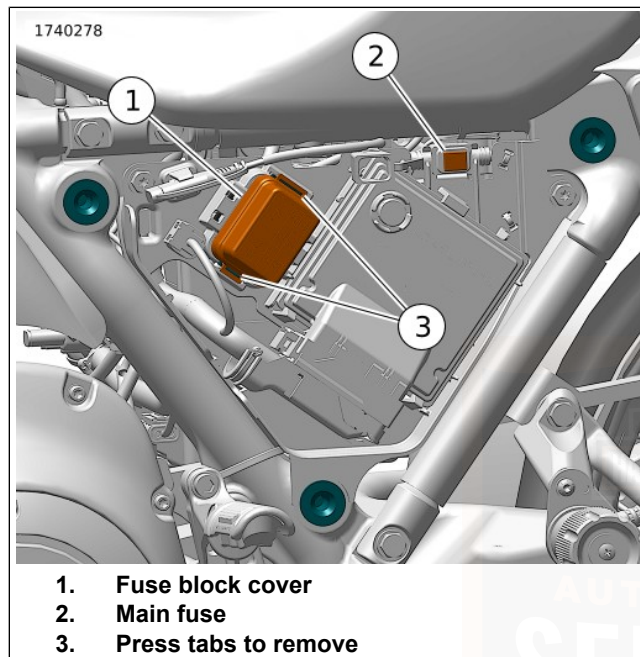

Figure 111. Fuse Block (under left side cover)

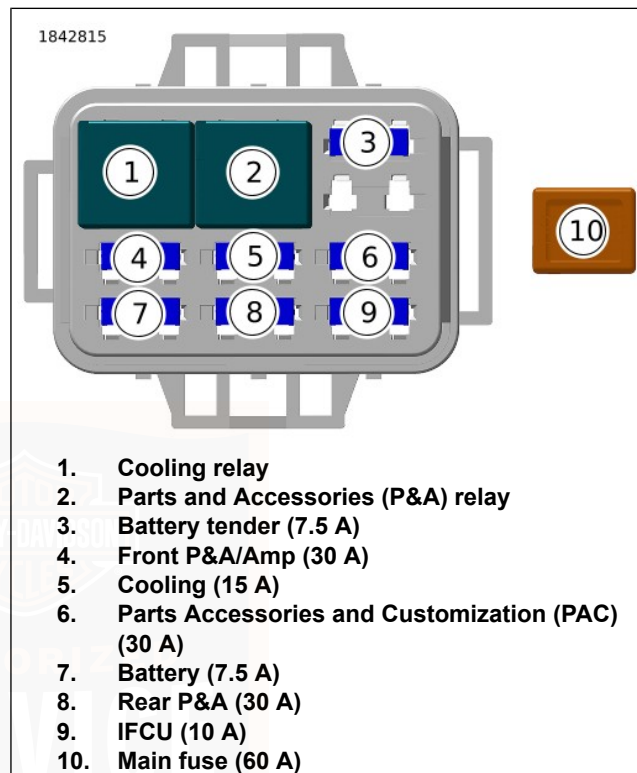

Figure 112. Fuses and Relays Identification

CHECK HEADLAMP ALIGNMENT

▲ WARNING

The automatic-on headlamp feature provides increased visibility of the rider to other motorists. Be sure headlamp is on at all times. Poor visibility of rider to other motorists can result in death or serious injury. (00030b)

1. Check tire pressure.
2. Adjust rear shocks for the rider and intended load.
3. Fill fuel tank or add an equal amount of ballast.

NOTE

Choose a wall in minimum light.

4. See Figure 113. Park the motorcycle on a line (1) perpendicular to the wall.
5. Position motorcycle so that the front of the headlamp is 16.4 ft (5 m) from the wall (3).
6. Draw a vertical centerline (6) on the wall aligned with perpendicular line (1).
7. With the motorcycle loaded, point the front wheel straight at wall. Measure the distance from the floor to the motorcycle eyebrow and subtract Distance: 1 in (25 mm) from that measurement to find low beam optical centerline (2).

8. Draw a horizontal line (5) through the vertical line on the wall, the same distance (2) from the floor as the low beam optical centerline. Draw another horizontal line (4) Distance: 1 in (25 mm) below horizontal line (5).
9. The headlamp is aligned when the top of the light beam hot spot is centered on the crossed lines (4 and 6).

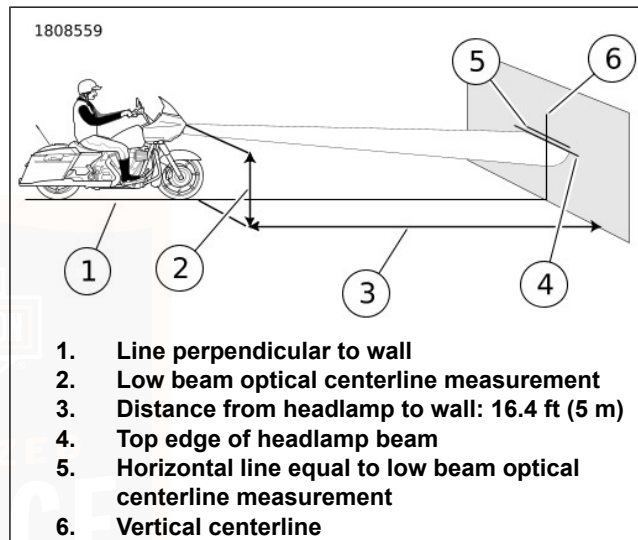

Figure 113. Headlamp Alignment

HEADLAMP ALIGNMENT

Adjust Headlamp

1. See Figure 114 and Figure 115. Insert an appropriately sized Philips #2 screwdriver vertically, behind the chin close-out panel.
2. See Figure 116. Turn the adjuster CW or CCW to adjust the light beam (3) until the top edge meets horizontal line (2).

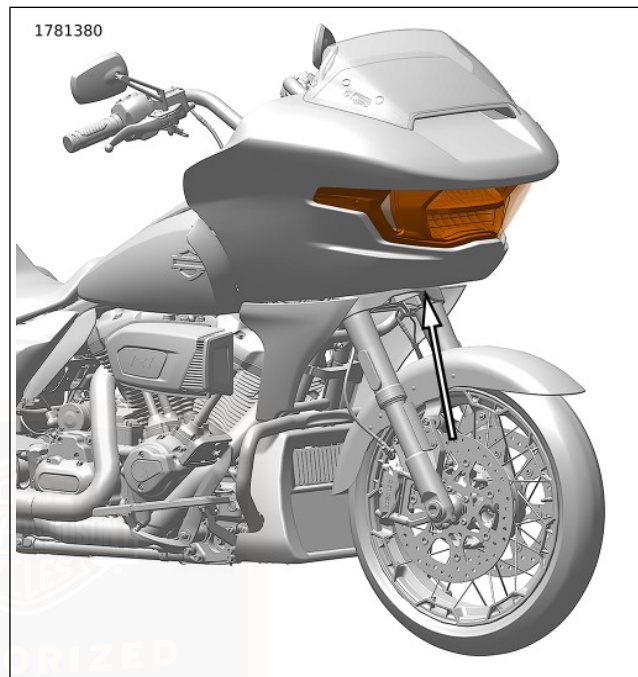

Figure 114. Headlamp Adjuster

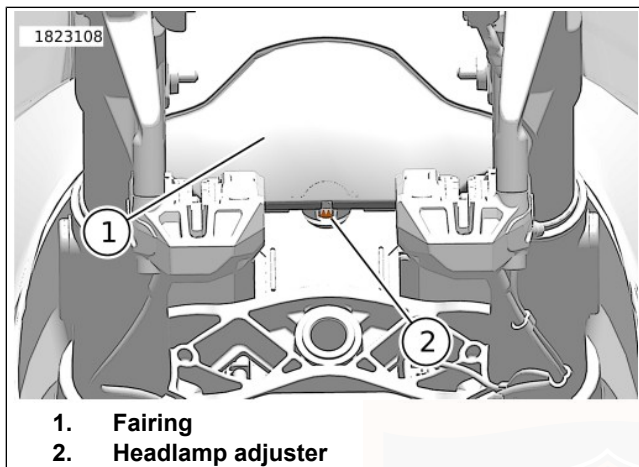

Figure 115. Headlamp Adjuster (view from under fairing)

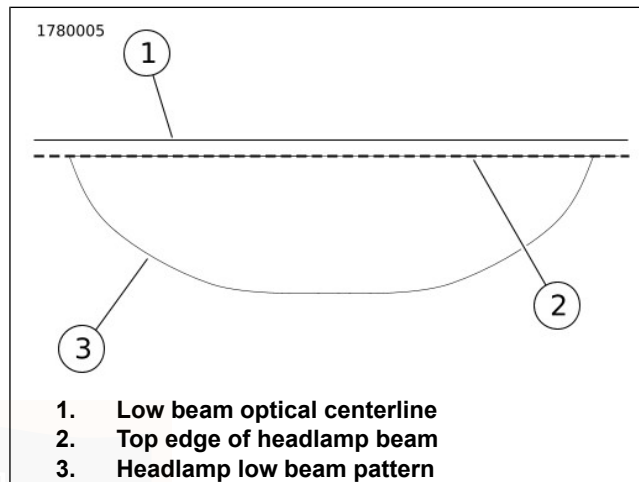

Figure 116. Alignment of Headlamp Low Beam
HEADLAMP REPLACEMENT

The headlamp is a LED headlamp and contains no replaceable bulbs. The entire assembly must be replaced upon failure. See a Harley-Davidson dealer for service.

TAIL LAMP BULB REPLACEMENT: LED

The tail lamp is a Light Emitting Diode (LED) assembly. Replace the tail lamp as a unit. See a Harley-Davidson dealer.

TURN SIGNAL BULB REPLACEMENT: LED

The LED turn signal lamp is a sealed assembly. Replace the turn signal lamp as a unit. See a Harley-Davidson dealer.

SEAT

Passenger Seat Cowl Removal

1. Remove the screw and washer from top of rear fender.
2. Slide the passenger seat cowl to the rear.

Rider Seat Removal

1. Remove the passenger seat cowl.
2. Remove the two nuts from the rear of the seat.
3. Lift rear of seat. Pull rearward to remove.

Rider Seat Installation

1. See Figure 117. Slide seat forward to engage the tongue on the frame into the slot in the seat (1). Lower the rear of the seat onto the seat mounting studs (2).
2. Install seat nuts (3). Tighten **8.0–15.0 in-lbs** (0.9–1.7 N·m)
3. Install the passenger seat cowl, if desired.
4. Pull up on the seat to be sure it is secure.

Passenger Seat Cowl Installation

1. Slide the passenger seat cowl under the rear of rider seat cushion and engage the bracket fork with the slots in the seat mounting nuts.
2. Install screw with washer to secure passenger seat cowl to rear fender (5). Tighten. **8.0–15.0 in-lbs** (0.9–1.7 N·m)
3. Pull up on the passenger seat cowl to be sure it is secure.

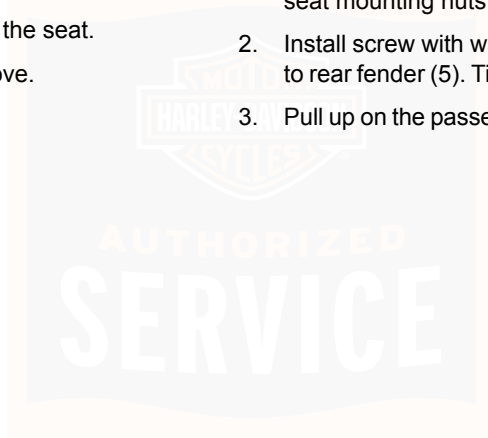

1834850

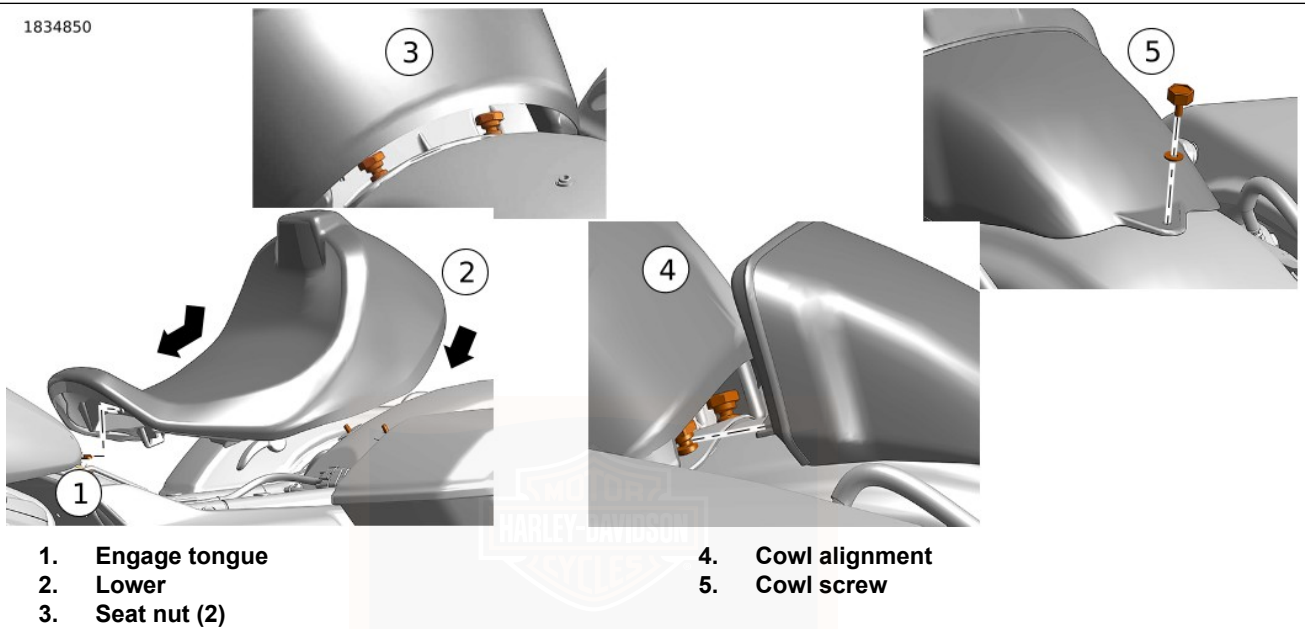

Figure 117. Seat and Cowl

SERVICE

NOTES



TROUBLESHOOTING: GENERAL

⚠ WARNING

The troubleshooting section of the Owner's Manual is a guide to diagnose problems. Read the service manual before performing any work. Improper repair and/or maintenance could result in death or serious injury. (00080a)

Use the following checklists for troubleshooting. Carefully check each cause because more than one condition can cause trouble.

ENGINE

Starter Does Not Operate or Does Not Turn Engine Over

1. Engine run switch in OFF position.
2. Discharged battery or loose or corroded connections (solenoid chatters).
3. Clutch lever not squeezed against handlebar or transmission not in neutral.
4. Jiffy stand not in retracted position.
5. Blown fuse.

Engine Turns Over but Does Not Start

1. Fuel tank empty.
2. Discharged battery or loose or damaged battery terminal connections.
3. Fouled spark plugs.
4. Spark plug cable connections loose or in bad condition and shorting.
5. Loose or corroded wire or cable connection(s) at coil or battery.
6. Fuel pump inoperative.
7. Blown fuse.

Starts Hard

1. Automatic Compression Release (ACR) not functioning properly.
2. Spark plugs in bad condition, have improper gap, or are partially fouled.
3. Spark plug cables in bad condition and leaking.
4. Battery nearly discharged.
5. Loose wire or cable connection(s) at one of the battery terminals or at coil.
6. Engine oil too heavy (winter operation).

7. Fuel tank vent plugged or fuel line closed off, restricting fuel flow.
8. Water or dirt in fuel system.
9. Fuel pump inoperative.

Starts but Runs Irregularly or Misses

1. Spark plugs in bad condition or partially fouled.
2. Spark plug cables in bad condition and leaking.
3. Spark plug gap too close or too wide.
4. Battery nearly discharged.
5. Damaged wire or loose connection at battery terminals or coils.
6. Intermittent short circuit due to damaged wire insulation.
7. Water or dirt in fuel system or filter.
8. Fuel vent system plugged. See dealer.
9. One or more injectors fouled.

A Spark Plug Fouls Repeatedly

1. Incorrect spark plug.

Pre-Ignition or Detonation (Knocks or Pings)

1. Incorrect fuel.

2. Incorrect spark plug for the kind of service.

Overheats

1. Insufficient oil supply or oil not circulating.
2. Heavy carbon deposit from lugging engine. See dealer.
3. Insufficient air flow over cylinder heads during extended periods of idling or parade duty.

Excessive Vibration

1. Rear fork pivot shaft nuts loose. See dealer.
2. Front engine mounting bolts loose. See dealer.
3. Engine to transmission mounting bolts loose. See dealer.
4. Damaged frame. See dealer.
5. Front chain or links tight as a result of insufficient lubrication or belt badly worn.
6. Wheels and/or tires damaged. See dealer.
7. Vehicle not properly aligned. See dealer.

Engine Oil Not Circulating (Oil Pressure Lamp Lit)

1. Insufficient or diluted oil supply.
2. Oil feed clogged with ice and sludge in freezing weather.

3. Grounded oil signal switch wire or faulty signal switch. See dealer.
4. Damaged or improperly installed check valve. See dealer.
5. Oil pump problem. See dealer.

ELECTRICAL SYSTEM

Alternator Does Not Charge

1. Regulator not grounded. See dealer.
2. Engine ground wire loose or damaged. See dealer.
3. Loose or damaged wires in charging circuit. See dealer.

Alternator Charge Rate is Below Normal

1. Weak battery.
2. Excessive use of add-on accessories.
3. Loose or corroded connections.
4. Extensive periods of idling or low speed riding.

TRANSMISSION

Transmission Shifts Hard

1. Clutch controls improperly adjusted. See dealer.
2. Bent shifter rod. See dealer.

Transmission Jumps Out of Gear

1. Worn shifter dogs in transmission. See dealer.

Clutch Slips

1. Clutch controls improperly adjusted. See dealer.
2. Worn friction discs. See dealer.
3. Insufficient clutch spring tension. See dealer.

Clutch Drags or Does Not Release

1. Clutch controls improperly adjusted. See dealer.
2. Primary chaincase overfilled.
3. Clutch discs warped. See dealer.

Clutch Chatters

1. Friction discs or steel discs worn or warped. See dealer.

BRAKES

ABS System Behavior

1. ABS lamp does not shut off above 3 mph (5 km/h). See dealer.
2. Other ABS symptoms. Refer to Table 31.

Brakes Do Not Hold Normally

1. Master cylinder low on fluid. See dealer.
2. Brake line contains air bubbles. See dealer.
3. Master cylinder or caliper piston worn. See dealer.
4. Brake pads contaminated with grease or oil. See dealer.
5. Brake pads badly worn. See dealer.
6. Brake disc badly worn or warped. See dealer.
7. Brake fades because of heat build up. Excessive braking or brake pads dragging. See dealer.
8. Brake drags. Insufficient hand lever free play. See dealer.

HANDLING

1. Improperly loaded motorcycle. Non-standard equipment such as heavy radio receivers, extra lighting equipment excess or unsecured luggage may cause unstable handling.
2. Load (rider, passenger and gear) exceeds maximum GVWR.
3. Damaged tires or improper front-rear tire combination. See dealer.

4. Incorrect, non-specified tire mounted on front or rear wheel. See dealer.
5. Incorrect tire pressure.
6. Irregular or peaked front tire tread wear. See dealer.
7. Tire and wheel unbalanced. See dealer.
8. Shock absorber not functioning normally. See dealer.
9. Incorrect suspension adjustment.
10. Loose wheel axle nuts. Tighten to recommended torque specification. See dealer.
11. Excessive wheel bearing play. See dealer.
12. Swing-back (steering head bearing adjustment) out-of-specification. Adjust and replace pitted or worn bearings and races. See dealer.
13. Rear fork pivot assembly improperly tightened or assembled, or loose/pitted or damaged pivot bearings. See dealer.
14. Engine mounts and/or stabilizer links loose, worn or damaged. See dealer.

MAINTENANCE RESPONSIBILITIES

This owner's manual contains your owner's maintenance record.

It is your responsibility as the owner to follow the maintenance schedule at the mileage intervals as specified in the owner's manual.

1. Make an appointment with a Harley-Davidson dealer for inspection and service prior to the first 1,000 mi (1,600 km), and as soon as possible after any issue arises.
2. Bring this owner's manual with you when you visit your authorized Harley-Davidson dealer to have your motorcycle inspected and serviced.
3. Have the dealer technician sign the maintenance record in the owner's manual at the proper mileage interval. These records should be retained by the owner as proof of proper maintenance.
4. Keep receipts covering any parts, service or maintenance performed.

These records should be transferred to each subsequent owner.

While you may elect to use non genuine Harley-Davidson parts for maintenance and/or repair services, Harley-Davidson is not obligated to pay for repairs of the non genuine

Harley-Davidson parts or for repairs of any damage resulting from the use of non genuine parts.

NOTICE

It is possible to overload the vehicle's charging system by adding too many electrical accessories. If the combined electrical accessories operating at any one time consume more electrical current than the vehicle's charging system can produce, the electrical consumption can discharge the battery and cause damage to the vehicle's electrical system. (00211d)

FINDING AN AUTHORIZED DEALER

You may obtain the name and location of your nearest U.S. authorized Harley-Davidson dealer by calling 1-800-258-2464 (U.S. only). To find dealers worldwide, refer to Refer to: www.harley-davidson.com. The fact that an authorized Harley-Davidson dealership performs warranty repairs does not create an agency relationship between Harley-Davidson and the authorized dealership.

REPORTING SAFETY DEFECTS IN THE UNITED STATES

Safety defects must be reported to the National Highway Traffic Safety Administration (NHTSA) and Harley-Davidson.

NHTSA Statement

If you believe that your motorcycle has a defect which could cause a crash or could cause injury or death, you should immediately inform the National Highway Traffic Safety Administration (NHTSA) in addition to notifying Harley-Davidson.

If NHTSA receives similar complaints, it may open an investigation, and if it finds that a safety defect exists in a group of motorcycles, it may order a recall and remedy campaign. However, NHTSA cannot become involved in individual problems between you, your authorized Harley-Davidson dealer, or Harley-Davidson.

You can contact NHTSA through the following means. Additional information about motor vehicle safety is available through the website.

Telephone: Vehicle Safety Hotline (toll-free) at 1-888-327-4236 (TTY: 1-800-424-9153).

Website: www.safercar.gov

Address: Administrator, NHTSA, 400 Seventh Street SW, Washington, DC 20590

REPORTING SAFETY CONCERNS IN CANADA

Safety concerns may be reported to the Canadian Department of Transportation and Harley-Davidson.

You can contact the Canadian Department of Transportation through the following means.

Mailing Address:

Transport Canada - ASFAD

330 Sparks Street

Ottawa, ON

K1A 0N5

Telephone: 819-994-3328 (Gatineau-Ottawa area or internationally)

Toll free: 1-800-333-0510 (in Canada)

Online:

<http://www.tc.gc.ca/recalls>

REQUIRED DOCUMENTATION FOR IMPORTED MOTORCYCLES

If a Harley-Davidson motorcycle is imported into the United States, additional documentation is required for that

motorcycle to be eligible for the United States Harley-Davidson Motorcycle Limited Warranty. Refer to www.harley-davidson.com.

OWNER CONTACT INFORMATION

If you move from your present address, sell your motorcycle, or purchase a pre-owned Harley-Davidson motorcycle, see an authorized Harley-Davidson dealer to update your owner contact information.

This will provide Harley-Davidson with an accurate registration (as required by law in some countries), and will allow Harley-Davidson to notify you in the event of a recall or product program.

The rights and benefits conferred upon you and the obligations of Harley-Davidson as set forth herein are separate and distinct from any rights and duties set forth in any service contract you may have purchased from a dealership and/or third-party insurance company. Harley-Davidson does not authorize any entity to expand Harley-Davidson's warranty obligations in connection with your motorcycle or this limited warranty.

When updating your contact information, your authorized Harley-Davidson dealer will need your Vehicle Identification Number (VIN), odometer mileage, and date of vehicle transfer (if applicable).

QUESTIONS AND CONCERNS

If you have questions or concerns regarding the performance of your motorcycle or the application of the limited warranty described here, or are not satisfied with the service you are receiving from an authorized Harley-Davidson dealership, do the following:

1. Contact the selling and/or servicing dealership and speak to the sales and/or service manager.
2. If your concern cannot be addressed to your satisfaction by the dealership, contact the Harley-Davidson Customer Support Center by mailing your concern to the following address or calling the phone number below.

In the U.S., state warranty laws, often referred to as lemon laws, may provide you with certain rights not mentioned here. To the extent allowed by your state, Harley-Davidson requests that you first send written notification of any defect or warranty non-conformity that you have experienced with your motorcycle to Harley-Davidson. Harley-Davidson appreciates the opportunity to investigate your concerns and restore your satisfaction in your motorcycle by making the necessary repairs consistent with the terms of Harley-Davidson's limited warranty. Harley-Davidson requests that you send any complaints or questions to the Harley-Davidson Customer Support Center.

- Harley-Davidson Motor Company Inc. Attention: Harley-Davidson Customer Support Center P.O. Box 653 Milwaukee, Wisconsin 53201 1-800-258-2464 (U.S. only) 1-414-343-4056

Harley Davidson's limited warranty does not mean that each Harley-Davidson motorcycle is free from defects. Defects may be unintentionally introduced into motorcycles during the design and manufacturing processes and such defects could result in the need for repairs. For this reason, Harley-Davidson provides the Limited Warranty in order to remedy any such defects that result in a component malfunction or failure during the warranty period. The remedy under this written warranty, and any implied warranty, is limited to repair, replacement, or adjustment of the defective part. THIS EXCLUSIVE REMEDY SHALL NOT BE DEEMED TO HAVE FAILED ITS ESSENTIAL PURPOSE SO LONG AS HARLEY-DAVIDSON,

THROUGH ITS AUTHORIZED DEALERS, IS WILLING AND ABLE TO REPAIR, REPLACE OR ADJUST DEFECTIVE PARTS IN THE PRESCRIBED MANNER. HARLEY-DAVIDSON'S LIABILITY, IF ANY, SHALL IN NO EVENT EXCEED THE COST OF CORRECTING ANY DEFECT AS HEREIN PROVIDED AND UPON EXPIRATION OF THIS WARRANTY, ANY SUCH LIABILITY SHALL TERMINATE.

The rights and benefits conferred upon you and the obligations of Harley-Davidson as set forth in the Limited Warranty are separate and distinct from any rights and duties set forth in any service contract you may have purchased from a dealership and/or third-party insurance company. Harley-Davidson does not authorize any entity to expand Harley-Davidson's warranty obligations in connection with your motorcycle or this limited warranty.



2024 HARLEY-DAVIDSON LIMITED MOTORCYCLE WARRANTY

24 Months/Unlimited Miles

Harley-Davidson Motor Company Inc. warrants for any new 2024 Harley-Davidson[®] motorcycle that an authorized Harley-Davidson dealer will repair or replace without charge any parts found under normal use to be defective in factory materials or workmanship. Such repair or replacement of defective parts will be Harley-Davidson's sole obligation and your sole and exclusive remedy under this limited warranty. This limited warranty applies only for the duration identified below.

No person, including Harley-Davidson dealers, may modify, extend, or waive any part of this warranty. As a condition of this warranty, you are responsible for properly using, maintaining, and caring for your motorcycle as outlined in your Owner's Manual. Harley-Davidson recommends that you maintain copies of all maintenance records and receipts.

Except as described in the following paragraphs, taking your motorcycle to be serviced by a repair shop that is not an authorized Harley-Davidson dealer will not void this warranty, and using non-genuine Harley-Davidson parts alone will not void this warranty.

Harley-Davidson may, however, exclude warranty coverage for defects or damage caused by unauthorized (a) parts, (b)

service, or (c) use of the vehicle, including defects or damage caused by use of non-Genuine Harley-Davidson parts or use of the vehicle for racing or competition, and denial of coverage may be based on installation of parts designed for unauthorized uses of the vehicle, such as a trailer hitch.

Additionally, Harley-Davidson shall exclude warranty coverage and deny all warranty claims for functional defects of powertrain components for any Harley-Davidson motorcycle registered in the United States if the vehicle was tuned using a tuning product not covered by a California Air and Resources Board Executive Order or that was otherwise approved by the Environmental Protection Agency, or if Harley-Davidson or any authorized Harley-Davidson dealer has any information to show that the vehicle was tuned using a tuning product not covered by a California Air and Resources Board Executive Order or that was otherwise approved by the Environmental Protection Agency.

Disclaimers & Limitations

THERE IS NO OTHER EXPRESS WARRANTY ON THE MOTORCYCLE. ANY IMPLIED WARRANTY OF MERCHANTABILITY OR FITNESS FOR PARTICULAR PURPOSE IS LIMITED TO THE DURATION OF THE EXPRESS WARRANTY, OR TO THE DURATION SET FORTH IN YOUR STATE'S WARRANTY STATUTES, WHICHEVER IS SHORTER. ANY IMPLIED WARRANTY IS

NOT TRANSFERRED TO SUBSEQUENT PURCHASERS/BUYERS OF THE MOTORCYCLE.

THE IMPLIED WARRANTY OF FITNESS FOR A PARTICULAR PURPOSE DOES NOT APPLY IF YOUR MOTORCYCLE IS USED FOR RACING, EVEN IF THE MOTORCYCLE IS EQUIPPED FOR RACING.

Some states do not allow limitations on how long an implied warranty lasts, so the above limitation may not apply to you.

TO THE FULLEST EXTENT ALLOWED BY LAW, NEITHER HARLEY-DAVIDSON NOR ITS AUTHORIZED DEALERS SHALL BE LIABLE FOR LOSS OF TIME, INCONVENIENCE, LOSS OF MOTORCYCLE USE, COMMERCIAL LOSS OR ANY OTHER INCIDENTAL OR CONSEQUENTIAL DAMAGES.

Harley-Davidson and your dealer are not responsible for any time or income that you lose, any inconvenience, the loss of your transportation or use of your motorcycle, the cost of a rental motorcycle, fuel, travel, meals, or lodging, or for any other incidental or consequential damages you may have.

Punitive, exemplary, or multiple damages may not be recovered unless applicable law prohibits their disclaimer. You may not bring any warranty-related claim as a class representative, a private attorney general, a member of a class of claimants or in any other representative capacity. Harley-Davidson shall not be liable for any damages caused

by delay in delivery or furnishing of any products and/or services.

Some states do not allow the exclusion or limitation of incidental or consequential damages, so the above limitation or exclusion may not apply to you.

This warranty gives you specific legal rights, and you may also have other rights which vary from state to state.

Warranty Duration

1. The duration of this limited warranty is 24-months, starting from the earlier of:
 - a. The date of initial retail purchase and delivery of the motorcycle from an authorized Harley-Davidson dealer, or:
 - b. Two (2) years after the model year launch of the vehicle in question.
- **Example:** An unsold 2022 vehicle warranty will start when the 2024 models start to ship.

Your authorized Harley-Davidson dealer will submit an electronic Sales and Warranty Registration form to initiate your limited warranty.

2. Any unexpired portion of this limited warranty will be transferred to subsequent owners, upon the resale of the motorcycle during the limited warranty period.

Owner's Obligations

To obtain warranty service, return your motorcycle at your expense within the limited warranty period to an authorized Harley-Davidson dealer. The authorized Harley-Davidson dealer should be able to provide warranty service during normal business hours, depending upon the workload of the authorized dealer's service department and the availability of necessary parts.

Exclusions

For On-Road Motorcycles, this Limited warranty will not cover claims arising from the following:

1. Failure to operate or maintain your motorcycle as specified in the owner's manual, including the Maintenance Responsibilities, Service Intervals & Records, and Maintenance & Lubrication sections.
2. Abuse, neglect, misuse, improper storage, use "off the highway," or used for racing or competition of any kind.
3. Motorcycles which are not manufactured to comply with the laws of the market in which they are registered.
4. Defects or damage caused by installation of off-road parts or competition parts installed to enhance performance, or making other unapproved modifications, including but not limited to a trailer hitch. This includes the use of genuine Harley-Davidson parts in unapproved applications.
5. An act of God, war, riot, insurrection, nuclear contamination, natural disasters, including, but not limited to, lightning, forest fires, dust storms, hail storms, ice storms, earthquakes, or floods, or other circumstances out of Harley-Davidson's control.
6. A motorcycle which has been in an accident or collision, dropped or struck.
7. A Motorcycle that experiences (A) radio / TFT display syncing issues, (B) improper functioning radio / TFT display, (C) damage to the radio / TFT display caused by: including but not limited to, phone or other media storage device (MP3, jump drive, or etc.) software, abnormal use, unauthorized modification, computer viruses, or installation of unauthorized software, peripherals and attachments (accessories, GPS/Satellite units).
 - a. Replacement parts under this warranty may include a refurbished radio.

On-Road/Off-Road Vehicles

Harley-Davidson's Pan America was designed for on-road and moderate off-road use. This entails use on paved and gravel roads and groomed trails, but does not include competition courses, rally routes or similar uses.

For On-Road/Off-Road Motorcycles, this limited warranty will not cover claims arising from the following:

1. Failure to operate or maintain your motorcycle as specified in the Owner's Manual, including the Maintenance Responsibilities, Service Intervals & Records, and Maintenance & Lubrication sections.
2. Abuse, neglect, misuse, improper storage, or use for racing or competition of any kind.
3. Motorcycles not equipped to comply with the laws of the market in which they are registered.
4. Defects or damage caused by installation of off-road or competition parts installed to enhance performance, or making other unapproved modifications, including but not limited to a trailer hitch. This includes the use of genuine Harley-Davidson parts in unapproved applications.
5. An act of God, war, riot, insurrection, nuclear contamination, natural disasters, including, but not limited to, lightning, forest fires, dust storms, hail storms, ice storms, earthquakes, or floods, or other circumstances out of Harley-Davidson's control.

6. A motorcycle which has been in an accident, collision, dropped or struck.
7. A Motorcycle that experiences (A) radio / TFT display syncing issues, (B) improper functioning radio / TFT display, (C) damage to the radio / TFT display caused by: including but not limited to, phone or other media storage device (MP3, jump drive, or etc.) software, abnormal use, unauthorized modification, computer viruses, or installation of unauthorized software, peripherals and attachments (accessories, GPS/Satellite units).
 - a. Replacement parts under this warranty may include a refurbished radio.

Other Limitations

This limited warranty does not cover:

1. Parts and labor for normal maintenance as recommended in the owner's manual, or the replacement of parts due to normal wear and tear including, but not limited to, the following: light bulbs, tires, lubrication, oil and filter change, fuel system cleaning, battery maintenance, engine tune-up, spark plugs, brake pads, brake discs, clutches and components, chain/belt adjustment, and chain/belt replacement.

2. Cosmetic damage that arises as a result of owner misuse or abuse, lack of proper maintenance as described in the Owner's Manual, or environmental conditions (except concerns that result from defects in factory materials or workmanship, which are covered by this limited warranty for the duration of the limited warranty period), including but not limited to windshield cracking or other damage caused by road debris, overtightened fasteners, or use of cleaning products other than those approved by Harley-Davidson.
3. Any cosmetic damage allegedly existing at the time of retail delivery that has not been documented by the authorized Harley-Davidson selling dealer prior to retail delivery.
4. Defects or damage to the motorcycle caused by alterations outside of Harley-Davidson's factory specifications or caused by alterations or use of parts or accessories not approved for the make and model year of your motorcycle.
5. Damage caused by installation or use of non-genuine Harley-Davidson parts, or unapproved genuine Harley-Davidson parts, even those installed by an authorized Harley-Davidson dealership, that cause a genuine Harley-Davidson part to fail. Examples include, but are not limited to performance-enhancing powertrain components or software, exhaust systems, trailer hitches, non-approved tires, lowering kits, handlebars, and add-ons connected to the factory electrical system.
6. Upgraded parts as a warranty replacement. The limited warranty allows for repair or replacement of failed parts to put the vehicle, component, or part back to its original condition with factory supplied materials and as delivered. We will take all steps to repair/replace the part to make it correct for the customer. This does not include upgrades to parts - unless no other suitable component is available as a direct replacement. This would require an authorization prior to repair.

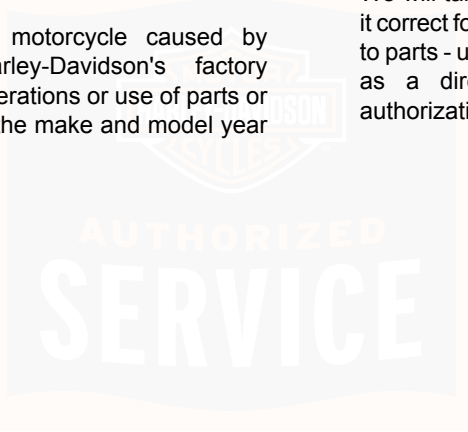

7. **United States customers:** Functional defects of powertrain components for any Harley-Davidson motorcycle registered in the United States if the vehicle was tuned using a tuning product not covered by a California Air and Resources Board Executive Order or that was otherwise approved by the Environmental Protection Agency, or if Harley-Davidson or any authorized Harley-Davidson dealer has any information to show that the vehicle was tuned using a tuning product not covered by a California Air and Resources Board Executive Order or that was otherwise approved by the Environmental Protection Agency.
2. This limited warranty is a contract between you and Harley-Davidson. It is separate and apart from any warranty, service plan, or service contract you may receive or purchase from an authorized Harley-Davidson dealer. An authorized Harley-Davidson dealer is not authorized to alter, modify, expand, or in any way change the terms and conditions of this limited warranty.
3. Any warranty work or parts replacement authorized by Harley-Davidson will not preclude Harley-Davidson from later relying on any exclusion where applicable.

Important: Read Carefully

1. Authorized Harley-Davidson dealers are independently owned and operated and may sell non-Harley-Davidson products. Because of this, HARLEY-DAVIDSON IS NOT RESPONSIBLE FOR THE SAFETY, QUALITY, OR SUITABILITY OF ANY NON-HARLEY-DAVIDSON PART, ACCESSORY OR DESIGN MODIFICATION INCLUDING, BUT NOT LIMITED TO, LABOR WHICH MAY BE SOLD AND/OR INSTALLED BY AUTHORIZED HARLEY-DAVIDSON DEALERS.

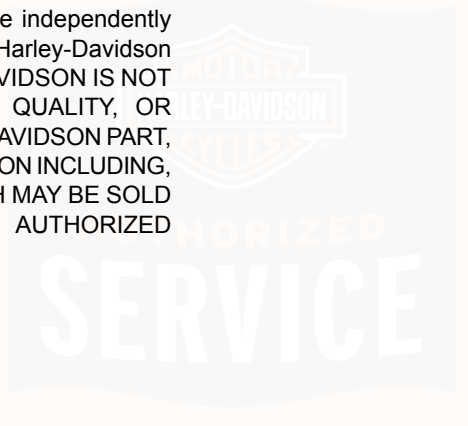

4. Harley-Davidson and its authorized dealers reserve the right to modify or service motorcycles designed and manufactured by Harley-Davidson at any time without incurring any additional obligation to make the same alteration or change to a motorcycle previously built and sold. Harley-Davidson reserves the right to provide post-warranty repairs, conduct repair campaigns, offer good-will or customer satisfaction repairs or extend the warranty coverage for certain motorcycles at its sole discretion. Said repairs or extensions of warranty coverage in no way obligates Harley-Davidson to provide similar accommodations to other owners of similar motorcycles. Sometimes Harley-Davidson may offer a special adjustment program to pay all or part of the cost of certain repairs beyond the terms of your limited warranty. Check with your authorized Harley-Davidson dealer to learn whether such programs are available to you. Your state may prohibit these types of offers, in which case, they may not be available to you.
5. The fact that a part is labeled or branded Harley-Davidson does not necessarily make it appropriate or warranted for the make and model of your motorcycle. The use of parts not designed and tested for your motorcycle may have negative consequences on the performance of your motorcycle and may cause damage or defects not covered by this limited warranty.
6. It is possible to overload your vehicle's charging system by adding too many electrical accessories. If the combined electrical accessories operating at any one time consume more electrical current than the vehicle's charging system can produce, the electrical consumption can discharge the battery and cause damage to the vehicle's electrical system.

Environmental Factors

1. Warranty will cover rust/corrosion and/or pitting on one component, one time only, under appropriate conditions. If a vehicle is exhibiting any of these conditions on more than one component, warranty coverage will be denied.
2. Warranty will cover rust/corrosion and/or pitting on multiple components only if they are the same component (i.e. both mirrors, both rider footboards, etc.)
3. Warranty will not cover rust/corrosion and/or pitting on wheels at any time unless the condition had been properly documented in the DPQA. For warrantable conditions see Cosmetic Quality Guide.
4. Warranty will not cover rust/corrosion and/or pitting as a result of damage from road debris, hazards, neglect, chemical exposure or abuse/misuse of the motorcycle.
5. Warranty will not cover rust/corrosion inside fuel tanks.
6. Warranty will not cover rust/corrosion and/or pitting or part wear that results from off-road use.

The owner is responsible for protecting the motorcycle from any cosmetic damage resulting from use and/or from exposure to the elements.

USA Owners 49 State Limited Emissions Warranty

The following limited warranty applies to the emission control system, is in addition to the MOTORCYCLE LIMITED WARRANTY and NOISE CONTROL SYSTEM LIMITED WARRANTY, and applies only to Harley-Davidson motorcycles certified for sale, registered, and normally operated in the U.S. For California models, refer to the CALIFORNIA EMISSIONS CONTROL WARRANTY STATEMENT for additional warranty provisions.

Harley-Davidson Motor Company warrants to the first owner and each subsequent owner that this vehicle is designed, built, and equipped so as to conform at the time of sale with applicable regulations under section 7521 of Title 42 of the United States Code, and that it is free from defects in materials and workmanship which would cause this motorcycle to fail to conform with applicable emissions regulations for five (5) years from the initial retail purchase and delivery from an authorized Harley-Davidson dealer (or five (5) years from the date the motorcycle is first placed in service, if it is first placed in service as a ""demonstrator"" or ""company"" motorcycle prior to delivery), or 18641 mi (30,000 km), whichever occurs first. Any unexpired portion of this limited warranty will be

transferred to subsequent owners, upon the resale of the motorcycle during the warranty period.

Harley-Davidson Motor Company Inc. warrants for any new 2024 Harley-Davidson emission control system that an authorized Harley-Davidson dealer will repair or replace without charge any parts found under normal use to be defective in factory materials or workmanship. Such repair or replacement of defective parts will be Harley-Davidson's sole obligation and your sole and exclusive remedy under this limited warranty. This limited warranty applies only for the duration identified below.

To obtain warranty service, return your motorcycle at your expense within the limited warranty period to an authorized Harley-Davidson dealer. The authorized Harley-Davidson dealer should be able to provide warranty service during normal business hours, depending upon the workload of the authorized dealer's service department and the availability of necessary parts.

For further information, you can contact Harley-Davidson Motor Company Inc. in the following ways

- By mail to: Attention: Harley-Davidson Customer Support Center P.O. Box 653 Milwaukee, Wisconsin 53201
- Phone: 1-800-258-2464 (U.S. only) 1-414-343-4056

THERE IS NO OTHER EXPRESS WARRANTY ON THE MOTORCYCLE. ANY IMPLIED WARRANTY OF

MERCHANTABILITY OR FITNESS FOR PARTICULAR PURPOSE IS LIMITED TO THE DURATION OF THIS WARRANTY.

Some states do not allow limitations on how long an implied warranty lasts, so the above limitation may not apply to you.

The limited warranty period shall begin on the date the motorcycle is delivered to the first retail purchaser or, if the motorcycle is placed in service as a demonstrator or company motorcycle prior to sale at retail, on the date it is first placed in service.

Except as described in the following paragraphs, taking your motorcycle to be serviced by a repair shop that is not an authorized Harley-Davidson dealer will not void this emissions control system limited warranty, and using non-genuine Harley-Davidson parts alone will not void this warranty.

Harley-Davidson may, however, exclude warranty coverage for defects or damage caused by unauthorized (a) parts, (b) service, or (c) use of the vehicle, including defects or damage caused by use of non-Genuine Harley-Davidson parts or use of the vehicle for racing or competition, and denial of coverage may be based on installation of parts designed for unauthorized uses of the vehicle, such as a trailer hitch.

Additionally, Harley-Davidson shall exclude warranty coverage and deny all warranty claims for functional defects of powertrain components for any Harley-Davidson motorcycle

registered in the United States if the vehicle was tuned using a tuning product not covered by a California Air and Resources Board Executive Order or that was otherwise approved by the Environmental Protection Agency, or if Harley-Davidson or any authorized Harley-Davidson dealer has any information to show that the vehicle was tuned using a tuning product not covered by a California Air and Resources Board Executive Order or that was otherwise approved by the Environmental Protection Agency.

THE FOLLOWING ITEMS ARE NOT COVERED BY THE EMISSION CONTROL SYSTEM LIMITED WARRANTY

1. Failures which arise as a result of misuse, tampering, alterations, accident, acts of nature, or improper or inadequate maintenance as specified in the Owner's Manual.
2. Required maintenance services (as specified in the Owner's Manual) and the replacement of parts (such as spark plugs, fuel, and oil filters, etc.) used in required maintenance.
3. Any motorcycle on which the odometer mileage has been changed so that the mileage cannot be determined.

4. TO THE FULLEST EXTENT ALLOWED BY LAW, NEITHER HARLEY-DAVIDSON NOR ITS AUTHORIZED DEALERS SHALL BE LIABLE FOR LOSS OF TIME, INCONVENIENCE, TOWING OF THE VEHICLE, LOSS OF MOTORCYCLE USE, COMMERCIAL LOSS OR OTHER INCIDENTAL OR CONSEQUENTIAL DAMAGES.

Some states do not allow the exclusion or limitation of incidental or consequential damages, so the above limitation or exclusion may not apply to you.

Items Covered by this Emission Warranty

The emission control system warranty may cover the following parts if the defect is deemed to be emissions-related:

- Air cleaner assembly, including air filter
- Camshaft
- Cam Phaser(s)
- Carbon canister
- Catalytic converter
- Crankcase breather
- Crank position sensor
- Engine Control Module
- Engine coolant temperature sensor

- Engine temperature sensor
- Fuel injectors
- Fuel pump module
- Ignition coil
- Ignition wires (Spark plug cables)
- Induction module or throttle body
- Intake air temperature sensor
- MAP sensor/TMAP sensor
- Muffler
- Purge Control Valve
- Oxygen sensors
- Spark plug
- Throttle position sensor

Fuel Tank (non-cosmetic failures only)

- Leaks
- Vapor valve
- Fuel cap

If used on the above: hoses, clamps, fittings, tubing, sealing gaskets and mounting hardware.

Detailed instructions for proper maintenance and use of this motorcycle, including the time and/or mileage intervals at which such maintenance is to be performed, may be found in this Owner's Manual under OWNER MANUAL > SERVICE INTERVALS AND RECORDS (Page 253).

Other Rights

This limited warranty gives you specific legal rights, and you may have other rights which vary from state to state.

Recommendations for Required Maintenance

It is recommended that any emission system maintenance be performed by an authorized Harley-Davidson dealer using genuine Harley-Davidson replacement parts. However, the maintenance, replacement or repair of the emissions control system may be performed by any other qualified service outlet or individual. Non-genuine Harley-Davidson parts may be used, but such parts should be checked to make sure they are certified to comply with U.S. Environmental Protection Agency Standards.

California and Select International Markets Evaporative Emission Controls

All new Harley-Davidson motorcycles sold in the State of California and select international markets have an evaporative emission control system. This system is designed

to meet CARB and local regulations in effect at the time of manufacture.

The system requires a small amount of maintenance. Periodically inspect system to verify that hoses are properly routed, not kinked or blocked and that all fittings are secure. Periodically check mounting hardware for tightness.

California Emissions Control Warranty Statement

Your Warranty Rights and Obligations

The California Air Resources Board and Harley-Davidson Motor Company are pleased to explain the emission control system warranty on your new motorcycle. In California, new motor vehicles must be designed, built, and equipped to meet the State's stringent anti-smog standards. Harley-Davidson Motor Company warrants the emission control system on your motorcycle for the periods of time listed below, provided there has been no abuse, neglect, or improper maintenance of your motorcycle.

Your emission control system may include parts such as the carburetor or fuel-injection system, the ignition system, catalytic converter, and engine computer. Also included may be hoses, belts, connectors, and other emission-related assemblies.

Where a warrantable condition exists, within the warranty period noted below, Harley-Davidson will repair your motorcycle at no cost to you including diagnosis, parts, and labor.

Manufacturer's Warranty Coverage

For a period of use of five years or 18641 mi (30,000 km), whichever first occurs, beginning on the date the motorcycle is delivered to the ultimate purchaser or, if the motorcycle is placed in service as a demonstrator or company motorcycle prior to sale at retail, the date it is first placed in service.

In accordance with Title 13 CCR 2036 (b), Harley-Davidson shall warrant to the ultimate purchaser and each subsequent purchaser during the remainder of the original warranty period that the vehicle or engine is: (1) Designed, built, and equipped so as to conform, at the time of sale, with all applicable regulations adopted by the Air Resources Board pursuant to its authority in chapters 1 and 2, part 5, division 26 of the Health and Safety Code; and (2) Free from defects in materials and workmanship which cause the failure of a warranted part to be identical in all material respects to that part as described in Harley-Davidson's application for certification.

In accordance with Title 13 CCR 2036 (d)(10), any add-on or modified part exempted by the Air Resources Board from the prohibitions of Vehicle Code section 27156 may be used on a vehicle or engine. Such use, in and of itself, shall not be grounds for disallowing a warranty claim made in accordance

with this article. Harley-Davidson shall not be liable under this article to warrant failures of warranted parts caused by the use of an add-on or modified part.

In accordance with Title 13 CCR 2036 (j)(3), except as provided in Title 13 CCR 2036 (j)(1), any adjustment of a component which as a factory installed, and properly operating, adjustment limiting device (such as an idle limiter cap) is eligible for warranty coverage under subsection Title 13 CCR 2036 (d)(10) or Title 13 CCR 2036 (j)(3).

If any emission-related part on your motorcycle is defective, the part will be repaired or replaced by Harley-Davidson Motor Company. This is your emission control system DEFECTS WARRANTY.

Owner's Warranty Responsibilities

As the motorcycle owner, you are responsible for the performance of the required maintenance listed in your Owner's Manual. Harley-Davidson recommends that you retain all receipts covering maintenance on your motorcycle, but Harley-Davidson cannot deny emissions warranty coverage solely for the lack of receipts or for your failure to ensure the performance of all scheduled maintenance, unless the condition is caused by your lack of maintenance or improper maintenance.

You are responsible for presenting your motorcycle to an authorized Harley-Davidson dealer as soon as a problem

exists. The warranty repairs should be completed in a reasonable amount of time, not to exceed 30 days.

As the motorcycle owner, you should also be aware that Harley-Davidson may deny you warranty coverage if your motorcycle or a part has failed due to abuse, neglect, improper maintenance, or unapproved modifications.

If you have any questions regarding your warranty rights and responsibilities, you should contact;

- Harley-Davidson Customer Service Department at 1-800-258-2464 (U.S. only) or 1-414-343-4056, or
- California Air Resources Board at 4001 Iowa Ave., Riverside, California 92507

Additional Warranty Terms

The emission control system of each new Harley-Davidson motorcycle was designed, built, and tested using only Genuine Harley-Davidson parts and with these parts the motorcycle is certified as being in conformity with California emission control regulations.

We recommend that you take your motorcycle to an authorized Harley-Davidson dealer for repairs under this limited warranty.

The dealer has factory-trained mechanics and genuine Harley-Davidson parts that are compliant with California emission control regulations. However, in the case of an

"emergency" (as defined below), you may have repairs performed at any available service establishment or by the owner, using any replacement part. An authorized Harley-Davidson dealer not being reasonably available, or a part not being available within a reasonable time period (not to exceed 30 days from the time the motorcycle is initially presented to a Harley-Davidson dealer for repair) constitutes an "emergency." Harley-Davidson will reimburse the owner for such repairs, including diagnosis, only if it is established that the repairs are covered under this emission warranty. Harley-Davidson's parts reimbursement, however, will not exceed our suggested retail price for all warranted parts replaced and our labor reimbursement will be limited to our recommended time allowances for emission system repairs at the geographically appropriate hourly labor rate.

To obtain reimbursement from Harley-Davidson for such emergency repairs, you must keep all failed parts and original receipts, so you can present them to an authorized Harley-Davidson dealer for inspection. Harley-Davidson recommends that you bring your motorcycle to an authorized dealer for inspection to ensure that the emergency repairs were done properly.

Remember: Use of non-Harley-Davidson replacement parts may impair the effectiveness of the emission control system or otherwise damage your motorcycle. The use of non-Harley-Davidson replacement parts does not invalidate the existing warranty, if any, on other Harley-Davidson

components unless the non-Harley-Davidson parts cause damage to warranted parts or result in the creation of an emissions non-compliant motorcycle. However, HARLEY-DAVIDSON ASSUMES NO LIABILITY UNDER THIS WARRANTY WITH RESPECT TO ANY PARTS WHICH ARE NOT GENUINE HARLEY-DAVIDSON PARTS, unless Harley-Davidson parts cause damage to non-genuine Harley-Davidson parts.

What Is Covered by this Emission Warranty

The emission control system warranty covers the following "warranted parts" only:

- Air cleaner assembly, including air filter
- Camshaft
- Cam Phaser(s)
- Carbon canister
- Catalytic converter
- Crankcase breather
- Crank position sensor
- Engine Control Module
- Engine coolant temperature sensor
- Engine temperature sensor

- Fuel injectors
- Fuel pump module
- Ignition coil
- Ignition wires (Spark plug cables)
- Induction module or throttle body
- Intake air temperature sensor
- MAP sensor/TMAP sensor
- Muffler
- Purge Control Valve
- Oxygen sensors
- Spark plug
- Throttle position sensor

Fuel Tank (non-cosmetic failures only)

- Leaks
- Vapor Valve
- Fuel cap

If used on the above: hoses, clamps, fittings, tubing, sealing gaskets and mounting hardware.

What Is Not Covered by this Emission Warranty

The emission control system warranty does not cover:

1. Malfunctions in any "warranted parts" caused by any of the following: abuse, misuse, unapproved modification or alteration, tampering, disconnection, or improper or inadequate maintenance. The warranty also does not cover replacement of listed parts in the event that the vehicle has been rendered emissions non-compliant in the state of California through actions noted above.
2. Damage resulting from accident, acts of nature or other events beyond the control of Harley-Davidson.
3. The repair or replacement of "warranted parts" which are scheduled for replacement prior to 18641 mi (30,000 km), once these parts have been replaced at the first replacement interval as part of required maintenance services.
4. Repairs and services performed by anyone other than an authorized Harley-Davidson Dealer (except in case of emergency as defined above).
5. Loss of time, inconvenience, loss of use of the motorcycle, towing of the vehicle, or commercial loss and/or consequential damages, except as otherwise required under Title 13 CCR 2036(d)(7).

6. Repairs on any motorcycle of which odometer mileage has been changed so that mileage cannot be readily determined.

TO THE FULLEST EXTENT ALLOWED BY LAW, NEITHER HARLEY-DAVIDSON NOR ITS AUTHORIZED DEALERS SHALL BE LIABLE FOR LOSS OF TIME, INCONVENIENCE, TOWING OF THE VEHICLE, LOSS OF MOTORCYCLE USE, COMMERCIAL LOSS OR OTHER INCIDENTAL OR CONSEQUENTIAL DAMAGES.

In accordance with Title 13 CCR 2036 (d)(7), Harley-Davidson shall be liable for damages to other vehicle components proximately caused by a failure under warranty of any warranted part.

Submit a warranty claim for repairs on vehicles within the 24-month factory limited warranty and mileage is less than 18641 mi (30,000 km) using an MC claim type. If the vehicle is outside 24-month factory limited warranty but within the 5-year, 18641 mi (30,000 km) emissions control system limited warranty, submit the claim on an EMS claim type.

EPA Regulations

Tampering with noise control / exhaust emissions control system prohibited:

Federal law prohibits the following acts or the causing thereof:
(1) the removal or rendering inoperative by any person other

than for the purposes of maintenance, repair, or replacement of any device or element of design incorporated into any new vehicle for the purpose of noise control prior to its sale or delivery to the ultimate purchaser or while it is in use, or (2) the use of the vehicle after such device or element of design has been removed or rendered inoperative by any person.

Among those acts presumed to constitute tampering are the following:

1. Replacing the muffler(s) and/or the entire exhaust system with parts not certified to be noise legal for street use.
2. Removing or modifying the muffler internal baffles in any way.
3. Replacing the air intake/cleaner assembly with one not certified to be noise legal for street use.
4. Modifying the air intake/cleaner assembly in such a way as to make the vehicle no longer noise legal for street use.

Noise Control System Limited Warranty

The following limited warranty applies to the noise control system, is in addition to the MOTORCYCLE LIMITED WARRANTY and EMISSION CONTROL SYSTEM LIMITED WARRANTY, and applies only to Harley-Davidson motorcycles sold in the U.S.

Harley-Davidson warrants to the first owner and each subsequent owner that this motorcycle is designed and built so as to conform at the time of sale with applicable regulations of the U.S. Environmental Protection Agency (as tested following F-76 Drive-By test procedure) and that it is free from defects in factory materials and workmanship which can cause this motorcycle not to meet U.S. Environmental Protection Agency Standards within one (1) year from initial retail purchase and delivery from an authorized Harley-Davidson dealer or one (1) year from the [second] anniversary of the last day of the model year of the motorcycle, or 3,730 mi (6,000 km) whichever occurs first. Any unexpired portion of this limited warranty will be transferred to subsequent owners, upon the resale of the motorcycle during the limited warranty period. If the motorcycle was used as a demonstrator or company motorcycle, then the limited warranty period may have started and/or expired prior to the initial retail sale. See an authorized Harley-Davidson dealer for details.

Harley-Davidson Motor Company Inc. warrants for any new 2024 Harley-Davidson noise control system that an authorized Harley-Davidson dealer will repair or replace without charge any parts found under normal use to be defective in factory materials or workmanship. Such repair or replacement of defective parts will be Harley-Davidson's sole obligation and your sole and exclusive remedy under this limited warranty. This limited warranty applies only for the duration identified below.

To obtain warranty service, return your motorcycle at your expense within the limited warranty period to an authorized Harley-Davidson dealer. The authorized Harley-Davidson dealer should be able to provide warranty service during normal business hours, depending upon the workload of the authorized dealer's service department and the availability of necessary parts. For further information, you can contact Harley-Davidson Motor Company Inc. in the following ways

- By mail to: Attention: Harley-Davidson Customer Support Center P.O. Box 653 Milwaukee, Wisconsin 53201
- Phone: 1-800-258-2464 (U.S. only) 1-414-343-4056

Except as described in the following paragraphs, taking your motorcycle to be serviced by a repair shop that is not an authorized Harley-Davidson dealer will not void this emissions control system limited warranty, and using non-genuine Harley-Davidson parts alone will not void this warranty.

Harley-Davidson may, however, exclude warranty coverage for defects or damage caused by unauthorized (a) parts, (b) service, or (c) use of the vehicle, including defects or damage caused by use of non-Genuine Harley-Davidson parts or use of the vehicle for racing or competition, and denial of coverage may be based on installation of parts designed for unauthorized uses of the vehicle, such as a trailer hitch.

Additionally, Harley-Davidson shall exclude warranty coverage and deny all warranty claims for functional defects of

powertrain components for any Harley-Davidson motorcycle registered in the United States if the vehicle was tuned using a tuning product not covered by a California Air and Resources Board Executive Order or that was otherwise approved by the Environmental Protection Agency, or if Harley-Davidson or any authorized Harley-Davidson dealer has any information to show that the vehicle was tuned using a tuning product not covered by a California Air and Resources Board Executive Order or that was otherwise approved by the Environmental Protection Agency.

This limited warranty period shall begin on the date the motorcycle is delivered to the first retail purchaser or, if the motorcycle is placed in service as a demonstrator or company motorcycle prior to sale at retail, on the date it is first placed in service.

This warranty gives you specific legal rights, and you may also have other rights which vary from State to State.

THERE IS NO OTHER EXPRESS WARRANTY ON THE MOTORCYCLE. ANY IMPLIED WARRANTY OF MERCHANTABILITY OR FITNESS FOR PARTICULAR PURPOSE IS LIMITED TO THE DURATION OF THE EXPRESS WARRANTY, OR TO THE DURATION SET FORTH IN YOUR STATE'S WARRANTY STATUTES, WHICHEVER IS SHORTER. ANY IMPLIED WARRANTY IS NOT TRANSFERRED TO SUBSEQUENT PURCHASERS/BUYERS OF THE MOTORCYCLE. THE IMPLIED WARRANTY OF FITNESS FOR A PARTICULAR

PURPOSE DOES NOT APPLY IF YOUR MOTORCYCLE IS USED FOR RACING, EVEN IF THE MOTORCYCLE IS EQUIPPED FOR RACING. SOME STATES DO NOT ALLOW LIMITATIONS ON HOW LONG AN IMPLIED WARRANTY LASTS, SO THE ABOVE LIMITATION MAY NOT APPLY TO YOU.

The following items are not covered by the noise control system limited warranty:

1. Failures which arise as a result of misuse, alteration, or non-performance of maintenance as specified in the Owner's Manual.
2. Replacing, removing, or modifying any portion of the NOISE CONTROL SYSTEM (consisting of the exhaust system and air intake/cleaner assembly) with parts not certified to be noise legal for street use.
3. Any motorcycle on which the odometer mileage has been changed so that the mileage cannot be determined.
4. TO THE FULLEST EXTENT ALLOWED BY LAW, NEITHER HARLEY-DAVIDSON NOR ITS AUTHORIZED DEALERS SHALL BE LIABLE FOR LOSS OF TIME, INCONVENIENCE, LOSS OF MOTORCYCLE USE, COMMERCIAL LOSS OR OTHER INCIDENTAL OR CONSEQUENTIAL DAMAGES.

Some states do not allow the exclusion or limitation of incidental or consequential damages, so the above limitation or exclusion may not apply to you.

Recommendations for Required Maintenance

It is recommended that any noise system maintenance be performed by an authorized Harley-Davidson[®] dealer using Genuine Harley-Davidson[®] replacement parts. The maintenance, replacement or repair of the noise control system may be performed by any other qualified service outlet or individual. Non-genuine parts may be used only if such parts are certified to comply with applicable U.S. Environmental Protection Agency standards.

Limited Motorcycle Warranty Australia/ New Zealand Only

This Harley-Davidson Motorcycle Warranty, is provided by Harley-Davidson, Motor Company, P.O Box 653, Milwaukee, Wisconsin, 53201, U.S.A., Phone +1 (414) 343-4056, ("Harley-Davidson")

Harley-Davidson warrants for any new 2024 Harley-Davidson motorcycle that an authorized Harley-Davidson dealer will repair or replace without charge any parts found to be defective in factory materials or workmanship under normal use during the warranty period outlined above.

Such repair or replacement of parts will be Harley-Davidson's sole obligation and your sole remedy under this H-D Motorcycle Warranty, however you may have other rights under Australian and New Zealand laws, as described below.

NOTE

Goods presented for repair may be replaced by refurbished goods of the same type rather than being repaired. Refurbished parts may be used to repair goods.

Your Consumer Rights Australia/ New Zealand Only

The benefits given to you under this H-D Motorcycle Warranty are additional to, and do not detract from, other rights and

remedies that you may have in respect of the motorcycle under Australian and New Zealand laws, including consumer protection laws.

In Australia, our goods come with guarantees that cannot be excluded under the Australian Consumer Law. You are entitled to a replacement or refund for a major failure and compensation for any other reasonably foreseeable loss or damage. You are also entitled to have the goods repaired or replaced if the goods fail to be of acceptable quality and the failure does not amount to a major failure.

In New Zealand, our goods also come with guarantees that cannot be excluded under the New Zealand Consumer Guarantees Act.



NOTES



SERVICE RECORDS

Regular Service Intervals

Service must be performed at specified intervals to keep your Harley-Davidson motorcycle operating at peak performance. Refer to Service Intervals table.

Refer to Service Actions for service action definitions used in the service interval table.

NOTE

- *Whenever a vehicle is in for maintenance:*
 - a. *always check for and complete recalls and open product programs.*
 - b. *always verify that the latest calibration is installed.*
- *After completing the final service interval, repeat the service schedule starting at the 8000 km (5000 mi) interval.*

Service Intervals

Service Actions

Table 48. Service Action Definitions

ACTION	DEFINITION
Inspect	Carefully examine component for excess wear, abnormality, contact, or leaks.
Check	Verify the component is within the owner's manual or service manual service limits. Adjust or repair as necessary.
Lubricate	Lubricate the component as specified in the owner's or service manual with Harley-Davidson approved product.
Replace	Replace the component at the specified intervals.
Clean	Clean the component as specified in the owner's or service manual.
Rebuild	Rebuild the component according to the procedures in the service manual.

Maintenance Records

Maintain a record of this service to keep your new motorcycle limited warranty in force. Refer to Table 49.

Table 49. Owner's Maintenance Records

SERVICE MILE INTERVAL	DATE	DEALER NUMBER	TECHNICIAN NAME	TECHNICIAN SIGNATURE
1,000 mi (1,600 km)				
5,000 mi (8,000 km)				
10,000 mi (16,000 km)				
15,000 mi (24,000 km)				
20,000 mi (32,000 km)				
25,000 mi (40,000 km)				
30,000 mi (48,000 km)				
35,000 mi (56,000 km)				
40,000 mi (64,000 km)				
45,000 mi (72,000 km)				
50,000 mi (80,000 km)				

Table 50. Regular Service Intervals: Harley-Davidson CVO Road Glide ST FLTRXSTSE

COMPONENT	ACTION	1600 KM 1000 MI	8000 KM 5000 MI	16000 KM 10000 MI	24000 KM 15000 MI	32000 KM 20000 MI	40000 KM 25000 MI	48000 KM 30000 MI	56000 KM 35000 MI	64000 KM 40000 MI	72000 KM 45000 MI	80000 KM 50000 MI	NOTES
Service Intervals													
Electrical equipment and switches	Inspect	x	x	x	x	x	x	x	x	x	x	x	
Front tire pressure and tread	Check	x	x	x	x	x	x	x	x	x	x	x	1
Front wheel spoke tightness (if equipped)	Check	x	x			x			x			x	2, 3, 4
Front brake fluid level	Inspect	x	x	x	x	x	x	x	x	x	x	x	6

Table 50. Regular Service Intervals: Harley-Davidson CVO Road Glide ST FLTRXSTSE

COMPONENT	ACTION	1600 KM	8000 KM	16000 KM	24000 KM	32000 KM	40000 KM	48000 KM	56000 KM	64000 KM	72000 KM	80000 KM	NOTES
		1000 MI	5000 MI	10000 MI	15000 MI	20000 MI	25000 MI	30000 MI	35000 MI	40000 MI	45000 MI	50000 MI	
Clutch cable	Lubricate	x	x	x	x	x	x	x	x	x	x	x	7
Clutch cable	Adjust	x	x	x	x	x	x	x	x	x	x	x	5, 2
DOT4 front brake fluid moisture content	Check	x	x	x	x	x	x	x	x	x	x	x	1, 2
Hand control switch housing screw torque	Tighten	x		x		x		x		x		x	1, 2, 4
Clutch lever handlebar clamp screw torque	Tighten	x		x		x		x		x		x	1, 2, 4
Front brake handlebar clamp screw torque	Tighten	x		x		x		x		x		x	1, 2, 4
Steering head bearings	Lubricate						x					x	2
Air cleaner filter	Inspect		x	x	x	x	x	x	x	x	x	x	3
Engine oil and filter	Replace	x	x	x	x	x	x	x	x	x	x	x	1, 3
Primary chaincase lubricant	Replace	x		x		x		x		x		x	3
Transmission lubricant	Replace	x				x				x			3
Engine breather hose	Inspect		x	x	x	x	x	x	x	x	x	x	1, 2
Oil and brake lines	Inspect	x	x	x	x	x	x	x	x	x	x	x	1, 2, 5
Fuel lines and fittings	Inspect	x	x	x	x	x	x	x	x	x	x	x	1, 2, 5
Rear brake fluid level	Inspect	x	x	x	x	x	x	x	x	x	x	x	6
DOT4 rear brake fluid moisture content	Check	x	x	x	x	x	x	x	x	x	x	x	1, 2
Brake systems	Replace Flush brake systems and replace DOT 4 hydraulic brake fluid every two years or sooner if moisture content is 3 percent or greater.											2

Table 50. Regular Service Intervals: Harley-Davidson CVO Road Glide ST FLTRXSTSE

COMPONENT	ACTION	1600 KM 1000 MI	8000 KM 5000 MI	16000 KM 10000 MI	24000 KM 15000 MI	32000 KM 20000 MI	40000 KM 25000 MI	48000 KM 30000 MI	56000 KM 35000 MI	64000 KM 40000 MI	72000 KM 45000 MI	80000 KM 50000 MI	NOTES
Brake pads and discs	Inspect	x	x	x	x	x	x	x	x	x	x	x	
Front axle nut torque	Tighten	x		x		x		x		x		x	1, 2, 4
Jiffy stand	Lubricate	x	x	x	x	x	x	x	x	x	x	x	2, 3
Brake and clutch controls	Lubricate	x	x	x	x	x	x	x	x	x	x	x	2, 7
Rear tire pressure and tread	Check	x	x	x	x	x	x	x	x	x	x	x	1
Rear wheel spoke tightness (if equipped)	Check	x	x			x			x			x	2, 3, 4
Drive belt and sprockets	Inspect	x	x	x	x	x	x	x	x	x	x	x	2
Drive belt	Adjust	x	x	x	x	x	x	x	x	x	x	x	2
Rear sprocket isolators	Inspect	Inspect rear sprocket isolators for wear at each rear tire change.											
Rear axle nut torque	Tighten	x		x		x		x		x		x	1, 2, 4
Exhaust system, fasteners and shields	Inspect	x	x	x	x	x	x	x	x	x	x	x	1, 3
12 volt battery	Check	Check battery, terminal torque and clean connections annually. Lubricate terminals with ELECTRICAL CONTACT LUBRICANT.											1
Spark plugs	Replace	Replace spark plugs every two years or every 30,000 mi (48,000 km), whichever comes first.											
Front forks	Rebuild											x	2
Fuel filter	Replace	Replace fuel filter element every 100,00 mi (161,000 km).											2, 3
Component and system functions	Road Test	x	x	x	x	x	x	x	x	x	x	x	
NOTES													
1. Perform annually or at specified intervals, whichever comes first.													
2. Should be performed by an authorized Harley-Davidson dealer, unless you have the proper tools, service data and are mechanically qualified.													

Table 50. Regular Service Intervals: Harley-Davidson CVO Road Glide ST FLTRXSTSE

COMPONENT	ACTION	1600 KM	1000 MI	8000 KM	5000 MI	16000 KM	10000 MI	24000 KM	15000 MI	32000 KM	20000 MI	40000 KM	25000 MI	48000 KM	30000 MI	56000 KM	35000 MI	64000 KM	40000 MI	72000 KM	45000 MI	80000 KM	50000 MI	NOTES
<p>3. Perform maintenance more frequently in severe riding conditions. This includes extreme temperatures, dusty environments, mountainous or rough roads, long storage conditions, short runs, heavy stop/go traffic or poor fuel quality.</p> <p>4. For torque instructions, see Shop Practices in the service manual.</p> <p>5. Check for leaks, contact or abrasion.</p> <p>6. Brake fluid level drops as brake pads wear.</p> <p>7. Use HARLEY LUBE.</p>																								



NOTES



ACRONYMS AND ABBREVIATIONS

Table 51. Acronyms and Measurement Symbols

ITEM	DEFINITION
A	Amperes
ABS	Anti-lock braking system
AC	Alternating current
ACR	Automatic compression release
AGM	Absorbed glass mat (battery)
Ah	Ampere-hour
BCM	Body control module
°C	Celsius (Centigrade)
CCA	Cold cranking amps
CI	Cubic inch
cm	Centimeters
cm ³	Cubic centimeters (cc)
CVO	Custom vehicle operations
DC	Direct current
DLC	Data link connector
DOM	Domestic
DT II	Digital Technician II
DTC	Diagnostic trouble code
ECM	Electronic control module
EFI	Electronic fuel injection
EHCUC	Electro hydraulic control unit
EITMS	Engine idle temperature management system

Table 51. Acronyms and Measurement Symbols

ITEM	DEFINITION
ETC	Electronic throttle control
EV	Electric vehicle
EVAP	Evaporative emissions control system
EVPT	Electric vehicle powertrain
EVSE	Electric vehicle supply equipment
°F	Fahrenheit
fl oz	Fluid ounce
ft	Feet
ft-lbs	Foot pounds
FTP	Flash to pass
g	Gram
gal	Gallon
GAWR	Gross axle weight rating
GND	Ground (electrical)
GPS	Global positioning system
GVWR	Gross vehicle weight rating
H-DSSS	Harley-Davidson smart security system
HCU	Hydraulic control unit
HDI	Harley-Davidson International
HP	Horsepower
HV	High voltage
Hz	Hertz
IFCU	Infotainment control unit
IGN	Ignition light/key switch position
IM	Instrument module

Table 51. Acronyms and Measurement Symbols

ITEM	DEFINITION
IMU	Inertia measurement unit
in	inch
in ³	Cubic inch
in-lbs	Inch pounds
kg	Kilogram
km	Kilometer
km/h	Kilometers per hour
kPa	Kilopascal
kW	Kilowatt
L	Liter
lb	Pounds
LED	Light emitting diode
Li-ion	Lithium-Ion
LV	Low voltage
mA	Milliamperere
mi	Mile
MIL	Malfunction indicator lamp
Min	Minimum
mL	Milliliter
mm	Millimeter
mph	Miles per hour
ms	Millisecond
Nm	Newton-meter
OBC	Onboard charger
oz	Ounce

Table 51. Acronyms and Measurement Symbols

ITEM	DEFINITION
P&A	Parts and Accessories
PA	Public address
Part No.	Part number
PIN	Personal identification number
PPE	Personal protective equipment
psi	Pounds per square inch
PTT	Push to talk
qt	Quart
RDRS	Reflex defensive rider systems
RESS	Rechargeable energy storage system
rpm	Revolutions per minute
SDS	Safety data sheet
SoC	State of charge
SoH	State of health
SW	Software
TCS	Traction control system
TCU	Telematic Control Unit
TPMS	Tire pressure monitoring system
USB	Universal serial bus
USB-C	Universal serial bus - type C
V	Volt
VAC	Volts of alternating current
VDC	Volts of direct current
VHC	Vehicle hold control
VIN	Vehicle identification number

Table 51. Acronyms and Measurement Symbols

ITEM	DEFINITION
VR	Voice recognition
VVT	Variable valve timing
W	Watt
WSS	Wheel speed sensor
Wh	Watt-hour
WHIM	Wireless Headset Interface Module

H-D U.S.A., LLC TRADEMARK INFORMATION

Bar & Shield, Boom!, Breakout, Cruise Drive, CVO, Digital Tech, Digital Technician, Digital Technician II, Electra Glide, Evolution, Fat Bob, Fat Boy, Forty-Eight, FXDR 114, Glaze, Gloss, H-D, H-Dnet.com, Harley, Harley-Davidson, HD, Heritage Softail, Iron 1200, Iron 883, Low Rider, Milwaukee-Eight, Night Rod, Pan America, Profile, Reflex, Revolution X, Road Glide, Road King, Road Tech, Roadster, Screamin' Eagle, Seventy-Two, Slim, Softail, Sport Glide, Sportster, Street Bob, Street Glide, Street Rod, Sun Ray, Sunwash, SuperLow, Supersmart, SYN3, TechLink, TechLink II, TechLink 3, Tour-Pak, Tri Glide, Twin-Cooled, Ultra Classic, and Harley-Davidson Genuine Motor Parts and Genuine Motor Accessories are among the trademarks of H-D U.S.A., LLC.

PRODUCT REGISTERED MARKS

Android, Apple, Alcantara S.p.A., Allen, Amp Multilock, Bluetooth, Brembo, CarPlay, City Navigator, Delphi, Deutsch, Dunlop, Dynojet, Fluke, G.E. Versilube, Garmin, Gunk, Heli-Coil, Hydroseal, Hylomar, iPhone, iPod, Kevlar, Lexan, Loctite, Lubriplate, Keps, K&N, Magnaflux, Marson Thread-Setter Tool Kit, MAXI fuse, Molex, Michelin, MPZ, Multilock, nano, NGK, Novus, Packard, Pirelli, Permatex, Philips, Pozidriv, Road Tech, Robinair, S100, Sems, Siri, SiriusXM, Snap-on, Teflon, Threadlocker, Torca, Torco, TORX, Tufoil, Tyco, Ultratorch, Velcro, X-Acto and XM Satellite Radio are among the trademarks of their respective owners.

PATENTS

Harley-Davidson products are covered by one or more United States and international patents or pending patent applications.

COPYRIGHT

ALL RIGHTS RESERVED.

©2023 H-D.

NOTES



Index

A

Accessories and Cargo Guidelines.....	3
Acronyms and Abbreviations.....	259
Adjust.....	48
Adjusting Front Shock Absorbers.....	56
Adjusting Rear Shock Absorbers.....	52
Adjusting Steering Head Bearings.....	203
AGM Battery.....	209
Air Filter, Inspecting.....	203
Alarm.....	64
Anti-Lock Brake System (ABS).....	14

B

Battery.....	66,209,212
Before You Ride.....	35
Brake.....	74
Brakes.....	227
Break-in.....	36,175
Break-in Maintenance.....	175
Bulb, Replacement LED Tail Lamp.....	221
Bulb, Replacement LED Turn Signal.....	222

C

Catalytic Converter.....	39
Changing Engine Oil.....	179
Changing Transmission Lubricant.....	184
Charging.....	209
Charging Battery.....	209
Checking Engine Oil.....	177
Checklist.....	35
Clean.....	161,162,166,169,209
Cleaning.....	162,166
Clutch.....	201
Controls.....	25,74
Coolant.....	31,195
Copyright.....	261
Customer service.....	1

D

Disposal and Recycling.....	175
Drive Belt.....	198
Drive Belt Deflection Specifications.....	198

Index

E			
EITMS.....	121	Gear Shift.....	74
Electrical System.....	227	Genuine Motor Parts and Accessories.....	161
Engine.....	36,122,225	H	
Engine Idle Temperature Management System.....	121	Hand Control Modules.....	88,93
Engine OFF/RUN Switch.....	93	Hazard Warning 4-Way Flashers.....	62
Engine Oil.....	175,177,179,182	Hydraulic Lifters.....	202
Engine Oil and Filter.....	179		
F		I	
Fill.....	37	Importing a Motorcycle.....	230
Finding an Authorized Dealer.....	229	Indicators.....	82
Fob.....	59	Infotainment system.....	98
Front Fork, Maintaining.....	202	Inspect.....	209
Fuel.....	37,39	Inspecting Air Filter.....	203
Fuses.....	66,217	Inspection.....	209
Fuses and Relays.....	66	Instruments.....	77
G		J	
Gasoline.....	39	Jiffy Stand.....	49

Index

K

Key.....	59
Kick Stand.....	49

L

Labels.....	20
Leather.....	169
Leather Care.....	169
Low Beam Switch.....	88

M

Maintaining Front Fork.....	202
Maintenance.....	175, 177, 179, 184, 195, 198, 201, 202, 203, 253
Maintenance.....	229
Manual.....	1
Mirror Adjustment.....	48
Mirrors.....	48
Models and Features.....	25

N

National Highway Traffic Safety Administration.....	229
National Highway Traffic Safety Administration (NHTSA).....	229
Noise Control System.....	15

O

Oil Level.....	177
Operation.....	49, 120, 122
Owner Contact Information.....	231

P

Patents.....	261
Polishing.....	166
Power Disconnect.....	66
Pre-Ride Checklist.....	35
Primary Chaincase.....	31, 186, 186
Primary Chaincase Lubrication.....	186

R

Recommended Cleaning Products.....	162
------------------------------------	-----

Index

Registered Marks.....	261
Ride Modes.....	109
Rider Safety Enhancements.....	123
Rules of the Road.....	15

S

Safe Operating Rules.....	3
Safety.....	3,20,209
Safety Concerns Canada.....	230
Safety Symbols, Definitions.....	16
Seat.....	222
Security System.....	59,59,61,62,64, 65, 65, 65, 66, 66
Service Records.....	253
Shifting Gears.....	129
Shock Absorbers.....	203
Smart Security System.....	65,66,66
Specifications.....	31,175,198
Start Switch.....	93
Starting the Engine.....	118,120
Steering Head Bearings, Adjusting.....	203
Stopping the Engine.....	122
Storage.....	35

Storing.....	35,209
Storing.....	172
Switch.....	74,88,93

T

Tail Lamp Bulb Replacement LED.....	221
Throttle.....	74
Tire.....	161
Tires.....	161
Tires, Checking Pressure and Inspecting.....	43
Traction Control.....	127
Traction Control (TC) Description.....	127
Trademarks.....	261
Transmission.....	31,182,184,227
Transport Mode.....	65
Troubleshooting.....	66,225,227,227,227, 228
Turn Signal Bulb Replacement LED.....	222

V

Vehicle Identification Number (VIN).....	23
--	----

Index

Vehicle Storage.....35
Vinyl.....169
Vinyl Care.....169
Voltage test.....209

W

Warranty.....231
Washing.....166
Wheels.....161
Winter Lubrication.....182

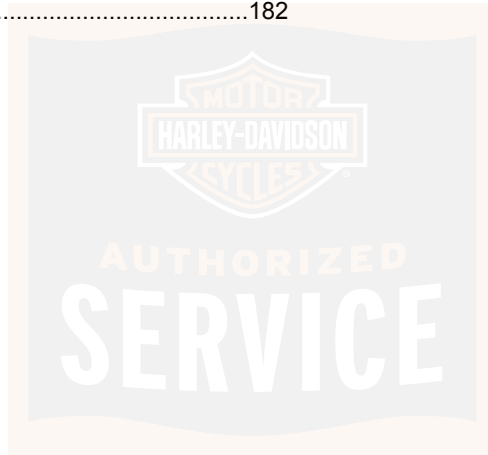

NOTES

